

IB IL AO 2/SF ...

Inline terminal with two analog outputs

AUTOMATION

Data sheet
6655_en_06

© PHOENIX CONTACT 2010-03-15

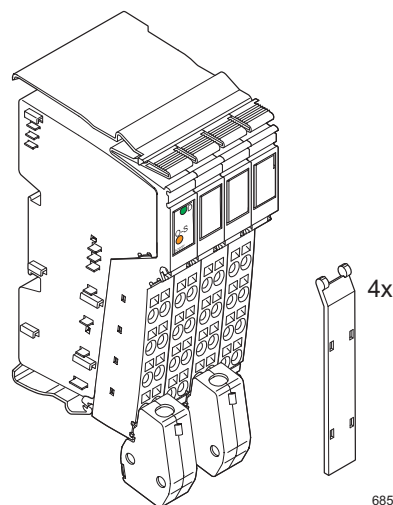

6857A002

1 Description

The terminal is designed for use within an Inline station. It is used to output analog voltage or current signals. The signals are available with a 16-bit resolution.

Features

- Two analog signal outputs to connect either voltage or current signals
- Actuator connection in 2-wire technology with shield connection
- Two current ranges, one voltage range:
0 mA to 20 mA, 4 mA to 20 mA,
0 V to 10 V
- Process data update including conversion time of the digital/analog converter <1 ms
- 16-bit resolution with high precision (voltage output 0.008%, typical, current output 0.01%, typical)
- High level of operational safety in the event of an error thanks to real 4 mA to 20 mA output
- Load range (mA outputs) 0 Ω to 500 Ω



This data sheet is only valid in association with the user manual.



Make sure you always use the latest documentation.
It can be downloaded at www.phoenixcontact.net/catalog.



This data sheet is valid for the products listed on the following page:

2 Ordering data

Products

Description	Type	Order No.	Pcs./Pkt.
Terminal with two analog outputs to output either voltage or current signals; without accessories; 500 kbps transmission speed	IB IL AO 2/SF	2862806	1
Terminal with two analog outputs to output either voltage or current signals; with accessories (connectors and labeling fields); 500 kbps transmission speed	IB IL AO 2/SF-PAC	2863083	1
Terminal with two analog outputs to output either voltage or current signals; without accessories; 2 Mbps transmission speed	IB IL AO 2/SF-2MBD	2860426	1
Terminal with two analog outputs to output either voltage or current signals; with accessories (connectors and labeling fields); 2 Mbps transmission speed	IB IL AO 2/SF-2MBD-PAC	2862194	1



You need two of the connector set listed below for the complete fitting of the IB IL AO 2/SF and IB IL AO 2/SF-2MBD terminals.

Accessories

Description	Type	Order No.	Pcs./Pkt.
Connector set	IB IL AO/CNT-PLSET	2732664	1 set

Accessories as replacement items

Description	Type	Order No.	Pcs./Pkt.
The shield connector must be used for connecting an actuator:			
Inline shield connector for analog Inline terminals, without color print	IB IL SCN-6 SHIELD	2726353	5
On slots that are not used for actuator connection you may use one of the following connectors:			
Inline shield connector for analog Inline terminals, without color print	IB IL SCN-6 SHIELD	2726353	5
Connector for digital 1, 2 or 8-channel Inline terminals, without color print	IB IL SCN-8	2726337	10
Inline connector, with color print	IB IL SCN-8-CP	2727608	10

Documentation

Description	Type	Order No.	Pcs./Pkt.
"Automation terminals of the Inline product range" user manual	IL SYS INST UM E	2698737	1
"Configuring and installing the INTERBUS Inline product range" user manual	IB IL SYS PRO UM E	2743048	1
"INTERBUS addressing" data sheet	DB GB IBS SYS ADDRESS	9000990	1

3 Technical data

General data	
Housing dimensions (width x height x depth)	48.8 mm x 120 mm x 71.5 mm
Weight	125 g (without connectors), 190 g (with connectors)
Operating mode	Process data mode with 2 words
Connection method for actuators	2-wire technology
Ambient temperatures (operation)	-25°C to +55°C
Ambient temperature (storage/transport)	-25°C to +85°C
Permissible humidity (operation/storage/transport)	10% to 95% according to DIN EN 61131-2
Permissible air pressure (operation/storage/transport)	70 kPa to 106 kPa (up to 3000 m above sea level)
Degree of protection	IP20 according to IEC 60529
Protection class	Class 3 according to EN 61131-2, IEC 61131-2
Connection data for Inline connectors	
Connection method	Spring-cage terminals
Conductor cross-section	0.2 mm ² to 1.5 mm ² (solid or stranded), 24 - 16 AWG

Deviations from common technical data that are indicated in the IB IL SYS PRO UM E user manual:**Mechanical requirements**

Shock test according to EN 60068-2-27; IEC 60068-2-27

15g load for 11 ms, half sinusoidal wave,
three shocks in each space direction and orientation
25g load for 6 ms, half sinusoidal wave,
three shocks in each space direction and orientation**Interface**

Local bus

Data routing

Transmission speed

IB IL AO 2/SF; IB IL AO 2/SF-PAC

500 kbps

IB IL AO 2/SF-2MBD; IB IL AO 2/SF-2MBD-PAC

2 Mbps

Power consumption**500 kbps****2 Mbps**Communications power U_L

7.5 V DC

7.5 V DC

Current consumption at U_L 36 mA (typical),
45 mA (maximum)60 mA (typical),
75 mA (maximum)Analog supply voltage U_{ANA}

24 V DC

24 V DC

Current consumption at U_{ANA} 75 mA (typical),
95 mA (maximum)75 mA (typical),
95 mA (maximum)

Total power consumption

2.1 W (typical)

2.3 W (typical)

Supply of the module electronics and I/O through bus coupler/power terminal

Connection method

Potential routing

Analog output

Number

2; configured depending on the terminal point used

Signals/resolution in the process data bytes (quantization) for Inline

Voltage 0 V to 10 V

0 V to 10.837 V; 0.333 mV/LSB

Current 0 mA to 20 mA

0 mA to 21.6764 mA; 0.667 μ A/LSB

4 mA to 20 mA

4 mA to 21.3397 mA; 0.533 μ A/LSB

Signals/resolution in the process data bytes (quantization) for ST

Voltage 0 V to 10 V

0 V to 9.9975 V; 2.441 mV

Current 0 mA to 20 mA

0 mA to 19.9951 mA; 4.8828 μ A

4 mA to 20 mA

4 mA to 19.9961 mA; 3.906 μ A

Basic error limit

 $\pm 0.003\%$

Output load

Voltage output

2 k Ω , minimum

Current output

0 Ω to 500 Ω

Process data update of the module including conversion time of the digital/analog converter

< 1 ms

Signal rise times: Voltage output 0 V to 10 V (typical values)

	10% to 90%	0% to > 99%
No-load operation	44 μ s	72 μ s
Ohmic load $R_L = 2 \text{ k}\Omega$	46 μ s	74 μ s
Ohmic/capacitive load $R_L = 2 \text{ k}\Omega / C_L = 10 \text{ nF}$	47 μ s	95 μ s
Ohmic/capacitive load $R_L = 2 \text{ k}\Omega / C_L = 220 \text{ nF}$	79 μ s	350 μ s
Ohmic/inductive load $R_L = 2 \text{ k}\Omega / L_L = 3.3 \text{ mH}$	48 μ s	75 μ s

Signal rise times: Current output 0 mA to 20 mA (typical values)

	10% to 90%	0% to > 99%
Ohmic load $R_L = 500 \Omega$	126 μ s	380 μ s
Ohmic/capacitive load $R_L = 500 \Omega / C_L = 10 \text{ nF}$	140 μ s	425 μ s
Ohmic/capacitive load $R_L = 500 \Omega / C_L = 220 \text{ nF}$	350 μ s	1200 μ s
Ohmic/inductive load $R_L = 500 \Omega / L_L = 3.3 \text{ mH}$	110 μ s	368 μ s

Signal rise times: Current output 4 mA to 20 mA (typical values)

	10% to 90%	0% to > 99%
Ohmic load $R_L = 500 \Omega$	140 μ s	508 μ s
Ohmic/capacitive load $R_L = 500 \Omega / C_L = 10 \text{ nF}$	145 μ s	534 μ s
Ohmic/capacitive load $R_L = 500 \Omega / C_L = 220 \text{ nF}$	380 μ s	1200 μ s
Ohmic/inductive load $R_L = 500 \Omega / L_L = 3.3 \text{ mH}$	116 μ s	410 μ s

Tolerance and temperature response of the outputs for $T_A = 25^\circ\text{C}$

Output range	Absolute tolerance		Relative tolerance	
	Typical	Maximum	Typical	Maximum
0 V to 10 V	$\pm 0.8 \text{ mV}$	$\pm 2.0 \text{ mV}$	$\pm 0.008\%$	$\pm 0.02\%$
0 mA to 20 mA	$\pm 2 \mu\text{A}$	$\pm 6 \mu\text{A}$	$\pm 0.01\%$	$\pm 0.03\%$
4 mA to 20 mA	$\pm 2 \mu\text{A}$	$\pm 6 \mu\text{A}$	$\pm 0.01\%$	$\pm 0.03\%$

Tolerance and temperature response of the outputs for $T_A = -25^\circ\text{C}$ to $+55^\circ\text{C}$

Output range	Temperature coefficient	
	Typical	Maximum
0 V to 10 V	$\pm 8 \text{ ppm/K}$	$\pm 25 \text{ ppm/K}$
0 mA to 20 mA	$\pm 18 \text{ ppm/K}$	$\pm 45 \text{ ppm/K}$
4 mA to 20 mA	$\pm 18 \text{ ppm/K}$	$\pm 45 \text{ ppm/K}$



Outside the specified range, tolerances at the analog outputs might increase when gradually switching off the 24 V supply voltage U_{ANA} . They occur below $U_{ANA} = +13.5 \text{ V}$. If U_{ANA} continues to fall, an I/O error is triggered.



All **percentage** tolerance values refer to the relevant measuring range final value. The **maximum** tolerance values contain the theoretical maximum possible tolerances. The validity of the values is 12 months at least. The data refers to nominal operation (installation on horizontal DIN rail, $U_S = 24 \text{ V}$). Please also observe the values for temperature drift and the tolerances under EMC influences. The tolerances for the different voltage and current output areas are documented with a high level of accuracy for the keying.

Additional tolerances influenced by electromagnetic fields

Type of electromagnetic interference	Typical deviation from the output range final value (voltage output)	Typical deviation of the output range final value (current output)
	Relative	Relative
Electromagnetic fields; Field strength 10 V/m according to EN 61000-4-3/IEC 61000-4-3	< 0.1%	< 0.1%
Conducted interference Class 3 (test voltage 10 V) according to EN 61000-4-6/IEC 61000-4-6	< 0.1%	< 0.3%
Fast transients (burst) 2 kV supply, 1 kV output according to EN 61000-4-4/IEC 61000-4-4	Class A	Class A
Fast transients (burst) 4 kV supply, 2 kV output according to EN 61000-4-4/IEC 61000-4-4	Class B	Class B

Protective equipment

Transient protection for voltage and current outputs

Electrical isolation/isolation of the voltage areas

Electrical isolation of the logic level from the I/O area is ensured through optocouplers and the DC/DC converters.

Common potentials

24 V I/O voltage, 24 V segment voltage, and GND have the same potential. FE is a separate potential area.

Separate potentials in the system consisting of bus coupler/power terminal and I/O terminal**Test distance**

7.5 V supply (bus logic), 24 V supply U_{ANA} / I/O

7.5 V supply (bus logic), 24 V supply U_{ANA} /functional earth ground

24 V supply (I/O) / functional earth ground

Test voltage

500 V AC, 50 Hz, 1 min.

500 V AC, 50 Hz, 1 min.

500 V AC, 50 Hz, 1 min.

Error messages to the higher-level control or computer system

Failure or insufficient analog supply voltage U_{ANA}

Yes, I/O error message sent to the bus coupler

Approvals

For the latest approvals, please visit www.phoenixcontact.net/catalog.

4 Local diagnostic and status indicators and terminal point assignment

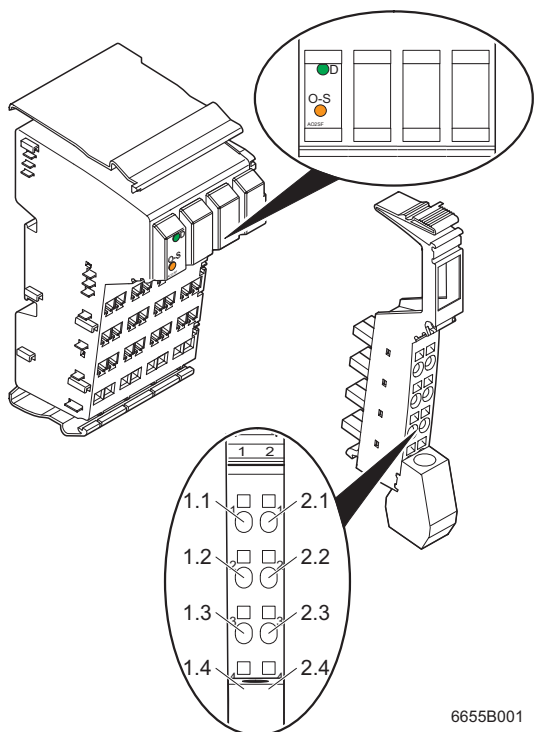

6655B001

Figure 1 Terminal with an appropriate connector

4.1 Local diagnostic and status indicators

Des.	Color	Meaning
D	Green	Diagnostics
O-S	Orange	Original default state parameterized

Note on the O-S LED:

By default upon delivery, the terminal parameters are set as follows:

Data format:	IB IL
Behavior of the outputs in the event of an error (fail-safe):	Outputs hold the last value (hold)

As soon as these parameters are identified on the terminal, the O-S LED will light up. If at least one of the parameters is different (because of non-volatile or volatile parameterization) the LED will not light up.

After power up the non-volatile stored parameterization always becomes valid.

4.2 Function identification

Yellow

2 Mbps: White stripe in the vicinity of the D LED

4.3 Terminal point assignment

Connector	Terminal point	Signal	Assignment
1	1.1, 2.1	+U	Voltage output of channel 1
	1.2, 2.2	B1	Jumper 1
	1.3, 2.3	AGND	Analog ground
	1.4, 2.4	Shield	Shield connection
2	1.1	+I ₀₋₂₀	Current output of channel 1 0 mA to 20 mA
	2.1	+I ₄₋₂₀	Current output of channel 1 4 mA to 20 mA
	1.2, 2.2	B2	Jumper 2
	1.3, 2.3	AGND	Analog ground
	1.4, 2.4	Shield	Shield connection
3	1.1, 2.1	+U	Voltage output of channel 2
	1.2, 2.2	B1	Jumper 1
	1.3, 2.3	AGND	Analog ground
	1.4, 2.4	Shield	Shield connection
4	1.1	+I ₀₋₂₀	Current output of channel 2 0 mA to 20 mA
	2.1	+I ₄₋₂₀	Current output of channel 2 4 mA to 20 mA
	1.2, 2.2	B2	Jumper 2
	1.3, 2.3	AGND	Analog ground
	1.4, 2.4	Shield	Shield connection

5 Installation instructions

High current flowing through potential jumpers U_M and U_S leads to a temperature rise in the potential jumpers and inside the terminal. To keep the current flowing through the potential jumpers of the analog terminals as low as possible, always place the analog terminals after all the other terminals at the end of the main circuit. (For the sequence of the Inline terminals: see also IL SYS INST UM E user manual or Inline system manual for your bus system).

6 Installation instruction

Installing jumpers may influence the accuracy of the channels independently of each other. Without using jumpers the voltage channels have a high level of accuracy and the current channels have a low level of accuracy. Installing a jumper for a channel increases the accuracy of a current output. This also reduces the accuracy of the voltage output. Only install the jumper when using a current channel. Installing a jumper when using a voltage channel will not be indicated as an error. Changing the jumper will only take effect upon power up.

Encoding table

Representation in Figure 2	Connector	Jumper	Status	Meaning
A	X*	J1	Not installed	High level of accuracy 0 V to +10 V
	Y*	J2	Not installed	
B	X*	J1	Installed	High level of accuracy 0 mA to +20 mA
	Y*	J2	Not installed	
C	X*	J1	Not installed	High level of accuracy 4 mA to +20 mA
	Y*	J2	Installed	

X*Y* represent connectors 1 and 2 (channel 1) or connectors 3 and 4 (channel 2).

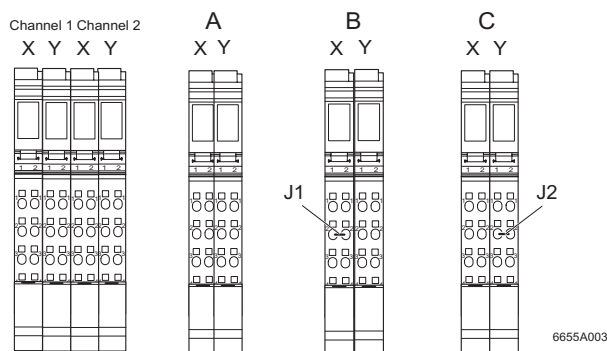

Figure 2 Figure for the encoding table

7 Internal basic circuit diagram

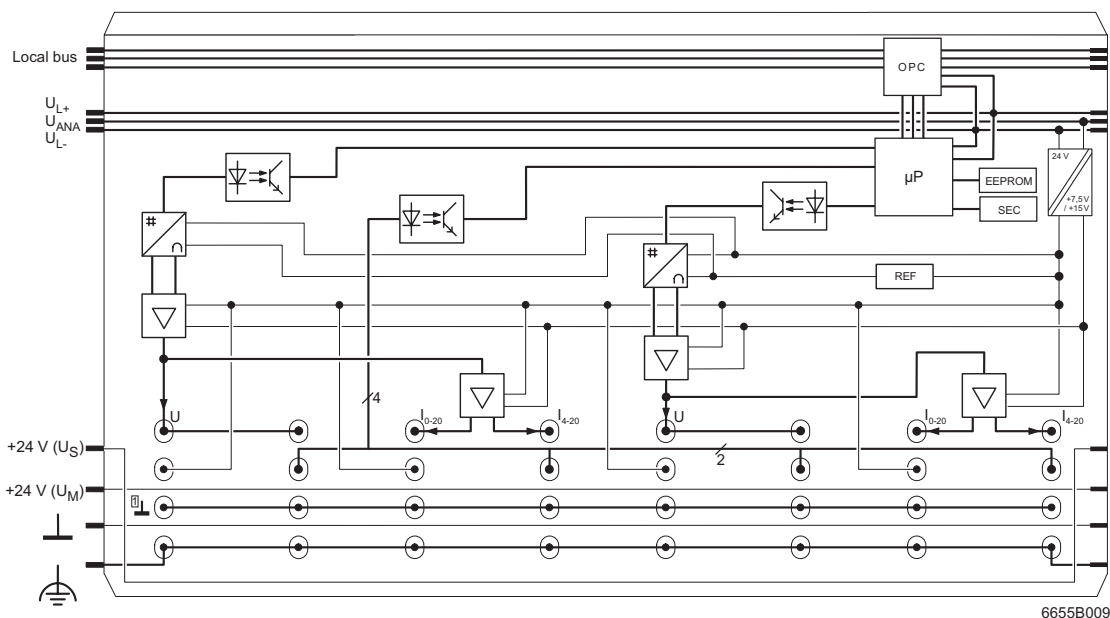











Figure 3 Internal basic circuit diagram

Key:

	Protocol chip		Reference voltage
	Optocoupler		Amplifier
	Microprocessor		Digital/analog converter
	Protective circuit (security)		Analog ground, electrically isolated from ground of the potential jumper
	Electrically erasable re-programmable read-only memory		
	DC/DC converter with electrical isolation		



Other symbols used are explained in the IL SYS INST UM E user manual.

8 Electrical isolation

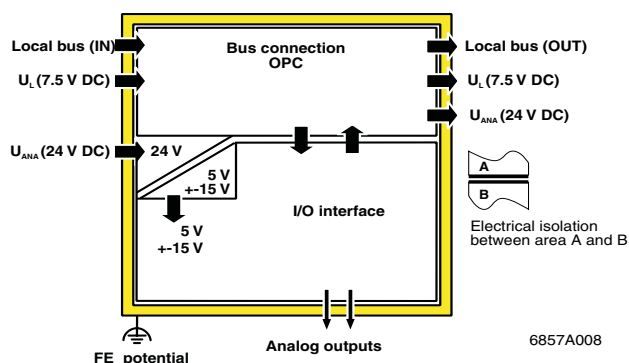

Figure 4 Electrical isolation of the individual function areas

9 Connection notes

Always connect the analog actuators using shielded, twisted pair cables.

At the terminal, connect one end of the shielding to FE. At the module, fold the outer cable sheath back and connect the shield to the terminal via the shield connection clamp. The clamp connects the shield directly to FE on the module side.

When using cables longer than 10 m in environments prone to interference, we recommend connecting the shield on the actuator to the FE potential additionally via an RC element. The capacitor C should typically have values of 1 nF to 15 nF. The resistor R should have a resistance of at least 10 MΩ.

10 Connection examples



Use connectors with shield connection when installing the actuator. On free slots you may use one of the connectors listed in the ordering data. Figure 5 and Figure 6 show the connection schematically (without shield connector).

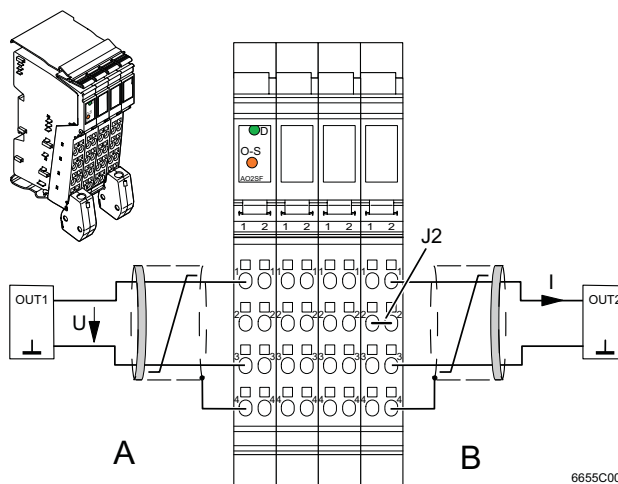

Figure 5 Actuator connection to the voltage and current outputs using 2-wire technology with shield connection

A: Channel 1, signals for an actuator at the voltage output 0 V to 10 V

B: Channel 2, signals for one actuator at the current output 4 mA to 20 mA with high precision

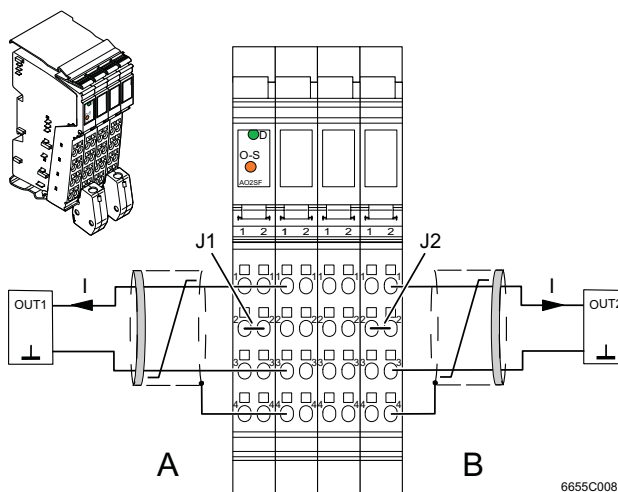

Figure 6 Actuator connection to the current outputs using 2-wire technology with shield connection

J1, J2: External jumpers

A: Channel 1, signals for an actuator at the current output 0 mA to 20 mA with a high level of accuracy

B: Channel 2, signals for an actuator at the current output 4 mA to 20 mA with a high level of accuracy

11 Programming data/ configuration data

11.1 Local bus (INTERBUS)

ID code	5B _{hex} (91 _{dec})
Length code	02 _{hex}
Process data channel	32 bits
Input address area	2 words
Output address area	2 words
Parameter channel (PCP)	0 bytes
Register length (bus)	2 words

11.2 Other bus systems



For the programming data of other bus systems, please refer to the corresponding electronic device data sheet (e.g., GSD, EDS).

12 Process data



For the assignment of the illustrated (byte.bit) view to your **INTERBUS** control or computer system, please refer to the DB GB IBS SYS ADDRESS data sheet.

12.1 Assignment of the terminal points to OUT process data

(Word.Bit) view	Word	Word 0															
	Bit	15	14	13	12	11	10	9	8	7	6	5	4	3	2	1	0
(Byte.Bit) view	Byte	Byte 0								Byte 1							
	Bit	7	6	5	4	3	2	1	0	7	6	5	4	3	2	1	0
Assignment	IB IL format	SB	Output value channel 1														
Assignment	IB ST format	SB	Output value channel 1												0	0	0
Terminal points slot 1	Signal	Terminal point 1.1.1: Voltage output															
	AGND	Terminal point 1.1.3, 1.2.3															
	Shielding (FE)	Terminal point 1.1.4, 1.2.4															
Terminal points slot 2	Signal	Terminal point 2.1.1: Current output 0 mA to 20 mA Terminal point 2.2.1: Current output 4 mA to 20 mA															
	AGND	Terminal point 2.1.3, 2.2.3															
	Shielding (FE)	Terminal point 2.1.4, 2.2.4															
(Word.Bit) view	Word	Word 1															
	Bit	15	14	13	12	11	10	9	8	7	6	5	4	3	2	1	0
(Byte.Bit) view	Byte	Byte 2								Byte 3							
	Bit	7	6	5	4	3	2	1	0	7	6	5	4	3	2	1	0
Assignment	IB IL format	SB	Output value channel 2														
Assignment	IB ST format	SB	Output value channel 2												0	0	0
Terminal points slot 3	Signal	Terminal point 3.1.1: Voltage output															
	AGND	Terminal point 3.1.3, 3.2.3															
	Shielding (FE)	Terminal point 3.1.4, 3.2.4															
Terminal points slot 4	Signal	Terminal point 4.1.1: Current output 0 mA to 20 mA Terminal point 4.2.1: Current output 4 mA to 20 mA															
	AGND	Terminal point 4.1.3, 4.2.3															
	Shielding (FE)	Terminal point 4.1.4, 4.2.4															

SB Sign bit

0 In "IB ST" format bits 2 through 0 are irrelevant. Set these bits to "0".

12.2 Assignment of the IN process data

(Word.Bit) view	Byte	Word 0														
	Bit	15	14	13	12	11	10	9	8	7	6	5	4	3	2	1
(Byte.Bit) view	Byte	Byte 0							Byte 1							
	Bit	7	6	5	4	3	2	1	0	7	6	5	4	3	2	1
Assignment		SB	Mirrored channel 1 output value											F	0	H
(Word.Bit) view	Byte	Word 1														
	Bit	15	14	13	12	11	10	9	8	7	6	5	4	3	2	1
(Byte.Bit) view	Byte	Byte 2							Byte 3							
	Bit	7	6	5	4	3	2	1	0	7	6	5	4	3	2	1
Assignment		SB	Mirrored channel 2 output value											F	0	H

- SB Sign bit
- F Format of output data
- H HOLD/RESET

12.3 OUT process data

The OUT process data specifies the output values in each cycle.

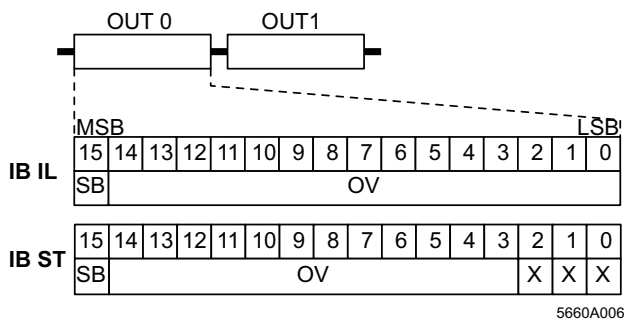

Figure 7 OUT process data words in IB IL and IB ST formats

- OUT Process data output word
- MSB Most significant bit
- LSB Least significant bit
- SB Sign bit
- OV Output value
- X Irrelevant bit

i Set the irrelevant bits to 0.

12.4 IN process data

Bits 15 through 3 of the process data output values are mirrored in the IN process data. Bit 15 is the sign bit. Bits 2 through 0 are available as status bits. The bits contain information on the parameterized behavior of the terminal.

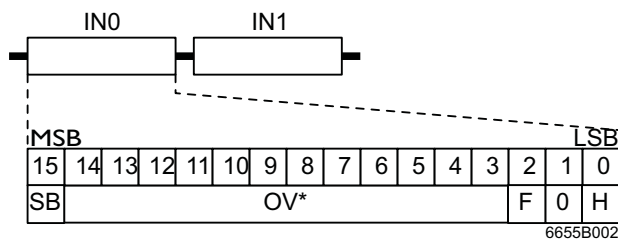

Figure 8 IN process data words

- IN Process data input word
- MSB Most significant bit
- LSB Least significant bit
- SB Sign bit
- OV* Mirrored output value
- F Format of output data
- H HOLD/RESET

Bits 2 through 0 have the following meaning:

Bit	Designation	Meaning	Bit x = 0	Bit x = 1
2	F	Format of output data	IB IL	IB ST
1		Reserved		
0	H	HOLD/RESET see page 15	HOLD	RESET

13 Formats for representing the output values

"IB IL" is the default format on the terminal. To ensure that the terminal can be operated in the ST data format, the output value representation can be switched to the "IB ST" format.

13.1 "IB IL" format

The output value is represented in bits 14 through 0. An additional bit (bit 15) is available as a sign bit. The sign bit is 0 for the output value 0 V to 10 V. If the sign bit is 1, which corresponds to a negative value, the value 0 V (or 0 mA/4 mA) is output.

15	14	13	12	11	10	9	8	7	6	5	4	3	2	1	0
SB	OV														

SB Sign bit

OV Output value



Bits 2 through 0 are not mirrored in the input data.

13.2 Significant output values in the "IB IL" format

The terminal has two analog output channels, which are able to output voltages in the range of 0 V to +10 V or currents in the range of 0 mA to 20 mA and 4 mA to 20 mA with a resolution of 15 bits plus the sign bit.

Value range 0 V to +10 V

Area	Output data word (two's complement)		Output range		
			0 V to +10 V U_{Output}	0 mA to +20 mA I_{Output}	+4 mA to +20 mA I_{Output}
			hex	dec	V
Overflow	7FFF	32767	+10.8373	+ 21.6764	+ 21.3397
	7F01	32513	+10.8373	+ 21.6764	+ 21.3397
Overload capability range	7F00	32512	+10.8373	+ 21.6764	+ 21.3397
	7531	30001	+10.0003	+ 20.0007	+ 20.0005
Nominal range	7530	30000	+10.0000	+ 20.0000	+ 20.0000
	3A98	15000	5.0000	+10.0000	+12.0000
	0001	1	+ 333.33 x 10 ⁻⁶	+ 0.667 x 10 ⁻⁶	+ 4.000533
	0000	0	0	0	+ 4.000
Underflow	< 0000	< 0	0	0	+ 4.000

13.3 "IB ST" format

The output value is represented in bits 14 through 3. Bit 15 is available as sign bit. Bits 2 through 0 are irrelevant.

This format corresponds to the data format used on INTERBUS ST modules.

15	14	13	12	11	10	9	8	7	6	5	4	3	2	1	0
SB	OV												x	x	x

SB Sign bit

OV Output value

X Irrelevant bit (set this bit to 0.)



Bits 2 through 0 are not mirrored in the input data.

Significant output values in the "IB ST" format

Value range 0 V to 10 V and 0 mA to 20 mA

Output data word (two's complement)	0 V to +10 V U_{Output}	0 mA to +20 mA I_{Output}
hex	V	mA
> 7FF8	9.9975	19.9951
7FF8	9.9975	19.9951
4000	5.0000	10.0000
0008	0.0024	0.0048
≤0000	0	0

Value range 4 mA to 20 mA

Output data word (two's complement)	4 mA to +20 mA I_{Output}
hex	mA
>7FFC	19.9961
7FFC	19.9961
4000	12.0000
000C	4.003906
≤0004	4.0000



All three ranges are available in parallel for this terminal. Therefore, bit 2, which is designed to distinguish the measuring ranges 0 mA to 20 mA/ 4 mA to 20 mA in the ST format, is irrelevant.

14 Output behavior

14.1 Output behavior during error-free operation (normal operation)

After power up the stored values for the data format and the behavior of the outputs are read in the event of an error (reset value). These are either the values of the configuration upon delivery or a non-volatile stored configuration.

The data format and the behavior of the outputs in the event of an error can be parameterized non-volatile or volatile by a process data sequence during runtime (see "Parameterization" on page 17).

14.2 Output behavior in the event of an error (fail-safe)

In the event of an error the outputs respond according to the parameterization (see "Parameterization" on page 17). That means the outputs hold the last value (HOLD, default setting) or they return to zero (RESET, can be parameterized).



Take the output behavior in the event of an error into account when configuring your system, especially a fail-safe behavior that was possibly parameterized twice (for the bus coupler and the analog terminal).

14.3 Output behavior of the voltage and current outputs

Switching operation/state of the supply voltage	Marginal condition	Process data word OUT (hex)	Behavior/status of the analog output		
			0 V to 10 V	0 mA to 20 mA	4 mA to 20 mA
U_{ANA} from 0 V to 24 V	$U_L = 0$ V	xxxx	0 V	0 mA	4 mA
U_{ANA} from 24 V to 0 V	$U_L = 7.5$ V	xxxx	0 V	0 mA	0 mA
Local bus stopped	$U_{ANA} = 0$ V	xxxx	0 V	0 mA	0 mA
Local bus stopped	$U_{ANA} = 24$ V	xxxx	Hold last value		
Bus reset (e.g., remote bus cable break)		xxxx	Can be parameterized: Hold last value (default setting)		
			0 V	0 mA	4 mA

U_{ANA} Analog supply voltage of the terminal

U_L Supply voltage for module electronics (communications power)

xxxx Any value in the range from 0000_{hex} to FFFF_{hex}

14.4 Response of the voltage and current outputs to a control command of the controller board

Command	State after switching operation			
	OUT process data word (hexadecimal)	Analog output		
		0 V to 10 V	0 mA to 20 mA	4 mA to 20 mA
STOP	xxxx	Hold last value		
ALARM STOP (reset)	xxxx	Can be parameterized: Hold last value (default setting)		
		0 V	0 mA	4 mA

15 Input data in normal operation and in the event of an error

During **error-free operation (normal operation)** the output data is mirrored in the input words as "acknowledgment" in bits 15 through 3 as soon as it has been transmitted to the DAC.

Bits 2 through 0 are available as status bits and are used to display and read the set behavior of the terminal (see "IN process data" on page 12).

If an **error** is detected by the terminal, it is indicated by means of an error code in the first or second process IN process data word depending on the error type. Possible error codes are given in the following table.

Error codes:

Output data word (two's complement) hex	Cause	Remedy
8010	The jumpers for selecting the "high accuracy" range are contradictory (e.g., 0 mA to 20 mA and at the same time 4 mA to 20 mA). The error message is indicated on the corresponding channel only.	Connect the jumpers correctly.
	The user parameterization cannot be stored. The error message is indicated on both channels.	Carry out a power up.
8020	Error in the I/O voltage supply	Check the voltage supply on the bus coupler. Check that the potential jumpers are connecting safely. Replace the terminal.
8040	Terminal is defective.	Replace the terminal.



An I/O error is triggered with codes 8020_{hex} and 8040_{hex}.



The error codes overwrite the status bits (bits 2 through 0) with "0".

16 Parameterization

By default upon delivery, the terminal parameters are set as follows:

Data format:	IB IL
Behavior of the outputs in the event of an error:	Outputs hold the last value (Hold)

The following terminal parameters can be configured according to your conditions using the process data:

Data format:	IB ST
Behavior of the outputs in the event of an error (fail-safe):	Outputs are set to 0 (reset)

In order to parameterize the terminal you must change to parameterization mode.

Steps to be taken to parameterize the terminal:

Step 1:	<p>Transmission of code 8030_{hex} in the first OUT process data word.</p> <p>In bits 15 through 3 of the first IN process data word this code is acknowledged as a normal process data item.</p>																																																			
Step 2:	<p>Transmission of the parameterization code in the second OUT process data word.</p> <table border="1"> <tr> <td>Bit</td> <td>15</td> <td>14</td> <td>13</td> <td>12</td> <td>11</td> <td>10</td> <td>9</td> <td>8</td> <td>7</td> <td>6</td> <td>5</td> <td>4</td> <td>3</td> <td>2</td> <td>1</td> <td>0</td> </tr> <tr> <td>bin</td> <td>1</td> <td>0</td> <td>0</td> <td>0</td> <td>0</td> <td>0</td> <td>0</td> <td>0</td> <td>0</td> <td>1</td> <td>0</td> <td>1</td> <td>p₃</td> <td>p₂</td> <td>0</td> <td>p₁</td> </tr> <tr> <td>hex</td> <td colspan="4">8</td> <td colspan="4">0</td> <td colspan="4">5</td> <td colspan="4">X</td> </tr> </table> <p>Where p_x are the terminal parameters: p₃: Volatile or non-volatile (0: Volatile; 1: Non-volatile) p₂: Data format (0: IB IL; 1: IB ST) p₁: Reset behavior (0: Hold; 1: Reset)</p> <p>Both output data words must be written with a maximum time of 10 s between each other. This makes data consistency over two words unnecessary. The writing sequence is not important. If the time has elapsed, something else, differing from the parameter value, must be written in the two words. The parameter words must be kept for 2 s until the parameterization is accepted.</p>	Bit	15	14	13	12	11	10	9	8	7	6	5	4	3	2	1	0	bin	1	0	0	0	0	0	0	0	0	1	0	1	p ₃	p ₂	0	p ₁	hex	8				0				5				X			
Bit	15	14	13	12	11	10	9	8	7	6	5	4	3	2	1	0																																				
bin	1	0	0	0	0	0	0	0	0	1	0	1	p ₃	p ₂	0	p ₁																																				
hex	8				0				5				X																																							
Step 4:	<p>Acceptance of the value is confirmed in bits 15 through 3 of the first input word through mirroring of the code. No timer is required in the application as monitoring the input data is sufficient. When mirroring, note that bits 2 through 0 still indicate the current terminal parameterization in each word. As soon as the new parameterization is valid the corresponding parameter bit is set in the input data.</p>																																																			
Step 5:	<p>The terminal is in normal process data mode again. Prior to a new parameterization, the data on both output words must have changed.</p>																																																			



The orange O-S LED on the terminal indicates whether the original configuration is present or whether the active configuration differs from the default configuration of the terminal upon delivery. The LED is on if the default state has been parameterized (see also "Local diagnostic and status indicators" on page 6).



SCATTERGOOD & JOHNSON LTD

ELECTRICAL ENGINEERING & FLUID CONTROL DISTRIBUTORS

Est.1899

At Scattergood & Johnson Ltd, we pride ourselves on being a technical distributor to specialist industries.

Working with a range of quality product suppliers across a number of specialist markets, we are not your average 'box shifter' - we are your technical and supply chain partner.

We fully support every product we sell - for free! Our internal team and external sales engineers can answer any product or application question, no matter the complexity.

Backing up this technical ability is a range of 50,000+ products available from stock for nationwide next day delivery (same day if required!), or you can collect what you need from any of our trade counters around the UK.

Select your specialist interest below to learn more about how we can help.

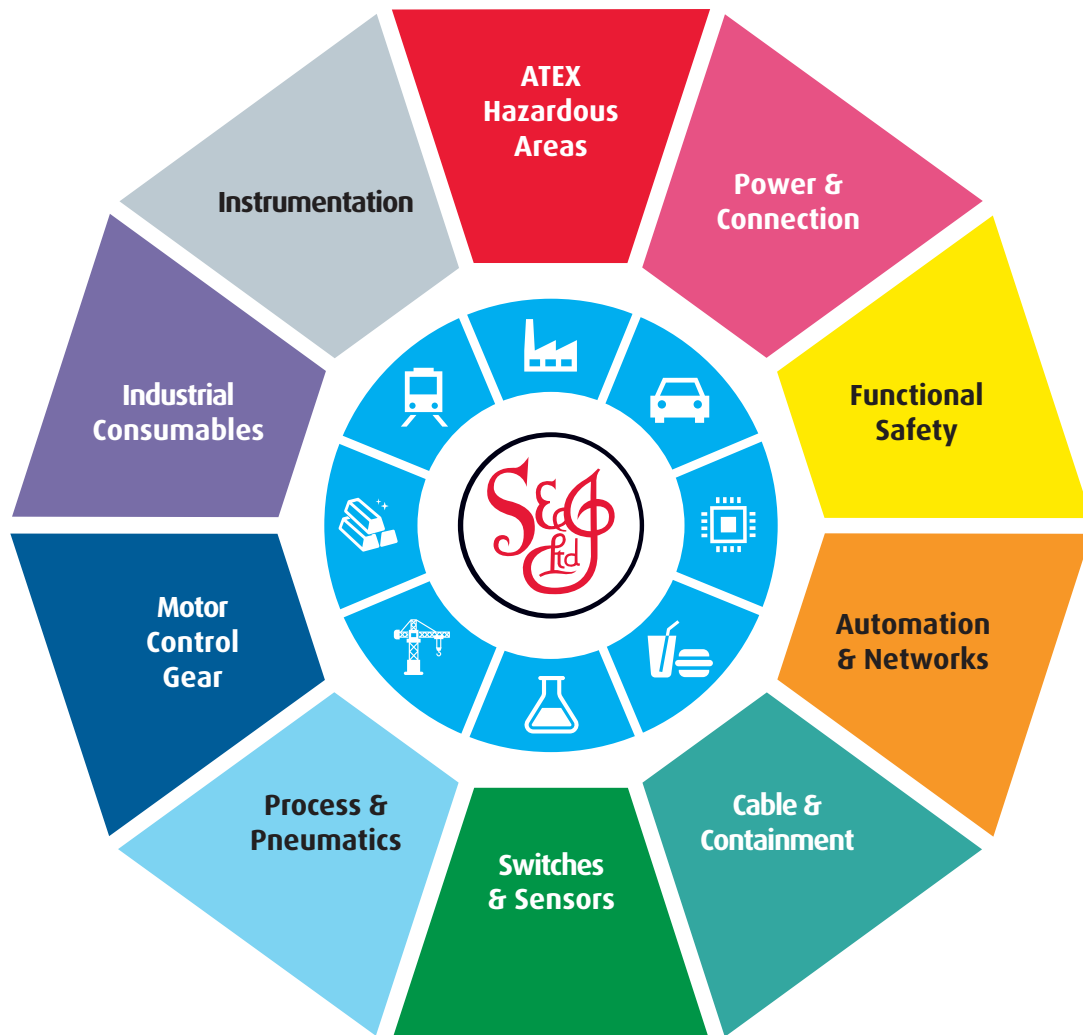

Online, In Branch and On the Road - Scattergood & Johnson Ltd, there when you need us.

www.scatts.co.uk