



ILB PB 24 DI8 DIO8 (/CN)

Inline Block IO Module for PROFIBUS With Eight Digital Inputs and Eight Digital Inputs or Outputs

AUTOMATIONWORX

Data Sheet
6992_en_03

© PHOENIX CONTACT - 03/2007

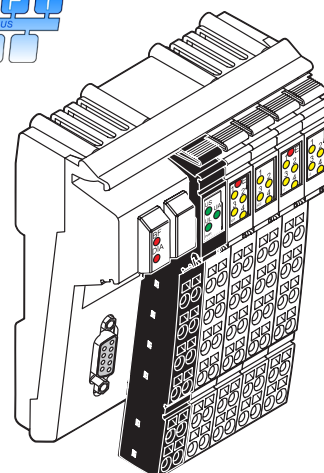

Description

The ILB PB 24 DI8 DIO8 (/CN) module is designed for use within a PROFIBUS network. It is used to acquire and output digital signals.

PROFIBUS-DP Features

- Bus connection via D-SUB connectors
- Rotary encoding switches for address setting
- Supported PROFIBUS addresses 1 to 99
- Transmission speed 9.6 kbaud to 12 Mbaud (autobaud)
- Diagnostic and status indicators
- Device description via GSD file

Input Features

- Connections for eight digital sensors
- Connection of sensors in 2 and 3-wire technology
- Maximum permissible load current per sensor: 250 mA
- Maximum permissible load current from the sensor supply: 2.0 A
- Diagnostic and status indicators

Combined Input and Output Features

- Connections for eight digital sensors/actuators
- Each individual channel can be used as an input or output
- Connection of sensors in 2 and 3-wire technology
- Maximum permissible load current per sensor: 250 mA
- Maximum permissible load current from the sensor supply: 2.0 A
- Connection of actuators in 2-wire technology
- Nominal current per output: 0.5 A
- Total current of all outputs: 4 A
- Short-circuit and overload protected outputs
- Diagnostic and status indicators



Please refer to the "Mounting and Removing Inline Block IO Modules" application note (see "Ordering Data" on page 2).



Make sure you always use the latest documentation.
It can be downloaded at www.download.phoenixcontact.com.
Here you will also find the current GSD file.

A conversion table is available on the Internet at
www.download.phoenixcontact.com/general/7000_en_00.pdf.



This data sheet is valid for the products listed on the following page:

Ordering Data

Products

Description	Type	Order No.	Pcs./Pkt.
Inline Block IO module for PROFIBUS with eight digital inputs and eight digital inputs or outputs, terminal points of the connectors have identical numbering	ILB PB 24 DI8 DIO8	2863562	1
Inline Block IO module for PROFIBUS with eight digital inputs and eight digital inputs or outputs, terminal points of the connectors have continuous numbering	ILB PB 24 DI8 DIO8/CN	2878845	1

Accessories: Connector

Description	Type	Order No.	Pcs./Pkt.
9-pos. D-SUB connector for connecting PROFIBUS	SUBCON-PLUS-PROFIB	2744348	1

Accessories: Connectors as Replacement Item

Description	Type	Order No.	Pcs./Pkt.
Connector for the supply (color print)	ILB SCN-12-PWR IN-CP	2863164	10
Connector, with color print, for digital 4-channel or 16-channel Inline input terminals	IB IL SCN-12-ICP	2727611	10

Accessories: Other

Description	Type	Order No.	Pcs./Pkt.
Recommended end clamp; placed both to the right and left of the module to secure it on the DIN rail	CLIPFIX 35-5	3022276	50

Documentation

Description	Type	Order No.	Pcs./Pkt.
"Mounting and Removing Inline Block IO Modules" application note	AH ILB INSTALLATION	9014931	1

Technical Data

General Data

Housing dimensions with connectors (width x height x depth)	95 mm x 55 mm x 141 mm
Weight	280 g (with connectors)
Operating mode	Process data mode with 2 bytes
Transmission speed	9.6 kbaud to 12 Mbaud (autobaud)
Type of sensor and actuator connection	2 and 3-wire technology

Housing Dimensions

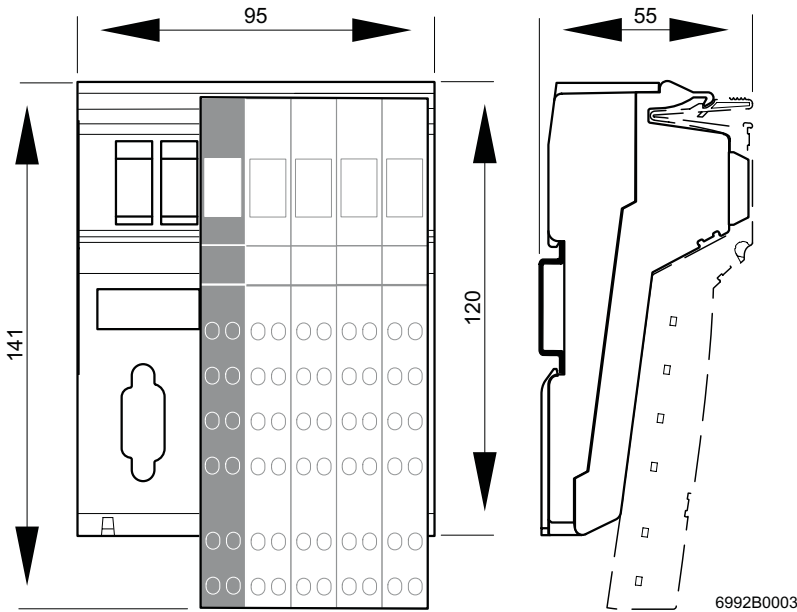

Figure 1 Housing dimensions of the module (dimensions in mm)

Ambient Conditions

Regulations	Developed according to VDE 0160/EN 50178/IEC 62103, UL 508
Ambient temperature (operation)	-25°C to +60°C
Ambient temperature (storage/transport)	-25°C to +85°C
Humidity (operation/storage/transport)	10% to 95% according to EN 61131-2
Air pressure (operation)	80 kPa to 108 kPa (up to 2000 m above sea level)
Air pressure (storage/transport)	66 kPa to 108 kPa (up to 3500 m above sea level)
Degree of protection according to IEC 60529	IP20
Class of protection	Class 3 according to VDE 0106/IEC 60536
Air and creepage distances	According to DIN VDE 0110/IEC 60664, IEC 60664A, DIN VDE 0160/EN 50178/IEC 62103
Housing material	Plastic, PVC-free, PBT, self-extinguishing (V0)
Pollution degree according to EN 60664-1/IEC 60664-1, EN 61131-2/IEC 61131-2	2; condensation not permitted during operation
Surge voltage class	II

Electrical Isolation/Isolation of the Voltage Areas**Test Distance**

PROFIBUS / I/O	500 V AC, 50 Hz, 1 min
PROFIBUS / functional earth ground	500 V AC, 50 Hz, 1 min
I/O / functional earth ground	500 V AC, 50 Hz, 1 min

Test Voltage**Mechanical Requirements**

Vibration test, sinusoidal vibrations according to EN 60068-2-6/IEC 60068-2-6	5g load, 2.5 hours in each space direction
Shock test according to EN 60068-2-27/IEC 60068-2-27	25g load for 11 ms, half sinusoidal wave, 3 shocks in each space direction and orientation
Broadband noise according to EN 60068-2-64/IEC 60068-2-64	0.78g load, 2.5 hours in each space direction

Conformance With EMC Directive 89/336/EEC**Noise Immunity Test According to EN 61000-6-2**

Electrostatic discharge (ESD)	EN 61000-4-2 IEC 61000-4-2	Criterion B 6 kV contact discharge 8 kV air discharge
Electromagnetic fields	EN 61000-4-3 IEC 61000-4-3	Criterion A Field strength: 10 V/m
Fast transients (burst)	EN 61000-4-4/ IEC 61000-4-4	Criterion B Remote bus: 2 kV Power supply: 2 kV I/O cables: 2 kV Criterion A All interfaces: 1 kV
Surge voltage	EN 61000-4-5 IEC 61000-4-5	Criterion B DC supply lines: ± 0.5 kV/ ± 1.0 kV (symmetrical/asymmetrical) Signal cables: ± 0.5 kV/ ± 0.5 kV (symmetrical/asymmetrical)
Conducted interference	EN 61000-4-6 IEC 61000-4-6	Criterion A Test voltage 10 V

Noise Emission Test According to EN 61000-6-4

Noise emission of housing	EN 55011	Class A
---------------------------	----------	---------

Interface

PROFIBUS interface	Copper cable (RS-485); connected via D-SUB connector; shielding directly connected with functional earth ground
--------------------	---

24 V Module Supply (Communications Power, Sensor Supply, and Actuator Supply; U_L , U_S , and U_A)

Nominal value	24 V DC
Tolerance	-15%/+20% according to EN 61131-2
Ripple	$\pm 5\%$ according to EN 61131-2
Permissible range	19.2 V DC to 30.0 V DC
Current consumption at U_L	60 mA
Current consumption at U_S	4 A
Current consumption at U_A	4 A
Safety equipment for communications power	Surge protection and protection against polarity reversal
Safety equipment for the sensor supply	Surge, overload and short-circuit protection
Safety equipment for the actuator supply	Surge protection
Connection	Via power connectors

Digital Outputs

Number	8 (freely selectable)
Connection method for actuators	2-wire technology
Nominal output voltage U_{OUT}	24 V DC
Differential voltage at I_{nom}	≤ 1 V
Nominal current I_{nom} per channel	0.5 A
Total current	4 A
Protection	Short-circuit and overload protection
Nominal load	
Ohmic	48 Ω /12 W
Lamp	12 W
Inductive	12 VA (1.2 H, 50 Ω)
Switching frequency with nominal inductive load	0.5 Hz (1.2 H, 50 Ω), maximum
Overload response	Auto restart
Response with inductive overload	Output may be damaged
Reverse voltage protection against short pulses	Protected against reverse voltages
Resistance to permanently applied reverse voltages	Protected against reverse voltages, permissible current 2 A, maximum
Validity of output data after connecting the 24 V supply voltage (power up)	5 ms, typical
Response upon power down	The output follows the supply voltage without delay.
Limitation of the voltage induced on circuit interruption	-41.0 V
One-time unsolicited energy	1 J, maximum
Protective circuit type	Integrated free running circuit in the output chip
Overcurrent shutdown	0.7 A, minimum
Maximum output current when switched off	10 μ A



When not loaded, a voltage can be measured even at an output that is not set.

Digital Inputs

Number	16 (8 permanent, 8 freely selectable)
Connection method for sensors	2 and 3-wire technology
Input design	According to EN 61131-2 Type 1
Definition of switching thresholds	
Maximum low-level voltage	$U_{Lmax} < 5$ V
Minimum high-level voltage	$U_{Hmin} > 15$ V
Common potentials	Sensor supply U_S , ground
Nominal input voltage U_{IN}	24 V DC
Permissible range	-30 V $< U_{IN} < +30$ V DC
Nominal input current for U_{IN}	5 mA, typical
Current flow	Linear in the range 1 V $< U_{IN} < 30$ V
Delay time	≤ 500 μ s
Permissible cable length to the sensor	100 m
Use of AC sensors	AC sensors in the voltage range $< U_{IN}$ are limited in application

Typical Power Dissipation With 24 V Supply Voltage

Formula to Calculate the Power Dissipation of the Electronics

$$P_{TOT} = 1.44 \text{ W} + (I_{S23}^2 + I_{S45}^2) \times 0.06 \Omega + \sum_{i=1}^n (0.129 \text{ W} + I_{Li}^2 \times 0.28 \Omega + I_{Li} \times 0.35 \text{ V}) + \sum_{j=1}^m 0.125 \text{ W}$$

Where

- P_{TOT} Total power dissipation of the module
- I_{S23} Current from the sensor supply at slots 2 and 3
- I_{S45} Current from the sensor supply at slots 4 and 5
- i Index
- n Number of set outputs (n = 1 to 8)
- I_{Li} Load current of the output i
- j Index
- m Number of set inputs (m = 1 to 16)

Limitation of Simultaneity

No limitation of simultaneity, derating

Derating

Ambient Temperature (T_A)

Total Current (I_{TOT})

Outputs, Connectors 2 and 3

-25°C to +30°C

4 A

+30°C to +60°C

4 A - ((T_A - 30°C) x 0.08 A/°C)

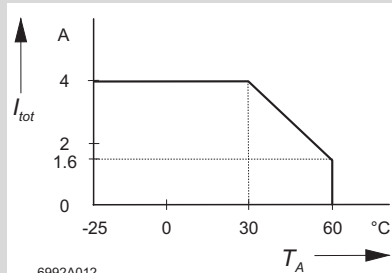

Sensor Supply, Connectors 2 and 3

-25°C to +30°C

2 A

+30°C to +60°C

2 A - ((T_A - 30°C) x 0.033 A/°C)

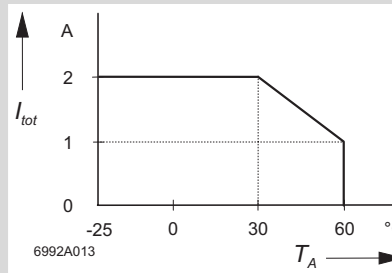

Sensor Supply, Connectors 4 and 5

-25°C to +30°C

2 A

+30°C to +60°C

2 A - ((T_A - 30°C) x 0.033 A/°C)

Approvals

For the latest approvals, please visit www.download.phoenixcontact.com.



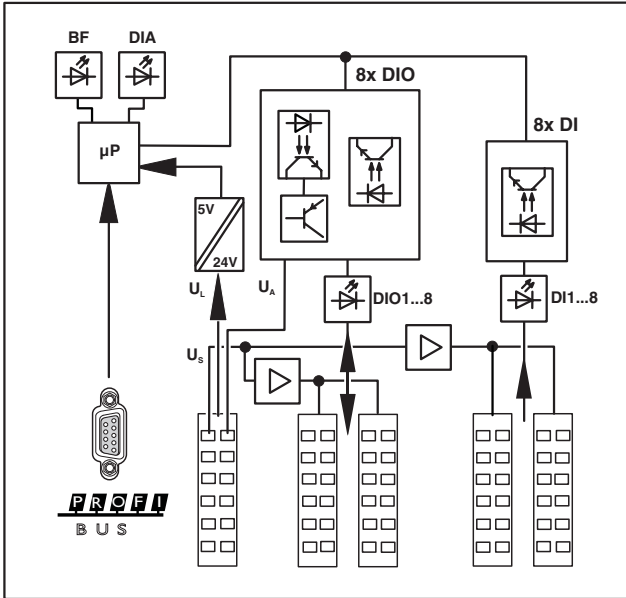



Internal Circuit Diagram



6992B002

Figure 2 Internal wiring of the terminal points

Key:

-  LED
-  Protocol chip (bus logic)
-  Power supply unit with electrical isolation
-  Optocoupler
-  Short-circuit-proof output
-  Short-circuit-proof sensor supply

Local Diagnostic and Status Indicators

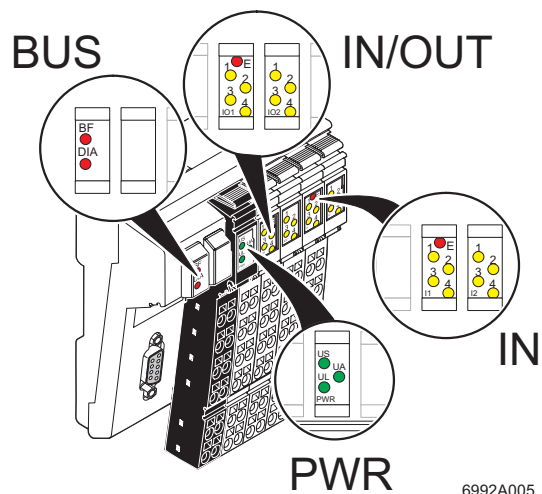

6992A005

Figure 3 Diagnostic and status indicators of the ILB PB 24 DI8 DIO8 (/CN) module

Designation	Color	Meaning
PROFIBUS		
BF	Red	No cyclic data exchange via PROFIBUS, synchronization or parameterization running, timeout elapsed or incorrect setting
	OFF	The module is addressed by PROFIBUS and is in the "cyclic process data exchange" state.
DIA	Red	Module diagnostics
PWR		
US	Green	Sensor supply
UL	Green	Communications power
UA	Green	Actuator supply
IN/OUT		
E	Red	Short circuit or error load at one of the outputs
1 - 4	Yellow	Status indicators of the inputs and outputs
IN		
E	Red	Sensor supply overload
1 - 4	Yellow	Status indicators of the inputs



If the error LED (E) of a group of eight outputs lights up (connector 2 and connector 3), this indicates that a short circuit or overload is present at one or more of the outputs in this group.

Address Setting

Addresses are set using two rotary encoding switches. The left switch is used to set the position in tens and the right switch is used to set the position in units. Addresses can be set between 1 and 99. Figure 4 shows how to set the address "74".

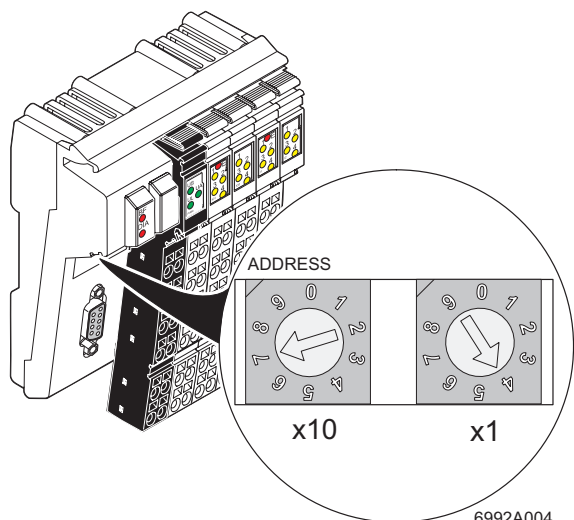

Figure 4 PROFIBUS rotary encoding switches



Any change to an address setting is only accepted after a voltage reset.

Connecting PROFIBUS, the Supply, Actuators, and Sensors

Connecting PROFIBUS

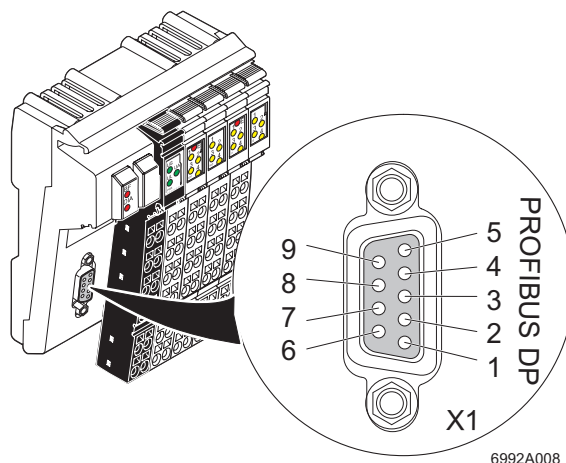

Figure 5 Pin assignment of the 9-pos. D-SUB female connector

Connect PROFIBUS to the module using a 9-pos. D-SUB connector (e.g., SUBCON-PLUS-PROFIB). For the pin assignment, please refer to the following table:

Pin	Assignment
1	Reserved
2	Reserved
3	RxD/TxD-P (receive/transmit data +), cable B
4	CNTR-P (control signal for repeater), direction control
5	DGND (reference potential to +5 V)
6	VP (supply voltage +5 V for termination resistors)
7	Reserved
8	RxD/TxD-N (receive/transmit data -), cable A
9	Reserved

Connecting the Supply, Actuators, and Sensors

Module Versions ILB PB 24 DI8 DIO8 and ILB PB 24 DI8 DIO8/CN

Terminal Point Assignment of the Power Connector (Connector 1 in Figure 6)

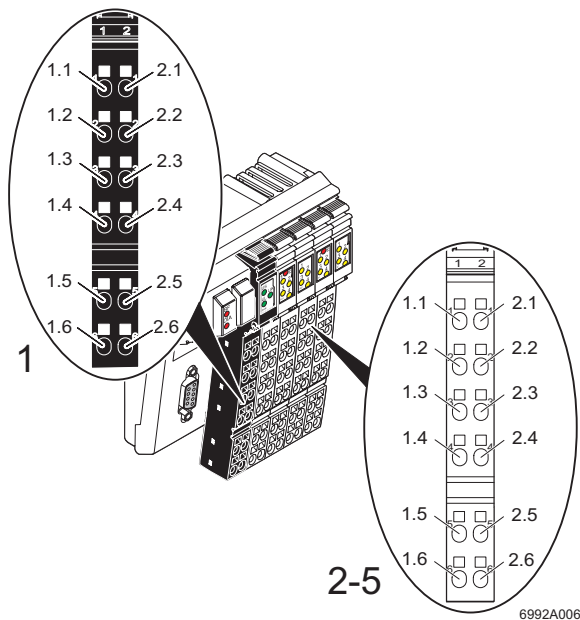

Figure 6 Terminal point assignment of Inline connectors (module version ILB PB 24 DI8 DIO8 as an example)

Terminal Point	Assignment
Connector 1 (PWR)	
1.1	24 V sensor supply U_S
1.2	24 V communications power U_L
1.3	GND
1.4	FE
1.5	24 V communications power U_L
1.6	GND
2.1	Actuator supply U_A
2.2	24 V communications power U_L
2.3	GND
2.4	FE
2.5	24 V communications power U_L
2.6	GND



The terminal points can have a total current of 8 A per terminal point. The maximum current carrying capacity of 8 A must not be exceeded. If the total output current in your application is > 8 A, supply the module via a minimum of two terminal points connected in parallel.



The supply points have the same ground potential. All ground supplies on a module are electrically connected with one another. The communications power is also electrically connected via all contacts. In this way, it can supply all potentials with just one supply without the need for additional terminals, see "Connection example" on page 13.

Differences in the Labeling of Input and Output Connectors

The labeling of **input** and **output** connectors depends on the module version used.

Labeling of Input and Output Connectors for Module Version ILB PB 24 DI8 DIO8

IN/OUT				IN			
Connector 2		Connector 3		Connector 4		Connector 5	
1.1	2.1	1.1	2.1	1.1	2.1	1.1	2.1
1.2	2.2	1.2	2.2	1.2	2.2	1.2	2.2
1.3	2.3	1.3	2.3	1.3	2.3	1.3	2.3
1.4	2.4	1.4	2.4	1.4	2.4	1.4	2.4
1.5	2.5	1.5	2.5	1.5	2.5	1.5	2.5
1.6	2.6	1.6	2.6	1.6	2.6	1.6	2.6

The terminal points of connectors 2 to 5 have **identical** numbering (from 1.1 to 2.6 respectively)

Labeling of Input and Output Connectors for Module Version ILB PB 24 DI8 DIO8/CN

IN/OUT				IN			
Connector 2		Connector 3		Connector 4		Connector 5	
1.1	2.1	3.1	4.1	1.1	2.1	3.1	4.1
1.2	2.2	3.2	4.2	1.2	2.2	3.2	4.2
1.3	2.3	3.3	4.3	1.3	2.3	3.3	4.3
1.4	2.4	3.4	4.4	1.4	2.4	3.4	4.4
1.5	2.5	3.5	4.5	1.5	2.5	3.5	4.5
1.6	2.6	3.6	4.6	1.6	2.6	3.6	4.6

The terminal points of connectors 2 and 3, and 4 and 5 have **continuous** numbering (from 1.1 to 4.6 respectively).

Module Version ILB PB 24 DI8 DIO8

Terminal Point Assignment of Input or Output Connectors (Connectors 2 and 3 in Figure 6 on Page 10)

Terminal Point		Assignment
Connector 2 (IO1)	Connector 3 (IO2)	
1.1, 2.1	1.1, 2.1	Signal input (IN) or signal output (OUT)
1.2, 2.2	1.2, 2.2	Sensor voltage U_S for 2 and 3-wire termination
1.3, 2.3	1.3, 2.3	Ground contact (GND) for 3-wire termination
1.4, 2.4	1.4, 2.4	Signal input (IN) or signal output (OUT)
1.5, 2.5	1.5, 2.5	Sensor voltage U_S for 2 and 3-wire termination
1.6, 2.6	1.6, 2.6	Ground contact (GND) for 3-wire termination

Terminal Point Assignment of Input Connectors (Connectors 4 and 5 in Figure 6 on Page 10)

Terminal Point		Assignment
Connector 4 (I1)	Connector 5 (I2)	
1.1, 2.1	1.1, 2.1	Signal input (IN)
1.2, 2.2	1.2, 2.2	Sensor voltage U_S for 2 and 3-wire termination
1.3, 2.3	1.3, 2.3	Ground contact (GND) for 3-wire termination
1.4, 2.4	1.4, 2.4	Signal input (IN)
1.5, 2.5	1.5, 2.5	Sensor voltage U_S for 2 and 3-wire termination
1.6, 2.6	1.6, 2.6	Ground contact (GND) for 3-wire termination

Module Version ILB PB 24 DI8 DIO 8/CN

Terminal Point Assignment of Input or Output Connectors (Connectors 2 and 3 in Figure 6 on Page 10)

Terminal Point		Assignment
Connector 2 (IO1)	Connector 3 (IO2)	
1.1, 2.1	3.1, 4.1	Signal input (IN) or signal output (OUT)
1.2, 2.2	3.2, 4.2	Sensor voltage U_S for 2 and 3-wire termination
1.3, 2.3	3.3, 4.3	Ground contact (GND) for 3-wire termination
1.4, 2.4	3.4, 4.4	Signal input (IN) or signal output (OUT)
1.5, 2.5	3.5, 4.5	Sensor voltage U_S for 2 and 3-wire termination
1.6, 2.6	3.6, 4.6	Ground contact (GND) for 3-wire termination

Terminal Point Assignment of Input Connectors (Connectors 4 and 5 in Figure 6 on Page 10)

Terminal Point		Assignment
Connector 4 (I1)	Connector 5 (I2)	
1.1, 2.1	3.1, 4.1	Signal input (IN)
1.2, 2.2	3.2, 4.2	Sensor voltage U_S for 2 and 3-wire termination
1.3, 2.3	3.3, 4.3	Ground contact (GND) for 3-wire termination
1.4, 2.4	3.4, 4.4	Signal input (IN)
1.5, 2.5	3.5, 4.5	Sensor voltage U_S for 2 and 3-wire termination
1.6, 2.6	3.6, 4.6	Ground contact (GND) for 3-wire termination

Module Versions ILB PB 24 DI8 DIO8 and ILB PB 24 DI8 DIO8/CN



Each individual channel on the connectors 2 and 3 can be used as an input or output. A configuration is not required.



If a channel is used as an input, this input must **not** be set as an output.

Connection Example

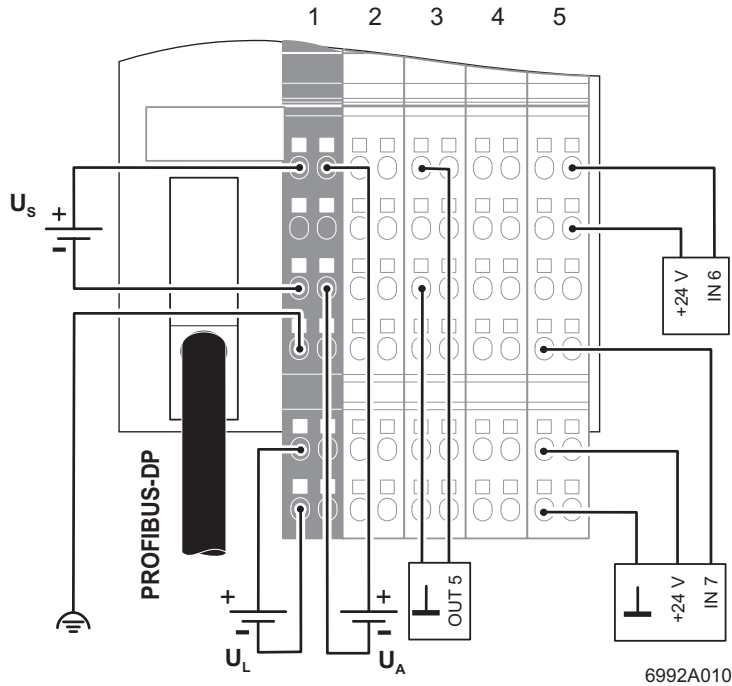

6992A010

Figure 7 Connection example



The numbers above the module illustration identify the connector slots.



When connecting the sensors and actuators, observe the assignment of the terminal points to the process data (see "Process Data" on page 14).



The module has an FE spring (metal clip) on the bottom of the electronics base. This spring creates an electrical connection to the DIN rail. Use grounding terminals to connect the DIN rail to protective earth ground. The module is grounded when it is snapped onto the DIN rail.
To ensure reliable functional earth grounding of the module even when the DIN rail is dirty or the metal clip is damaged, Phoenix Contact also recommends grounding the module via one of the FE terminal points.

Device Data

ID number	06BD
Input address area	2 bytes
Output address area	1 byte

Process Data



The current GSD file can be downloaded at www.download.phoenixcontact.com.

Module Version ILB PB 24 DI8 DIO8

Assignment of the Terminal Points to the OUT Process Data Word (Slots 2 and 3)

(Word.bit) view	Word	Word 0															
	Bit	15	14	13	12	11	10	9	8	7	6	5	4	3	2	1	0
(Byte.bit) view	Byte	Byte 0								Byte 1							
	Bit	7	6	5	4	3	2	1	0	7	6	5	4	3	2	1	0
Module	Slot	3 (IO2)				2 (IO1)											
	Terminal point (signal)	2.4	1.4	2.1	1.1	2.4	1.4	2.1	1.1								
	Terminal point (GND)	2.6	1.6	2.3	1.3	2.6	1.6	2.3	1.3								
Status indicator	Slot	3 (IO2)				2 (IO1)											
	LED	4	3	2	1	4	3	2	1								

Assignment of Terminal Points to the IN Process Data Word (Slots 2 to 5)

(Word.bit) view	Word	Word 0															
	Bit	15	14	13	12	11	10	9	8	7	6	5	4	3	2	1	0
(Byte.bit) view	Byte	Byte 0								Byte 1							
	Bit	7	6	5	4	3	2	1	0	7	6	5	4	3	2	1	0
Module	Slot	3 (IO2)				2 (IO1)				5 (I2)				4 (I1)			
	Terminal point (signal)	2.4	1.4	2.1	1.1	2.4	1.4	2.1	1.1	2.4	1.4	2.1	1.1	2.4	1.4	2.1	1.1
	Terminal point (24 V)	2.5	1.5	2.2	1.2	2.5	1.5	2.2	1.2	2.5	1.5	2.2	1.2	2.5	1.5	2.2	1.2
	Terminal point (GND)	2.6	1.6	2.3	1.3	2.6	1.6	2.3	1.3	2.6	1.6	2.3	1.3	2.6	1.6	2.3	1.3
Status indicator	Slot	3 (IO2)				2 (IO1)				5 (I2)				4 (I1)			
	LED	4	3	2	1	4	3	2	1	4	3	2	1	4	3	2	1

Module Version ILB PB 24 DI8 DIO8/CN

Assignment of Terminal Points to the OUT Process Data Word (Slots 2 and 3)

(Word.bit) view	Word	Word 0															
	Bit	15	14	13	12	11	10	9	8	7	6	5	4	3	2	1	0
(Byte.bit) view	Byte	Byte 0								Byte 1							
	Bit	7	6	5	4	3	2	1	0	7	6	5	4	3	2	1	0
Module	Slot	3 (IO2)				2 (IO1)											
	Terminal point (signal)	4.4	3.4	4.1	3.1	2.4	1.4	2.1	1.1								
	Terminal point (GND)	4.6	3.6	4.3	3.3	2.6	1.6	2.3	1.3								
Status indicator	Slot	3 (IO2)				2 (IO1)											
	LED	4	3	2	1	4	3	2	1								

Assignment of Terminal Points to the IN Process Data Word (Slot 2 to 5)

(Word.bit) view	Word	Word 0															
	Bit	15	14	13	12	11	10	9	8	7	6	5	4	3	2	1	0
(Byte.bit) view	Byte	Byte 0								Byte 1							
	Bit	7	6	5	4	3	2	1	0	7	6	5	4	3	2	1	0
Module	Slot	3 (IO2)				2 (IO1)				5 (I2)				4 (I1)			
	Terminal point (signal)	4.4	3.4	4.1	3.1	2.4	1.4	2.1	1.1	4.4	3.4	2.1	1.1	4.4	3.4	2.1	1.1
	Terminal point (24 V)	4.5	3.5	4.2	3.2	2.5	1.5	2.2	1.2	4.5	3.5	2.2	1.2	4.5	3.5	2.2	1.2
	Terminal point (GND)	4.6	3.6	4.3	3.3	2.6	1.6	2.3	1.3	4.6	3.6	2.3	1.3	4.6	3.6	2.3	1.3
Status indicator	Slot	3 (IO2)				2 (IO1)				5 (I2)				4 (I1)			
	LED	4	3	2	1	4	3	2	1	4	3	2	1	4	3	2	1

Diagnostic Data

Mapping of Diagnostic Data in PROFIBUS

Diagnostic Data	Bit 7	Bit 6	Bit 5	Bit 4	Bit 3	Bit 2	Bit 1	Bit 0	Remark
Byte 0	X	X	X	X	X	X	X	X	Station status 1
Byte 1	X	X	X	X	X	X	X	X	Station status 2
Byte 2	X	X	X	X	X	X	X	X	Station status 3
Byte 3	X	X	X	X	X	X	X	X	Master address diagnostics
Byte 4	0	0	0	0	0	1	1	0	High ID number
Byte 5	1	0	1	1	1	1	0	1	Low ID number
Byte 6	0	0	0	0	0	1	1	1	Diagnostic header
Byte 7	M.7	M.6	M.5	M.4	M.3	M.2	M.1	M.0	Device diagnostics
Byte 8	0	0	0	0	0	0	0	0	Reserved
Byte 9	0	0	0	0	0	0	0	0	Reserved
Byte 10	0	0	0	0	0	0	0	0	Reserved
Byte 11	0	0	0	0	0	0	0	0	Reserved
Byte 12	X	X	0	0	0	0	0	0	Reserved



Bytes 0 to 6 are PROFIBUS standard. Bytes 7 to 12 are device-specific.

Diagnostic Data for Device Diagnostics

Bit	Remark	Assignment
M.0	Short circuit/overload status of at least one output	1, if output is overloaded/short circuited
M.1	Overload status of a sensor supply	1, if sensor supply is overloaded
M.2	Sensor supply U_S status	1, if U_S is too low
M.3 - M.7	Reserved	0



If a diagnostic event occurs, the diagnostic data is always sent to the master by means of a diagnostic telegram generated once by the device.
The current status of the diagnostic data can be read by the device at any time.

Error Table With Diagnostic Data and Status Indicators

Error Type	Diagnostic Data	Status Indicators
Sensor voltage U_S too low	Diagnostic register bit 2 is set to "1"	US (PWR) LED is off DIA LED is red
Actuator supply U_A too low	No response	UA LED is off
Short circuit of a sensor supply	Diagnostic register bit 1 is set to "1"	E (IN) LED of the sensor supply is red DIA LED is red
Short circuit of a digital output	Diagnostic register bit 0 is set to "1"	E (OUT) LED of the affected output group is red DIA LED is red

© PHOENIX CONTACT 03/2007



SCATTERGOOD & JOHNSON LTD

ELECTRICAL ENGINEERING & FLUID CONTROL DISTRIBUTORS

Est.1899

At Scattergood & Johnson Ltd, we pride ourselves on being a technical distributor to specialist industries.

Working with a range of quality product suppliers across a number of specialist markets, we are not your average 'box shifter' - we are your technical and supply chain partner.

We fully support every product we sell - for free! Our internal team and external sales engineers can answer any product or application question, no matter the complexity.

Backing up this technical ability is a range of 50,000+ products available from stock for nationwide next day delivery (same day if required!), or you can collect what you need from any of our trade counters around the UK.

Select your specialist interest below to learn more about how we can help.



Online, In Branch and On the Road - Scattergood & Johnson Ltd, there when you need us.

www.scatts.co.uk