

IB IL TEMP 4/8 RTD ...

**Inline analog input terminal,
8 channels, RTDs,
2 and 3-wire connection method**

AUTOMATION

Data sheet
7079_en_05

© PHOENIX CONTACT 2011-03-17

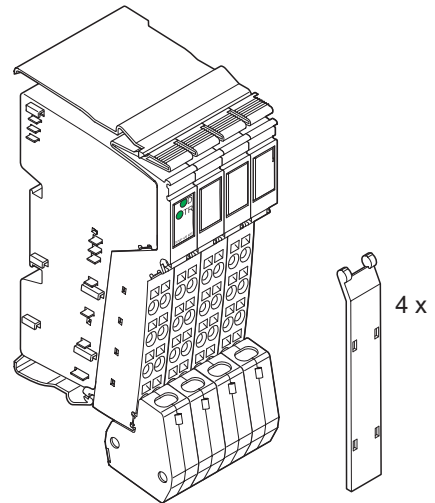

1 Function description

The terminal is designed for use within an Inline station. This terminal provides an 8-channel input module for resistance temperature detectors (RTDs).

There are two options for data exchange:

- Via process data (**four** inputs each in one bus cycle, multiplex mode)
- Via PCP (all **eight** inputs in the "Analog Values" PCP object)

This terminal supports:

- Platinum and nickel sensors, e.g., Pt100, Pt1000, Ni1000 according to standard DIN EN 60751 and the SAMA guideline, as well as various other sensors
- KTY81 and KTY84 sensors
- The sensor type Pt10000 especially for building automation

The measuring temperature is represented by standardized 16-bit values.

Features

- Eight inputs for resistive temperature sensors and linear resistors up to 20 k Ω .
- Connection of sensors in 2 and 3-wire technology
- Communication via either process data or parameter channel (PCP)
- Channels are configured independently of one another using the bus system.
- Robust inputs, ideal for the use in harsh industrial environments with high electromagnetic interference
- Diagnostic indicators
- Temperature and resistance measurement in the range of milliseconds



This data sheet is only valid in association with the IL SYS INST UM E user manual.



Make sure you always use the latest documentation.
It can be downloaded at www.phoenixcontact.net/catalog.



Function blocks are available to aid use of this terminal.
They can be downloaded at www.phoenixcontact.net/catalog.



This data sheet is valid for all products listed on the following page:

Table of contents

1	Function description	1
2	Ordering data.....	3
3	Technical data	4
4	Internal basic circuit diagram	7
5	Local diagnostic and status indicators and terminal point assignment.....	8
6	Safety note.....	9
7	Installation instructions	9
8	Electrical isolation.....	9
9	Connection notes.....	9
10	Connection example.....	9
11	Programming data/configuration data.....	10
12	Process data.....	10
13	OUT process data words	10
14	IN process data words	13
15	Formats for representing measured values.....	15
16	PCP communication	18
17	Configuration and analog values.....	21
18	Measuring ranges.....	22
19	Measuring errors.....	23
20	General notes and recommendations for the signal/noise ratio	25
21	Step response	26

2 Ordering data

Terminal blocks

Description	Type	Order No.	Pcs. / Pkt.
Inline analog input terminal, complete with accessories (connectors and labeling fields), 8 channels, RTDs, 2 and 3-wire connection method, transmission speed of 500 kbps, terminal points of connectors numbered individually	IB IL TEMP 4/8 RTD-PAC	2863915	1
Inline analog input terminal, complete with accessories (connectors and labeling fields), 8 channels, RTDs, 2 and 3-wire connection method, transmission speed of 500 kbps, terminal points of connectors numbered continuously	IB IL TEMP 4/8 RTD-PAC/CN	2692487	1
Inline analog input terminal, complete with accessories (connectors and labeling fields), 8 channels, RTDs, 2 and 3-wire connection method, transmission speed of 2 Mbps, terminal points of connectors numbered individually	IB IL TEMP 4/8 RTD-2MBD-PAC	2878612	1
Inline analog input terminal, without accessories, 8 channels, RTDs, 2 and 3-wire connection method, transmission speed of 500 kbps	IB IL TEMP 4/8 RTD	2863009	1
Inline analog input terminal, without accessories, 8 channels, RTDs, 2 and 3-wire connection method, transmission speed of 2 Mbps	IB IL TEMP 4/8 RTD-2MBD	2862916	1



You need 4 connectors with shield connector for the IB IL TEMP 4/8 RTD and IB IL TEMP 4/8 RTD-2MBD terminals.

Accessories

Description	Type	Order No.	Pcs. / Pkt.
Connector with shield connection	IB IL SCN-6 SHIELD-TWIN	2740245	5
Shield connection clamp for applying the shield on busbars, 8 mm diameter	SK8	3025163	10
Shield connection clamp for applying the shield on busbars, 14 mm diameter	SK14	3025176	10
Shield connection clamp for applying the shield on busbars, 20 mm diameter	SK20	3025189	10
Shield connection clamp for applying the shield on busbars, 35 mm diameter	SK35	3026463	10
Support for assembly on DIN rails for 10 mm x 3 mm busbars	AB-SK	3025341	10
Support for direct mounting with contact to the mounting surface	AB-SK 65	3026489	10
Support, made of insulation material, with fixing screws, can be used for either 10 mm x 3 mm or 6 mm x 6 mm busbars	AB-SK/E	3026476	10
N busbar, 10 mm x 3 mm, 1 m long	NLS-CU 3/10	0402174	1
End terminal, 4 mm ² , without insulating cap	AK 4	0404017	50
End terminal, 4 mm ² , with insulating cap, green-yellow for PE	AK G GNYE	0421029	50
End terminal, 4 mm ² , with insulating cap, black for L1, L2, L3	AKG 4 BK	0421032	50

Documentation

Description	Type	Order No.	Pcs. / Pkt.
"Automation terminals of the Inline product range" user manual	IL SYS INST UM E	-	-
"Peripherals Communication Protocol (PCP)" user manual	IBS SYS PCP G4 UM E	2745169	1
"Porting using PCP compact" user manual	IBS PCP COMPACT UM E	9015349	1

3 Technical data

General data

Housing dimensions (width x height x depth)	48.8 mm x 136.8 mm x 71.5 mm (with connectors)
Weight	125 g (without connectors), 190 g (with connectors)
Operating mode	Process data mode with 5 words/1 word PCP
Connection method for sensors	2 and 3-wire technology
Ambient temperature (operation)	-25°C ... +55°C
Ambient temperature (storage/transport)	-25°C ... +85°C
Permissible humidity (operation/storage/transport)	10% ... 95%, according to DIN EN 61131-2
Permissible air pressure (operation/storage/transport)	70 kPa ... 106 kPa (up to 3000 m above sea level)
Degree of protection	IP20
Class of protection	Class III, EN 61131-2, IEC 61131-2
Connection data for Inline connectors	
Connection method	Spring-cage terminal blocks
Conductor cross section	0.08 mm ² ... 1.5 mm ² (solid or stranded), 28 - 16 AWG

Interface

Inline local bus	Inline data routing
------------------	---------------------

Transmission speed

IB IL TEMP 4/8 RTD, IB IL TEMP 4/8 RTD-PAC, IB IL TEMP 4/8 RTD-PAC/CN	500 kbps
IB IL TEMP 4/8 RTD-2MBD, IB IL TEMP 4/8 RTD-2MBD-PAC	2 Mbps

Power consumption

	500 kbps	2 Mbps
Communications power U_L	7.5 V	7.5 V
Current consumption from U_L	75 mA (typical)	100 mA (typical)
I/O supply voltage U_{ANA}	24 V DC	24 V DC
Current consumption at U_{ANA}	28 mA (typical)	41 mA (typical)
Total power consumption	1.24 W (typical)	1.75 W (typical)

Supply of the module electronics and I/O through bus coupler/power terminal

Connection method	Potential routing
-------------------	-------------------

Analog inputs

Number	8 analog RTD inputs
Description of the input	Input for resistive temperature sensors
Connection method	Spring-cage connection
Connection method	2, 3-wire (shielded)
Linear resistance range	0 Ω ... 400 Ω , 0 Ω ... 20 k Ω
Sensor types that can be used	Pt, Ni, KTY, Cu, linear resistors
Standards for characteristic curves	According to DIN EN 60751: 07/1996/ according to SAMA RC 21-4-1966
Measuring principle	Successive approximation
Measured value representation	16 bits (15 bits + sign bit)
Conversion time of the A/D converter	5 μ s, typical; 10 μ s, maximum
Process data update	6 ms (up to 230 ms possible depending on the connection method)
Data formats	IB IL, IB ST, S7-compatible
Accuracy	0.06% (typical), 0.25% (maximum)
Accuracy	$\pm 0.5^\circ\text{C}$ (typical)

Additional tolerances influenced by electromagnetic fields

Type of electromagnetic interference	Typical deviation of the measuring range final value	
	Relative for the input area linear R 0 to 400 Ω	Relative for the input area linear R 0 to 20 kΩ
Electromagnetic fields; field strength 10 V/m according to EN 61000-4-3/IEC 61000-4-3	< ±4.8%	< ±0.5%
Conducted interference Class 3 (test voltage 10 V) according to EN 61000-4-6/IEC 61000-4-6	< ±3.5%	< ±0.3%

Tolerances at T_A = +25°C

Sensor type	Range		T _A = +25°C		T _A = +25°C	
	Lower limit	Upper limit	Absolute deviation		Relative deviation	
			Typical	Maximum	Typical	Maximum
Pt100DIN and SAMA (3-wire connection)	-200°C	+850°C	±0.50°C	±2.13°C	±0.06%	±0.25%
Pt100DIN and SAMA (2-wire connection)	-200°C	+850°C	±1.22°C	±5.64°C	±0.14%	±0.66%
Pt10000 DIN and SAMA (2 and 3-wire connection)	0°C	+70°C	±0.60°C	±1.80°C	±0.86%	±2.57%
Pt10000 DIN and SAMA (2 and 3-wire connection)	-200°C	+180°C	±1.24°C	±3.10°C	±0.69%	±1.72%
Rlin400 (3-wire termination)	0 Ω	400 Ω	±0.20 Ω	±0.83 Ω	±0.05%	±0.21%
Rlin400 (2-wire termination)	0 Ω	400 Ω	±0.48 Ω	±2.20 Ω	±0.12%	±0.55%
Rlin20k (2 and 3-wire termination)	0 Ω	20000 Ω	±150 Ω	±200 Ω	±0.75%	±1.00%

The data contains the offset error, gain error, and linearity error in its respective basic setting. The data is related to nominal operation (preferred mounting position, U_S = 24 V) with pre-set 32-sample filter. Please also observe the values for temperature drift and the tolerances under EMI.

All errors indicated as a percentage are related to the positive measuring range final value.

The **maximum** tolerance values represent the worst case measurement inaccuracy. They contain the theoretically maximum possible tolerances in the corresponding measuring ranges. In the same way, the theoretical maximum possible tolerances of the calibration and test equipment have been taken into account. This data is valid for at least twelve months.

Temperature and drift response

Sensor type	Range		T _A = -25°C to +55°C	
	Lower limit	Upper limit	Drift (related to the measuring range final value)	
			Typical	Maximum
Pt100 DIN and SAMA	-200°C	+850°C	60 ppm/K	220 ppm/K
Pt1000 DIN and SAMA	-200°C	+850°C	150 ppm/K	500 ppm/K
Pt10000 DIN and SAMA	-200°C	+180°C	390 ppm/K	1200 ppm/K
Rlin400	0 Ω	400 Ω	60 ppm/K	250 ppm/K
Rlin20k	0 Ω	20000 Ω	280 ppm/K	900 ppm/K

Protective equipment

Short-circuit protection for each input

Yes

Electrical isolation**Common potentials**

The 24 V main voltage U_M , 24 V segment voltage U_S , and GND have the same potential. FE is a separate potential area.

Separate potentials in the IB IL TEMP 4/8 RTD terminal**Test distance**

7.5 V supply (bus logic)/
±15 V, ±5 V analog supply (analog I/O)

7.5 V supply (bus logic)/functional earth ground

±15 V, ±5 V analog supply (analog I/O)/functional earth ground

Test voltage

500 V AC, 50 Hz, 1 min.

500 V AC, 50 Hz, 1 min.

500 V AC, 50 Hz, 1 min.

Error messages to the higher-level control or computer system

Failure of the internal I/O voltage supply

Yes, I/O error message sent to the bus coupler

Failure of or insufficient communications power U_L

Yes, I/O error message sent to the bus coupler

Error messages via process data

Peripheral fault/user error

Yes (see page 15)

Mechanical requirements

Vibration, IEC 60068-2-6; EN 60068-2-6

5g

Shock, IEC 60068-2-27; EN 60068-2-27

30g

Approvals

For the latest approvals, please visit www.phoenixcontact.net/catalog.

4 Internal basic circuit diagram

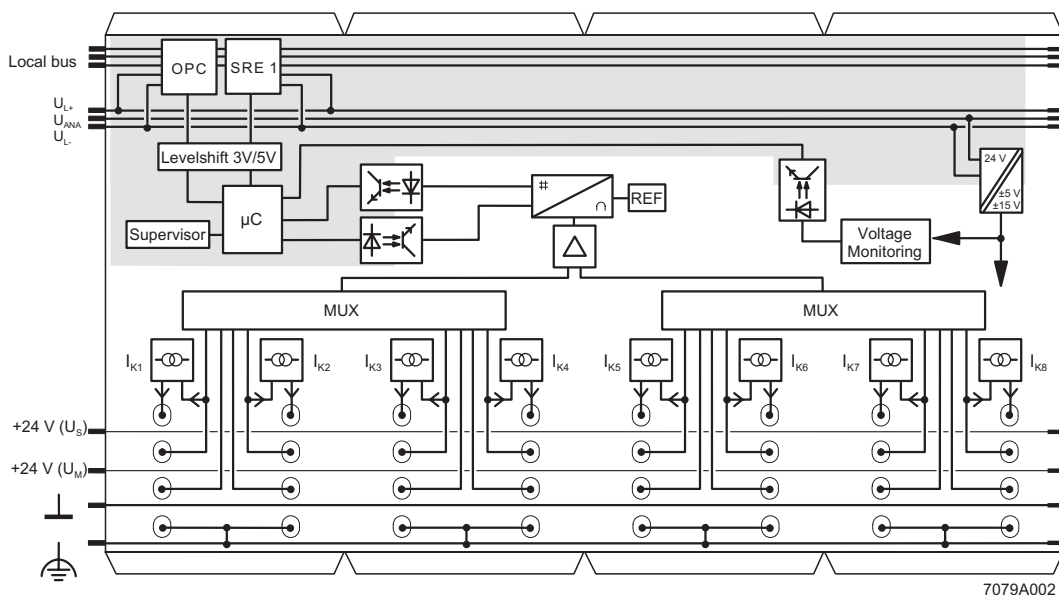













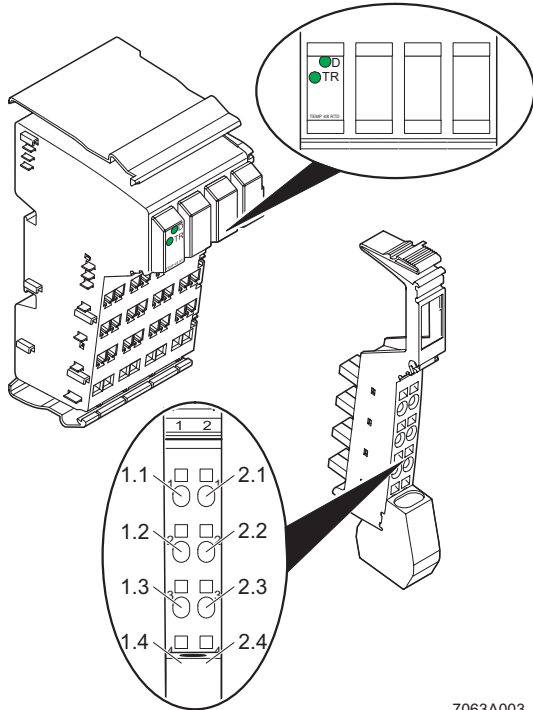

Figure 1 Internal wiring of the terminal points

Key:

	Protocol chip		Amplifier
	Register expansion		Voltage monitoring
	Level adaptation		DC/DC converter with electrical isolation
	Hardware monitoring		Multiplexer
	Microcontroller		Constant current source
	Optocoupler	 Other symbols used are explained in the IL SYS INST UM E user manual.	
	Analog/digital converter		
	Reference voltage		

5 Local diagnostic and status indicators and terminal point assignment



7063A003

Figure 2 IB IL TEMP 4/8 RTD with an appropriate connector

Function identification

Green

2 Mbps: white stripe in the vicinity of the D LED

5.1 Local diagnostic and status indicators

Des.	Color	Meaning
D	Green	Diagnostics
TR	Green	PCP active

5.2 Terminal point assignment for 2-wire connection

Terminal points	Signal	Assignment
X.1	I_1+/U_1+	RTD sensor 1 I: Constant current supply U: Measuring input
X.2	I_1-/U_1-	
X.3	-	-
X.1	I_2+/U_2+	RTD sensor 2 I: Constant current supply U: Measuring input
X.2	I_2-/U_2-	
X.3	-	-
X.4, 2.4	-	FE

5.3 Terminal point assignment for 3-wire connection

Terminal points	Signal	Assignment
X.1	I_1+/U_1+	RTD sensor 1
X.2	I_1-	Constant current supply
X.3	U_1-	Measuring input sensor 1
X.1	I_2+/U_2+	RTD sensor 2
X.2	I_2-	Constant current supply
X.3	U_2-	Measuring input sensor 2
X.4, X.4	-	FE

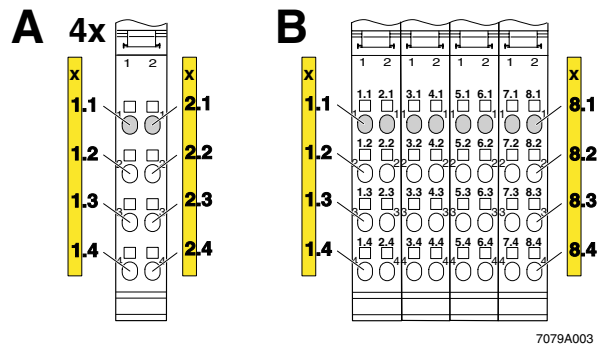

7079A003

Figure 3 Terminal point numbering: individual connectors (A) and connector sets (B)

- A) Using the IB IL TEMP 4/8 RTD-PAC and IB IL TEMP 4/8 RTD-2MBD-PAC with the connectors provided.
Using IB IL SCN-6 SHIELD-TWIN individual connectors
- B) Using the IB IL TEMP 4/8 RTD-PAC/CN terminal with the provided connectors

6 Safety note



During configuration, ensure that no isolating voltage for safe isolation is specified between the analog inputs and the bus. During thermistor detection, for example, this means that the user has to provide signals with **safe isolation**, if applicable.

7 Installation instructions

High current flowing through potential jumpers U_M and U_S leads to a temperature rise in the potential jumpers and inside the terminal. To keep the current flowing through the potential jumpers of the analog terminals as low as possible, always place the analog terminals after all the other terminals at the end of the main circuit (for the sequence of the In-line terminals, see also IL SYS INST UM E user manual).

8 Electrical isolation

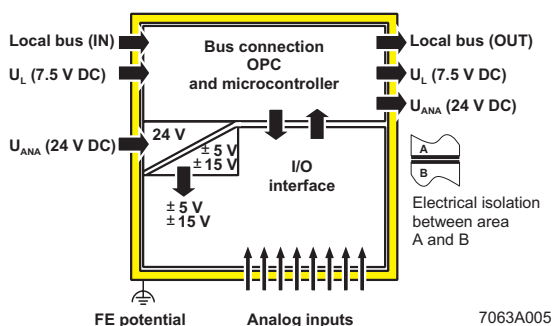

Figure 4 Electrical isolation of the individual function areas

9 Connection notes

Connecting the resistance temperature detectors

Always connect temperature shunts using shielded, twisted-pair cables.

Connecting the shield

The connection examples show how to connect the shield (Figure 5).

Insulate the shield at the sensor.

Unused channels

Short-circuit unused channels (see Figure 5 on page 9, channels 2 to 7).

This ensures that the measuring values at the other channels are within the specified tolerances.

10 Connection example



When connecting the shield before the terminal, insulate the shield on the sensor side (shown in gray in Figure 5). Figure 5 shows the connection schematically.

Connection of passive sensors

Slot	1	2	3	4
Channel	1 2	3 4	5 6	7 8

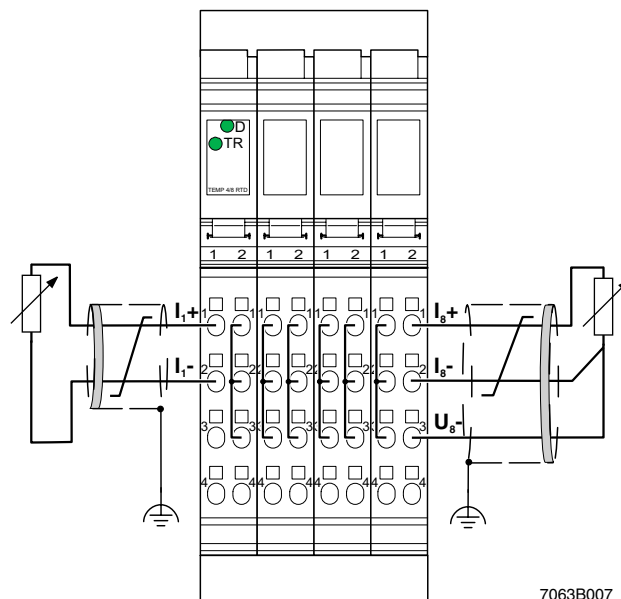

Figure 5 Connection of sensors in 2 and 3-wire technology with shield connection

Channel 1: 2-wire technology; channel 8: 3-wire technology
Other channels: not used (with short-circuit jumpers)

11 Programming data/configuration data

INTERBUS (local bus)

ID code	DF _{hex} (223 _{dec})
Length code	05 _{hex}
Process data channel	80 bits
Input address area	5 words
Output address area	5 words
Parameter channel (PCP)	1 word
Register length (bus)	6 words

Other bus systems



For the programming data/configuration data of other bus systems, please refer to the corresponding electronic device data sheet (e.g., GSD, EDS).

12 Process data

The terminal has five process data words and one PCP word.

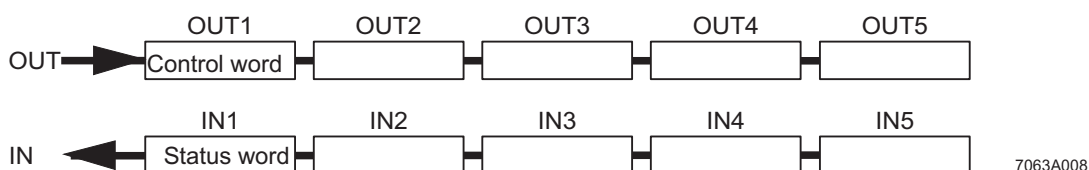

Figure 6 Order of the process data words

13 OUT process data words

Five process data output words are available.

Configure the terminal channels via the OUT process data words OUT1 and OUT2. In this context, the output word OUT1 contains the command and the output word OUT2 contains the parameters belonging to this command.

The following configurations are possible:

Configuration	Short designation	Default
Selection of mean-value generation (filtering)	Filter	16-sample mean value
Type of sensor connection	Connection	3-wire technology
Value of reference resistance R_0	R_0	100 Ω
Resolution setting	Resolution	0.1 °C
Selection of the format for representing measured values	Format	IBIL format
Sensor type setting	Sensor type	Pt100 (DIN)

Configuration errors are indicated in the status word. The configuration settings are stored in a volatile memory.

If you change the configuration, the message "Measured value invalid" appears (diagnostic code 8004_{hex}), until new measured values are available.



Please note that extended diagnostics is only possible if the IB IL format is configured as the format for representing the measured values. As this format is preset on the terminal, it is available as soon as the voltage is applied.

13.1 Output word OUT1 (control word)

		OUT1															
Bit		15	14	13	12	11	10	9	8	7	6	5	4	3	2	1	0
Assignment		Command code								0	0	0	0	0	0	0	0

Bit 15 to bit 8 (command code):

Bit 15 to bit 8	OUT1	Command function
0 0 0 0 0 C C C	0x00 _{hex}	Read measured value in IN2 channel-by-channel.
0 0 0 0 1 0 0 0	0800 _{hex}	Read measured values of channels 1 to 4 in IN2 to IN5.
0 0 0 0 1 0 0 1	0900 _{hex}	Read measured values of channel 5 to 8 into IN2 to IN5.
0 0 0 0 1 0 1 0	0A00 _{hex}	Read measured values of channels 1 to 4 in IN2 to IN5. Conversion of these channels only (shorter conversion time)
0 0 0 1 0 C C C	1x00 _{hex}	Read configuration in IN2 channel-by-channel.
0 0 1 1 1 1 0 0	3C00 _{hex}	Read firmware version and module ID in IN2.
0 1 0 0 0 C C C	4x00 _{hex}	Configure channel, configuration in OUT2
0 1 0 1 0 C C C	5x00 _{hex}	Configure channel and read measured value of the channel, configuration in OUT2, measured value in IN2.
0 1 1 0 0 0 0 0	6000 _{hex}	Configure entire terminal (all channels); configuration in OUT2.

CCC = channel number

13.2 Output word OUT2 (parameter word)

The parameters for the commands 4x00_{hex}, 5x00_{hex}, and 6000_{hex} must be specified in OUT2. This parameter word is only evaluated for these commands.

		OUT2																
Bit		15	14	13	12	11	10	9	8	7	6	5	4	3	2	1	0	
Assignment		0	Filter			2/3		R ₀				Resolution		Format		Sensor type		

Filter Selects mean value generation. After every conversion, the measured value is saved in a mean value memory via which the mean value is generated. The memory size can be selected with the filter option. E.g., for a 16-sample mean value, the mean value is generated using the last 16 measured values.

2/3 Connection method, 2-wire or 3-wire

R₀ Selection of sensor resistance at 0°C. Here, for example, you can select whether Pt100, Pt500, Pt1000 or Pt10000 are to be used for the platinum sensor type.

Resolution Quantization of the measured value, choice between °Celsius or °Fahrenheit

Format Represents the measured value in the IN process data

Sensor type Sets the selected sensor type



If invalid parameters are specified in the parameter word, the command will not be executed. The command is acknowledged in the input words with the set error bit.

13.3 Parameters for configuration

The values displayed in **bold** are default settings.

Bit 14 and bit 13:

Code		Filter
dec	bin	
0	00	16-sample mean value
1	01	No mean value
2	10	4-sample mean value
3	11	32-sample mean value

Bit 12:

Code		Connection method (2/3)
dec	bin	
0	0	3-wire
1	1	2-wire

Bit 11 to bit 8

Code			R ₀ [Ω]
dec	bin	hex	
0	0000	0	100
1	0001	1	10
2	0010	2	20
3	0011	3	30
4	0100	4	50
5	0101	5	120
6	0110	6	150
7	0111	7	200

Code			R ₀ [Ω]
dec	bin	hex	
8	1000	8	240
9	1001	9	300
10	1010	A	400
11	1011	B	500
12	1100	C	1000
13	1101	D	1500
14	1110	E	2000
15	1111	F	10000

Bit 7 and bit 6:

Code		Resolution for sensor type			
dec	bin	0 to 11	13 (Potentiometer [%])	14 (Linear R: 0 to 400 Ω)	15 (Linear R: 0 to 20000 Ω)
0	00	0.1°C	1%	0.1 Ω	1 Ω
1	01	0.01°C	0.1%	0.01 Ω	0.1 Ω
2	10	0.1°F	Reserved	Reserved	Reserved
3	11	0.01°F			

Bit 5 and bit 4

Code		Format
dec	bin	
0	00	IB IL format (15 bits + sign bit with extended diagnostics)
1	01	IB ST format (12 bits + sign bit + 3 diagnostic bits)
2	10	S7-compatible format (15 bits + sign bit)
3	11	Reserved

Bit 3 to bit 0:

Code		Sensor type
dec	bin	
0	0000	Pt DIN
1	0001	Pt SAMA
2	0010	Ni DIN
3	0011	Ni SAMA
4	0100	Cu10
5	0101	Cu50
6	0110	Cu53
7	0111	Ni1000 (Landis & Gyr)

Code		Sensor type
dec	bin	
8	1000	Ni500 (Viessmann)
9	1001	KTY 81-110
10	1010	KTY 84
11	1011	KTY 81-210
12	1100	Reserved
13	1101	Potentiometer [%]
14	1110	Linear R: 0 to 400 Ω
15	1111	Linear R: 0 to 20000 Ω

Example of a parameterization

Sensor Pt1000 DIN

Bit	OUT2															
	15	14	13	12	11	10	9	8	7	6	5	4	3	2	1	0
Assignment	0	Filter		2/3		R ₀			Resolution		Format		Sensor type			
Assignment	0	1	1	1	1	1	0	0	0	0	0	0	0	0	0	0

14 IN process data words**14.1 Input word IN1 (status word)**

The input word IN1 serves as status word.

Bit	IN1																
	15	14	13	12	11	10	9	8	7	6	5	4	3	2	1	0	
Assignment	EB	Mirrored command code						0	0	0	0	0	0	0	0	0	0

EB: Error bit

EB = 0 No error has occurred.

EB = 1 An error has occurred.

Mirroring of the command code:

A command code mirrored from the control word. Here, the MSB is suppressed.

The following error bits set the error bit during configuration:

- An invalid parameter word was sent.
Remedy: Check the parameters (see "Parameters for configuration" on page 12)
- Parameterization via process data was disabled during parameterization via PCP
Remedy: Permit parameterization via process data ("System bit" element, "Conf" bit = 1, see "Config Table object" on page 19)

14.2 Input words IN2 to IN5

The measured values, the configuration or the firmware version are transmitted to the controller board or the PC using the process data input words IN2 through IN5 in accordance with the configuration.

For the control word **3C00_{hex}**, IN2 supplies the firmware version and the module ID.

Example: firmware version 1.23

		IN2															
Bit		15	14	13	12	11	10	9	8	7	6	5	4	3	2	1	0
Assignment (hex)		1				2				3				E _{hex}			
Meaning		Firmware version 1.23												Module ID			

Basically three formats are available for the representation of the measured values. For more detailed information

about the formats, please refer to "Formats for representing measured values" on page 15.

MSB															LSB	
15	14	13	12	11	10	9	8	7	6	5	4	3	2	1	0	
SB	Analog value														IB IL format, S7-compatible format	

15	14	13	12	11	10	9	8	7	6	5	4	3	2	1	0	
SB	Analog value												0	OC	OR	IB ST format

- MSB Most significant bit
- LSB Least significant bit
- SB Sign bit
- AV Analog value
- 0 Reserved
- OC Open circuit/short circuit
- OR Overrange

Open-circuit detection:

An open circuit is detected according to the following table:

Faulty sensor cable	2-wire	3-wire
I+/U+	Yes	Yes
I-	Yes	Yes
U-	–	No

- Yes Open circuit is detected.
- The cable is not connected when using this connection method.
- No Open circuit is not detected.

15 Formats for representing measured values

15.1 IB IL format (default setting)

The measured value is represented in bits 14 to 0. An additional bit (bit 15) is available as a sign bit. This format supports extended diagnostics. Values > 8000hex and < 8100hex indicate an error.

The following diagnostic codes are possible:

Code (hex)	Error
8001	Measuring range exceeded (overrange)
8002	Open circuit
8004	Measured value invalid/no valid measured value available (e.g., because channel was not configured)
8010	Configuration invalid
8020	I/O supply voltage faulty
8040	Terminal faulty
8080	Below measuring range (underrange)

Measured value representation in IB IL format, 15 bits

MSB														LSB		
15	14	13	12	11	10	9	8	7	6	5	4	3	2	1	0	
SB															Analog value	

SB Sign bit

Typical analog values depending on the resolution

Sensor type		All temperature sensors	Potentiometer	Linear 0 to 400 Ω	Linear 0 to 20 kΩ
Sensor/code		0 to 11	13	14	15
Resolution (bits 7 and 6)		00 _{bin} /10 _{bin}	00 _{bin}	00 _{bin}	00 _{bin}
Process data item (= analog value)		0.1°C/0.1°F [°C]/[°F]	1% [%]	0.1 Ω [Ω]	1 Ω [Ω]
hex	dec				
8002	-	Open circuit	-	-	-
8001	-	Overrange (see table on page 22)	- See note below	>400.0	>20000
2710	10000	1000.0	10000 (100 x R ₀)	-	10000
0FA0	4000	400.0	4000 (40 x R ₀)	400.0	4000
000A	10	1.0	10 (0.10 x R ₀)	1.0	10
0001	1	0.1	1 (0.01 x R ₀)	0.1	1
0000	0	0	0	0	0
FFFF	-1	-0.1	-	-	-
FC18	-1000	-100.0	-	-	-
8080		Underrange (cf. Table page 22)	-	-	-



This sensor type (potentiometer) does not have defined upper limits of the measuring range. Depending on the gain, however, an open circuit is detected at approximately 400 Ω or at approximately 20000 Ω .

Please note for the potentiometer (No. 13) and linear resistor (No. 14 and 15) sensor types that below 0.8% of the nominal range (e.g., 0 Ω to 3 Ω for the "linear R: 0 to 400 Ω " type) the diagnostic messages "Overrange" and "Underrange" can be generated.

Sensor type		All temperature sensors	Potentiometer	Linear 0 to 400 Ω	Linear 0 to 20 k Ω
Sensor/code		0 to 11	13	14	15
Resolution (bits 7 and 6)		01 _{bin} /11 _{bin}	01 _{bin}	01 _{bin}	01 _{bin}
Process data item (= analog value)		0.01°C/0.01°F	0.1%	0.01 Ω	0.1 Ω
hex	dec	[°C]/[°F]	[%]	[Ω]	[Ω]
8002	-	Open circuit	-	-	-
8001	-	> 325.12 Overrange (see page 22)	- 3251.2	325.12	3251.2
2710	10000	100.00	1000.0 (10 x R ₀) -	100.00	1000.0
0FA0	4000	40.00	400.0 (4 x R ₀)	40.00	400.0
000A	10	0.1	1 (0.01 x R ₀)	0.1	1
0001	1	0.01	0.1 (0.001 x R ₀)	0.01	0.1
0000	0	0	0	0	0
FFFF	-1	-0.01	-	-	-
FC18 (-1000)	-10	-10	-	-	-
D8F0	-10000	-100.00	-	-	-
8080		Underrange (see page 22)	-	-	-



If the measured value is outside the representation area of the process data, the "Overrange" or "Underrange" error message is displayed.

Please note for the potentiometer (No. 13) and linear resistor (No. 14 and 15) sensor types that below 0.8% of the nominal range (e.g., 0 Ω to 3 Ω for the "linear R: 0 to 400 Ω " type) the diagnostic messages "Overrange" and "Underrange" can be generated.

15.2 IB ST format

The measured value is represented in bits 14 through 3. The remaining 4 bits are available as sign and error bits.

Measured value representation in IB ST format; 12 bits

MSB											LSB				
15	14	13	12	11	10	9	8	7	6	5	4	3	2	1	0
SB	Analog value											0	OC	OR	

SB	Sign bit
0	Reserved
OC	Open circuit/short circuit
OR	Overrange

Typical analog values depending on the resolution

Sensor type		RTD sensor	
Sensor code		(0 to 11)	
Resolution (bits 7 and 6)		$00_{bin}/10_{bin}$	$01_{bin}/11_{bin}$
Process data item (= analog value)		$0.1^{\circ}\text{C}/0.1^{\circ}\text{F}$	$0.01^{\circ}\text{C}/0.01^{\circ}\text{F}$
hex	dec	[$^{\circ}\text{C}$]/[$^{\circ}\text{F}$]	[$^{\circ}\text{C}$]/[$^{\circ}\text{F}$]
$\text{xxxx xxxx xxxx xxx}1_{bin}$		Overrange (AV = positive final value from the table on page 22)	
2710	10000	1000.0	100.00
03E8	1000	100.0	10.00
0008	8	0.8	0.08
0000	0	0	0
FFF8	-8	-0.8	-0.08
FC18	-1000	-100.0	-10.00
$\text{xxxx xxxx xxxx xxx}1_{bin}$		Underrange (AV = negative final value from the table on page 22)	
$\text{xxxx xxxx xxxx xx}1_{bin}$		Open circuit/short circuit (AV = negative final value from the table on page 22)	

AV	Analog value
x	Can have the value 0 or 1



If the measured value is outside the representation area of the process data, bit 0 is set to 1.
In the event of an open/short circuit, bit 1 is set to 1.

15.3 S7-compatible format

The measured value is represented in bits 14 to 0. An additional bit (bit 15) is available as a sign bit.

Measured value representation in S7-compatible format; 15 bits

MSB	15	14	13	12	11	10	9	8	7	6	5	4	3	2	1	0	LSB
SB	Analog value																

SB Sign bit

AV Analog value

IB input data word (Two's complement) (hex)	All temperature sensors Resolution 0.1°C or 0.1°F (°C) or (°F)	All temperature sensors Resolution 0.01°C or 0.01°F (°C) or (°F)
7FFF	Overrange	Overrange
2710 (10000)	1000.0	100.0
03E8 (1000)	100.0	10.00
0008 (8)	0.8	0.08
0000	0	0
FFF8 (-8)	-0.8	-0.08
FC18 (-1000)	-100.0	-10
8000	Underrange	Underrange

16 PCP communication



For information on PCP communication, please refer to the IBS SYS PCP G4 UM E and IBS PCP COMPACT UM E user manuals.

By default upon delivery, the terminal is configured according to the default settings on page 10. The terminal can be configured using process data or PCP to suit your application.

In PCP mode, the terminal is configured with the "Config Table" object.



The IBS CMD (for standard controller boards) and IBS PC WORX (for Field Controllers (FC) and Remote Field Controllers (RFC)) programs are available for the configuration and parameterization of your INTERBUS system.

For additional information, please refer to the "IBS CMD SWT G4 UM E" user manual and the documentation for the version of PC WORX used.

16.1 Object dictionary

Index	Data type	A	L	Meaning	Object name	Rights
0080 _{hex}	Array of Unsigned 16	12	2		Config table	rd/wr
0081 _{hex}	Array of Unsigned 16	8	2		Analog Values	rd

A: Number of elements

rd: Read access permitted

L: Length of an element in bytes

wr: Write access permitted

16.2 Object descriptions

Config Table object

Configure the terminal using this object.



If you configure the terminal using PCP and the "Conf" bit equals 0 in the "System bit" element, parameterization via process data is disabled.

Set the "Conf" bit to 1 in order to enable parameterization via process data in addition to parameterization via PCP.

Object description:

Object	Config table	
Access	Read, Write	
Data type	Array of Unsigned 16	12 x 2 bytes
Index	0080 _{hex}	
Subindex	00 _{hex}	Write all elements
	01 _{hex}	Configuration of channel 1
	02 _{hex}	Configuration of channel 2
	03 _{hex}	Configuration of channel 3
	04 _{hex}	Configuration of channel 4
	05 _{hex}	Configuration of channel 5
	06 _{hex}	Configuration of channel 6
	07 _{hex}	Configuration of channel 7
	08 _{hex}	Configuration of channel 8
	09 _{hex}	Reserved
	0A _{hex}	System bit
	0B _{hex}	Reserved
	0C _{hex}	Reserved
Length (bytes)	18 _{hex}	Subindex 00 _{hex}
	02 _{hex}	Subindex 01 _{hex} to 0C _{hex}
Data	Terminal configuration	

Element value range

The "**Configuration channel x**" elements have the following structure:

Bit	15	14	13	12	11	10	9	8	7	6	5	4	3	2	1	0
Assignment	0	Filter		2/3	R ₀			Resolution	Format		Sensor type					

For the value ranges of the individual parameters, please refer to "Parameters for configuration" on page 12.

If an invalid configuration is specified, a negative confirmation is generated with error message 08_{hex}, 00_{hex} or xx30_{hex}. The low byte of the additional error code is 30_{hex} (value is out of range), the high byte contains the number of the affected element.

Example: Config Table is completely filled with data (subindex 00) and the entry for channel 6 is invalid. In this case, the additional error code equals 0630_{hex}.

The "System bit" element is set up as follows:

Bit	15	14	13	12	11	10	9	8	7	6	5	4	3	2	1	0
Assignment	0	0	0	0	0	0	0	0	0	0	0	0	0	0	0	Conf

"Conf"

If bit 0 = 0, configuration via process data is disabled (default). "Conf"

If bit 0 = 1, configuration via process data is permitted (command codes 40xx_{hex} and 6000_{hex}).

Analog Values object

The elements of this object contain the analog values of the channels in a format that has been selected for this channel.

Object description:

Object	Analog Values	
Access	Read	
Data type	Array of Unsigned 16	8 x 2 bytes
Index	0081 _{hex}	
Subindex	00 _{hex}	Read all elements
	01 _{hex}	Analog value of channel 1
	02 _{hex}	Analog value of channel 2
	03 _{hex}	Analog value of channel 3
	04 _{hex}	Analog value of channel 4
	05 _{hex}	Analog value of channel 5
	06 _{hex}	Analog value of channel 6
	07 _{hex}	Analog value of channel 7
	08 _{hex}	Analog value of channel 8
Length (bytes)	10 _{hex}	Subindex 00 _{hex}
	02 _{hex}	Subindex 01 _{hex} to 08 _{hex}
Data	Analog values of the channels	

17 Configuration and analog values

The terminal only needs to be configured if the channels are not to be operated with the default values (see "Parameters for configuration" on page 12).

You can **either** configure the terminal via process data or via PCP and transmit analog values accordingly.

If you have configured the terminal via PCP, the configuration can no longer be modified via the process data.

Examples for terminal configuration via process data



For easy terminal configuration a function block can be downloaded at www.phoenixcontact.net/catalog

Example 1

All channels are to be configured as Ni1000 in 3-wire technology with 16-sample mean value generation. IBIL is used as format with a resolution of 0.1°C. The configuration value is therefore 0002_{hex}.

Step	Process data	Meaning
1	OUT2 = 0C02 _{hex} OUT1 = 6000 _{hex}	Specify configuration
2	Wait until IN1 = 6000 _{hex}	Wait for confirmation
3	OUT1 = 0800 _{hex}	Request the measured values of channels 1 to 4
4	Wait until IN1 = 0800 _{hex}	Wait for confirmation
5	Measured value channel 1 = IN2, ..., Measured value channel 4 = IN5 if measured value = 80xx _{hex} , an error message is sent, otherwise temperature in °C = measured value x 10	Read measured values
6	OUT1 = 0900 _{hex}	Request the measured values of channels 5 to 8
7	Wait until IN1 = 0900 _{hex}	Wait for confirmation
8	Measured value channel 5 = IN2, ..., Measured value channel 8 = IN5	Read measured values

Example 2

Each channel is configured differently.

Step	Process data	Meaning
1	OUT2 = configuration for channel 1 OUT1 = 4000 _{hex}	Specify configuration K1
2	Wait until IN1 = 4000 _{hex}	Wait for confirmation
3	OUT2 = configuration for channel 2 OUT1 = 4100 _{hex}	Specify configuration C2
4	Wait until IN1 = 4100 _{hex}	Wait for confirmation
5	OUT2 = configuration for channel 3 OUT1 = 4200 _{hex}	Specify configuration K3
6	Wait until IN1 = 4200 _{hex}	Wait for confirmation
...
15	OUT2 = configuration for channel 8 OUT1 = 4700 _{hex}	Specify configuration K8
16	Wait until IN1 = 4700 _{hex}	Wait for confirmation

18 Measuring ranges

18.1 Measuring ranges depending on the resolution (IB IL format)



Temperature values can be converted from °C to °F with this formula:

$$T [^{\circ}\text{F}] = T [^{\circ}\text{C}] \times \frac{9}{5} + 32$$

Where:

T [°F] Temperature in °F

T [°C] Temperature in °C

Resolution	Temperature sensors
00	-273°C to +3276.8°C; resolution: 0.1°C
01	-273°C to +327.68°C; resolution: 0.01°C
10	-459°F to +3276.8°F; resolution: 0.1°F
11	-459°F to +327.68°F; resolution: 0.01°F

18.2 Input measuring ranges

No.	Input	Sensor type		Measuring range	
				Lower limit	Upper limit
0	Temperature sensors	Pt R ₀ 10 Ω to 2000 Ω	According to DIN EN 60751: 07/1996	-200°C	+850°C
0		Pt10000		-200°C	+180°C
1		Pt R ₀ 10 Ω to 2000 Ω	According to SAMA	-200°C	+850°C
1		Pt10000		-200°C	+180°C
2		Ni R ₀ 10 Ω to 2000 Ω	According to DIN EN 60751: 07/1996	-60°C	+180°C
3		Ni R ₀ 10 Ω to 2000 Ω	According to SAMA	-60°C	+180°C
4		Cu10	According to SAMA	-70°C	+500°C
5		Cu50	According to SAMA	-50°C	+200°C
6		Cu53	According to SAMA	-50°C	+180°C
7		Ni1000 L&G		-50°C	+160°C
8		Ni500 (Viessmann)		-60°C	+250°C
9		KTY81-110		-55°C	+150°C
10		KTY84		-40°C	+300°C
11		KTY81-210		-55°C	+150°C
12	Reserved				
13	Relative potentiometer range			0%	R0 (100%)
14	Linear resistance measuring range			0 Ω	400 Ω
15				0 Ω	20000 Ω



The number (No.) corresponds to the code of the sensor type in bit 3 to bit 0 of the parameter word (see "Sensor type" on page 13).

Please note for the potentiometer (No. 13) and linear resistor (No. 14 and 15) sensor types that below 0.8% of the nominal range (e.g., 0 Ω to 3 Ω for the "linear R: 0 to 400 Ω" type) the diagnostic messages "Overrange" and "Underrange" can be generated.

19 Measuring errors

19.1 Systematic measuring errors during temperature measurement using resistance thermometers

When measuring temperatures using resistance thermometers, systematic measuring errors are often the cause for incorrect measuring results.

The sensors can be connected in 2 or 3-wire technology.

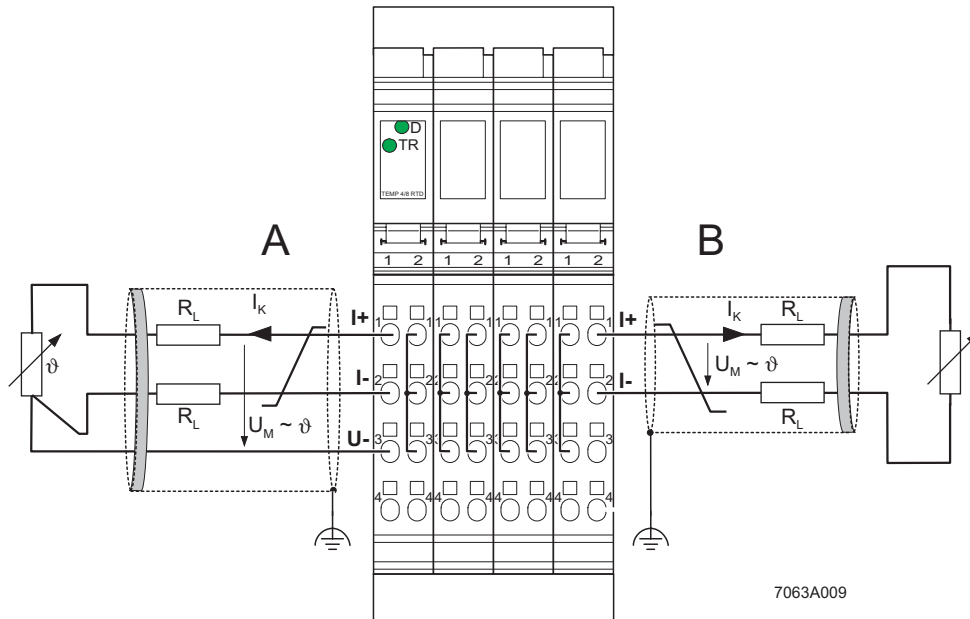

Figure 7 Connecting the resistance thermometers in 3-wire technology (A) and 2-wire technology (B)

With **3-wire technology**, the effect of the cable resistance on the measured result in the terminal is eliminated or minimized by multiple measuring of the temperature-related voltage and corresponding calculations.

2-wire technology is a more cost-effective connection method. The U+ and U- cables are no longer needed. The temperature-related voltage is not directly measured at the sensor and therefore falsified by the two cable resistances R_L . This connection method is particularly well suited for sensors with high R_0 (e.g., Pt1000, Pt10000, Ni1000).

The measuring errors that occur if R_0 is low can make the entire measurement unusable (see diagrams in Figure 8 to Figure 10). However, these diagrams show at which points in the measurement system measures can be taken to minimize these errors.

19.2 Systematic errors during temperature measurement using 2-wire technology

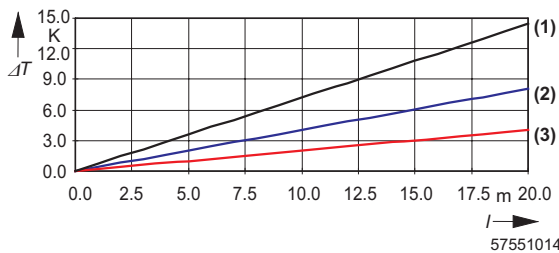

Figure 8 Systematic temperature measuring error ΔT depending on the cable length l

Curves depending on cable cross section A

- (1) Temperature measuring error for $A = 0.14 \text{ mm}^2$
- (2) Temperature measuring error for $A = 0.25 \text{ mm}^2$
- (3) Temperature measuring error for $A = 0.50 \text{ mm}^2$

(Measuring error valid for: copper cable $\chi = 57 \text{ m}/\Omega\text{mm}^2$, $T_A = 25^\circ\text{C}$ and Pt 100 sensor)

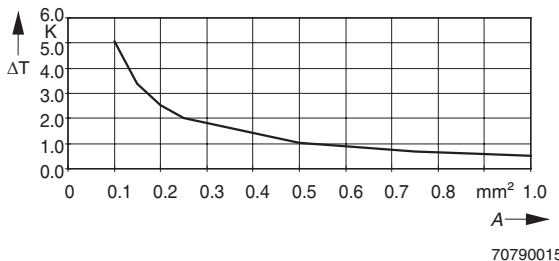

Figure 9 Systematic temperature measuring error ΔT depending on the cable cross section A

(Measuring error valid for: copper cable $\chi = 57 \text{ m}/\Omega\text{mm}^2$, $T_A = 25^\circ\text{C}$, $l = 5 \text{ m}$, and Pt 100 sensor)

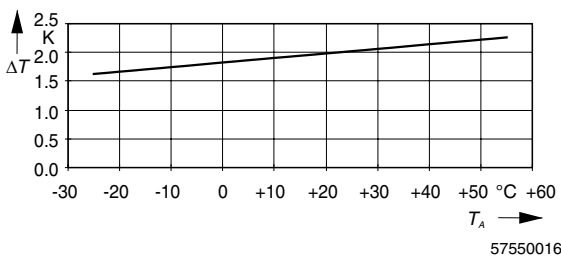

Figure 10 Systematic temperature measuring error ΔT depending on the cable temperature T_A

(Measuring error valid for: copper cable $\chi = 57 \text{ m}/\Omega\text{mm}^2$, $l = 5 \text{ m}$, $A = 0.25 \text{ mm}^2$, and Pt 100 sensor)

All diagrams show that the increase in cable resistance causes the measuring error.

A considerable improvement is made through the use of Pt 1000 sensors. Due to the 10 times higher temperature coefficient α ($\alpha = 0.385 \text{ } \Omega/\text{K}$ for Pt100 to $\alpha = 3.85 \text{ } \Omega/\text{K}$ for Pt1000) the effect of the cable resistance on the measurement is decreased by a factor of 10. All errors in the diagrams above would be reduced by factor 10.

Figure 8 clearly shows the effect of the cable length on the cable resistance and therefore on the measuring error. The solution is to use the shortest possible sensor cables.

Figure 9 shows the influence of the cable cross-section on the cable resistance. It can be seen that cables with a cross section of less than 0.5 mm^2 cause errors to increase exponentially.

Figure 10 shows the influence of the ambient temperature on the cable resistance. This parameter is of minor importance and can hardly be influenced. It is mentioned here only for the sake of completeness.

The formula for calculating the cable resistance is as follows:

$$R_L = R_{L20} \times \left(1 + 0.0039 \frac{1}{K} \times (T_A - 20^\circ\text{C}) \right)$$

$$R_L = \frac{l}{\chi \times A} \times \left(1 + 0.0039 \frac{1}{K} \times (T_A - 20^\circ\text{C}) \right)$$

Where:

- R_L Cable resistance in Ω
- R_{L20} Cable resistance at 20°C in Ω
- l Cable length in m
- χ Specific electrical conductivity of copper in $\Omega\text{mm}^2/\text{m}$
- A Cable cross section in mm^2
- 0.0039 1/K Temperature coefficient for copper (degree of purity of 99.9%)
- T_A Ambient temperature (cable temperature) in $^\circ\text{C}$

Since there are two cable resistances in the measuring system (forward and return), the value must be doubled.

The absolute measuring error in Kelvin [K] is provided for platinum sensors according to DIN using the average temperature coefficient α ($\alpha = 0.385 \text{ } \Omega/\text{K}$ for Pt100; $\alpha = 3.85 \text{ } \Omega/\text{K}$ for Pt1000).

20 General notes and recommendations for the signal/noise ratio

Optimizing the signal/noise ratio in RTD applications using the IB IL TEMP 4/8 RTD terminal.

Background:

The terminal used has a high dynamic performance and can quickly detect the smallest changes in resistance or temperature. In practice, however, a Pt100 sensor in air immediately passes on even the smallest changes. Temperature fluctuations due to air circulation are measured immediately and are transmitted to the higher-level PLC.

Remedy:

High dynamics is not required for all applications. In order to obtain more stable measured values, set the internal filtering parameter to 32-sample filtering. Moreover, an additional application filter can improve the signal/noise ratio. As far as noise levels are concerned, 2-wire operation is more favorable than 3-wire operation.

The thermal system at the sensor can be slowed, if required. This can be achieved, for example, by installing it on a body with a high thermal storage capacity. This could be, for example, a metal block of aluminum or steel. The signal/noise ratio will be influenced positively.

Overview of the recommended measures for temperature measurements with minimized noise:

No.	Sensor type	Filter	Connection	Remarks	Other
1	Pt100 Ni100	32	2/3	With regard to the signal/noise ratio it is much better to use 2-wire termination instead of 3-wire termination for terminal operation. Check the tolerances for each respective measuring task.	<ul style="list-style-type: none"> – Short circuit unused channels. – Enlarge the sensor ground (connect sensor ground, for example, to a metal block). – If required, use an additional application filter.
2	Pt1000 Ni1000	32	2	Check the tolerances for each respective measuring task.	
3	Pt10000	32	2	Due to the high R_0 , a 2-wire connection is recommended, ideally with long supply lines. In addition, when using a 2-wire connection, the signal/noise ratio is more favorable. (Example: In order to keep the influence of the cable resistance at a value of $< 0.1 \text{ K}$, the copper cable may be up to 110 m long with a cross-section of 0.25 mm^2 .)	

21 Step response

The step response is the time when a step of the analog input variables (temperature, resistance) is available as a measured value in the IN process data.

It consists of several time parts.

(Basic value + 3-wire additional time + transient period) x filter x number of channels = step response



The 3-wire additional time is only required for 3-wire measurements.

Basic value	3-wire additional time	Transient period	Filter	Number of channels
1.5 ms	0.3 ms	0 ms or 3 ms	16-sample: 16 No mean-value generation: 1 4-sample: 4 32-sample: 32	Normally: 8 Convert only 4 channels (command 0A): 4

The transient period depends on the sensor type.

Transient period 0 ms per channel for the following sensor types:	Transient period 3 ms per channel for the following sensor types:
<ul style="list-style-type: none"> - Pt10 to Pt100 - Ni10 to Ni100 - Cu10, Cu50, Cu53 - Potentiometer [%] - Linear R: 0 to 400 Ω 	<ul style="list-style-type: none"> - Ni1000 (Landis & Gyr) - Ni500 (Viessmann) - KTY 81-110 - KTY 84 - KTY 81-210 - Linear R: 0 to 20000 Ω

Examples

Configuration	Basic value	3-wire additional time	Transient period	Filter	Number of channels	Time
0000 _{hex} = Default: Pt100, 3-wire, 16-sample mean-value generation	1.5 ms	0.3 ms	0 ms	16	8	230 ms
4C02 _{hex} : Ni1000, 2-wire, 4-sample mean-value generation	1.5 ms	0 ms	3 ms	4	8	144 ms
2000 _{hex} : Pt100, 3-wire, no mean-value generation, convert only four channels	1.5 ms	0.3 ms	0 ms	1	4	7.2 ms
3000 _{hex} : Pt100, 2-wire, no mean-value generation, convert only four channels	1.5 ms	0 ms	0 ms	1	4	6 ms



The INTERBUS runtimes and the time between sending a command and sending the next command are not included in the calculations.



SCATTERGOOD & JOHNSON LTD

ELECTRICAL ENGINEERING & FLUID CONTROL DISTRIBUTORS

Est.1899

At Scattergood & Johnson Ltd, we pride ourselves on being a technical distributor to specialist industries.

Working with a range of quality product suppliers across a number of specialist markets, we are not your average 'box shifter' - we are your technical and supply chain partner.

We fully support every product we sell - for free! Our internal team and external sales engineers can answer any product or application question, no matter the complexity.

Backing up this technical ability is a range of 50,000+ products available from stock for nationwide next day delivery (same day if required!), or you can collect what you need from any of our trade counters around the UK.

Select your specialist interest below to learn more about how we can help.

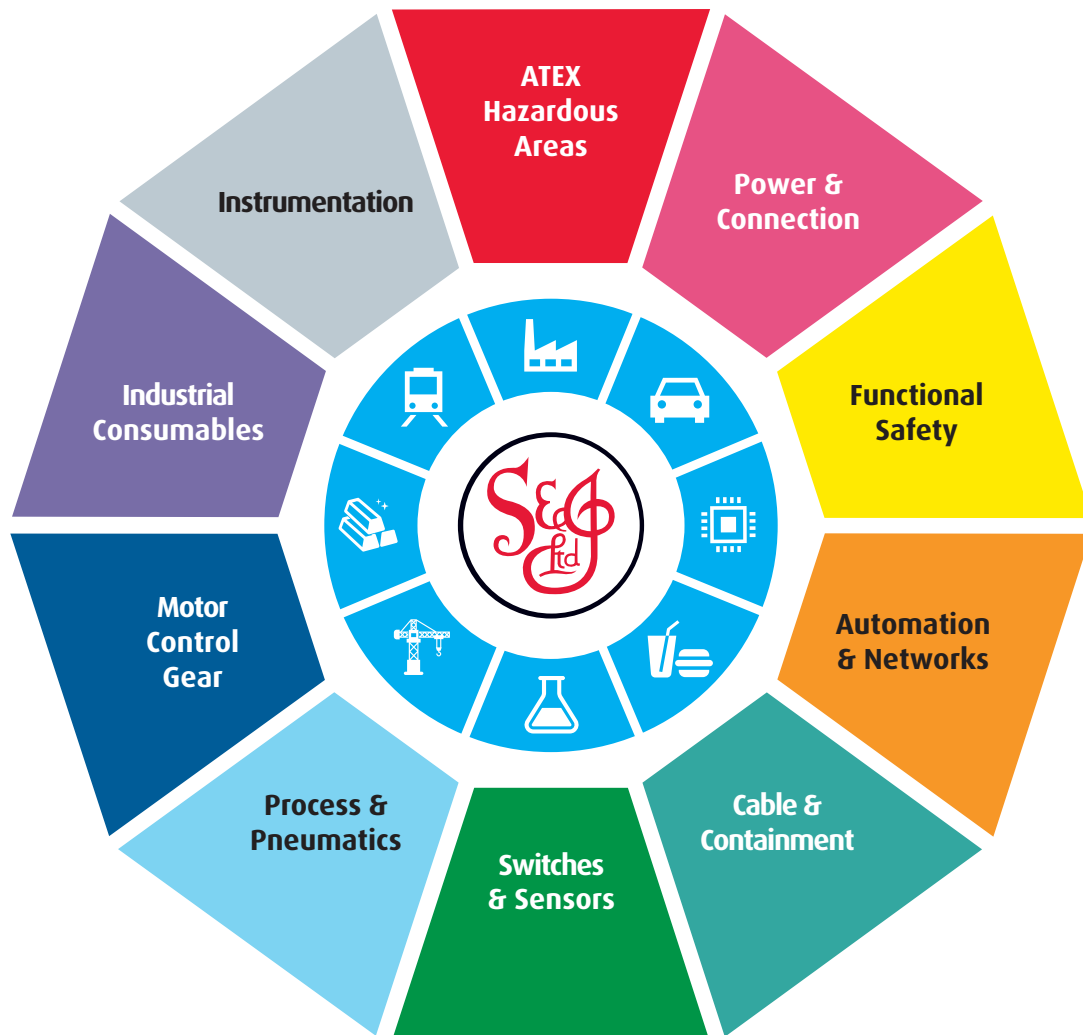

Online, In Branch and On the Road - Scattergood & Johnson Ltd, there when you need us.

www.scatts.co.uk