

IB IL 24 DI 4-ME

**Inline digital input terminal,
Inline ME versions (Machine Edition),
4 inputs, 24 V DC**

Data sheet
7035_en_01

© PHOENIX CONTACT 2014-04-07

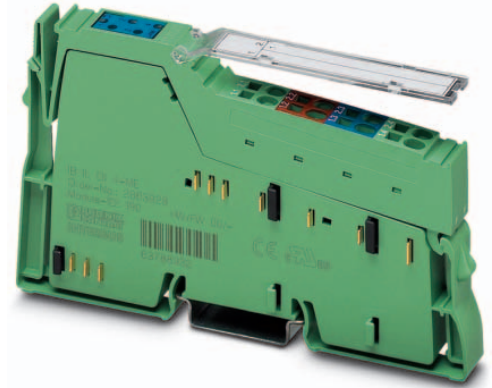

1 Description

The terminal block has been developed for use in an Inline station. It is used to acquire digital signals.

Features

- Connections for four digital sensors
- Connection of 2 or 3-wire sensors
- Maximum permissible load current per sensor: 250 mA
- Maximum permissible load current from the terminal:
1 A
- Diagnostic and status indicators



This data sheet is only valid in association with the IL SYS INST UM E user manual.



Make sure you always use the latest documentation.
It can be downloaded from the product at phoenixcontact.net/products.

2	Table of contents	
1	Description	1
2	Table of contents	2
3	Ordering data	3
4	Technical data	3
5	Additional tables	6
	5.1 Input characteristic curve	6
	5.2 Power dissipation	6
	5.3 Limitation of simultaneity, derating	6
6	Internal circuit diagram	6
7	Local status and diagnostic indicators	7
8	Terminal point assignment.....	7
9	Connection notes and examples	8
10	Process data.....	8

3 Ordering data

Description	Type	Order No.	Pcs. / Pkt.
Inline digital input terminal, Inline ME versions (machine edition) complete with accessories (connector and labeling field), FOUR inputs, 24 V DC, 2, 3-conductor connection method	IB IL 24 DI 4-ME	2863928	4
Accessories	Type	Order No.	Pcs. / Pkt.
Connector, for digital 1, 2 or 8-channel Inline terminals (Connector/ Adapter)	IB IL SCN-8	2726337	10
Labeling field, width: 12.2 mm (Marking)	IB IL FIELD 2	2727501	10
Insert strip, Sheet, white, Unlabeled, can be labeled with: Office printing systems, Plotter: Laser printer, Mounting type: Insert, Lettering field: 62 x 10 mm (Marking)	ESL 62X10	0809492	1
Inline terminal for power distribution (24 V), complete with accessories, (connector and labeling field) 24 V supply voltage is fed out from the segment circuit (US)	IB IL PD 24V-PAC	2862987	1
Inline terminal for power distribution (GND), complete with accessories, (connector and labeling field) connections for GND	IB IL PD GND-PAC	2862990	1
Documentation	Type	Order No.	Pcs. / Pkt.
Application note, English, The safety-related segment circuit	AH EN IL SAFE	-	-
Data sheet, English, INTERBUS addressing	DB GB IBS SYS ADDRESS	-	-

4 Technical data

Dimensions (nominal sizes in mm)

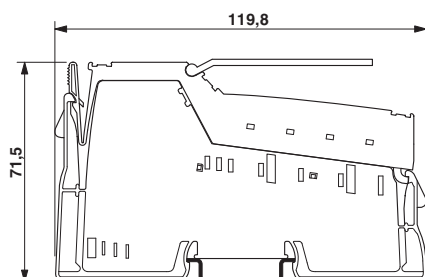

Width	12.2 mm
Height	119.8 mm
Depth	71.5 mm

General data

Color	green
Weight	59 g (With connector)
Operating mode	Process data operation with 4 bits
Ambient temperature (operation)	-25 °C ... 55 °C
Ambient temperature (storage/transport)	-25 °C ... 85 °C

General data	
Permissible humidity (operation)	10 % ... 95 % (according to DIN EN 61131-2)
Permissible humidity (storage/transport)	10 % ... 95 % (according to DIN EN 61131-2)
Air pressure (operation)	70 kPa ... 106 kPa (up to 3000 m above sea level)
Air pressure (storage/transport)	70 kPa ... 106 kPa (up to 3000 m above sea level)
Degree of protection	IP20
Protection class	III, IEC 61140, EN 61140, VDE 0140-1

Connection data	
Designation	Inline connector
Connection method	Spring-cage connection
Conductor cross section solid / stranded	0.08 mm ² ... 1.5 mm ² / 0.08 mm ² ... 1.5 mm ²
Conductor cross section [AWG]	28 ... 16

Connection data for UL approvals	
Designation	Inline connector
Connection method	Spring-cage connection
Conductor cross section solid / stranded	0.2 mm ² ... 1.5 mm ² / 0.2 mm ² ... 1.5 mm ²
Conductor cross section [AWG]	24 ... 16

Interface Inline local bus	
Connection method	Inline data jumper
Transmission speed	500 kBit/s
Transmission physics	Copper

Power consumption	
Segment supply voltage U_S	24 V DC (nominal value)
Current consumption from U_S	max. 1 A
Communications power U_L	7.5 V DC
Current consumption from U_L	max. 40 mA
Power consumption	max. 0.3 W (at U_L)

Digital inputs	
Number of inputs	4 (EN 61131-2 type 1)
Connection method	Spring-cage connection
Connection method	2, 3-wire
Nominal input voltage	24 V DC
Input voltage range	-30 V DC ... 30 V DC
Nominal input current	min. 3 mA (at nominal voltage)
Input voltage range "0" signal	-3 V DC ... 5 V
Input voltage range "1" signal	15 V DC ... 30 V DC
Permissible conductor length to the sensor	30 m
Use of AC sensors	AC sensors in the voltage range $< U_{IN}$ are limited in application (according to the input design)

Programming Data

ID code (hex)	BE
ID code (dec.)	190
Length code (hex)	41
Length code (dec.)	65
Process data channel	0 Bit
Input address area	4 Bit
Output address area	0 Bit
Parameter channel (PCP)	0 Byte
Register length (bus)	4 Bit



For the programming data/configuration data of other bus systems, please refer to the corresponding electronic device data sheet (e.g., GSD, EDS).

Fieldbus data telegram

Fieldbus system	PROFIBUS DP
Required parameter data	1 Byte
Need for configuration data	4 Byte

Error messages to the higher level control or computer system

None

Electrical isolation/isolation of the voltage areas

Test section	Test voltage
7.5 V supply (bus logics)/24 V supply (I/O)	500 V AC, 50 Hz, 1 min
7.5 V supply (bus logics) / functional earth ground	500 V AC, 50 Hz, 1 min
24 V supply (I/O) / functional earth ground	500 V AC, 50 Hz, 1 min



To achieve electrical isolation between the logic level and the I/O area, supply these areas from separate power supply units. Interconnection of the power supply units in the 24 V area is not permitted (see also user manual).

Approvals

For the latest approvals, please visit phoenixcontact.net/products.

5 Additional tables

5.1 Input characteristic curve

Current depending on the input voltage and the ambient temperature T_A			
Supply voltage [V]	Input current [mA]	Input current for $t \geq 20$ s [mA]	
		$T_A = 25^\circ\text{C}$	$T_A = 55^\circ\text{C}$
18	3.0	2.9	2.5
24	3.9	3.8	3.5
30	4.5	4.2	3.0

The current is reduced depending on the ambient temperature and the number of inputs that are switched on (internal module temperature).

5.2 Power dissipation

Formula for calculating the power dissipation of the electronics

$$P_{EL} = 0,24 \text{ W} + \sum_{i=1}^n (U_{INi} \times 0,003 \text{ A})$$

Where:

- P_{EL} Total power dissipation in the terminal
- i Continuous index
- n Number of set inputs ($n = 1 \dots 4$)
- U_{INi} Input voltage of input i

Power dissipation of the housing

Maximum 0.6 W (within the permissible operating temperature)

5.3 Limitation of simultaneity, derating

No limitation of simultaneity, no derating

6 Internal circuit diagram

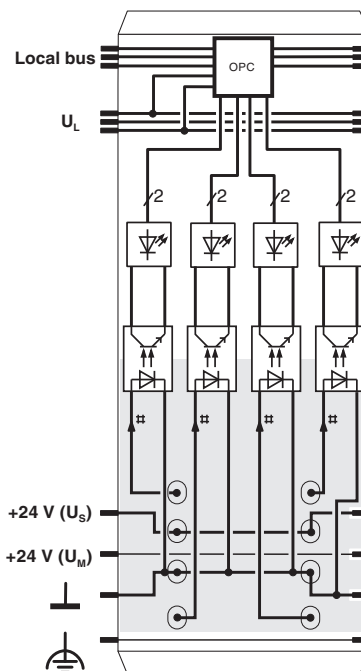







Figure 1 Internal wiring of the terminal points

Key:

-  Protocol chip (Bus logic including voltage conditioning)
-  LED (status indicator)
-  Optocoupler
-  Digital input
-  Electrically isolated area



Explanation for other used symbols has been provided in the IL SYS INST UM E user manual.

7 Local status and diagnostic indicators

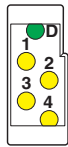

Figure 2 Local status and diagnostic indicators

Designation	Color	Meaning
D	Green	Diagnostics (bus and logic voltage)
1 ... 4	Yellow	Status of the inputs

8 Terminal point assignment

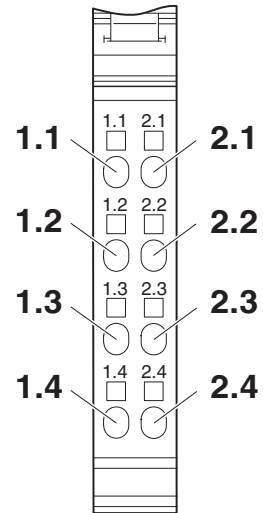

Figure 3 Terminal point assignment

Terminal point	Assignment
1.1 / 2.1	Signal input (IN 1 / IN 2)
1.2 / 2.2	Segment voltage U_S for 2 and 3-wire connection
1.3 / 2.3	Ground contact (GND) for 3-wire connection
1.4 / 2.4	Signal input (IN 3 / IN 4)

9 Connection notes and examples

i When connecting the sensors observe the assignment of the terminal points to the process data.

! **NOTE: Malfunction**
The sensors and U_S must be supplied from the same voltage supply.

The simplest way to meet this requirement is to use the IB IL PD 24V-PAC terminal. Wire the 24 V sensor connections to this terminal. In this way, they are supplied from the potential jumper U_S of the Inline station.

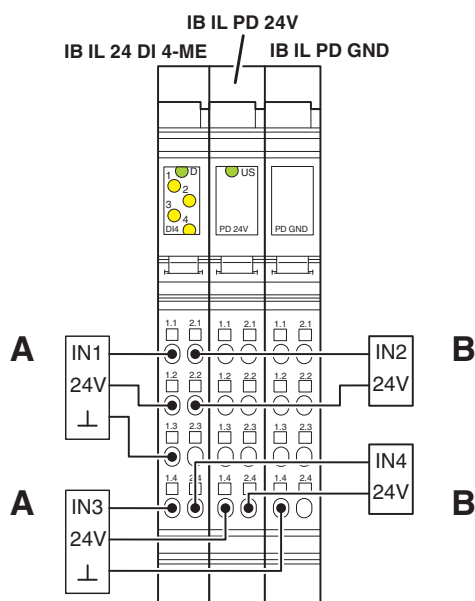

Figure 4 Typical connection of sensors when terminals for potential distribution are used

- A 3-wire termination
- B 2-wire termination

The sensors can also be connected via external busbars. Ensure that the sensors and U_S are supplied from the same voltage supply.

When using external power rails, make sure that the ground (GND) has a reference to the Inline system ground.

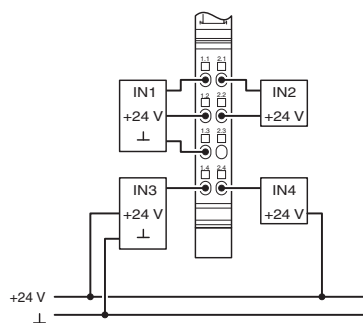

Figure 5 Example of a connection of sensors when using external busbars

10 Process data

Assignment of the terminal points to IN process data

(Byte.Bit) view	Byte.Bit	0.3	0.2	0.1	0.0
Assignment	Terminal point (signal)	2.4	1.4	2.1	1.1
	Terminal point (24 V)	-	-	2.2	1.2
	Terminal point (GND)	-	-	2.3	1.3
Status indicator	LED	4	3	2	1

i For the assignment of the illustrated (byte.bit) view to your INTERBUS control or computer system, please refer to the DB GB IBS SYS ADDRESS data sheet.



SCATTERGOOD & JOHNSON LTD

ELECTRICAL ENGINEERING & FLUID CONTROL DISTRIBUTORS

Est.1899

At Scattergood & Johnson Ltd, we pride ourselves on being a technical distributor to specialist industries.

Working with a range of quality product suppliers across a number of specialist markets, we are not your average 'box shifter' - we are your technical and supply chain partner.

We fully support every product we sell - for free! Our internal team and external sales engineers can answer any product or application question, no matter the complexity.

Backing up this technical ability is a range of 50,000+ products available from stock for nationwide next day delivery (same day if required!), or you can collect what you need from any of our trade counters around the UK.

Select your specialist interest below to learn more about how we can help.



Online, In Branch and On the Road - Scattergood & Johnson Ltd, there when you need us.

www.scatts.co.uk