

IB IL 24 DO 4-ME

**Inline digital output terminal,
Inline ME versions (Machine Edition),
4 outputs, 24 V DC, 500 mA**

Data sheet
7036_en_01

© PHOENIX CONTACT 2014-04-07

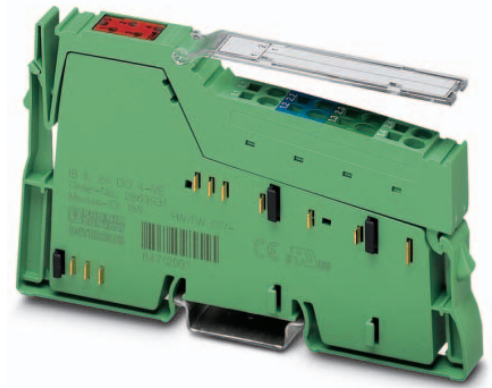

1 Description

The terminal is designed for use within an Inline station. It is used to output digital signals.

Features

- Connections for four digital actuators
- Connection of actuators in 2 and 3-wire technology
- Nominal current per output: 0.5 A
- Total current of the terminal: 2 A
- Short-circuit and overload protected outputs
- Diagnostic and status indicators



This data sheet is only valid in association with the IL SYS INST UM E user manual.



Make sure you always use the latest documentation.
It can be downloaded from the product at phoenixcontact.net/products.

2	Table of contents	
1	Description	1
2	Table of contents	2
3	Ordering data	3
4	Technical data	3
5	Additional tables	6
	5.1 Output characteristic curve.....	6
	5.2 Power dissipation	6
	5.3 Limitation of simultaneity, derating	6
6	Internal circuit diagram	7
7	Local status and diagnostic indicators	7
8	Terminal point assignment.....	7
9	Connection notes and examples	8
10	Process data.....	8

3 Ordering data

Description	Type	Order No.	Pcs. / Pkt.
Inline digital output terminal, Inline ME versions (machine edition) complete with accessories (connector and labeling field), four outputs, 24 V DC, 500 mA, 2, 3-conductor connection method	IB IL 24 DO 4-ME	2863931	4
Accessories	Type	Order No.	Pcs. / Pkt.
Connector, for digital 1, 2 or 8-channel Inline terminals (Connector/Adapter)	IB IL SCN-8	2726337	10
Labeling field, width: 12.2 mm (Marking)	IB IL FIELD 2	2727501	10
Insert strip, Sheet, white, Unlabeled, can be labeled with: Office printing systems, Plotter: Laser printer, Mounting type: Insert, Lettering field: 62 x 10 mm (Marking)	ESL 62X10	0809492	1
Inline terminal for power distribution (GND), complete with accessories, (connector and labeling field) connections for GND	IB IL PD GND-PAC	2862990	1
Documentation	Type	Order No.	Pcs. / Pkt.
Application note, English, The safety-related segment circuit	AH EN IL SAFE	-	-
Data sheet, English, INTERBUS addressing	DB GB IBS SYS ADDRESS	-	-

4 Technical data

Dimensions (nominal sizes in mm)

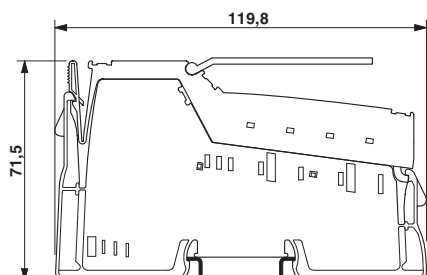

Width	12.2 mm
Height	119.8 mm
Depth	71.5 mm

General data

Color	green
Weight	59 g (With connector)
Operating mode	Process data operation with 4 bits
Ambient temperature (operation)	-25 °C ... 55 °C
Ambient temperature (storage/transport)	-25 °C ... 85 °C
Permissible humidity (operation)	10 % ... 95 % (according to DIN EN 61131-2)
Permissible humidity (storage/transport)	10 % ... 95 % (according to DIN EN 61131-2)
Air pressure (operation)	70 kPa ... 106 kPa (up to 3000 m above sea level)

General data

Air pressure (storage/transport)	70 kPa ... 106 kPa (up to 3000 m above sea level)
Degree of protection	IP20
Protection class	III, IEC 61140, EN 61140, VDE 0140-1

Connection data

Designation	Inline connector
Connection method	Spring-cage connection
Conductor cross section solid / stranded	0.08 mm ² ... 1.5 mm ² / 0.08 mm ² ... 1.5 mm ²
Conductor cross section [AWG]	28 ... 16

Connection data for UL approvals

Designation	Inline connector
Connection method	Spring-cage connection
Conductor cross section solid / stranded	0.2 mm ² ... 1.5 mm ² / 0.2 mm ² ... 1.5 mm ²
Conductor cross section [AWG]	24 ... 16

Interface Inline local bus

Connection method	Inline data jumper
Transmission speed	500 kBit/s
Transmission physics	Copper

Power consumption

Segment supply voltage U_S	24 V DC (nominal value)
Current consumption from U_S	max. 2 A
Communications power U_L	7.5 V DC
Current consumption from U_L	max. 44 mA
Power consumption	max. 0.33 W (at U_L)

Digital outputs

Number of outputs	4
Connection method	Spring-cage connection
Connection method	2, 3-wire
Nominal output voltage	24 V DC (voltage difference at $I_{nom} \leq 1$ V)
Voltage difference with nominal current	≤ 1 V
Maximum output current per channel	500 mA
Maximum output current per device	2 A
Nominal load, ohmic	12 W (48 Ω)
Nominal load, inductive	12 VA (1.2 H; 50 Ω)
Nominal load, lamp	12 W
Signal delay when switching on an ohmic nominal load	typ. 100 μ s
Signal delay when switching on an inductive nominal load	typ. 100 ms (1.2 H; 50 Ω)
Signal delay when switching on a lamp nominal load	typ. 100 ms (for switching frequencies up to 8 Hz; above this frequency, the lamp load behaves like an ohmic load)
Signal delay when switching off an ohmic nominal load	typ. 1 ms
Signal delay when switching off an inductive nominal load	typ. 50 ms (1.2 H; 50 Ω)
Signal delay when switching off a lamp nominal load	typ. 1 ms
Maximum operating frequency with ohmic nominal load	max. 300 Hz (this switching frequency is limited by the number of bus devices, the structure of the bus, the software used and the control or computer system used)
Maximum operating frequency with inductive nominal load	max. 0.5 Hz (1.2 H; 50 Ω)
Maximum operating frequency with lamp nominal load	max. 300 Hz (this switching frequency is limited by the number of bus devices, the structure of the bus, the software used and the control or computer system used)

Digital outputs

Reaction time with short-circuit	ca. 850 ms
Reaction time with ohmic overload	ca. 3 s
Behavior at voltage switch-off	The output follows the power supply without delay
Output data validity	typ. 5 ms (after switching the 24 V voltage supply (power up))
One-time unsolicited energy	400 mJ
Limitation of the voltage induced on circuit interruption	-46 V ... -15 V
Output voltage when switched off	max. 2 V
Output current when switched off	max. 300 µA
Behavior with overload	Auto restart
Restart frequency with ohmic overload	250 Hz
Restart frequency with lamp overload	250 Hz
Behavior with inductive overload	Output can be destroyed
Reverse voltage resistance to short pulses	Reverse voltage proof
Resistance to permanent reverse voltage	to 2 A DC
Resistance to permanently applied surge voltage	No
Overcurrent shut-down	min. 0.7 A
Output current with ground connection interrupt when switched off	max. 25 mA
Switching capacity	typ. 100 mW (In the case of ground connection interrupt; at 1 kΩ load resistance)
Inrush current	max. 1.5 A (for 20 ms)
Overload protection, short-circuit protection of outputs	Zener diode in output chip The four channels are thermally coupled, i.e. an error in one channel can also influence the other channels.

Programming Data

ID code (hex)	BD
ID code (dec.)	189
Length code (hex)	41
Length code (dec.)	65
Process data channel	4 Bit
Input address area	0 Bit
Output address area	4 Bit
Parameter channel (PCP)	0 Bit
Register length (bus)	4 Bit



For the programming data/configuration data of other bus systems, please refer to the corresponding electronic device data sheet (e.g., GSD, EDS).

Fieldbus data telegram

Fieldbus system	PROFIBUS DP
Required parameter data	3 Byte
Need for configuration data	4 Byte

Error messages to the higher level control or computer system

Short-circuit / overload of the digital outputs	Error message in the diagnostic code (bus) and display (2 Hz) via the LED (D) on the module
---	---

Electrical isolation/isolation of the voltage areas**Test section**

7.5 V supply (bus logics)/24 V supply (I/O)

Test voltage

500 V AC, 50 Hz, 1 min

7.5 V supply (bus logics) / functional earth ground

500 V AC, 50 Hz, 1 min

24 V supply (I/O) / functional earth ground

500 V AC, 50 Hz, 1 min



To achieve electrical isolation between the logic level and the I/O area, supply these areas from separate power supply units. Interconnection of the power supply units in the 24 V area is not permitted (see also user manual).

Approvals

For the latest approvals, please visit phoenixcontact.net/products.

5 Additional tables**5.1 Output characteristic curve****Output characteristic curve when switched on (typical)**

Output current (A)	Differential output voltage (V)
0	0
0.1	0.04
0.2	0.08
0.3	0.12
0.4	0.16
0.5	0.20

5.2 Power dissipation**Formula for calculating the power dissipation of the electronics**

$$P_{EL} = 0,19 \text{ W} + \sum_{i=1}^n (0,10 \text{ W} + I_{Li}^2 \times 0,40 \Omega)$$

Where:

P_{EL} Total power dissipation in the terminal

i Continuous index

n Number of outputs set ($n = 1 \dots 4$)

I_{Li} Load current of output i

Power dissipation of the housing

Maximum 0.6 W (within the permissible operating temperature)

5.3 Limitation of simultaneity, derating

Ambient temperature T_{amb}	Maximum load current		
	100 % simultaneity	75 % simultaneity	50 % simultaneity
$\leq 35 \text{ }^\circ\text{C}$	0.5 A	0.5 A	0.5 A
$\leq 45 \text{ }^\circ\text{C}$	0.375 A	0.5 A	0.5 A
$\leq 55 \text{ }^\circ\text{C}$	0.25 A	0.33 A	0.5 A

At 100 % simultaneity, a load current of 0.5 A per channel is permissible within the ambient temperature range up to 35 °C, a load current of 0.375 A in the range from 35 °C to 45 °C and a load current of 0.25 A in the range from 45 °C to 55 °C.

If a maximum of two channels are operated in the permissible ambient temperature range (50 % simultaneity), a load current of 0.5 A may be tapped.

If all channels are used, the permissible working point must be defined according to the above-stated formula.



An example for calculating the working point can be found in the user manual IL SYS INST UM E.

6 Internal circuit diagram

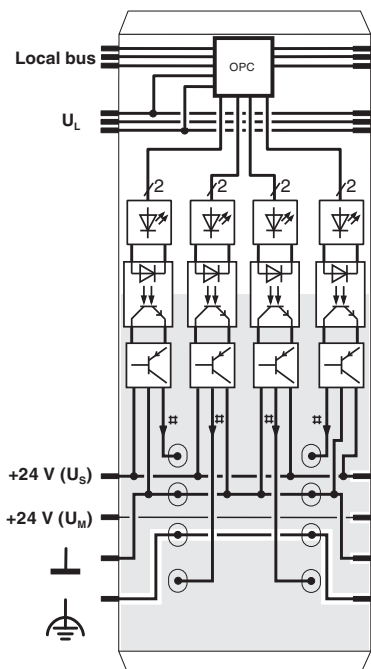





Figure 1 Internal wiring of the terminal points

Key:

 Protocol chip
(Bus logic including voltage conditioning)

 LED (status indicator)

 Optocoupler

 Transistor

 Digital output

 Electrically isolated area

 Explanation for other used symbols has been provided in the IL SYS INST UM E user manual.

7 Local status and diagnostic indicators

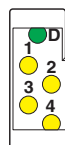

Figure 2 Local status and diagnostic indicators

Designation	Color	Meaning
D	Green	Diagnostics (bus and logic voltage)
1 ... 4	Yellow	Status of the outputs

8 Terminal point assignment

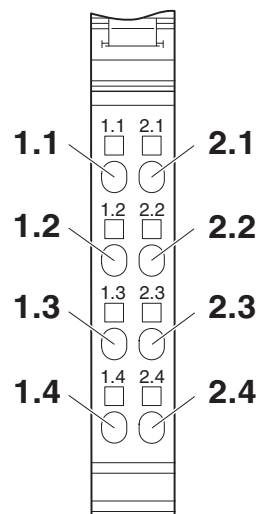

Figure 3 Terminal point assignment

Terminal point	Assignment
1.1 / 2.1	Signal output (OUT 1 / OUT 2)
1.2 / 2.2	Ground contact (GND) for 2 and 3-wire connection
1.3 / 2.3	FE connection for 3-wire connection
1.4 / 2.4	Signal output (OUT 3 / OUT 4)

9 Connection notes and examples



When connecting the actuators, observe the assignment of the terminal points to the process data.



NOTE: Malfunction
GND of the actuators and GND of the supply voltage U_S , which supply the actuators, must have the same potential.

The simplest way to meet this requirement is to use the IB IL PD GND-PAC terminal. Wire the GND connections for the actuators to these terminals. In this way, they are connected with the potential jumper GND of the Inline station.

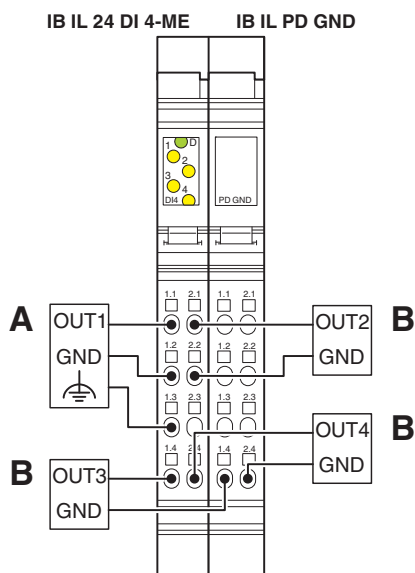

Figure 4 Typical connection of actuators when using the IB IL PD GND-PAC terminal

- A 3-wire termination
- B 2-wire termination

The actuators can also be connected via external busbars. Ensure that GND of the actuators and GND for U_S have the same potential.

When using external power rails, make sure that the ground (GND) has a reference to the Inline system ground.

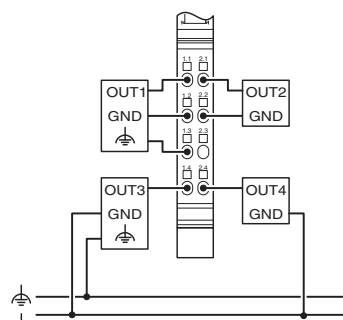

Figure 5 Typical connection of actuators when using external busbars

10 Process data

Assignment of the terminal points to the output process data

(Byte.Bit) view	Byte.Bit	0.3	0.2	0.1	0.0
Assignment	Terminal point (signal)	2.4	1.4	2.1	1.1
	Terminal point (GND)	-	-	2.2	1.2
	Terminal point (FE)	-	-	2.3	1.3
Status indicator	LED	4	3	2	1



For the assignment of the illustrated (byte.bit) view to your INTERBUS control or computer system, please refer to the DB GB IBS SYS ADDRESS data sheet.



SCATTERGOOD & JOHNSON LTD

ELECTRICAL ENGINEERING & FLUID CONTROL DISTRIBUTORS

Est.1899

At Scattergood & Johnson Ltd, we pride ourselves on being a technical distributor to specialist industries.

Working with a range of quality product suppliers across a number of specialist markets, we are not your average 'box shifter' - we are your technical and supply chain partner.

We fully support every product we sell - for free! Our internal team and external sales engineers can answer any product or application question, no matter the complexity.

Backing up this technical ability is a range of 50,000+ products available from stock for nationwide next day delivery (same day if required!), or you can collect what you need from any of our trade counters around the UK.

Select your specialist interest below to learn more about how we can help.



Online, In Branch and On the Road - Scattergood & Johnson Ltd, there when you need us.

www.scatts.co.uk