

IB IL AO 2/U/BP-ME

Inline Terminal With Two Analog Voltage Outputs

Data Sheet 703800

04/2004

5660001

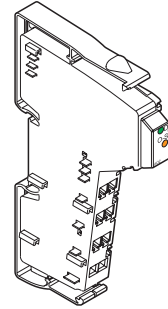

This data sheet is only valid in association with the user manual for your bus system, see "Ordering Data" on page 30.

Function

The terminal is designed for use within an Inline station. It is used to output analog voltage signals.

Features

- Two analog signal outputs
- Connection of actuators in 2-wire technology
- Voltage ranges:
-10 V to +10 V (13-bit resolution) and
0 V to +10 V (12-bit resolution)
- Output value data available in two formats (IB IL and IB ST)
- Parameterizable behavior of the outputs in the event of an error
- Process data update including conversion time of the digital-to-analog converter < 1 ms
- Diagnostic indicators

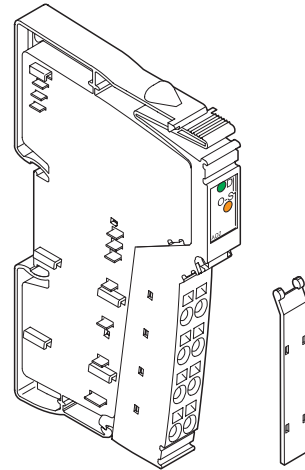

5660C007

Figure 1 IB IL AO 2/U/BP-ME terminal

Table of Contents

Function	1
Installation Instructions.....	4
Internal Circuit Diagram	5
Electrical Isolation	6
Connection Notes	6
Connection Example	7
Programming Data	7
Process Data Words	8
Formats for Representing the Output Values	12
Output Behavior	17
Input Behavior	19
Parameterization	21
Technical Data	23
Ordering Data.....	30

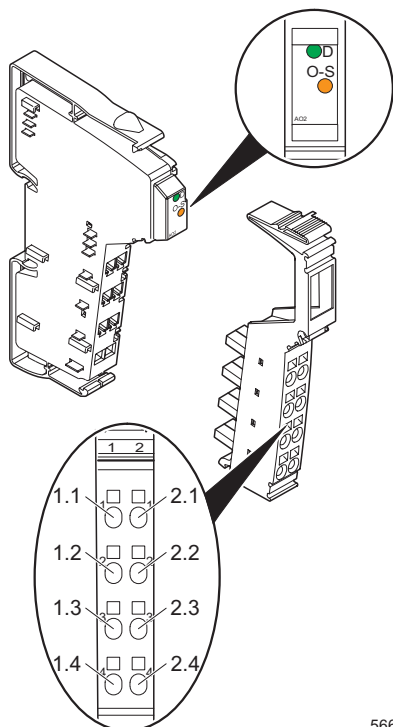

Figure 2 IB IL AO 2/U/BP-ME

5660C002

Local Diagnostic and Status Indicators

Des.	Color	Meaning
D	Green	Diagnostics
O-S	Orange	Original default state parameterized

Terminal Assignment

Terminal Point	Signal	Assignment
1.1	U1	Voltage output 1
2.1	U2	Voltage output 2
1.2, 2.2	–	Not used
1.3, 2.3	AGND	Voltage output ground
1.4, 2.4	Shield	Shield connection

Parameterized Default Upon Delivery

By default upon delivery, the parameters are set as follows:

- Data format: IB IL
- Behavior of the outputs in the event of an error: Outputs hold the last value (Hold)
- Output range: -10 V to +10 V

The following terminal parameters can be configured according to your conditions using the process data:

- Data format: IB ST
- Behavior of the outputs in the event of an error: Outputs are reset to 0 V (Reset)
- Output range: 0 V to +10 V



For parameterization you must switch to parameterization mode. The procedure is described in "Parameterization" on page 21.

Installation Instructions

High current flowing through the potential jumpers U_M and U_S leads to a temperature rise in the potential jumpers and the inside of the terminal. Observe the following instruction to keep the current flowing through the potential jumpers of the analog terminals as low as possible:

**Create a separate main circuit for the analog terminals.**

If this is not possible in your application and if you are using analog terminals in a main circuit together with other terminals, place the analog terminals behind all the other terminals at the end of the main circuit.

Note the derating curve shown on page 25.

Internal Circuit Diagram

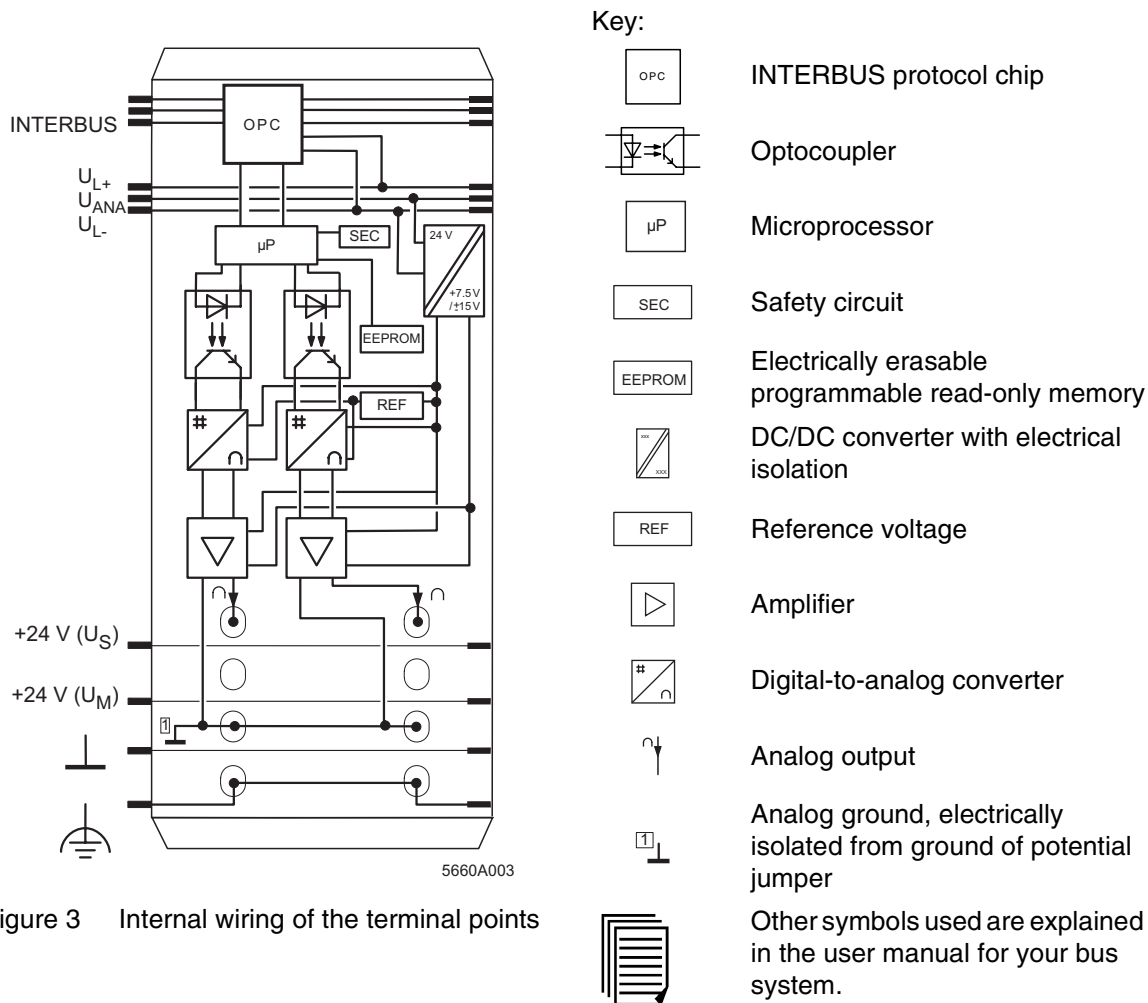

Figure 3 Internal wiring of the terminal points

Electrical Isolation

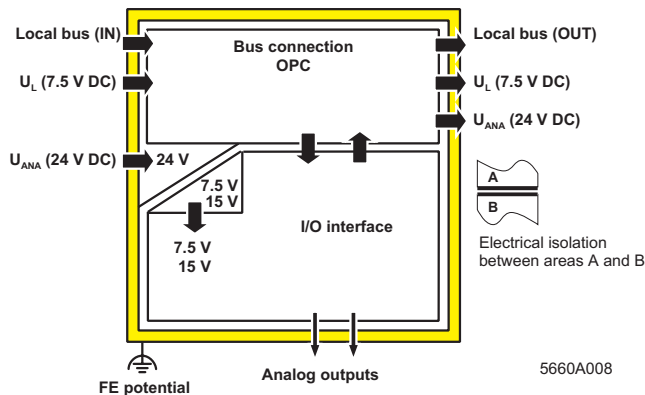

Figure 4 Electrical isolation of the single function areas

Connection Notes



Analog actuators with a cable length of **< 10 m (32.81 ft.)** can be connected using unshielded twisted-pair cables.



Connect analog actuators with a cable length of **> 10 m (32.81 ft.)** using shielded twisted-pair cables.

Connect one end of the shielding to PE protective earth ground. Fold the outer cable sheath back and connect the shield to the terminal via the contacts 1.4 or 2.4. These contacts connect the shield directly to FE (functional earth ground) on the terminal side.

Connection Example

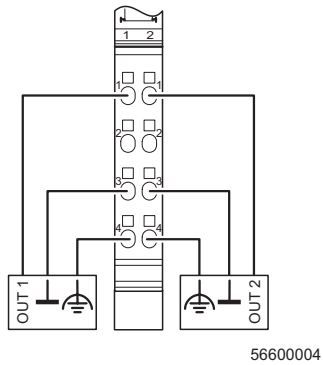

Figure 5 Connection of two voltage actuators with shield connection using 2-wire technology

Programming Data/ Configuration Data

INTERBUS

ID code	5B _{hex} (91 _{dec})
Length code	02 _{hex}
Process data channel	32 bits
Input address area	4 bytes
Output address area	4 bytes
Parameter channel (PCP)	0 bytes
Register length (bus)	4 bytes

Other Bus Systems



For the programming data/
configuration data of other bus
systems, please refer to the
corresponding electronic device data
sheet (GSD, EDS).

IB IL AO 2/U/BP-ME

Process Data Words

Assignment of the Terminal Points to the OUT Process Data Words

(Word.bit) view	Byte	Word 0															
	Bit	15	14	13	12	11	10	9	8	7	6	5	4	3	2	1	0
(Byte.bit) view	Byte	Byte 0								Byte 1							
	Bit	7	6	5	4	3	2	1	0	7	6	5	4	3	2	1	0
Assignment	IB IL format	SB	Channel 1 output value											0	0	0	
Assignment	IB ST format	SB	Channel 1 output value											0	0	0	
Terminal points	Signal	Terminal point 1.1: voltage output 1															
	Signal reference	Terminal point 1.3															
	Shielding (FE)	Terminal point 1.4															

(Word.bit) view	Byte	Word 1															
	Bit	15	14	13	12	11	10	9	8	7	6	5	4	3	2	1	0
(Byte.bit) view	Byte	Byte 2								Byte 3							
	Bit	7	6	5	4	3	2	1	0	7	6	5	4	3	2	1	0
Assignment	IB IL format	SB	Channel 2 output value											0	0	0	
Assignment	IB ST format	SB	Channel 2 output value											0	0	0	
Terminal points	Signal	Terminal point 2.1: voltage output 2															
	Signal reference	Terminal point 2.3															
	Shielding (FE)	Terminal point 2.4															

SB Sign bit

0 Bits 2 through 0 are irrelevant. Set these bits to "0".

Assignment of the IN Process Data Words

(Word.bit) view	Byte	Word 0															
	Bit	15	14	13	12	11	10	9	8	7	6	5	4	3	2	1	0
(Byte.bit) view	Byte	Byte 0								Byte 1							
	Bit	7	6	5	4	3	2	1	0	7	6	5	4	3	2	1	0
Assignment		SB	Mirrored channel 1 output value												F	R	H

(Word.bit) view	Byte	Word 1															
	Bit	15	14	13	12	11	10	9	8	7	6	5	4	3	2	1	0
(Byte.bit) view	Byte	Byte 2								Byte 3							
	Bit	7	6	5	4	3	2	1	0	7	6	5	4	3	2	1	0
Assignment		SB	Mirrored channel 2 output value												F	R	H

- SB Sign bit
 F Output data format
 R Voltage range
 H Hold/reset

IB IL AO 2/U/BP-ME

OUT Process Data Words

The OUT process data words specify the output values in each cycle.

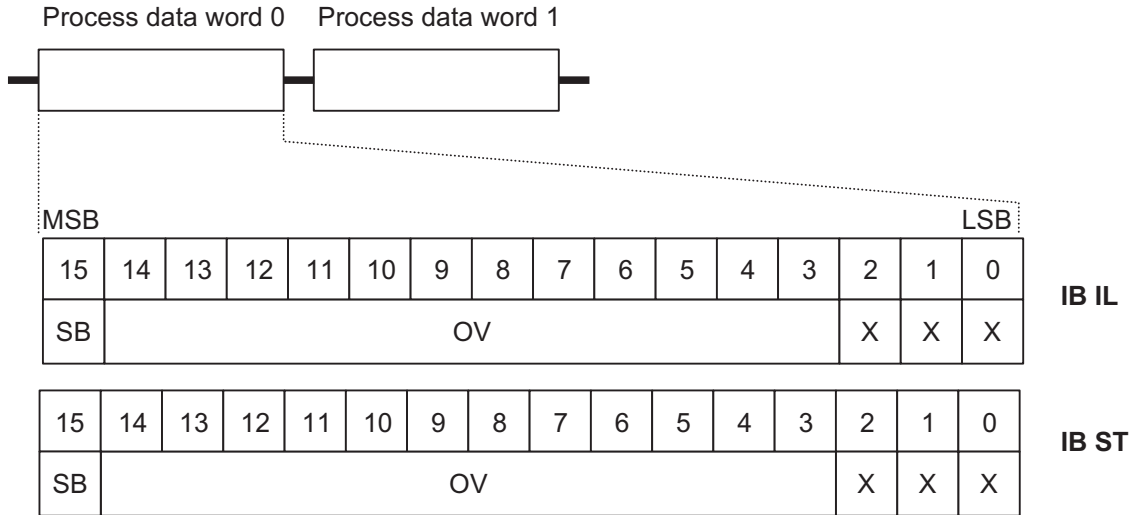

5660A006

Figure 6 OUT Process data words in IB IL and IB ST formats

- SB Sign bit
- OV Output value
- X Irrelevant bit
- MSB Most significant bit
- LSB Least significant bit



Set the irrelevant bits to 0.

IN Process Data Words

Bits 15 through 3 of the OUT process data words are mirrored in the IN process data words. Bit 15 is the sign bit. Bits 2 through 0 are available as status bits. They contain information about the parameterized behavior of the terminal.

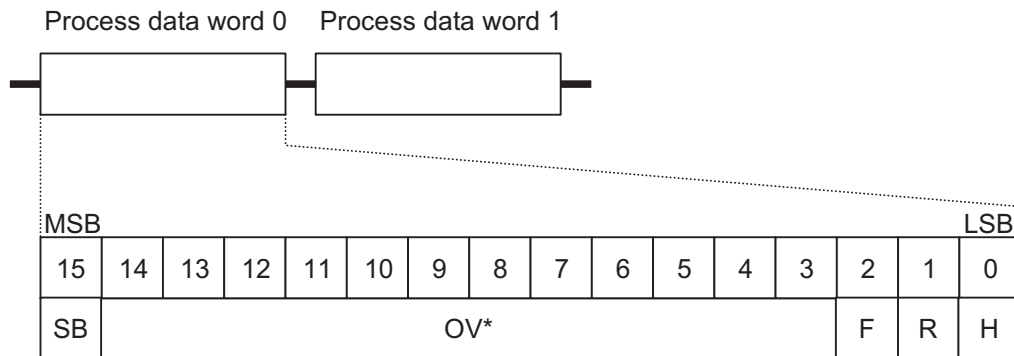

56600010

Figure 7 IN process data words

SB	Sign bit
OV*	Mirrored output value
F	Output data format
R	Voltage range
H	Hold/reset
MSB	Most significant bit
LSB	Least significant bit

Bits 2 through 0 have the following meaning:

Bit	Designation	Meaning	Bit x = 0	Bit x = 1
2	F	Output data format	IL	ST
1	R	Voltage range	-10 V to +10 V	0 V to +10 V
0	H	Hold/reset	Hold	0

IB IL AO 2/U/BP-ME**Formats for Representing the Output Values**

"IB IL" is the default format on the terminal. To ensure that the terminal can be operated in previously used ST data formats, the output value representation can be switched to "IB ST" format.

"IB IL" Format

The output value is represented in bits 14 through 3. An additional bit (bit 15) is available as a sign bit.

15	14	13	12	11	10	9	8	7	6	5	4	3	2	1	0
SB	OV												0	0	0

5660B016

Figure 8 Output value representation in "IB IL" format (12 bits + sign bit)

SB Sign bit
OV Output value

Significant Output Values in "IB IL" Format

The IB IL 24 AO 2 /U/BP terminal has two analog output channels that can supply voltages from -10 V to +10 V with a 13-bit resolution.

Output range -10 V to +10 V

Output Data Word (Two's Complement)		-10 V to +10 V U_{Output}	Remark
hex	dec	V	
<7FFF	32767	+10.837	
>7F00	32512	+10.837	
7F00	32512	+10.837	
7530	30000	+10.0	
0008	8	+2.667 mV	Smallest DAC quantization step
0000	0	0	
FFF8	-8	-2.667 mV	
8AD0	-30000	-10.0	
8100	-32512	-10.837	
<8100	<i>Processed separately:</i>		
8001	-32767	+10.837	(Overrange)
8080	-32640	-10.837	(Underrange)
80xx	(Other)	Hold last value	

IB IL AO 2/U/BP-ME

Output range 0 V to 10 V

Output Data Word (Two's Complement)		0 V to 10 V U_{Output}	Remark
hex	dec	V	
≤ 7FFF	32512	+10.837	
> 7500	32512	+10.837	
7F00	32512	+10.837	
7530	30000	+10.0	
0008	8	+2.667 mV	Smallest DAC quantization step
< 0000	0	0	
< 8100	<i>Processed separately:</i>		
8001	-32767	+10.837	(Overrange)
8080	-32640	0	(Underrange)
80xx	(Other)	Hold last value	



The 80xx_{hex} range is reserved exclusively for error and message codes.

"IB ST" Format

The output value is represented in bits 14 through 3. Bit 15 is available as sign bit. Bits 2 through 0 are irrelevant.

This format corresponds to the data format used on INTERBUS ST modules.

15	14	13	12	11	10	9	8	7	6	5	4	3	2	1	0
SB	OV											X	X	X	

56600011

Figure 9 Output value representation in "IB ST" format (12 bits + sign bit)

- SB Sign bit
- OV Output value
- X Irrelevant bit (Set this bit to 0.)

IB IL AO 2/U/BP-ME

Significant Output Values in "IB ST" Format

Output range 0 V to 10 V

Output Data Word (Two's Complement)	0 V to 10 V U_{Output}
hex	V
>7FF8	9.9975
7FF8	9.9975
4000	5.0
0008	0.002441
< 0000	0

Output range -10 V to +10 V

Output Data Word (Two's Complement)	-10 V to +10 V U_{Output}
hex	V
>7FF8	9.9975
7FF8	9.9975
0008	0.002441
0000	0
FFF8	-0.002441
8008	-9.9975
< 8008	-9.9975

Output Behavior

Output Behavior During Error-Free Operation (Normal Operation)

On power up during normal operation, the output range and the data format are read using the terminal EEPROM (non-volatile).

Volatile parameterization is also possible for these settings as well as for the behavior of the terminal in the event of an error. This parameterization can be carried out during runtime by a process data sequence.

Output Behavior in the Event of an Error

In the event of an error the outputs behave as set in the EEPROM (non-volatile) or as subsequently parameterized (volatile). This means that the outputs hold the last value (HOLD, default setting) or are reset to 0 (RESET, can be parameterized).

Output Behavior of the Voltage Output



Take output behavior (in the event of an error) into account when configuring your system!

Switching Operation/ State of the Supply Voltage	Marginal Condition	INTERBUS OUT Process Data Word (Hexadecimal)	Behavior/Status of the Analog Output
U_{ANA} from 0 V to 24 V	$U_L = 0$ V	xxxx	0 V
U_{ANA} from 24 V to 0 V	$U_L = 7.5$ V	xxxx	0 V
Bus in Stop	$U_{ANA} = 0$ V	xxxx	0 V
Bus in Stop	$U_{ANA} = 24$ V	xxxx	Hold last value
Bus reset (e.g., remote bus cable break)		xxxx	Hold last value (default setting) or 0 V (can be parameterized)

U_{ANA} Analog supply voltage of the terminal

U_L Supply voltage of the module electronics (communications power)

xxxx Any value in the range from 0000_{hex} to FFFF_{hex}

IB IL AO 2/U/BP-ME

Response of the Control System or the Computer to a Hardware Signal for Different Control or Computer Systems

Signal	Control or Computer System	Status After the Switching Operation	
		INTERBUS OUT Process Data Word (Hexadecimal)	Analog Output
			U_{out}
NORM*	AEG Schneider Automation	0000	0 V
BASP	Siemens S5	0000	0 V
CLAB	Bosch	0000	0 V
SYSFAIL	VME	0000	0 V
SYSFAIL	PC	0000	0 V
CLEAR OUT	Moeller IPC	0000	0 V

* On controller boards for AEG Schneider Automation control systems it is possible to set the NORM signal so that the OUT process data word and the analog output maintain the last value.

Response of the Voltage Output to a Control Command From the INTERBUS Controller Board

Command	Status After the Switching Operation	
	OUT Process Data Word (Hexadecimal)	Analog Output
		U_{out}
STOP	xxxx	Hold last value
ALARM-STOP (reset)	xxxx	Hold last value (default setting) or 0 V (can be parameterized)

Input Behavior

When analyzing the input behavior, a distinction is made between normal operation and parameterization mode. Input behavior in parameterization mode is described in "Parameterization" on page 21.

During **error-free normal operation**, the output data is mirrored in the input words as "acknowledgment" in bits 15 through 3 as soon as it is transmitted to the DAC.

Bits 2 through 0 are available as status bits and are used to display and read the set behavior of the terminal.

As the IB IL AO 2/U/BP-ME terminal only evaluates bits 15 through 3 as data bits in both the IB IL and IB ST format, only these 13 bits are mirrored in the input data word (see notes on error codes, overranges and underranges).

15	14	13	12	11	10	9	8	7	6	5	4	3	2	1	0
SB	OV*											F	R	H	

56600014



Figure 10 Input data in "IB IL" and "IB ST" formats

SB	Sign bit		
OV*	Mirrored output value		
F	Data format	0: IB IL	1: IB ST
R	Output range	0: -10 V to +10 V	1: 0 V to 10 V
H	Hold/reset	0: Hold	1: Reset

If an **error** is detected by the terminal, it is indicated by an error code in the first IN process data word. Possible error codes can be found in the following table.

IB IL AO 2/U/BP-ME

Error Codes:

Input Data Word (Two's Complement)	Cause	Remedy
hex		
8010	 <p>This code can only appear in parameterization mode and can have two causes:</p>	
	<p>1 Configuration is carried out</p>  <p>In step 2 of parameterization, this code appears after sending the code 8055_{hex} in the first input word. It does not indicate an error at this point.</p>	Continue configuration
	<p>2 Configuration invalid</p>	Check parameterization
8020	<p>DAC voltage falls below the permissible value</p>  <p>I/O error is triggered.</p>	<p>Check the bus terminal voltage supply; Check that the potential jumpers are connecting safely; Replace the terminal</p>
8040	Terminal faulty	Replace the terminal



The error codes overwrite the status bits (bits 2 through 0) with "0". This means that in IB ST data format, it is also possible to clearly distinguish valid process data.

Parameterization

By default upon delivery, the terminal parameters are set as follows:

Data format:	IB IL
Behavior of the outputs in the event of an error:	Outputs hold the last value (Hold)
Output range:	-10 V to +10 V

You can configure the following terminal parameters according to your conditions, using the process data:

Data format:	IB ST
Behavior of the outputs in the event of an error:	Outputs are reset to 0 (Reset)
Output range:	0 V to +10 V

In order to parameterize the terminal you must change to parameterization mode. In the first process data output word, transmit codes 8033_{hex} and 8055_{hex} one after the other.



In order not to change accidentally to parameterization mode, you should set bits 2 through 0 to 0 in normal operation when transmitting process data.



The parameterization is valid for both channels.

Parameterizing the Terminal:

<p>Step 1:</p>	<p>Transmission of code 8033_{hex} in the first OUT process data word.</p> <p>In bits 15 through 3 of the first IN process data word this code is acknowledged as a normal process data item.</p> <div data-bbox="327 1107 431 1164" data-label="Image"> </div> <div data-bbox="445 1107 1295 1211" data-label="Text"> <p>For every subsequent code which is not equal to 8055_{hex} in the first process data word, normal operation continues and the code is interpreted as a process data item.</p> </div>
<p>Step 2:</p>	<p>Transmission of code 8055_{hex} in the first OUT process data word.</p> <p>Acknowledgment takes place via code 8010_{hex} in the first input word.</p> <p>In this case, this code does not indicate an error, but shows that a configuration word is eventually expected (in step 3).</p> <div data-bbox="327 1442 431 1499" data-label="Image"> </div> <div data-bbox="445 1442 1295 1512" data-label="Text"> <p>For every subsequent code that is not equal to 80xx_{hex} in the first process data word, parameterization mode is quit.</p> </div>



IB IL AO 2/U/BP-ME

Step 3:	<p>Transmission of the parameterization code: $1000\ 0000\ 1000\ p_3p_2p_1$_{bin}.</p> <p>Where p_x are the terminal parameters: p_3: Data format (0: IB IL; 1: IB ST) p_2: Output range (0: -10 V to +10 V; 1: 0 V to 10 V) p_1: Reset behavior (0: Hold; 1: Reset)</p> <p>Acceptance of the value is confirmed in bits 15 through 0 of the first input word through mirroring of the code. If an invalid configuration is displayed, code 8010_{hex} appears in the first input data word, which indicates the error "Invalid Configuration".</p> <p>This step can be repeated as often as you like.</p> <div data-bbox="281 552 385 614" style="display: inline-block; vertical-align: middle;"></div> <div data-bbox="400 552 1246 661" style="border: 1px solid black; background-color: #ffff00; padding: 5px; display: inline-block; vertical-align: middle;"> <p>If a code that is not equal to $80xx_{hex}$ is transmitted in the first process data word, parameterization mode is quit without the parameterization taking effect.</p> </div>
Step 4:	<p>In this step you specify whether the parameterization stored in the EEPROM is volatile (dynamic) or non-volatile (static).</p> <div data-bbox="259 765 1260 881" style="border: 1px solid black; padding: 5px;"> <p>Volatile parameterization: After a power up this setting is no longer available. Subsequent operation uses the settings stored in the EEPROM. Transmission of code 8077_{hex}.</p> </div> <div data-bbox="259 881 1260 998" style="border: 1px solid black; padding: 5px;"> <p>Non-volatile parameterization: The parameterization is stored in the EEPROM. After a power up this parameterization from the EEPROM is used. Transmission of code 8099_{hex}.</p> </div> <p>After writing 8077_{hex} or 8099_{hex} the parameterization takes effect and parameterization mode is quit. This is displayed in the first input word through mirroring of code 8077_{hex} or 8099_{hex}. These values have a dedicated acknowledgment function. Only the next process data item is processed as normal.</p>



If parameterization was aborted, it is possible to switch to parameterization mode by restarting with step 1. The orange "O-S" LED on the terminal indicates whether the original configuration is present or if the current configuration differs from the default configuration of the terminal upon delivery. The LED is on if the default state is parameterized.

Technical Data

General Data	
Order Designation	IB IL AO 2/U/BP-ME
Order No.	28 63 95 7
Housing dimensions (width x height x depth)	12.2 mm x 120 mm x 71.5 mm (0.480 x 4.724 x 2.815 in.)
Weight	48 g (without connectors)
Operating mode	Process data mode with 2 words
Type of actuator connection	2-wire technology
Permissible temperature (operation)	-25°C to +55°C (-13°F to +131°F)
Permissible temperature (storage/transport)	-25°C to +85°C (-13°F to +185°F)
Permissible humidity (operation)	75% on average, 85% occasionally
	In the range from -25°C to +55°C (-13°F to +131°F) appropriate measures against increased humidity (> 85%) must be taken.
Permissible humidity (storage/transport)	75% on average, 85% occasionally
	For a short period, slight condensation may appear on the outside of the housing if, for example, the terminal is brought into a closed room from a vehicle.
Permissible air pressure (operation)	80 kPa to 106 kPa (up to 2000 m [6562 ft.] above sea level)
Permissible air pressure (storage/transport)	70 kPa to 106 kPa (up to 3000 m [9843 ft.] above sea level)
Degree of protection	IP20 according to IEC 60529
Class of protection	Class 3 according to VDE 0106, IEC 60536
Interface	
INTERBUS interface	Data routing

IB IL AO 2/U/BP-ME

Power Consumption	
Communications power U_L	7.5 V
Current consumption from U_L	Approximately 33 mA, typical; 40 mA, maximum
I/O supply voltage U_{ANA}	24 V DC
Current consumption at U_{ANA}	
No-load operation ($R_L > 10 \text{ M}\Omega$)	18 mA, typical; 28 mA, maximum
Full load operation ($R_L = 2 \text{ k}\Omega$)	25 mA, typical; 35 mA, maximum
Total power consumption	
No-load operation ($R_L > 10 \text{ M}\Omega$)	0.68 W, typical
Full load operation ($R_L = 2 \text{ k}\Omega$)	0.85 W, typical

Supply of the Module Electronics and I/O Through the Bus Terminal/Power Terminal	
Connection method	Potential routing

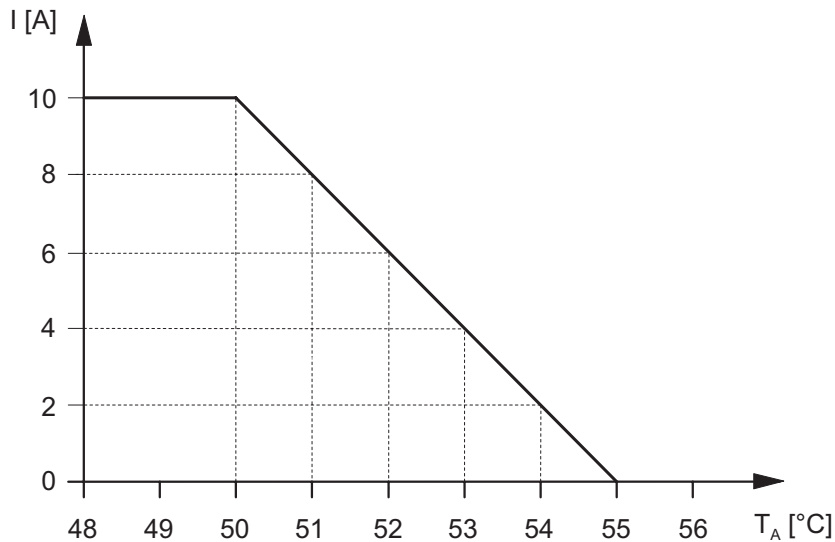
Derating: Permissible Ambient Temperature Depending on the Current of the Potential Jumpers U_M and U_S (Total Current)

56600012

Above $T_A = +50^\circ\text{C}$ (122°F) the derating is 2 A/K.

 T_A

Ambient temperature in °C

I

Current flowing through potential jumpers U_M and U_S (in A)

IB IL AO 2/U/BP-ME

Analog Outputs	
Number	2
Signal connection method	2-wire technology, single-ended
Signals/calculated resolution in the process data word (calculated quantization per LSB)	
Voltage -10 V to +10 V	333.33 μ V/LSB
Voltage 0 V to +10 V	333.33 μ V/LSB
Representation of output value	
-10 V to +10 V	13-bit two's complement
0 V to +10 V	13-bit two's complement
 For the representation of the output value in the different formats, please refer to the notes in "Formats for Representing the Output Values" on page 12.	
Smallest DAC quantization step	
-10 V to +10 V	2.667 mV (13 bits)
0 V to +10 V	2.667 mV (12 bits)
Basic error limit	$\pm 0.02\%$, typical, of the output range final value
Output load	2 k Ω , minimum
Process data update time including the conversion time of the digital-to-analog converter	1 INTERBUS cycle (depending on the bus configuration); <1 ms
Signal rise time (slew rate)	
10% to 90% of the final value	15 μ s, typical
0% to > 99% of the final value	31 μ s, typical
Signal rise time (slew rate) (-9.0 V to + 9.0 V)	
No-load operation	0.35 V/ μ s, typical
With ohmic load ($R_L = 2$ k Ω)	0.24 V/ μ s, typical
With ohmic/capacitive load $R_L = 2$ k Ω / $C_L = 10$ nF	0.24 V/ μ s, typical
With ohmic/capacitive load $R_L = 2$ k Ω / $C_L = 220$ nF	0.09 V/ μ s, typical

Analog Outputs (Continued)	
Transient protection of analog outputs	Yes
Maximum cable length for the LiYCY (TP) cable type, (shielded twisted power station cable)	500 m (1640.42 ft.)
Electrical features of LiYCY (TP)	N x 2 x 0.5 (N= number of wire pairs, wire cross-section $\geq 0.5 \text{ mm}^2$ (20 AWG))
Inductance	0.67 mH/km, typical
Effective capacitance	120 nF/km, typical

Tolerance Behavior and Temperature Response (Absolute Tolerance Values) (The tolerance values refer to the output range final value of 10 V.)		
	Typical	Maximum
Tolerance at 23°C (73.4°F)		
Total offset voltage	±1.0 mV	±8.0 mV
Gain error	±2.5 mV	±12.0 mV
Differential non-linearity	±1.5 mV	±5.0 mV
Total tolerance at 23°C (73.4°F)	±5.0 mV	±25.0 mV
Temperature response at -25°C to +55°C (-13°F to +131°F)		
Offset voltage drift T_{KVO}	±2.1 mV	±5.0 mV
Gain drift T_{KG}	±9.2 mV	±20.0 mV
Total voltage drift $T_{Ktot} = T_{KVO} + T_{KG}$	±11.3 mV	±25.0 mV
Total tolerance of the voltage output (-25°C to +55°C [-13°F to +131°F]) offset error + gain error + linearity error + drift error	±15.6 mV	±50.0 mV

IB IL AO 2/U/BP-ME

Tolerance Behavior and Temperature Response (Relative Tolerance Values) (The tolerance values refer to the output range final value of 10 V.)		
	Typical	Maximum
Tolerance at 23°C (73.4°F)		
Total offset voltage	±0.010%	±0.027%
Gain error	±0.025%	±0.060%
Differential non-linearity	±0.015%	±0.027%
Total tolerance at 23°C (73.4°F)	±0.09%	±0.25%
Temperature response at -25°C to +55°C (-13°F to +131°F)		
Offset voltage drift T_{KVO}	4 ppm/K	10 ppm/K
Gain drift T_{KG}	18 ppm/K	40 ppm/K
Total voltage drift $T_{Ktot} = T_{KVO} + T_{KG}$	23 ppm/K	50 ppm/K
Total tolerance of the voltage output (-25°C to +55°C [-13°F to +131°F]) offset error + gain error + linearity error + drift error	±0.16%	±0.50%

Additional Tolerances Influenced by Electromagnetic Fields		
Type of Electromagnetic Interference	Typical Deviation from the Output Range Final Value (Voltage Output)	
	Relative	Absolute
Electromagnetic fields; field strength 10 V/m according to EN 61000-4-3/ IEC 61000-4-3	< ±0.2%	< ±20 mV
Conducted interference Class 3 (test voltage 10 V) according to EN 61000-4-6/ IEC 61000-4-6	< ±2.8%	< ±280 mV

The values are valid for shielded and unshielded twisted actuator cables.

Safety Equipment	
Transient protection of analog outputs	Yes

Electrical Isolation/Isolation of the Voltage Areas

The electrical isolation of the logic level from the I/O area is ensured through the DC/DC converter.

Common Potentials

24 V I/O voltage, 24 V segment voltage, and GND have the same potential. FE is a separate potential area.

Separate Potentials in the System Consisting of Bus Terminal/Power Terminal and I/O Terminal

- Test Distance	- Test Voltage
7.5 V supply (bus logic), 24 V supply U_{ANA} / I/O	500 V AC, 50 Hz, 1 min
7.5 V supply (bus logic), 24 V supply U_{ANA} /functional earth ground	500 V AC, 50 Hz, 1 min
24 V supply (I/O) / functional earth ground	500 V AC, 50 Hz, 1 min

Error Messages to the Higher-Level Control or Computer System

Failure of or falling below communications power U_L	Yes, I/O error message to the bus terminal
--	--

IB IL AO 2/U/BP-ME

Ordering Data

Description	Order Designation	Order No.
Terminal with two analog voltage outputs, including I/O connector and labeling field	IB IL AO 2/U/BP-ME	28 63 95 7
 <p>As an option, you can connect the shield using the shield connector which is available as an accessory.</p>		
Connector with six spring-cage connections and shield connection (green, w/o color print); pack of 5	IB IL SCN-6-SHIELD-TWIN	27 40 24 5
"Configuring and Installing the INTERBUS Inline Product Range" user manual	IB IL SYS PRO UM E	27 43 04 8



Make sure you always use the latest documentation. It can be downloaded at www.phoenixcontact.com.

Phoenix Contact GmbH & Co. KG
 Flachsmarktstr. 8
 32825 Blomberg
 Germany



+ 49 - (0) 52 35 - 3-00



+ 49 - (0) 52 35 - 3-4 12 00



www.phoenixcontact.com



Worldwide Locations:

www.phoenixcontact.com/salesnetwork



SCATTERGOOD & JOHNSON LTD

ELECTRICAL ENGINEERING & FLUID CONTROL DISTRIBUTORS

Est.1899

At Scattergood & Johnson Ltd, we pride ourselves on being a technical distributor to specialist industries.

Working with a range of quality product suppliers across a number of specialist markets, we are not your average 'box shifter' - we are your technical and supply chain partner.

We fully support every product we sell - for free! Our internal team and external sales engineers can answer any product or application question, no matter the complexity.

Backing up this technical ability is a range of 50,000+ products available from stock for nationwide next day delivery (same day if required!), or you can collect what you need from any of our trade counters around the UK.

Select your specialist interest below to learn more about how we can help.

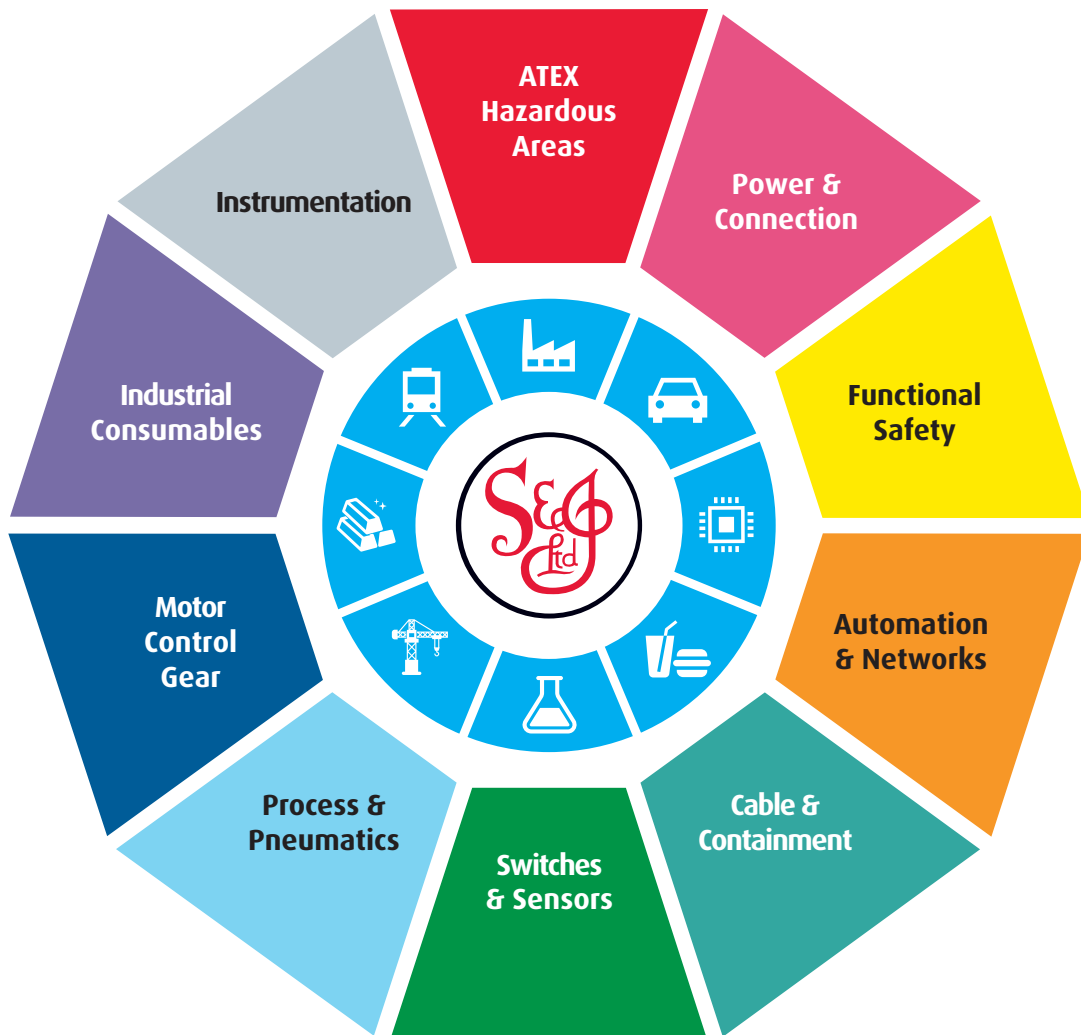

Online, In Branch and On the Road - Scattergood & Johnson Ltd, there when you need us.

www.scatts.co.uk