

IB IL SGI 2/F-PAC

**Inline analog strain gauge input terminal,
2 fast inputs, 4, 6-wire connection method**

Data sheet
7210_en_06

© PHOENIX CONTACT 2018-05-16

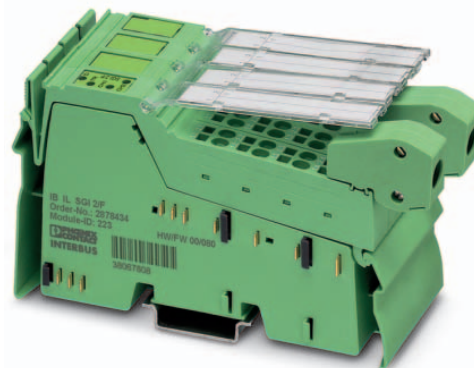

1 Description

The terminal is designed for use within an Inline station. This terminal is a fast input module used to connect load cells, force transducers, mass pressure transducers, and similar devices based on strain gauges.

The strain gauges can be connected using 6 or 4-wire technology.

The strain gauge output signals are measured in each bus cycle and updated in the process data (bus-synchronous process data update).

The terminal is suitable for control applications with increased speed requirements.

There are two options for data exchange:

- Via process data (both inputs in one bus cycle)
- via PCP Compact (both inputs in the "Analog Values" PCP object) The measured values are represented by standardized 16-bit values.

The measured values are represented by standardized 16-bit values.

Features

- 2 fast inputs for strain gauge
- Connection of the strain gauges with 6- and 4-wire technology
- Sensor supply voltage provided by the terminal, no external power supply required
- Communication either via process data or parameter channel (PCP Compact)
- Channels are parameterized independently of one another via the bus system
- Bus-synchronous process data update

Valid from firmware version 1.10.



A short circuit in the strain gauge supply at one of the two channels also prevents measured data acquisition at the other channel for the duration of the short circuit.



This data sheet is only valid in association with the IL SYS INST UM E user manual.



Make sure you always use the latest documentation. It can be downloaded from the product at [phoenixcontact.net/products](https://www.phoenixcontact.net/products).

2	Table of contents	
1	Description	1
2	Table of contents	2
3	Ordering data	3
4	Technical data	4
5	Additional tables	7
6	Internal circuit diagram	8
7	Terminal point assignment.....	9
8	Electrical isolation.....	9
9	Installation instructions	10
10	Connection notes	10
11	Connection examples	10
	11.1 6-wire connection (one strain gauge load cell per channel).....	11
	11.2 6-wire connection (several strain gauge load cells per channel).....	12
	11.3 4-wire connection	13
	11.4 Permissible nominal characteristic values according to the jumper supply.....	13
12	Local diagnostic indicators	14
13	Process data.....	15
14	OUT process data words	15
	14.1 Output word OUT0 (control word)	15
	14.2 Output words OUT1 and OUT2 (parameter words).....	16
15	Process data input words IN	17
	15.1 Input word IN0 (status word).....	17
	15.2 Input words IN1 and IN2	17
16	PCP communication	19
	16.1 General information.....	19
	16.2 Object dictionary for PCP communication	19
17	PCP object description	20
	17.1 "Config Table" object	20
	17.2 "Analog Values" object.....	21
18	Startup and measuring jumper detuning.....	21
19	Parameterization and analog values.....	21

3 Ordering data

Description	Type	Order No.	Pcs./Pkt.
Inline analog strain gauge input terminal, complete with accessories (connector and labeling field), 2 fast inputs, 4, 6-wire connection method	IB IL SGI 2/F-PAC	2878638	1
Inline analog strain gauge input terminal, complete with accessories (connector and labeling field), transmission speed 2 Mbaud, 2 quick inputs, 4, 6-wire connection method	IB IL SGI 2/F-2MBD-PAC	2878735	1
Accessories	Type	Order No.	Pcs./Pkt.
Inline shield connector (Connector/Adapter)	IB IL SCN-6 SHIELD	2726353	5
Connector, for digital 1, 2 or 8-channel Inline terminals (Connector/Adapter)	IB IL SCN-8	2726337	10
Shield connection clamp, for shield on busbars, contact resistance < 1 mΩ (Assembly)	SK 8	3025163	10
Shield connection clamp, for shield on busbars, contact resistance < 1 mΩ (Assembly)	SK 14	3025176	10
Shield connection clamp, for shield on busbars, contact resistance < 1 mΩ (Assembly)	SK 20	3025189	10
Shield connection clamp, for shield on busbars, contact resistance < 1 mΩ (Assembly)	SK 35	3026463	10
Support bracket for busbars (Assembly)	AB-SK	3025341	10
Support bracket, Bracket for busbars, set every 20 cm, length: 95.5 mm, width: 6.2 mm, number of positions: 1, color: gray (Assembly)	AB-SK 65	3026489	10
Support bracket, Bracket for busbars, set every 20 cm, length: 10 mm, width: 56 mm, height: 20 mm, number of positions: 2, color: silver (Assembly)	AB-SK/E	3026476	10
Neutral busbar, width: 10 mm, height: 3 mm, DIN VDE 0611-4: 1991-02, material: Copper, tin-plated, length: 1000 mm, color: silver (Assembly)	NLS-CU 3/10 SN 1000MM	0402174	10
Connection terminal block, connection method: Screw connection, load current: 41 A, cross section: 0.5 mm ² - 6 mm ² , width: 7 mm, color: silver	AK 4	0404017	50
Connection terminal block, connection method: Screw connection, load current: 41 A, cross section: 0.5 mm ² - 6 mm ² , width: 7 mm, color: green-yellow	AKG 4 GNYE	0421029	50
Connection terminal block, connection method: Screw connection, load current: 41 A, cross section: 0.5 mm ² - 6 mm ² , width: 7 mm, color: black	AKG 4 BK	0421032	50
Software CD for FDT container for integrating device DTMs (free download)	AX+ BASIC	2985068	1
DTM library	AX DTM LIB	2988065	1

Documentation	Type	Order No.	Pcs./Pkt.
User manual, English, Automation terminals of the Inline product range	IL SYS INST UM E	-	-
User manual, English, Porting using PCP compact	IBS PCP COMPACT UM E	-	-

4 Technical data

Dimensions (nominal sizes in mm)

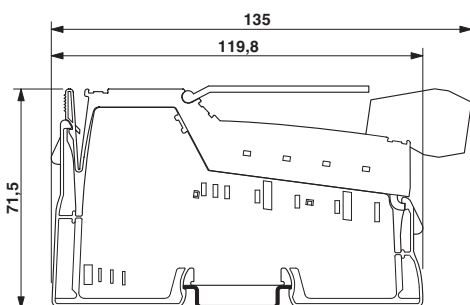

Width	48.8 mm
Height	136 mm
Depth	71.5 mm

General data

Color	green
Weight	190 g
Operating mode	Process data operation with 3 words, PCP with 1 word
Ambient temperature (operation)	-25 °C ... 55 °C
Ambient temperature (storage/transport)	-25 °C ... 85 °C
Permissible humidity (operation)	10 % ... 95 % (non-condensing)
Permissible humidity (storage/transport)	10 % ... 95 % (non-condensing)
Air pressure (operation)	70 kPa ... 106 kPa (up to 3000 m above sea level)
Air pressure (storage/transport)	70 kPa ... 106 kPa (up to 3000 m above sea level)
Degree of protection	IP20
Protection class	III, IEC 61140, EN 61140, VDE 0140-1

Connection data: Inline connector

Connection method	Spring-cage connection
Conductor cross section solid / stranded	0.08 mm ² ... 1.5 mm ² / 0.08 mm ² ... 1.5 mm ²
Conductor cross section [AWG]	28 ... 16
Stripping length	8 mm

Connection data for UL approvals: Inline connector

Connection method	Spring-cage connection
Conductor cross section solid / stranded	0.2 mm ² ... 1.5 mm ² / 0.2 mm ² ... 1.5 mm ²
Conductor cross section [AWG]	24 ... 16
Stripping length	8 mm

Interface: Inline local bus

Number	2
Connection method	Inline data jumper
Transmission physics	Copper

Transmission speed Inline local bus

IB IL SGI 2/F-PAC	500 kbps
IB IL SGI 2/F-2MBD-PAC	2 Mbps

Communications power U_L (500 kbps)

Supply voltage	7.5 V DC (via voltage jumper)
Current draw	typ. 75 mA max. 85 mA

Communications power U_L (2 Mbps)

Supply voltage	7.5 V DC (via voltage jumper)
Current draw	typ. 100 mA max. 110 mA

Supply of analog modules U_{ANA}

Supply voltage	24 V DC (via voltage jumper)
Supply voltage range	19.2 V DC ... 30 V DC (including all tolerances, including ripple)
Current draw	typ. 8 mA (without strain gauge) typ. 32 mA (with maximum load of 58.3 Ω when $U_V = 5$ V)

Power consumption

Power consumption	typ. 0.76 W (Device in nominal operation)
-------------------	---

Voltage output

Number of outputs	2
Impedance	> 58.3 Ω (typical; permissible total resistance of the strain gauge)
Output voltage	5 V, 3.3 V
Output current	typ. 55 mA (with $U_V = 3.3$ V) typ. 85 mA (with $U_V = 5$ V)

Input channels for strain gauge	
Number of inputs	2
Connection technology	6 or 4-wire, twisted pair shielded cable
Characteristics	+1 mV/V, +2 mV/V, +3 mV/V, +4 mV/V ±1 mV/V, ±2 mV/V, ±3 mV/V, ±4 mV/V
Bridge difference U_d	Measuring range specified by selecting the characteristic and the bridge voltage
Bridge voltage U_0	3.3 V 5 V
Measured value representation	15 bit + sign bit
Process data update	1 x per local bus cycle at a bus cycle time ≥ 1 ms
Limit frequency	typ. 1.6 kHz (Of the bridge difference input)

Programming data (INTERBUS, local bus)	
ID code (hex)	DF
ID code (dec.)	223
Length code (hex)	03
Length code (dec.)	03
Process data channel	48 Bit
Input address area	6 Byte
Output address area	6 Byte
Parameter channel (PCP)	2 Byte
Register length (bus)	64 Bit

Configuration and parameter data in a PROFIBUS system	
Required parameter data	15 Byte
Required configuration data	5 Byte

Error messages to the higher level control or computer system	
Failure of the power supply at U_{ANA}	Error message in the process data
Failure of or insufficient communications power U_L	I/O error message sent to the bus coupler
Peripheral fault	Error message in the process data

Electrical isolation/isolation of the voltage areas	
Test section	Test voltage
Logic/analog I/O (digital isolator)	500 V AC, 50 Hz, 1 min.
Functional earth ground/analog I/O (isolating distance)	500 V AC, 50 Hz, 1 min.
Logic/functional earth ground (isolating distance)	500 V AC, 50 Hz, 1 min.

Approvals
For the latest approvals, please visit phoenixcontact.net/products.

5 Additional tables

Tolerances at $T_A = +25^\circ\text{C}$			
Nominal characteristic value		Relative deviation in % related to the measuring range final value	
		typical	maximum
Unipolar	1 mV/V, 2 mV/V, 3 mV/V, 4 mV/V	$\pm 0.01\%$	$\pm 0.3\%$
Bipolar	± 1 mV/V, ± 2 mV/V, ± 3 mV/V, ± 4 mV/V	$\pm 0.2\%$	$\pm 0.6\%$

The typical values contain the typical offset error, gain error, and linearity error in the respective parameterization relating to the positive measuring range up to 100% of the nominal characteristic value.

This data is valid for nominal operation (preferred mounting position, $U_S = 24$ V) with set 16-sample mean value.

The maximum tolerance values represent the worst case measurement inaccuracy. Besides the maximum offset error, the gain error and the linearity error, the maximum tolerance values also comprise the longtime drift as well as the maximum tolerances of the test and calibration equipment.

Please also observe the values for temperature drift and the tolerances under influences of electromagnetic interferences.

This data is valid for at least twelve months.

Additional tolerances influenced by electromagnetic fields	
Type of electromagnetic interference	Typical deviation in % related to the measuring range final value
Electromagnetic fields; field strength 10 V/m according to EN 61000-4-3/ IEC 61000-4-3	$< \pm 0.7\%$
Conducted interference, Class 3 (10 V test voltage) according to EN 61000-4-6/ IEC 61000-4-6	$< \pm 0.2\%$

Additional tolerances influenced by electromagnetic fields

Type of electromagnetic interference	Typical deviation in % related to the measuring range final value
--------------------------------------	---

Fast transients (burst) up to an interference voltage of ± 2.2 kV in acc. with EN 61000-4-4 / IEC 61000-4-4

You can minimize interference by connecting the sensor cable shield to the DIN rail in front of the terminal via a shield connection terminal block (see ordering data, accessories).

Temperature and drift response ($T_A = -25^\circ\text{C} \dots +55^\circ\text{C}$)

		Relative drift in ppm/K related to the measuring range final value	
		typical	maximum
Unipolar	1 mV/V, 2 mV/V, 3 mV/V, 4 mV/V	15 ppm/K	50 ppm/K
Bipolar	± 1 mV/V, ± 2 mV/V, ± 3 mV/V, ± 4 mV/V	500 ppm/K	980 ppm/K

The typical value contains the typical offset and gain drift in the respective parameterization in the temperature range from -25°C up to $+55^\circ\text{C}$ relating to the positive measuring range up to 100% of the nominal characteristic value.

This data is valid for nominal operation (preferred mounting position, $U_S = 24$ V) with set 16-sample mean value.

The maximum tolerance values represent the worst case measurement inaccuracy. Besides maximum offset and gain drift, they also comprise longtime drift as well as the maximum tolerances of the test and calibration equipment.

6 Internal circuit diagram

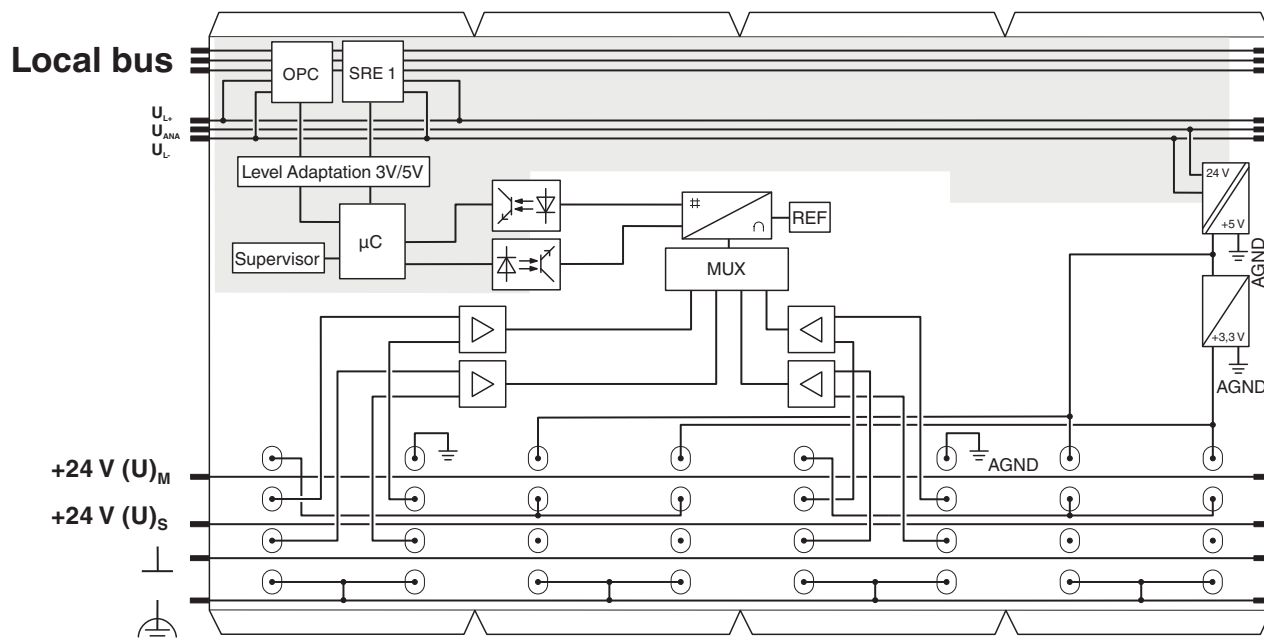















Figure 1 Internal wiring of the terminal points

Key:

	Protocol chip		Multiplexer
	Register expansion		DC/DC converter
	Level adaptation		DC/DC converter with electrical isolation
	Hardware monitoring		Electrically isolated area
	Microcontroller		Please refer to the IL SYS INST UM E user manual for an explanation of other symbols used.
	Optocoupler		
	Analog/digital converter		
	Reference voltage source		
	Amplifier		

7 Terminal point assignment

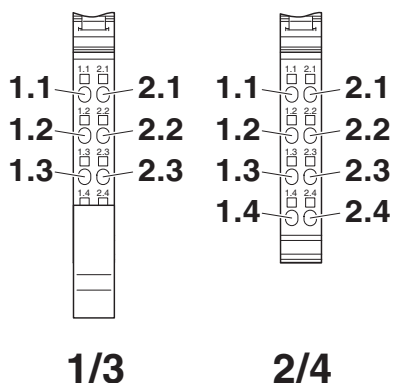

Figure 2 Terminal point assignment

Terminal point	Signal	Assignment
Connector 1		
1.1 / 2.1	+U _{V1} / GND _{UV}	Jumper supply U _{V1}
1.2 / 2.2	+U ₀₁ / -U ₀₁	Jumper voltage U ₀₁
1.3 / 2.3	+U _{d1} / -U _{d1}	Jumper difference U _{d1}
1.4 / 2.4	FE	Shield connection
Connector 2		
1.1 / 2.1	5 V / 3.3 V	Optional voltage for jumper supply
1.2 / 2.2	+U _{V1}	Routing the selected supply voltage to connection "Jumper supply U _{V1} " at connector 1
1.3 / 2.3	-	Not used
1.4 / 2.4	FE	Shield connection
Connector 3		
1.1 / 2.1	+U _{V2} / GND _{UV}	Jumper supply U _{V2}
1.2 / 2.2	+U ₀₂ / -U ₀₂	Jumper voltage U ₀₂
1.3 / 2.3	+U _{d2} / -U _{d2}	Jumper difference U _{d2}
1.4 / 2.4	FE	Shield connection
Connector 4		
1.1 / 2.1	5 V / 3.3 V	Optional voltage for jumper supply
1.2 / 2.2	+U _{V2}	Routing the selected supply voltage for the "Jumper supply U _{V2} " connection on connector 3
1.3 / 2.3	-	Not used
1.4 / 2.4	FE	Shield connection



Connect the terminal point of the selected voltage for the jumper supply to terminal point +U_{V1} on connector 2. Terminal points +U_{V1} on slot 2 are connected internally to terminal point +U_{V1} on slot 1 (see "Internal basic circuit diagram"). Therefore, the selected voltage at +U_{V1} is available on slot 1 (see also "Connection examples"). The same applies for terminal points +U_{V2} on slots 3 and 4.



Since no standard definition exists for the designation of the sensor cables, the designation specified in the table may differ from the sensor manufacturer's designation.

Example:

Jumper voltage (U₀) = sense input U_S
 Jumper difference (U_d) = signal or output

8 Electrical isolation

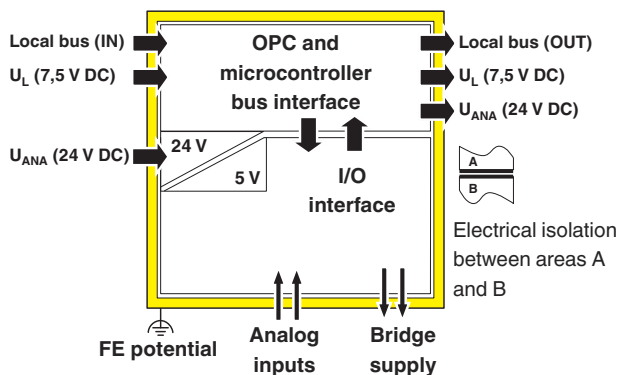

Figure 3 Electrical isolation of the individual function areas

9 Installation instructions

High current flowing through potential jumpers U_M and U_S leads to a temperature rise in the potential jumpers and inside the terminal. To keep the current flowing through the potential jumpers of the analog terminals as low as possible, always place the analog terminals after all the other terminals at the end of the main circuit (for the sequence of the Inline terminals: see also IL SYS INST UM E user manual).

10 Connection notes

Connecting the strain gauges



Connect the strain gauges using shielded twisted pair cables.

Connecting the shield



Only connect the shield at one point, preferably at the terminal. If the shield is securely connected to the sensor, insulate the shield on the terminal side.

Unused channels



Note the procedure for parameterizing unused channels. See description for bit 15 in OUT1 and OUT2.

11 Connection examples



The terminal can measure both unipolar and bipolar jumper differences. Observe the polarity when connecting $+U_d$ and $-U_d$.

If the analog terminal expects unipolar jumper differences, the signal excursion may be negative in the worst-case scenario. The measured value would therefore always be 0. In this case, adapt the signal excursion to the input voltage range by switching cables $+U_d$ and $-U_d$.

If the analog terminal is set to a bipolar jumper difference, the signal excursion may be mixed up in the sign bit in the worst-case scenario. In this case, adapt the signal excursion to the input voltage range again by switching cables $+U_d$ and $-U_d$.

Connections $+U_0$ and $-U_0$ are led back to a unipolar input. If the cables are mixed up, the terminal indicates a configuration error.

11.1 6-wire connection (one strain gauge load cell per channel)

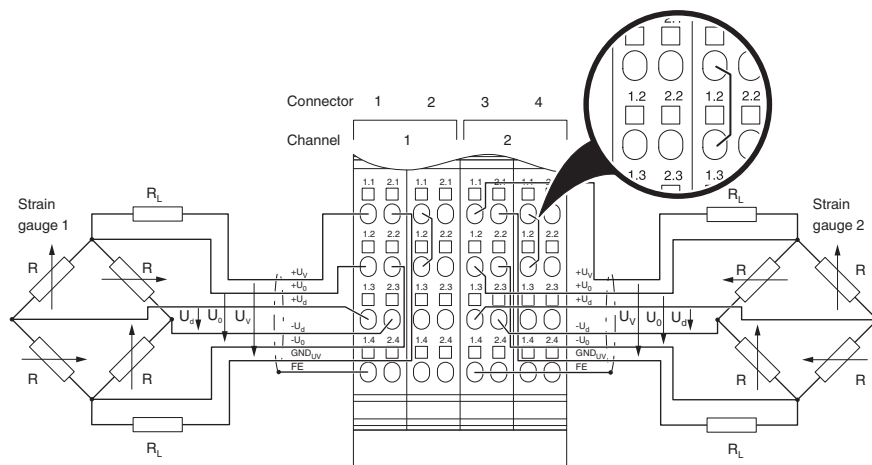

Figure 4 Connection of strain gauges in 6-wire technology

Key:

R_L : Cable resistance

Channel 1: connect the strain gauge to connector 1 in 6-wire technology.

At connector 2, select the jumper supply level. The terminal provides supply voltages of 5 V and 3.3 V. Connections $+U_{V1}$ of connector 1 and $+U_{V1}$ of connector 2 are connected internally. At connector 2, connect either 5 V or 3.3 V to $+U_{V1}$. This supplies the 6-wire connection of channel 1 with power.

Channel 2: connect the strain gauge to connector 3 in 6-wire technology.

At connector 4, select the jumper supply level. The terminal provides supply voltages of 5 V and 3.3 V. Connections $+U_{V2}$ of connector 3 and $+U_{V2}$ of connector 4 are connected internally. At connector 4, insert a wire jumper to connect either 5 V or 3.3 V to $+U_{V2}$. This supplies the 6-wire connection of channel 2 with power.



You can supply channels 1 and 2 with different supply voltages (5 V or 3.3 V).

11.2 6-wire connection (several strain gauge load cells per channel)

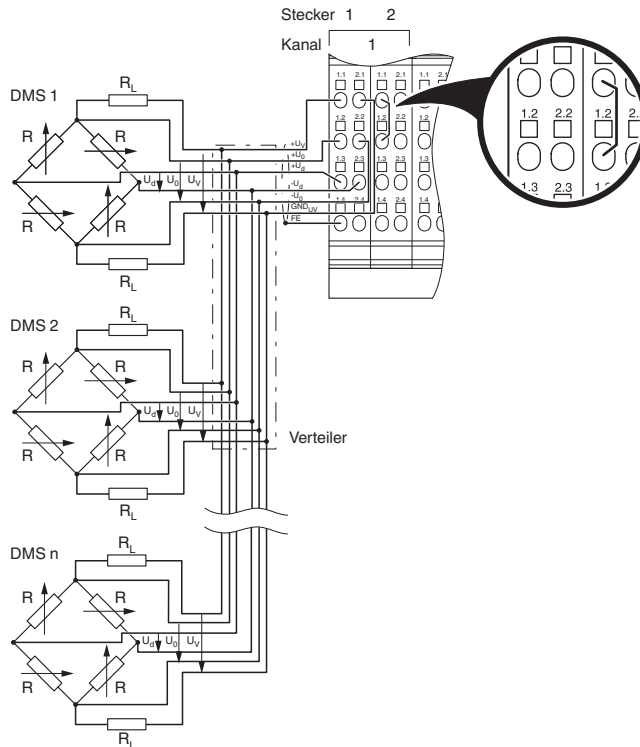

Figure 5 Connection of several strain gauges in 6-wire technology

Key:

R_L : Cable resistance



In this operating mode you can connect several strain gauge load cells parallel to connector 1 (channel 1) and/or connector 3 (channel 2), depending on the impedance of the type of strain gauge used.
Please note that the total impedance of the wired Inline terminal (channel 1 and channel 2) must not be lower than 58.3 Ω (typically).

Channel 2: connect the required number of strain gauges parallel to connector 3 in 6-wire technology.

At connector 4, select the jumper supply level. The terminal provides supply voltages of 5 V and 3.3 V. Connections $+U_{V2}$ of connector 3 and $+U_{V2}$ of connector 4 are connected internally. At connector 4, insert a wire jumper to connect either 5 V or 3.3 V to $+U_{V2}$. This supplies the 6-wire connection of channel 2 with power.



You can supply channels 1 and 2 with different supply voltages (5 V or 3.3 V).

Channel 1: connect the required number of strain gauges parallel to connector 1 in 6-wire technology.

At connector 2, select the jumper supply level. The terminal provides supply voltages of 5 V and 3.3 V. Connections $+U_{V1}$ of connector 1 and $+U_{V1}$ of connector 2 are connected internally. At connector 2, connect either 5 V or 3.3 V to $+U_{V1}$. This supplies the 6-wire connection of channel 1 with power.

11.3 4-wire connection

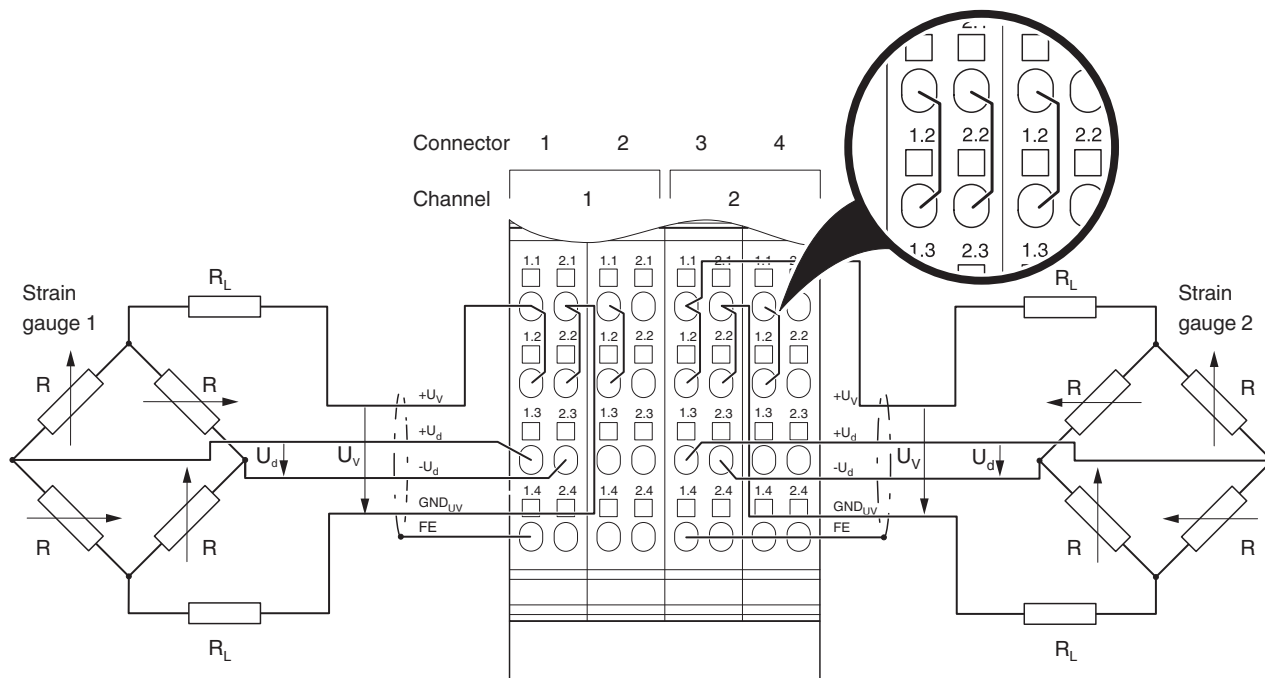

Figure 6 Connection of strain gauges in 4-wire technology (channel 1 and channel 2)

Key:

R_L : Cable resistance

Channel 1/channel 2: strain gauges can also be connected to the terminal in 4-wire technology.

In this case, for the channel in question (connector 1 and/or connector 3) connect connection $+U_V$ to $+U_0$ and connection GND_{UV} to $-U_0$ (shown magnified for channel 2).

The temperature and long-term drift compensation of the connecting cable is omitted in the case of the 4-wire technology.

11.4 Permissible nominal characteristic values according to the jumper supply

The table below indicates which nominal characteristic value can be parameterized for which jumper supply.

Nominal characteristic value	$U_V = 3.3\text{ V}$	$U_V = 5\text{ V}$
+1 mV/V	Yes	Yes
±1 mV/V	Yes	Yes
+2 mV/V	Yes	Yes
±2 mV/V	Yes	Yes
+3 mV/V	Yes	Yes
±3 mV/V	Yes	No
+4 mV/V	Yes	Yes
±4 mV/V	Yes	No

12 Local diagnostic indicators

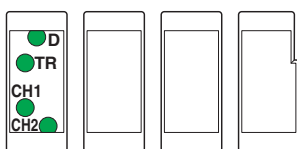

Figure 7 Local diagnostic indicators

Designation	Color	Meaning
D	green	Diagnostics (bus and logic voltage)
TR	green	PCP communication
CH 1	green	Diagnostics of channel 1
	green ON	Channel 1 is OK
	green OFF	Channel 1 not connected or not supplied or open circuit
CH 2	green	Diagnostics of channel 2
	green ON	Channel 2 is OK
	green OFF	Channel 2 not connected or not supplied or open circuit

Function identification

Green

2 Mbps: White stripe in the vicinity of the D LED

13 Process data

The terminal occupies three process data words and one PCP word.

Order of the process data words:

OUT0	OUT1	OUT2
Control word		

IN0	IN1	IN2
Status word		

14 OUT process data words

Three OUT process data words are available.

Parameterize the terminal using the process data output words.

Where:

- Output word OUT0 contains the command
- Output word OUT1 contains the parameters for channel 1
- Output word OUT2 contains the parameters for channel 2

The following parameterization options are available:

Parameterization	Short designation	Default
Selection of mean-value generation	Mean-value	No mean-value
Nominal characteristic value for calculating the gain (see "Startup/measuring jumper detuning")	Nominal characteristic value	±2 mV/V

Parameterization errors are indicated in the status word. The parameterization is only stored in a volatile memory.

If you change the parameterization, the message "Measured value invalid" appears (diagnostic code 8004_{hex}) until new measured values are available.

14.1 Output word OUT0 (control word)

		OUT0							
Bit	15 ... 8	7	6	5	4	3	2	1	0
Assignment	Command code	0	0	0	0	0	0	0	0

Bit 15 to bit 8 (command code):

Bit 15 ... bit 8	OUT0 (hex)	Command function
00000000	0000	Reading measured values
0001000C	1x00	Read parameterization in IN1 channel-by-channel C = channel number; 0 = channel 1, 1 = channel 2
00110000	3000	Read minimum value; IN1: Minimum value channel 1 IN2: Minimum value channel 2
00110001	3100	Read maximum value; IN1: Maximum value channel 1, IN2: Maximum value channel 2
00110010	3200	Delete minimum and maximum value of channel 1
00110011	3300	Delete minimum and maximum value of channel 2
00111100	3C00	Read firmware version and module ID in IN1.
01000000	4000	Parameterize device; parameterization for channel 1 in OUT1 and for channel 2 in OUT2



During the transient response (e.g., following a parameterization command), deviating measured values may exceed the minimum and maximum values. Therefore, at the start of acquisition delete the minimum and maximum values using command 3200_{hex} and/or 3300_{hex}. When deleted, the maximum and minimum value are set to 8004_{hex}. 8004_{hex} is the ID for an invalid measured value. As soon as the next measured value is available, it is applied as the minimum and maximum value.

One measurement is performed per bus cycle.

14.2 Output words OUT1 and OUT2 (parameter words)

For command word OUT0 = 4000_{hex}, specify the parameters in OUT1 and OUT2. These parameter words are only evaluated for this command.

		OUT1/OUT2															
Bit		15	14	13	12	11	10	9	8	7	6	5	4	3	2	1	0
Assignment	P	0	0	0	0	0	0	0	M	0	0	0	0				N

Where:

P	Parameterization	<p>If the bit is set, the channel in question is parameterized.</p> <p>If only one channel is used, there are two options available: Set bit 15 of the parameter word of the unused channel to 0. Or: Set bit 15 of the parameter word of the unused channel to 1 and parameterize the nominal characteristic value as "Channel inactive".</p>
M	Mean-value	<p>Selects mean-value generation. After every conversion, the measured value is saved in a mean-value memory via which the mean-value is generated. The memory size can be selected with the mean-value option. E.g., for a 16-sample mean-value, the mean-value is generated using the last 16 measured values.</p>
N	Nominal characteristic value	<p>Depending on the nominal characteristic value in relation to the jumper supply present, the terminal calculates the required gain for the parameterized input and therefore has the best possible resolution in the unipolar and bipolar area.</p> <p>If in the unipolar area the strain gauge is supplied with a load greater than 130% or a negative load, the jumper detuning is outside the measuring range and an error is triggered.</p> <p>If in the bipolar area the strain gauge is supplied with a load greater than 130% in the positive or negative direction, the jumper detuning is outside the measuring range and an error is triggered.</p>



Set all unused bits to 0.



If invalid parameters are specified in the parameter word, the command will not be executed. The command is acknowledged in the input words with the set error bit.

Parameter value ranges and presets

The values displayed in bold are pre-settings.

Bit 15:

Code		P: parameterization
dec	bin	
0	0	Channel is not parameterized
1	1	Channel is parameterized

Bit 8:

Code		M: Mean-value
dec	bin	
0	0	No mean-value
1	1	16-sample mean-value

Bit 3 ... bit 0:

Code		N: Nominal specific value
hex	bin	
0	0000	+1 mV/V
1	0001	±1 mV/V
2	0010	+2 mV/V
3	0011	±2 mV/V
4	0100	+3 mV/V
5	0101	±3 mV/V
6	0110	+4 mV/V
7	0111	±4 mV/V
F	1111	Channel inactive
Other		Reserved



Parameterize a channel to which no sensor is connected as inactive, otherwise error message 8002_{hex} (open circuit) will be output when the terminal is started up.



If a channel is parameterized as inactive, value 8004_{hex} (measured value invalid/no valid measured value available) is transmitted in the input data.

15 Process data input words IN

15.1 Input word IN0 (status word)

Input word IN0 performs the task of a status word.

		IN0								
Bit	15	14 ... 8	7	6	5	4	3	2	1	0
Assign-ment	EB	SP	0	0	0	0	0	0	0	0

EB: Error Bit

EB = 0 No error has occurred.

EB = 1 An error has occurred.

The error bit indicates whether a command could be executed without errors or not.

For the command code 4000_{hex} (parameterize device), a set error bit indicates an invalid parameterization. The following causes are possible:

- At least one of reserved bits is set.
- Parameterization via process data was disabled with parameterization via PCP via the “Config Table” object (“Parameterization via process data” system bit = 0).
Remedy: permit parameterization via process data (“Parameterization via process data” system bit = 1, see “Config Table object”).



If the channel is to be parameterized but the jumper voltage is not yet present, there is no error message for the parameterization command. The parameterization word is stored internally in the volatile memory. The process data contains error code 8002_{hex} for an open circuit.

As soon as the jumper voltage is within the valid range, the desired parameterization is carried out. The process data changes from 8002_{hex} to a valid measured value.

Please note that in this case the combination of nominal characteristic value code 5 or 7 with jumper voltage 5 V is not tested and an error message is therefore not generated in the event of this combination.

SP: Mirrored command code

A command code mirrored from the control word. Here, the MSB is suppressed.

15.2 Input words IN1 and IN2

The measured values, parameterization or firmware version are transmitted to the controller board or the computer via process data input words IN1 and IN2 according to the parameterization.

For control word 3C00_{hex}, word IN1 supplies the firmware version and the module ID.

The module ID for the terminal is 1_{hex}.

Example: Firmware version 1.23

		IN1															
Bit	15	14	13	12	11	10	9	8	7	6	5	4	3	2	1	0	
Assign-ment (hex)	1				2				3				1				
Meaning	Firmware version 1.23												Module ID				

Measured values

The measured values are available in IB IL format.

The measured value is represented in bits 14 to 0. An additional bit (bit 15) is available as a sign bit.

15	14	13	12	11	10	9	8	7	6	5	4	3	2	1	0
V	Analog value														

Bit 15 Most significant bit (MSB)

Bit 0 Least significant bit (LSB)

V Sign bit



Due to the fast measured value acquisition, there may be fluctuations in measured values in the four least significant bits.

The IB IL format supports extended diagnostics.
Values $>8000_{\text{hex}}$ and $<8100_{\text{hex}}$ indicate an error.

The following diagnostic codes are possible:

Code (hex)	Error
8001	Measuring range exceeded (overrange)
8002	Open circuit
8004	Measured value invalid or no valid measured value available
8020	Faulty supply voltage
8040	Device faulty
8080	Below measuring range (underrange)

Typical measured values:

Detuning in % of nominal value (%)		Input word (hex)	Input word (dec)
Bipolar	Unipolar		
> 130.048	> 130.048	8001	Overrange
$+130.048$	$+130.048$	7F00	32512
$+100.000$	$+100.000$	61A8	25000
$+1.000$	$+1.000$	00FA	250
$+0.004$	$+0.004$	0001	1
0.0	0.0	0000	0
-0.004	-	FFFF	-1
-100.000	-	9E58	-25000
-130.048	-	8100	-32512
< -130.048	-	8080	Underrange
-	-	8002	Open circuit

To calculate the detuning as a percentage for other measured values, please use the following formula:

Detuning = Process data value * 0.004 or

Detuning = Process data value/250

Example:

Nominal characteristic value ± 2 mV/V

Process data value 10000_{dec}

Detuning = $10000/250 = 40\%$

40% of 2 mV/V = 0.8 mV/V

16 PCP communication

PCP Compact is implemented on the terminal.

16.1 General information



For information on PCP communication, please refer to the user manual for PCP Compact (see ordering data).



The programs IBS CMD (for standard controller boards) and PC Worx (for Controllers (ILC), Field Controllers (FC) and Remote Field Controllers (RFC)) are available for the configuration and parameterization of your INTERBUS system. For additional information, please refer to the documentation of the software used.

On delivery, the terminal is parameterized according to the default settings (see "OUT process data output words"). The terminal can be parameterized to suit your application using process data or PCP.

During PCP operation you can parameterize the terminal using the "Config Table" object.

16.2 Object dictionary for PCP communication

Index	Data type	A	L	Meaning	Object name	Rights
0080 _{hex}	Array of Unsigned 16	4	2	Terminal parameterization	Config Table	rd/wr
0081 _{hex}	Array of Unsigned 16	2	2	Analog values of the channels	Analog Values	rd

A	Number of elements	rd	Read access permitted
L	Length of an element in bytes	wr	Write access permitted

17 PCP object description

17.1 "Config Table" object

Parameterize the terminal using this object.



If you parameterize the terminal via PCP and the "Parameterization via process data" bit in the "System bit" element equals 0, parameterization via process data is disabled. Set the bit to 1 in order to enable parameterization via process data in addition to parameterization via PCP.

Object description:

Object	Config Table	
Access	Read, write	
Data type	Array of Unsigned 16	4 x 2 bytes
Index	0080 _{hex}	
Subindex	00 _{hex}	Write all elements
	01 _{hex}	Parameterization of channel 1
	02 _{hex}	Parameterization of channel 2
	03 _{hex}	System bit
	04 _{hex}	Reserved
Length (bytes)	08 _{hex}	Subindex 00 _{hex}
	02 _{hex}	Subindex 01 _{hex} to 05 _{hex}
Data	Terminal parameterization	

Element value range

Parameterization of channel x

The "Parameterization of channel x" elements have the following structure:

Bit	15	14	13	12	11	10	9	8	7	6	5	4	3	2	1	0
Assignment	1	0	0	0	0	0	0	M	0	0	0	0			N	

Where:

- M Mean-value
- N Nominal characteristic value

For value ranges and default values, refer to "Output words OUT1 and OUT2 (parameter words)".

If you specify invalid parameters, a negative confirmation is generated with error message 08_{hex}, 00_{hex} or xx30_{hex}. The low byte of the Additional_Error_Code is 30_{hex} (value is out of range), the high byte contains the number of the element in question.

Example: Config Table is completely written with data (subindex 00) and the entry for channel 2 is invalid. In this case, the Additional_Error_Code is equal to 0230_{hex}.

System bit

The "System bit" element has the following structure:

Bit	15	14	13	12	11	10	9	8	7	6	5	4	3	2	1	0
Assignment	0	0	0	0	0	0	0	0	0	0	0	0	0	0	0	P

P: parameterization via process data

- Bit 0 = 0 If the terminal is parameterized via PCP, parameterization via process data is disabled (default).
- = 1 The terminal can always be parameterized via process data.

17.2 "Analog Values" object

The elements of this object contain the analog values of the channels in IB IL format.

Object description:

Object	Analog Values	
Access	Read	
Data type	Array of Unsigned 16	2 x 2 bytes
Index	0081 _{hex}	
Subindex	00 _{hex}	Read all elements
	01 _{hex}	Analog value of channel 1
	02 _{hex}	Analog value of channel 2
Length (bytes)	04 _{hex}	Subindex 00 _{hex}
	02 _{hex}	Subindex 01 _{hex} to 02 _{hex}
Data	Analog values of the channels	

18 Startup and measuring jumper detuning

To start the terminal, proceed as follows:

- Install the terminal within the Inline station.
To do so, proceed as described in the package slip.
- Connect the strain gauge in 6 or 4-wire technology (see "Connection examples").
- Supply power to the Inline station.
This power up parameterizes the terminal with the default values.
- If you do not wish to operate the terminal with the default values, parameterize the terminal via process data or PCP.
- Jumper detuning can now be measured.



Jumper detuning can only be measured if the corresponding input is parameterized. Jumper supply U_V must be present in order to parameterize the input.

19 Parameterization and analog values

Terminal parameterization is only required if you do not want to operate at least one of the channels with the default values.

You can parameterize the terminal via process data or via PCP and transmit the analog values accordingly.

If you have parameterized the terminal via PCP, you can enable subsequent parameterization via process data by setting the "Parameterization via process data" system bit to 1 (see "Config Table object").



For easy terminal parameterization, a function block can be downloaded at phoenixcontact.net/products.

Example 1: terminal parameterization via process data

A strain gauge pressure force transducer for control applications is connected to channel 1. Its data sheet specifies a characteristic of +2 mV/V at a nominal load of 500 N. Therefore parameterize channel 1 as follows:

Channel 1	
Nominal characteristic value	+2 mV/V
Mean-value	No mean-value
Parameter word OUT1	8002 _{hex}

A tractive and pressure force transducer with a characteristic of ± 4 mV/V at a nominal load of 1 kN is connected to channel 2. Therefore parameterize channel 2 as follows:

Channel 2	
Nominal characteristic value	± 4 mV/V
Mean-value	16-sample mean-value
Parameter word OUT2	8107 _{hex}



If both channels are operated with the default settings, parameterization is not required. When a parameterization command is sent, however, both channels will always be parameterized. Therefore also enter the corresponding parameterization for the channel that is to be operated with the default settings.
For example, if a "0" is transmitted for channel 1 in bit 15 (do not parameterize), the channel does not subsequently provide any values.

Step	Process data	Meaning
1	OUT2 = 8107 _{hex} OUT1 = 8002 _{hex} OUT0 = 4000 _{hex}	Specify parameterization
2	Wait until IN0 = 4000 _{hex}	Wait for confirmation
3	OUT0 = 0000 _{hex}	Request measured values
4	Wait until IN0 = 0000 _{hex}	Wait for confirmation
5	Measured value channel 1 = IN1 Measured value channel 2 = IN2	Reading measured values If the measured value = 80xx _{hex} , this corresponds to an error message.

Channel 1

Read measured value 5A78_{hex} (= 23160_{dez})
IN1

Current jumper detuning = IN1 x 0.004% x nominal characteristic value
= 23160 * 0.004 % * 2 mV/V
= 1.853 mV/V

Current load = IN1 x 0.004% x nominal load
= 23160 * 0.004 % * 500 N
= 463.2 N

Channel 2

Read measured value B422_{hex} (= 46114_{dec}); following evaluation of the MSB: -19422_{dec}
IN2

Current jumper detuning = IN2 x 0.004% x nominal characteristic value
= -19422 * 0.004 % * 4 mV/V
= -3.11 mV/V

Current load = IN2 x 0.004% x nominal load
= -19422 * 0.004 % * 1 kN
= -776.9 N

Example 2: MIN/MAX evaluation

The channel 1 and channel 2 pressure transducers are loaded and unloaded several times. Only the maximum load is of interest during the entire process.

Step	Process data	Meaning
1	OUT0 = 3200 _{hex}	Delete minimum and maximum values of channel 1
2	Wait until IN0 = 3200 _{hex}	Wait for confirmation
3	OUT0 = 3300 _{hex}	Delete minimum and maximum values of channel 2
4	Wait until IN0 = 3300 _{hex}	Wait for confirmation
5		Load and unload channel 1 and 2 pressure transducers
6	OUT0 = 3100 _{hex}	Read maximum values
7	Wait until IN0 = 3100 _{hex}	Wait for confirmation
8	Maximum value channel 1 = IN1 Maximum value channel 2 = IN2	Read maximum value; to calculate the current jumper detuning and the current load, see above. If the measured value = 80xx _{hex} , this corresponds to an error message.



SCATTERGOOD & JOHNSON LTD

ELECTRICAL ENGINEERING & FLUID CONTROL DISTRIBUTORS

Est.1899

At Scattergood & Johnson Ltd, we pride ourselves on being a technical distributor to specialist industries.

Working with a range of quality product suppliers across a number of specialist markets, we are not your average 'box shifter' - we are your technical and supply chain partner.

We fully support every product we sell - for free! Our internal team and external sales engineers can answer any product or application question, no matter the complexity.

Backing up this technical ability is a range of 50,000+ products available from stock for nationwide next day delivery (same day if required!), or you can collect what you need from any of our trade counters around the UK.

Select your specialist interest below to learn more about how we can help.

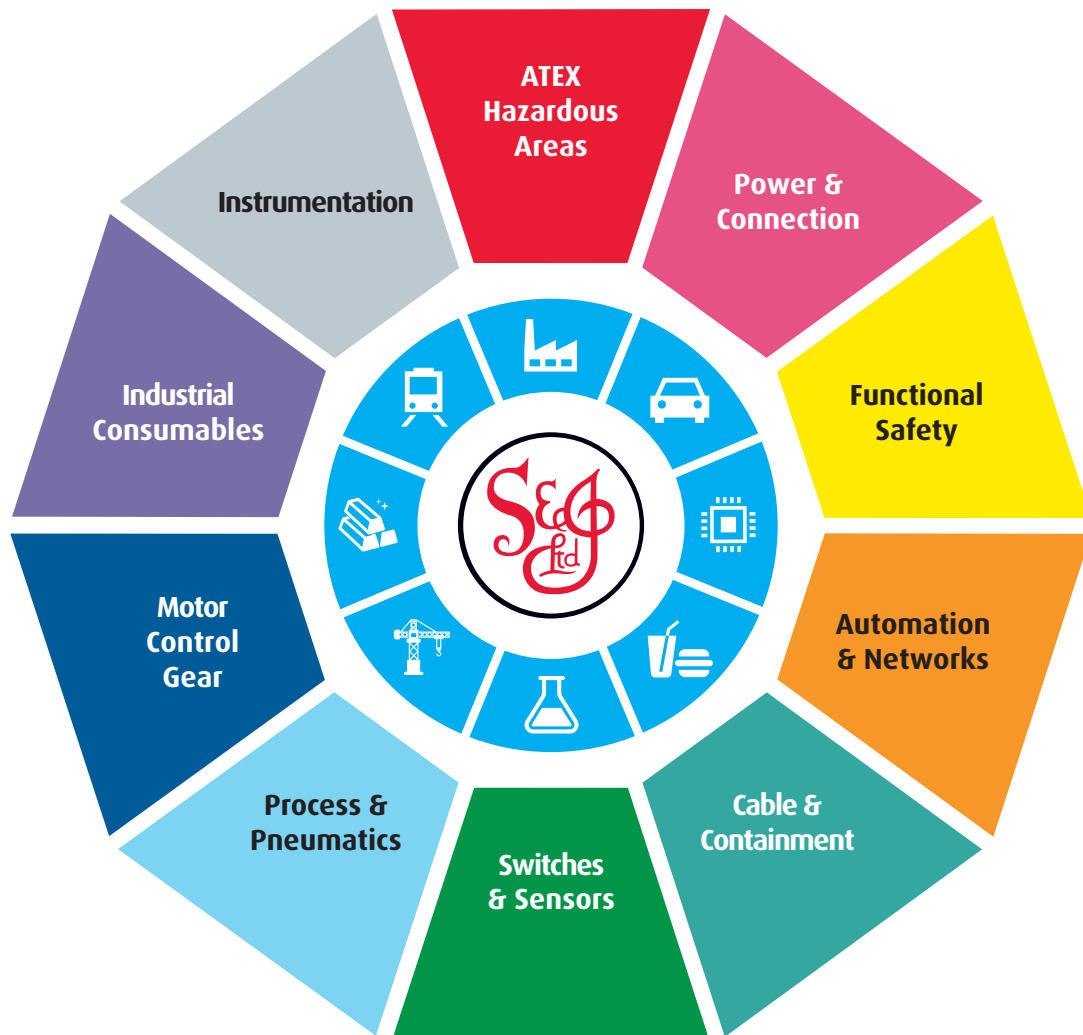

Online, In Branch and On the Road - Scattergood & Johnson Ltd, there when you need us.

www.scatts.co.uk