

FL IL 24 BK-PN-PAC

PROFINET IO/Inline Bus Coupler

AUTOMATIONWORX

Data Sheet

© PHOENIX CONTACT - 07/2005

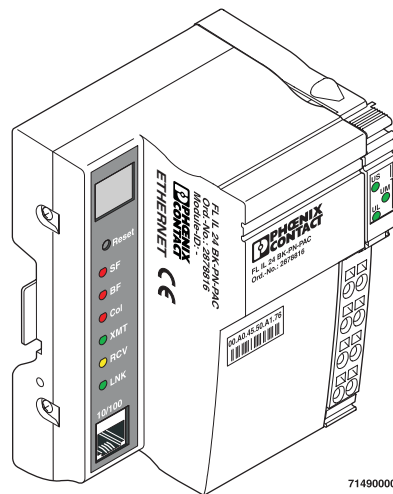

71490000

Description

PROFINET IO/Inline bus coupler

Features

- PROFINET IO/Inline bus coupler for the Inline I/O system
- Ethernet TCP/IP
 - 100BASE-TX
 - Management via SNMP
 - Integrated web server
- Up to 63 other Inline modules can be connected, of which a maximum of eight can be PCP devices
- Flexible installation system for Ethernet
- Representation of process data in the browser using XML
- Supported protocols: TCP/UDP, SNMPv2, TFTP and ICMP (Ping), PROFINET IO
- Comprehensive system diagnostics

Application

Connection of sensors/actuators via PROFINET.



Quick Start Guides for PC WorX 5 and Siemens S7 can be found in the Download Center at www.download.phoenixcontact.com.
 PC WorX: "Quick Start Guide PC WorX 5" (UM QS EN PC WORX 5, Order No. 26 99 86 2)
 Siemens S7: "Quick Start Guide STEP 7" (UM QS EN PROFINET PROXY IB, Order No. 26 99 99 8)



Make sure you always use the latest version of the GSDML file and the latest documentation for the module. The latest GSDML files and documentation can be found on the Internet at www.download.phoenixcontact.com in the Download Center.



Ensure that you are always working with the most recently published documentation. It can be downloaded at www.download.phoenixcontact.com.

A conversion table is available on the Internet at www.download.phoenixcontact.com/general/7000_en_00.pdf.

General Information

**Warning**

Disregarding this warning may result in damage to equipment and/or serious personal injury. Only qualified personnel may start up and operate these devices. According to the safety instructions in this text, qualified personnel are persons who are authorized to start up, to ground, and to mark devices, systems, and equipment according to the standards of safety technology. In addition, these persons must be familiar with all warning instructions and maintenance measures in this text.

**Warning**

The FL IL 24 BK-PN-PAC module is designed exclusively for SELV operation according to IEC 60950/EN 60950/VDE 0805.

**Shielding**

The shielding ground of the connected twisted pair cables is electrically connected to the female connector. When connecting network segments, avoid ground loops, potential transfers, and voltage equalization currents using the braided shield.

**Electrostatic discharge**

The module contains components that can be damaged or destroyed by electrostatic discharge. When handling the module, observe the necessary safety precautions against electrostatic discharge (ESD) according to EN 61340-5-1 and EN 61340-5-2 .

**Housing**

Only authorized Phoenix Contact personnel are permitted to open the housing.

Structure of the FL IL 24 BK-PN-PAC Bus Coupler

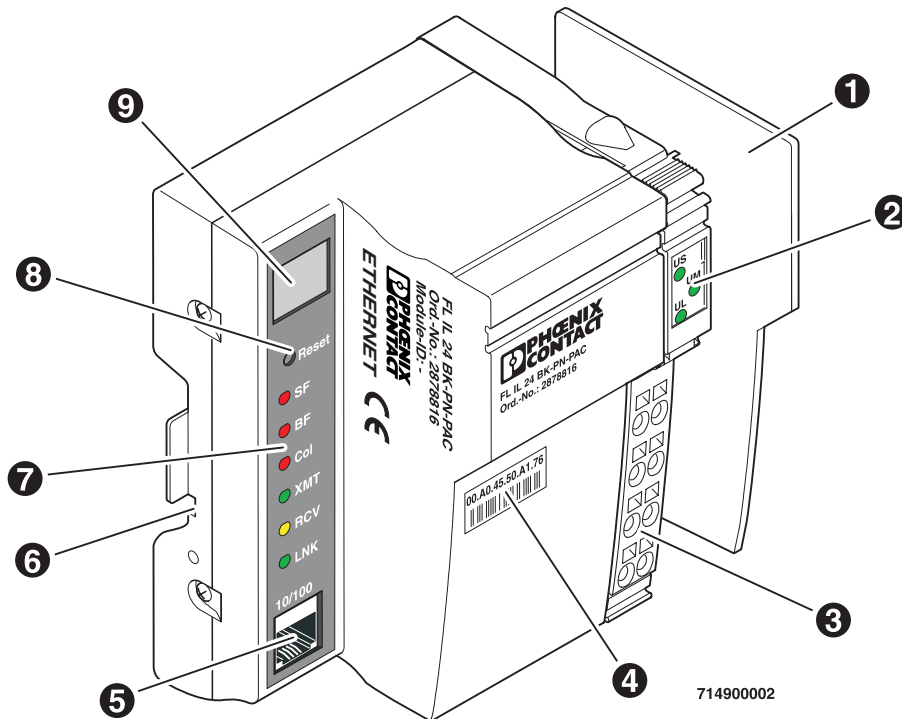

Figure 1 Structure of the FL IL 24 BK-PN-PAC bus coupler

The bus coupler has the following components:

- 1 End plate to protect the last Inline module
- 2 Inline diagnostic indicators
- 3 24 V DC supply and functional earth ground connector
- 4 MAC address in plain text and as a barcode
- 5 Ethernet interface (twisted pair cables in RJ45 format)
- 6 Two PE contacts for grounding the bus coupler using a DIN rail (on the back of the module)
- 7 PROFINET/Ethernet status and diagnostic indicators
- 8 Reset button
- 9 7-segment display for the device status

Local Status and Diagnostic Indicators

Des.	Color	Status	Meaning
Electronics Module			
UL	Green	ON	24 V supply, 7 V communications power/interface supply in the tolerance range
		OFF	24 V supply, 7 V communications power/interface supply not in the tolerance range
UM	Green	ON	Voltage is present in the main circuit (+24 V DC)
		OFF	Voltage is not present in the main circuit
US	Green	ON	24 V segment supply is present
		OFF	24 V segment supply is not present
Ethernet Port			
SF	Red	ON	System error present (incorrect parameterization, bus error, peripheral fault)
		OFF	No system error, INTERBUS running without errors
BF	Red	ON	No link status available
		Flashing	Link status available, no communication connection to the IO controller, connection establishment is currently active
		OFF	The IO controller has established an active communication connection to the IO device
COL	Red	ON	Collision of data telegrams
		OFF	Transmission of telegrams without a collision (if LNK LED active)
XMT	Green	ON	Data telegrams are being sent
		OFF	Data telegrams are not being sent
RCV	Yellow	ON	Data telegrams are being received
		OFF	Data telegrams are not being received
LNK	Green	ON	Physical network connection ready to operate
		OFF	Physical network connection interrupted or not present

Reset Button

The reset button is on the front plate. When the reset button is pressed the Inline masterboard and the Ethernet adapter are completely reset and initialized (selftest, etc.). Inline system outputs are reset and inputs are not read.

Following reset, the module is automatically started up again by the PROFINET IO controller.

Installation and Mounting/Removal

Install the FL IL 24 BK-PN-PAC on a clean DIN rail according to EN 60715 (Phoenix Contact: item NS 35...). To avoid contact resistance only use clean, corrosion-free DIN rails. End clamps must be mounted on both sides of the module to stop the terminals from slipping on the DIN rail.



The functional earth ground must be connected to the 24 V DC supply/functional earth ground connection. The contacts are directly connected to the potential jumper and FE springs on the bottom of the housing. The coupler is grounded when it is snapped onto a grounded DIN rail. Functional earth ground is only used to discharge interference.

Mounting

1. First, snap all required electronics bases vertically onto the DIN rail (A).



Ensure that **all** featherkeys and keyways on adjacent terminals are interlocked (B).

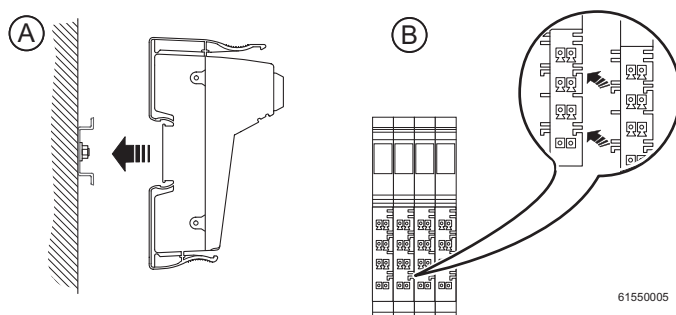

Figure 2 Snapping on the electronics base

2. Next, attach the connectors to the corresponding bases.

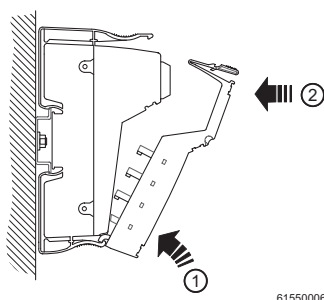

Figure 3 Plugging in the I/O connector

Connecting the Supply Voltage

The module is operated using a +24 V DC SELV.

Typical Connection of the Supply Voltage

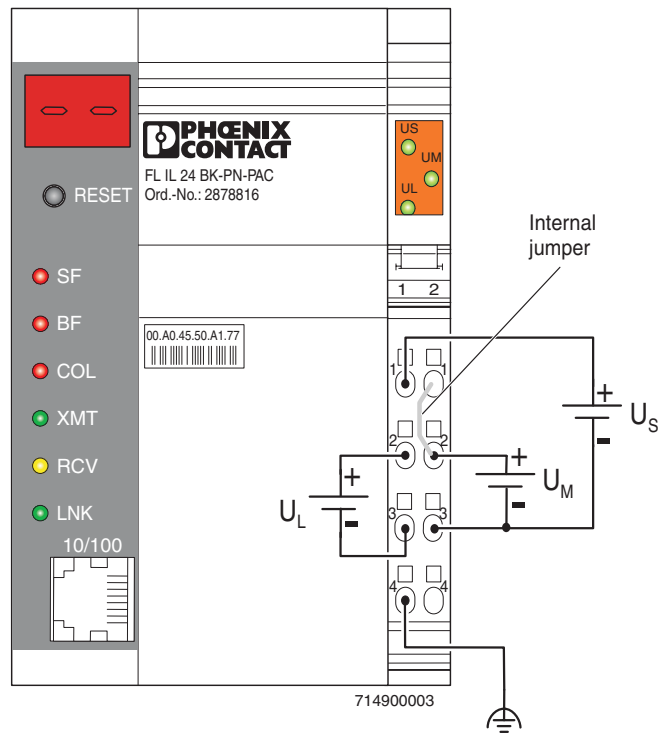

Figure 4 Typical connection of the supply voltage

Connector Assignment

Terminal Point	Assignment		Remark
Connector	Power Connector		
1.1	24 V DC (U _S)	24 V segment supply	The supplied voltage is directly led to the potential jumper.
1.2	24 V DC (U _L)	24 V power supply	The communications power for the bus coupler and the connected local bus devices is generated from this voltage. The 24 V analog voltage (U _{ANA}) for the local bus devices is also generated.
2.1, 2.2	24 V DC (U _M)	Main voltage	The main voltage is routed to the local bus devices via the potential jumpers.
1.3	LGND	Reference potential logic ground	The potential is the reference ground for the communications power.
2.3	SGND	Reference potential segment ground	The reference potential is directly led to the potential jumper and is, at the same time, ground reference for the main and segment supply.
1.4, 2.4	FE	Functional earth ground (FE)	The functional earth ground must be connected to the 24 V DC supply/functional earth ground connection. The contacts are directly connected to the potential jumper and FE springs on the bottom of the housing. The coupler is grounded when it is snapped onto a grounded DIN rail. Functional earth ground is only used to discharge interference.



The maximum total current flowing through the potential jumpers is 8 A.



The functional earth ground must be connected through the 24 V DC supply/functional earth ground connection.

24 V Segment Supply/24 V Main Supply

The segment supply and main supply must have the same reference potential. An electrically isolated architecture is not possible.

24 V Segment Supply

An emergency stop circuit, for example, can be connected and switched on the connector between terminal points 1.1/2.1. This means that there is no segment supply via terminal point 1.1.

In addition, it is possible to supply the segment supply from the main voltage. For this, 1.1/2.1 must be jumpered.



The 24 V segment supply is protected against polarity reversal (inverse-parallel diode -> causes a short circuit in the event of polarity reversal) and surge voltage.

It does not have short-circuit protection.

The user must provide short-circuit protection. The rating of the preconnected fuse must be such that the maximum permissible load current is not exceeded.

24 V Main Supply



The 24 V main supply is protected against polarity reversal (inverse-parallel diode -> causes a short circuit in the event of polarity reversal) and surge voltage.

It does not have short-circuit protection.

The user must provide short-circuit protection. The rating of the preconnected fuse must be such that the maximum permissible load current is not exceeded.

24 V BK Supply



The 24 V BK supply is protected against polarity reversal and surge voltage. These protective elements are only used to protect the power supply unit.

Jumpers



Terminals 1.3 and 2.3 on the connector can be jumpered if the same reference potential is to be used for the communications power and segment voltage.

Ethernet Connection

Ethernet Interface

The FL IL 24 BK-PN-PAC has an Ethernet interface on the front in RJ5 format, to which only a twisted pair cable with an impedance of $100\ \Omega$ can be connected. The data transmission rate is 100 Mbps. The 100BASE-TX port of the bus coupler can detect a pair of incorrectly connected receiving cables (RD+/RD-) and correct them using the auto polarity correction function.

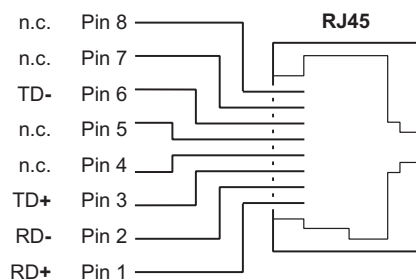

Figure 5 Pin assignment of the Ethernet port in RJ45 format

Transfer of I/O Data

The I/O data of individual Inline modules is transferred via memory areas organized in a word-oriented way (separate memory areas for input and output data). The Inline modules use the memory according to their process data width. The assignment of the individual bits is shown in the following diagram:



Figure 6 Position of the user data for individual devices in the word array

To achieve cycle consistency between I/O data and the station bus cycle, the bus coupler uses an exchange buffer mechanism. This mechanism ensures that the required I/O data is available on time and is protected by appropriate measures when writing/reading.

The following diagram shows the position of the user data for several devices in the word array.

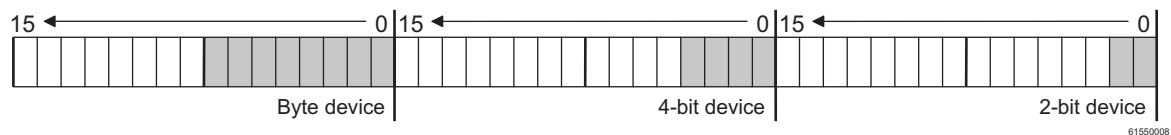

Figure 7 Position of the user data for several devices in the word array

Meaning of the 7-Segment Display

During Startup/Operation

Display	Meaning
01	Boot Loader is started
bo	Firmware is extracted
02	Firmware is started
--	Initializing the PROFINET IO stack
--	Operation
SL alternating with xx	Malfunction in the INTERBUS network
00 alternating with --	PROFINET device ID

During Firmware Update



An application note for firmware update via TFTP (AH EN TFTP FIRMWARE UPDATE) can be found in the Download Center at www.download.phoenixcontact.com.

Display	Meaning
03	Firmware is requested to download at TFTP server
04	The firmware is downloaded to the memory
05	The firmware transfer to the memory is complete



In the event of a System Fail (SF), the slot number is indicated on the 7-segment display. Example: Error at slot 3. Display: "SL" alternating with "03" in the second clock.

Boot Loader Error Messages

Display	Meaning	Remedy
17	The transfer of the firmware failed during TFTP download (display changes from "03" to "17")	<ul style="list-style-type: none"> – Check the physical connection – Establish a point-to-point connection – Make sure that the file (with the specified file name) exists and is in the correct directory – Check the IP address of the TFTP server – Activate the TFTP server – Repeat the download
19	The TFTP download was completed successfully, but the file is not a valid firmware version for the bus coupler	<ul style="list-style-type: none"> – Provide a valid firmware version with the previously specified file name – Repeat the download



The points under "Remedy" are recommendations; they do not all have to be carried out for every error.

Startup



Make sure you always use the latest version of the GSDML file and the latest documentation for the module. The latest GSDML files and documentation can be found on the Internet at www.download.phoenixcontact.com in the Download Center.



Quick Start Guides for PC WorX 5 and Siemens S7 can be found in the Download Center at www.download.phoenixcontact.com.
 PC WorX: "Quick Start Guide PC WorX 5" (UM QS EN PC WORX 5, Order No. 26 99 86 2)
 Siemens S7: "Quick Start Guide STEP 7" (UM QS EN PROFINET PROXY IB, Order No. 26 99 99 8)

Starting the Firmware

The firmware is started once the device has been connected to the power supply or the reset button has been pressed. The following sequence is displayed:

Display	Meaning
01	Boot Loader is started
bo	Firmware is extracted
02	Firmware is started
--	Initializing the PROFINET IO stack
--	Operation

Update Rate

The minimum update rate is 4 ms. Always set an update rate higher than the bus cycle time. The bus cycle time can be read using DIAG+ or PC WorX.

Diagnostic Indicators During Operation and in the Event of an Error

LED	Meaning	Measure/Remedy in the Event of an Error
States During Operation:		
SF BF RDY/RUN FAIL	OFF Flashing Flashing OFF	PROFINET IO device waiting for communication with the PROFINET IO controller. INTERBUS is not parameterized.
SF BF RDY/RUN FAIL	OFF OFF ON OFF	PROFINET IO controller established communication without any errors.
States in the Event of an Error:		
SF BF RDY/RUN FAIL Display	ON OFF Flashing ON SL alternating with 01	PROFINET IO controller was parameterized incorrectly. The INTERBUS configuration that was sent from the PROFINET IO controller to the PROFINET IO device could not be executed.
SF BF RDY/RUN FAIL Display FAIL	ON OFF Flashing ON 02 ... xx OFF	INTERBUS errors during operation Diagnostic display indicates the slot (SL alternating with the slot number).
SF BF RDY/RUN FAIL COL XMT RCV Link	OFF ON ON OFF OFF OFF OFF OFF	The physical communication connection was interrupted, the PROFINET IO controller can no longer be reached. No link.
		Check parameterization and correct. There is a bus error or peripheral fault. Restore the physical connection.

Management Information Base - MIB



The latest MIBs can be found on the Internet at www.download.phoenixcontact.com.

Mapping Inputs and Outputs to PROFINET IO

The module is assigned the following input and output data words:

Slot	Data Length
Slot 0	-
Slot 1	4 words IN/4 words OUT

Status and Diagnostic Register

Diagnostic Register

The controller board diagnostic registers (diagnostic status register, diagnostic parameter register, and extended diagnostic parameter register) represent the current state of the

INTERBUS system for the user. Thus, it is possible to indicate the state of the bus system, error causes, as well as additional information to the application program.

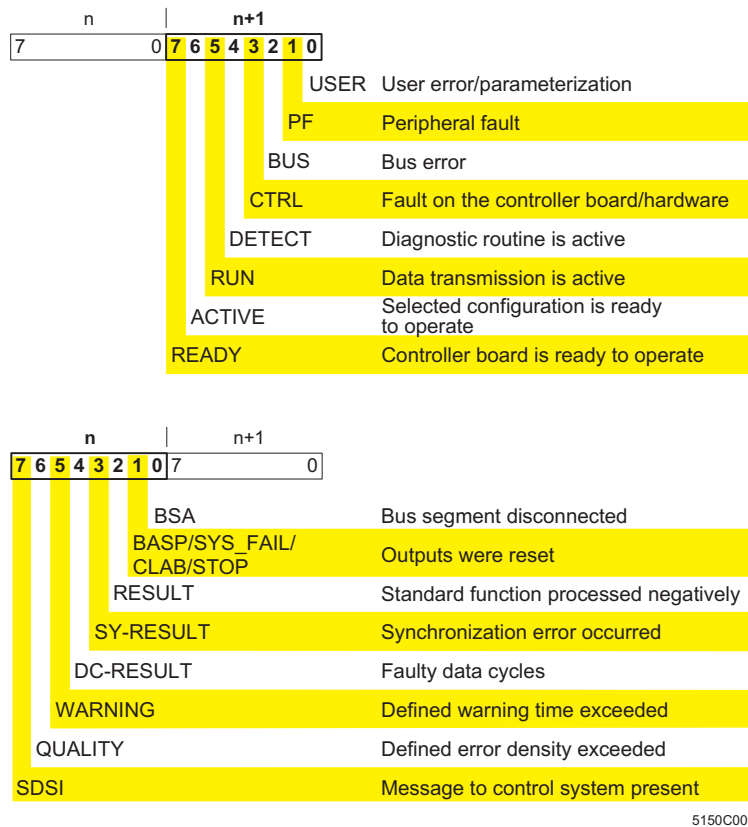

Figure 8 Diagnostic Status Register



Quick Start Guides for PC WorX 5 and Siemens S7 can be found in the Download Center at www.download.phoenixcontact.com.
 PC WorX: "Quick Start Guide PC WorX 5" (UM QS EN PC WORX 5, Order No. 26 99 86 2)
 Siemens S7: "Quick Start Guide STEP 7" (UM QS EN PROFINET PROXY IB, Order No. 26 99 99 8)

Parameterization

PC WorX

PC WorX Version 5.0 or later is required to parameterize the PROFINET IO devices. An online data sheet with important technical data and a configuration file is integrated into PC WorX. If several versions of the configuration file are available, make sure that the file version used corresponds to the firmware/hardware version used.

Other Tools

The PROFINET IO device is parameterized using the configuration tool of the PROFINET IO controller. To do this, integrate the appropriate GSDML file of the device into the corresponding software tool (STEP 7/hardware configuration, etc.). Make sure that the file version used corresponds to the firmware/hardware version used.



The latest version of the GSDML file can be downloaded at www.download.phoenixcontact.com.

Parameters:

Slot 0: Diagnostic alarm (active (default)/inactive)

PROFINET IO enables the PROFINET IO device to store diagnostic information with the error location and error type.

The PROFINET IO controller is informed that a diagnosis has been received via an incoming alarm. Alarms are only sent if they were enabled via parameters during startup.

If the diagnosis has been removed, an outgoing alarm is sent to the controller.

If at least one diagnosis is stored, the SL LED lights up. If no diagnoses are present, the SL LED is not active.

Bus errors are indicated with higher priority in the display than peripheral faults.

Technical Data

General Data

Function	PROFINET IO/Inline bus coupler
Housing dimensions (width x height x depth)	90 mm x 72 mm x 116 mm
Permissible operating temperature (EN 60204-1)	0°C to +55°C
Permissible storage temperature (EN 60204-1)	-25°C to +85°C
Degree of protection	IP20, DIN 40050, IEC 60529
Class of protection	Class 3 VDE 0106; IEC 60536
Humidity (operation) (EN 60204-1)	5% to 90%, no condensation
Humidity (storage) (EN 60204-1)	5% to 95%, no condensation
Air pressure (operation)	80 kPa to 108 kPa, 2000 m above sea level
Air pressure (storage)	70 kPa to 108 kPa, 3000 m above sea level
Preferred mounting position	Perpendicular to a standard DIN rail
Connection to protective earth ground	The functional earth ground must be connected to the 24 V DC supply/functional earth ground connection. The contacts are directly connected to the potential jumper and FE springs on the bottom of the housing. The coupler is grounded when it is snapped onto a grounded DIN rail. Functional earth ground is only used to discharge interference.
Environmental compatibility	Free from substances which would hinder coating with paint or varnish (according to VW specification)
Resistance to solvents	Standard solvents
Weight	270 g, typical

PROFINET Functions

Device function	PROFINET IO device
PROFINET IO specification	Version 1.1
Minimum update rate	4 ms, depending on the size of the bus system

Supported Protocols/MIBs

Supported protocols	PROFINET IO TCP/UDP SNMPv2 TFTP HTTP ICMP (ping)
Supported standard MIBs	RFC 1213 (MIB II)
Supported private MIBs	Phoenix-Contact-MIB FL-MIB FL-Device-MIB

24 V Main Supply/24 V Segment Supply

Connection method	Spring-cage terminals
Recommended cable lengths	30 m, maximum; do not route cable through outdoor areas
Routing	Through potential routing

24 V Main Supply/24 V Segment Supply (Continued)

Special demands on the voltage supply	The U_S/U_M supplies and the U_{BK} bus coupler supply are provided using two electrically isolated power supply units and therefore do not have the same reference potential.
Behavior in the event of voltage fluctuations	Voltages (main and segment supply) that are transferred from the bus coupler to the potential jumpers follow the supply voltages without delay.
Nominal value	24 V DC
Tolerance	-15%/+20% (according to EN 61131-2)
Ripple	±5%
Permissible range	19.2 V to 30 V
Current carrying capacity	8 A, maximum
Safety equipment	
Surge voltage	Input protective diodes (can be destroyed by permanent overload) Pulse loads up to 1500 V are short circuited by the input protective diode.
Polarity reversal	Parallel diodes for protection against polarity reversal; in the event of an error the high current through the diodes causes the preconnected fuse to blow.



This 24 V area must be protected externally. The power supply unit must be able to supply 4 times (400%) the nominal current of the external fuse, to ensure that the fuse blows safely in the event of an error.

24 V Bus Coupler Supply

Connection method	Spring-cage terminals
Recommended cable lengths	30 m, maximum; do not route cable through outdoor areas
Routing	Through potential routing
Safety equipment	
Surge voltage	Input protective diodes (can be destroyed by permanent overload) Pulse loads up to 1500 V are short circuited by the input protective diode.
Polarity reversal	Serial diode in the lead path of the power supply unit; in the event of an error only a low current flows. In the event of an error the fuse in the external power supply unit does not trip. Ensure protection of 2 A by fuses through the external power supply unit.



Observe the current consumption of the modules

Observe the logic current consumption of each device when configuring an Inline station. This information is given in every module-specific data sheet. The current consumption can differ depending on the individual module. The permissible number of devices that can be connected therefore depends on the specific station structure.

Nominal value	24 V DC
Tolerance	-15%/+20% (according to EN 61131-2)
Ripple	±5%

24 V Bus Coupler Supply (Continued)

Permissible range	19.2 V to 30 V
Minimum current consumption at nominal voltage	92 mA (At no-load operation, i.e., Ethernet connected, no local bus devices are connected, bus inactive)
Maximum current consumption at nominal voltage	1.5 A (Loading the 7.5 V communications power with 2 A, the 24 V analog voltage with 0.5 A)

24 V Module Supply

- Communications Power (Potential Jumper)

Nominal value	7.5 V DC
Tolerance	±5%
Ripple	±1.5%
Maximum output current	2 A DC (observe derating)
Safety equipment	Electronic short-circuit protection

- Analog Supply (Potential Jumper)

Nominal value	24 V DC
Tolerance	-15%/+20%
Ripple	±5%
Maximum output current	0.5 A DC (observe derating)
Safety equipment	Electronic short-circuit protection

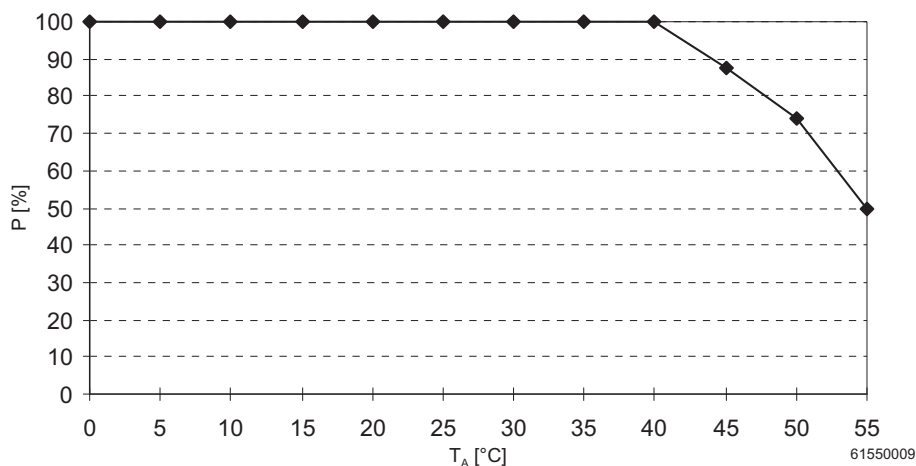
Derating of the Communications Power and the Analog Terminal Supply

P [%]	Loading capacity of the power supply unit for communications power and analog supply in %
T_A [°C]	Ambient temperature in °C

Power Dissipation**Formula to Calculate the Power Dissipation of the Electronics**

$$P_{EL} = P_{BUS} + P_{PERI}$$

$$P_{EL} = 2.6 \text{ W} + \left(1.1 \frac{\text{W}}{\text{A}} \times \sum_{n=0}^a I_{Ln}\right) + \left(0.7 \frac{\text{W}}{\text{A}} \times \sum_{m=0}^b I_{Lm}\right)$$

Where

P_{EL}	Total power dissipation in the terminal
P_{BUS}	Power dissipation for bus operation without I/O load (permanent)
P_{PERI}	Power dissipation with I/O connected

I_{Ln}	Current consumption of device n from the communications power
n	Index of the number of connected devices ($n = 1$ to a)
a	Number of connected devices (supplied with communications power)

$\sum_{n=0}^a I_{Ln}$	Total current consumption of the devices from the 7.5 V communications power (2 A, maximum)
-----------------------	------------------------------------------------------------------------------------------------

I_{Lm}	Current consumption of the device m from the analog supply
m	Index of the number of connected analog devices ($m = 1$ to b)
b	Number of connected analog devices (supplied with analog voltage)

$\sum_{m=0}^b I_{Lm}$	Total current consumption of the devices from the 24 V analog supply (0.5 A, maximum)
-----------------------	------------------------------------------------------------------------------------------

Power Dissipation/Derating

Using the maximum currents 2 A (logic current) and 0.5 A (current for analog terminals) in the formula to calculate the power dissipation when the I/O is connected gives the following result:

$$P_{PERI} = 2.2 \text{ W} + 0.35 \text{ W} = 2.55 \text{ W}$$

2.55 W corresponds to 100% current carrying capacity of the power supply unit in the derating curves on page 18.

Make sure that the indicated nominal current carrying capacity in the derating curves is not exceeded when the ambient temperature is above 40°C. Corresponding with the formula, the total current carrying capacity of the connected I/O is relevant (P_{PERI}). If, for example, no current is drawn from the analog supply, the percentage of current coming from the communications power can be increased.

Example:

Ambient temperature: 55°C

Nominal current carrying capacity of the communications power and analog supply: 50% according to the diagram

$$\begin{aligned} I_{LLogic} &= 1 \text{ A}, I_{LAnalog} = 0.25 \text{ A} \\ P_{PERI} &= 1.1 \text{ W} + 0.175 \text{ W} \\ P_{PERI} &= 1.275 \text{ W (equals 50% of 2.55 W)} \end{aligned}$$

Possible logic current if the analog supply is not loaded:

$$\begin{aligned} P_{PERI} &= 1.1 \text{ W/A} \times I_{LLogic} + 0 \text{ W} \\ P_{PERI}/1.1 \text{ W/A} &= I_{LLogic} \\ I_{LLogic} &= 1.275 \text{ W}/1.1 \text{ W/A} \\ I_{LLogic} &= 1.159 \text{ A} \end{aligned}$$

Safety Equipment

Surge voltage (segment supply/main supply/bus terminal supply)	Input protective diodes (can be destroyed by permanent overload) Pulse loads up to 1500 V are short circuited by the input protective diode.
Polarity reversal (segment supply/main supply)	Parallel diodes for protection against polarity reversal; in the event of an error the high current through the diodes causes the preconnected fuse to blow.
Polarity reversal (bus terminal supply)	Serial diode in the lead path of the power supply unit; in the event of an error only a low current flows. In the event of an error the fuse in the external power supply unit does not trip. Ensure protection of 2 A by fuses through the external power supply unit.

Bus Interface of the Lower-Level System Bus

Interface	Inline local bus
Electrical isolation	No
Number of Inline terminals that can be connected	
Limitation through software	63, maximum
Limitation through power supply unit	Maximum logic current consumption of the connected local bus modules: $I_{\max} \leq 2 \text{ A DC}$



Observe the current consumption of the modules
Observe the logic current consumption of each device when configuring an Inline station. This information is given in every module-specific data sheet. The current consumption can differ depending on the individual module. The permissible number of devices that can be connected therefore depends on the specific station structure.

Interfaces

Ethernet Interface	
Number	One
Connection format	8-pos. RJ45 female connector on the bus coupler
Connection medium	Twisted pair cable with a conductor cross section of 0.14 mm^2 to 0.22 mm^2
Cable impedance	100 Ω
Transmission speed	100 Mbps
Maximum network segment expansion	100 m

Mechanical Tests

Shock test according to IEC 60068-2-27	Operation/storage/transport: 25g, 11 ms period, half-sine shock pulse
Vibration resistance according to IEC 60068-2-6	Operation/storage/transport: 5g, 150 Hz, Criterion A
Free fall according to IEC 60068-2-32	1 m

Conformance With EMC Directives

Developed according to IEC 61000-6-2

IEC 61000-4-2 (ESD) Criterion B

IEC 61000-4-3 (radiated-noise immunity) Criterion A

IEC 61000-4-4 (burst) Criterion B

IEC 61000-4-5 (surge) Criterion B

IEC 61000-4-6 (conducted noise immunity) Criterion A

EN 55011 (noise emission) Class A



Warning: Portable radiotelephone equipment ($P \geq 2 \text{ W}$) must not be operated any closer than 2 m. There should be no strong radio transmitters or ISM (Industrial Scientific and Medical) devices in the vicinity.

Ordering Data

Description	Type	Order No.	Pcs./Pkt.
PROFINET IO/Inline bus coupler	FL IL 24 BK-PN-PAC	28 78 81 6	1



Please note that the required GSDML file is not supplied with the device. Make sure you always use the latest version of the GSDML file. The latest GSDML files and documentation can be found on the Internet at www.download.phoenixcontact.com in the Download Center.

Accessories

Description	Type	Order No.	Pcs./Pkt.
PC WorX 5 for PROFINET IO	PC WORX 5 PN	29 85 02 6	1
Startup/diagnostic software - Factory Manager	FL SWT	28 31 04 4	1
Connector, with color print	IB IL SCN-8-CP	27 27 60 8	1
Labeling field	IB IL FIELD 8	27 27 50 1	1
End clamp	E/UK	12 01 44 2	1
Zack "Quick" marker strip	ZBFM 6-... (see CLIPLINE)		-
Factory Manager, network management software	FL SWT	28 31 04 4	1
OPC server	IBS OPC SERVER	27 29 12 7	1
Gray RJ45 connector set for linear cable	FL PLUG RJ45 GR/2	27 44 85 6	2
Green RJ45 connector set for crossed cable	FL PLUG RJ45 GN/2	27 44 57 1	2
Double sheathed Ethernet cable	FL CAT5 HEAVY	27 44 81 4	-
Flexible Ethernet cable	FL CAT5 FLEX	27 44 83 0	-
Assembly tool for RJ45 connector	FL CRIMPTOOL	27 44 86 9	1

Documentation

Description	Type	Order No.
"Configuring and Installing the INTERBUS Inline Product Range" user manual	IB IL SYS PRO UM E	27 43 04 8
"PC WorX 5" Quick Start Guide	UM QS EN PC WORX 5	26 99 86 2
"STEP 7" Quick Start Guide	UM QS EN PROFINET PROXY IB	26 99 99 8
Application note for firmware update of the device	AH EN TFTP FIRMWARE UPDATE	

© PHOENIX CONTACT 07/2005



SCATTERGOOD & JOHNSON LTD

ELECTRICAL ENGINEERING & FLUID CONTROL DISTRIBUTORS

Est.1899

At Scattergood & Johnson Ltd, we pride ourselves on being a technical distributor to specialist industries.

Working with a range of quality product suppliers across a number of specialist markets, we are not your average 'box shifter' - we are your technical and supply chain partner.

We fully support every product we sell - for free! Our internal team and external sales engineers can answer any product or application question, no matter the complexity.

Backing up this technical ability is a range of 50,000+ products available from stock for nationwide next day delivery (same day if required!), or you can collect what you need from any of our trade counters around the UK.

Select your specialist interest below to learn more about how we can help.

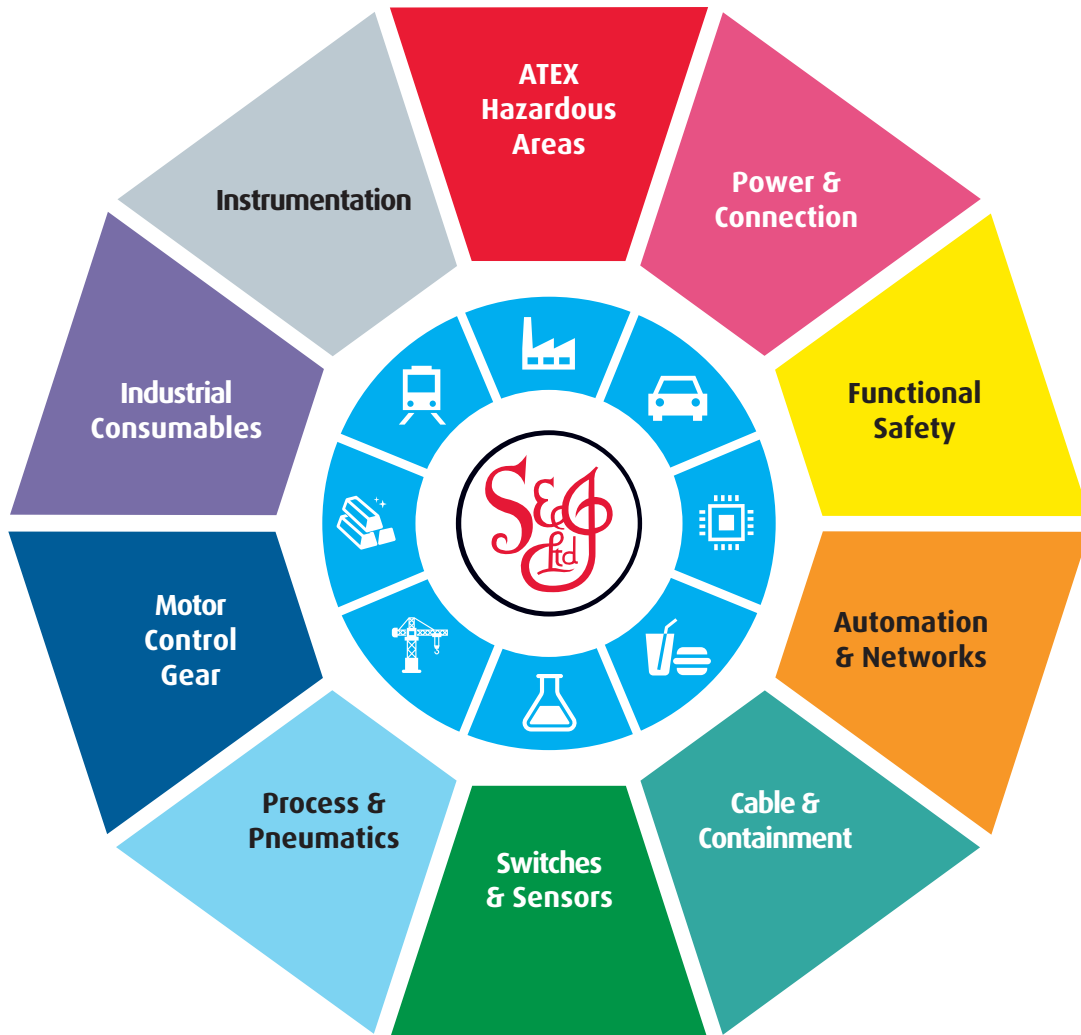

Online, In Branch and On the Road - Scattergood & Johnson Ltd, there when you need us.

www.scatts.co.uk