

AUTOMATION



User manual

UM EN PROFINET CTRL DEV

PROFINET IO controller/device functions

AUTOMATION

User manual

PROFINET IO controller/device functions

2010-04-19

Designation: UM EN PROFINET CTRL DEV

Revision: 00

This user manual is valid for:

PROFINET IO devices from Phoenix Contact

Please observe the following notes

In order to ensure the safe use of the product described, you have to read and understand this manual. The following notes provide information on how to use this manual.

User group of this manual

The use of products described in this manual is oriented exclusively to qualified electricians or persons instructed by them, who are familiar with applicable national standards and other regulations regarding electrical engineering and, in particular, the relevant safety concepts.

Phoenix Contact accepts no liability for erroneous handling or damage to products from Phoenix Contact or third-party products resulting from disregard of information contained in this manual.

Explanation of symbols used and signal words



This is the safety alert symbol. It is used to alert you to potential personal injury hazards. Obey all safety measures that follow this symbol to avoid possible injury or death.



DANGER

This indicates a hazardous situation which, if not avoided, will result in death or serious injury.



WARNING

This indicates a hazardous situation which, if not avoided, will result in death or serious injury.



CAUTION

This indicates a hazardous situation which, if not avoided, could result in minor or moderate injury.

The following types of messages provide information about possible property damage and general information concerning proper operation and ease-of-use.



NOTE

This symbol and the accompanying text alerts the reader to a situation which may cause damage or malfunction to the device, either hardware or software, or surrounding property.



This symbol and the accompanying text provides additional information to the reader. It is also used as a reference to other sources of information (manuals, data sheets, literature) on the subject matter, product, etc.

Please observe the following notes

General terms and conditions of use for technical documentation

Phoenix Contact reserves the right to alter, correct, and/or improve the technical documentation and the products described in the technical documentation at its own discretion and without giving prior notice, insofar as this is reasonable for the user. The same applies to any technical changes that serve the purpose of technical progress.

The receipt of technical documentation (in particular data sheets, installation instructions, manuals, etc.) does not constitute any further duty on the part of Phoenix Contact to furnish information on alterations to products and/or technical documentation. Any other agreement shall only apply if expressly confirmed in writing by Phoenix Contact. Please note that the supplied documentation is product-specific documentation only and that you are responsible for checking the suitability and intended use of the products in your specific application, in particular with regard to observing the applicable standards and regulations. Although Phoenix Contact makes every effort to ensure that the information content is accurate, up-to-date, and state-of-the-art, technical inaccuracies and/or printing errors in the information cannot be ruled out. Phoenix Contact does not offer any guarantees as to the reliability, accuracy or completeness of the information. All information made available in the technical data is supplied without any accompanying guarantee, whether expressly mentioned, implied or tacitly assumed. This information does not include any guarantees regarding quality, does not describe any fair marketable quality, and does not make any claims as to quality guarantees or guarantees regarding the suitability for a special purpose.

Phoenix Contact accepts no liability or responsibility for errors or omissions in the content of the technical documentation (in particular data sheets, installation instructions, manuals, etc.).

The aforementioned limitations of liability and exemptions from liability do not apply, in so far as liability must be assumed, e.g., according to product liability law, in cases of premeditation, gross negligence, on account of loss of life, physical injury or damage to health or on account of the violation of important contractual obligations. Claims for damages for the violation of important contractual obligations are, however, limited to contract-typical, predictable damages, provided there is no premeditation or gross negligence, or that liability is assumed on account of loss of life, physical injury or damage to health. This ruling does not imply a change in the burden of proof to the detriment of the user.

UM EN PROFINET CTRL DEV

Statement of legal authority

This manual, including all illustrations contained herein, is copyright protected. Use of this manual by any third party is forbidden. Reproduction, translation, and public disclosure, as well as electronic and photographic archiving or alteration requires the express written consent of Phoenix Contact. Violators are liable for damages.

Phoenix Contact reserves all rights in the case of patent award or listing of a registered design. Third-party products are always named without reference to patent rights. The existence of such rights shall not be excluded.

How to contact us**Internet**

Up-to-date information on Phoenix Contact products and our Terms and Conditions can be found on the Internet at:

www.phoenixcontact.com



Make sure you always use the latest documentation.

It can be downloaded at:

www.phoenixcontact.net/catalog

Subsidiaries

If there are any problems that cannot be solved using the documentation, please contact your Phoenix Contact subsidiary.

Subsidiary contact information is available at www.phoenixcontact.com.

Published by

PHOENIX CONTACT GmbH & Co. KG
 Flachsmarktstraße 8
 32825 Blomberg
 Germany
 Phone +49 - (0) 52 35 - 3-00
 Fax +49 - (0) 52 35 - 3-4 12 00

PHOENIX CONTACT
 P.O. Box 4100
 Harrisburg, PA 17111-0100
 USA
 Phone +1-717-944-1300

Should you have any suggestions or recommendations for improvement of the contents and layout of our manuals, please send your comments to

tecdoc@phoenixcontact.com

Table of contents

| | | |
|-------|--|------|
| 1 | PROFINET IO controller/device functions | 1-1 |
| 1.1 | User group of the manual | 1-1 |
| 1.2 | Basic knowledge required | 1-1 |
| 1.3 | Additional PROFINET documentation | 1-1 |
| 1.4 | System requirements..... | 1-2 |
| 1.5 | PROFINET IO controller/device functions | 1-3 |
| 2 | Network topologies | 2-1 |
| 2.1 | Topology 1: Mechatronic unit with lower-level compact controllers | 2-1 |
| 2.2 | Topology 2: Four identical machine controllers under a machine park controller | 2-2 |
| 2.3 | Topology 3: System control with lower-level subsystems | 2-3 |
| 3 | Description of a typical application (all devices in one network) | 3-1 |
| 3.1 | Information on how it was carried out | 3-1 |
| 3.2 | Typical application..... | 3-4 |
| 3.3 | Offline configuration..... | 3-7 |
| 3.3.1 | Lower-level project | 3-7 |
| 3.3.2 | Higher-level project | 3-12 |
| 3.4 | Online configuration..... | 3-19 |
| 3.4.1 | Preparing the PC for communication | 3-19 |
| 3.4.2 | Configuring the ILC 170 ETH 2TX | 3-20 |
| 3.4.3 | Configuring the ILC 330 PN | 3-25 |
| 3.4.4 | Observe startup behavior | 3-26 |
| 3.4.5 | Checking the program start of the higher-level project | 3-27 |
| 3.4.6 | Checking the program start of the lower-level project | 3-28 |
| 4 | Description of a typical application (devices in several networks) | 4-1 |
| 4.1 | Offline configuration..... | 4-3 |
| 4.1.1 | Lower-level project | 4-3 |
| 4.1.2 | RFC 470 PN-3TX higher-level/lower-level project | 4-8 |
| 4.1.3 | Higher-level project | 4-14 |
| 4.2 | Online configuration..... | 4-22 |
| 4.2.1 | Preparing the PC for communication | 4-22 |
| 4.2.2 | Configuring the ILC 170 ETH 2TX | 4-23 |
| 4.2.3 | Configuring the RFC 470 PN-3TX | 4-25 |
| 4.2.4 | Configuring the ILC 330 PN | 4-26 |
| 4.2.5 | Observe startup behavior | 4-30 |

UM EN PROFINET CTRL DEV

| | | |
|-------|--|------|
| 4.2.6 | Checking the program start of the higher-level project | 4-32 |
| 4.2.7 | Checking the program start of the lower-level project | 4-33 |

1 PROFINET IO controller/device functions

The "PROFINET IO controller/device functions (UM EN PROFINET CTRL DEV) user manual provides an overview of the PROFINET communication system with device functions. This system description provides support when installing, starting up or operating a PROFINET device system. Examples show you how to program IO device diagnostics.

1.1 User group of the manual

Use this user manual if you are responsible for programming user programs or configuring, starting up and servicing automation systems.

1.2 Basic knowledge required

The following knowledge is required to understand the user manual:

- General knowledge with regard to automation technology
- Knowledge on how to use computers or equipment similar to a PC (e.g., programming devices) under the Windows operating system
- Knowledge of how to use PC WorX
- Good knowledge of the PROFINET IO communication method.

1.3 Additional PROFINET documentation

The PROFINET documentation is modular, providing you with optimum information.

Available PROFINET documents

"PROFINET basics" user manual UM EN PROFINET SYS

The manual describes PROFINET system basics.
This includes:

- PROFINET development
- PROFINET versions
- PROFINET properties
- PROFINET installation and startup
- PROFINET and wireless

UM EN PROFINET CTRL DEV

Quick start guides

- "Installing and starting up the starterkit 3.0" quick start guide
UM QS EN PROFINET STARTERKIT 3.0.
- "Configuring INTERBUS devices in a PROFINET IO network using the example of STEP 7"
UM QS EN PROFINET PROXY IB

Device-specific data sheets

The data sheets describe the specific properties of PROFINET IO devices. These include:

- Function description
- Ordering data and technical data
- Local diagnostic and status indicators
- Pin assignment and connection example
- Programming data/configuration data

PROFINET documents in preparation

- "Acyclic communication" application note
AH EN PROFINET AZY KOM
- "PROFINET diagnostics" application note
AH EN PROFINET DIAG



Make sure you always use the latest documentation. It can be downloaded at:

www.phoenixcontact.net/catalog

1.4 System requirements



Please note that the PROFINET IO device function of the ILC170 ETH 2TX is only available in the PC WorX software from version 6.00 Service Pack 2 or later (part of the AUTOMATIONWORX Software Suite 2009 1.50 Service Pack 2). The PC WorX Express software does not support these functions.



Firmware 3.5x for all controllers, including the PROFINET IO device function, is at least required to use the PROFINET IO device functions.

1.5 PROFINET IO controller/device functions

The master-slave procedure known from PROFIBUS was transferred to a provider-consumer model with PROFINET. A Provider generates and transmits data which the Consumer receives and processes. In terms of communication all devices in the PROFINET network have equal rights. The configuration specifies how the field devices are assigned to a central control system. PROFINET IO divides the control devices into IO controllers and IO devices. IO controllers are typically control systems (e.g., a central vehicle control).

The interface for IO devices was standardized by the PNO (Profibus User Organization) (PROFINET IO and GSD). This allows control systems from various manufacturers to communicate with IO devices. During configuration IO devices are assigned logically to an IO controller.

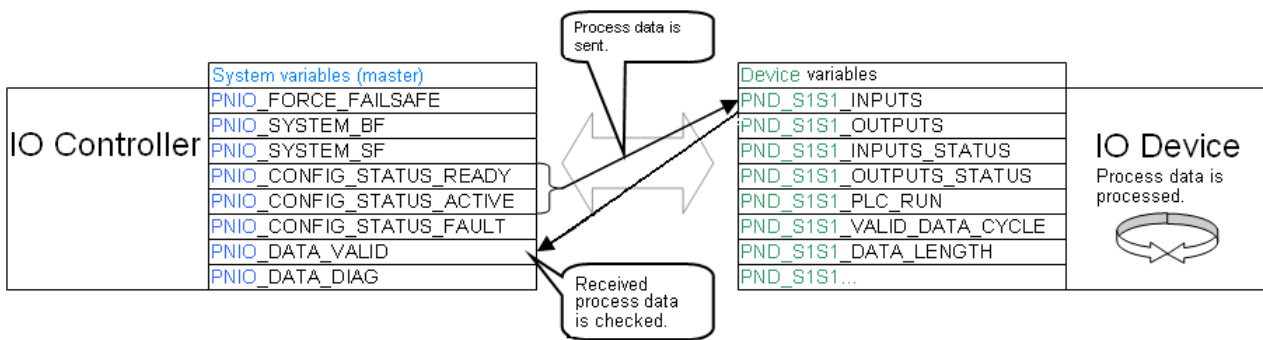

Figure 1-1 How communication works

PROFINET system variables (PROFINET IO controller)

| System variable | Type | Meaning |
|---------------------------|------|--|
| PNIO_FORCE_FAILSAFE | BOOL | All outputs are set to the safe state "0". |
| PNIO_CONFIG_STATUS | BOOL | Status of the active configuration in the context manager |
| PNIO_CONFIG_STATUS_ACTIVE | BOOL | Communication is active. |
| PNIO_CONFIG_STATUS_READY | BOOL | The context manager is active. |
| PNIO_SYSTEM_BF | BOOL | An error occurred in the PROFINET network, that means, there is no connection to at least one configured device. This value is not set if the "Drive BF" parameter was set to FALSE for a device. This device is removed from connection monitoring. |
| PNIO_SYSTEM_SF | BOOL | At least one device reported a system error (diagnostic alarm or maintenance alarm). |
| PNIO_DIAG_AVAILABLE | BOOL | At least one device reported a diagnostic alarm with an active connection. |
| PNIO_MAINTENANCE_REQUIRED | BOOL | At least one device reported the "maintenance demand" alarm with an active connection. |

UM EN PROFINET CTRL DEV

| | | |
|---------------------------|------|--|
| PNIO_MAINTENANCE_DEMANDED | BOOL | At least one device reported the "maintenance request" alarm with an active connection. |
| PNIO_DATA_DIAG | | If this bit is set, no device diagnostics is present. |
| PNIO_DATA_VALID | BOOL | The application program must receive information on whether a PROFINET IO device is supplying valid data or not. For this reason, the "PNIO_DATA_VALID" process data exists on each PROFINET IO device. Only if this bit is set does the PROFINET device supply valid data and all other process values are valid. |

PROFINET system variables (PROFINET IO device)

| System variable | Type | Meaning |
|-----------------------------|--|--|
| PND_S1S1_PLC_RUN | BOOL | Status of the higher-level control system/IO controller |
| PND_S1S1_VALID_DATA_CYCLE | BOOL | The higher-level control system/IO controller has established the connection. |
| PND_S1S1_OUTPUT_STATUS_GOOD | BOOL | I/O provider status of the higher-level control system/IO controller |
| PND_S1S1_INPUT_STATUS_GOOD | BOOL | I/O consumer status of the higher-level control system/IO controller |
| PND_S1S1_DATA_LENGTH | WORD | Process data length that was configured for the IO device. |
| PND_S1S1_OUTPUTS | PND_IO_512 [256] [128] [64] [32] | OUT process data Memory area for OUT process data that the IO device receives from the higher-level control system/IO controller. |
| PND_S1S1_INPUTS | PND_IO_512 [256] [128] [64] [32] | IN process data Memory area for IN process data that the IO device receives from the higher-level control system/IO controller. |

2 Network topologies

The following pages show three typical examples of network topologies. These topology examples are to explain the dependence and/or independence of the PROFINET IO controller/device functions.

The following hardware was used for the network structure:

| | |
|-----------------------|------------|
| ILC 330 PN | 2988191-03 |
| ILC 170 ETH 2TX | 2916532-04 |
| RFC 470 PN-3TX | 2916600-07 |
| FL SWITCH SMCS 4TX-PN | 2989093-06 |

2.1 Topology 1: Mechatronic unit with lower-level compact controllers

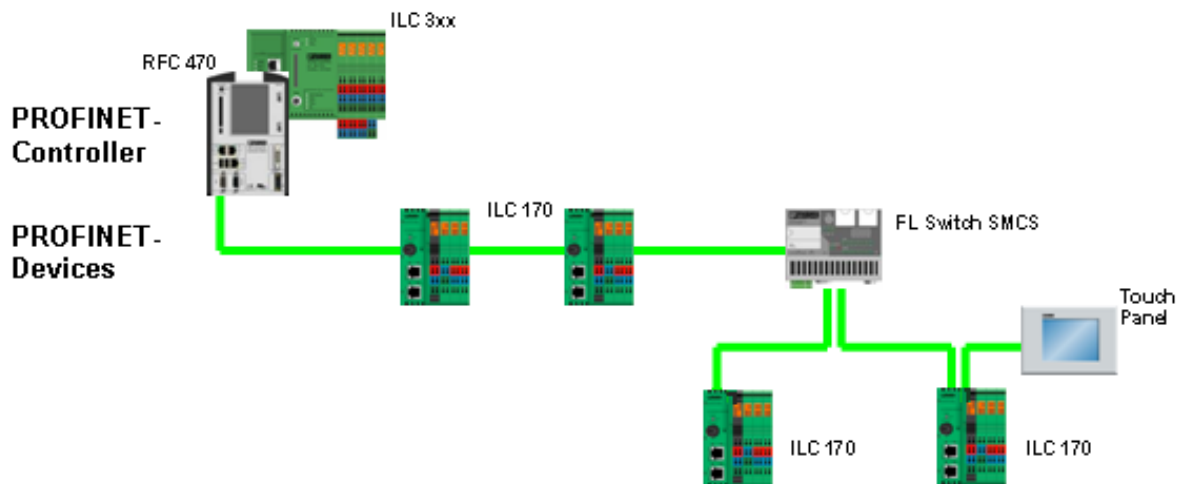

Figure 2-1 Topology 1: All devices in one network

Topology 1 describes a central concept with lower-level compact controllers. Every compact controller (ILC 1xx) is an independent PROFINET IO device and handles a local mechatronic unit with inputs and outputs. All controllers are available in a local network. Realtime communication over the central controller (RFC 470 PN-3TX, ILC 3xx) takes place over PROFINET. Controllers that are connected over a switch can be disconnected from the network at any time.

2.2 Topology 2: Four identical machine controllers under a machine park controller

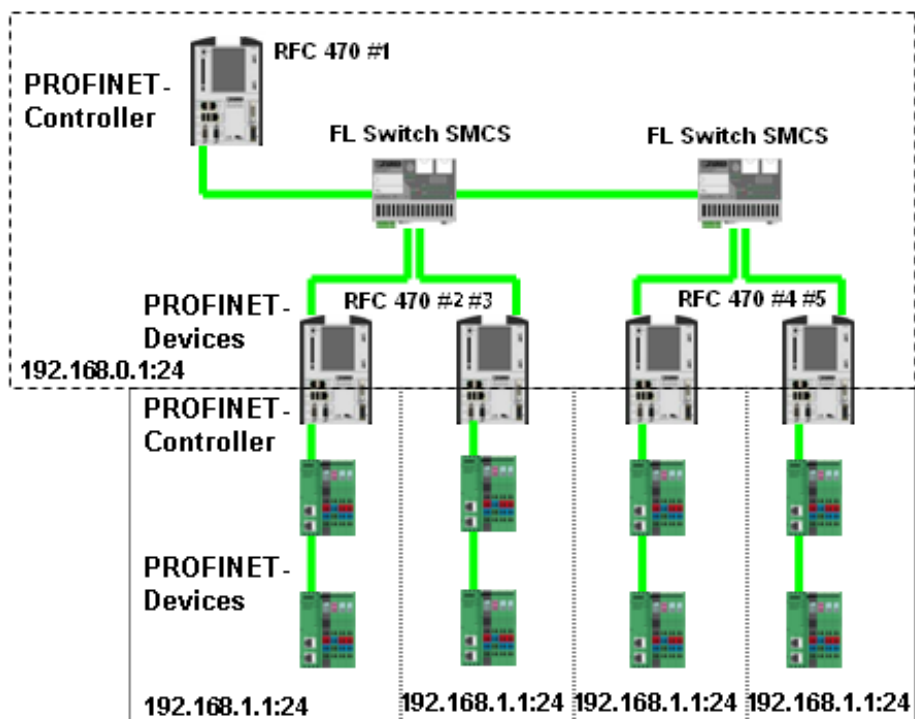

Figure 2-2 Topology 2: Devices in several networks

Topology 2 describes a central concept with lower-level machine controllers.

Every machine controller (RFC 470 #2, #3, #4, #5) comprises a PROFINET IO device. This machine controller comprises in parallel IO controllers with their own IO devices. The lower-level networks can use the identical IP address range since they are separated by the controller.

The RFC #1 controller as well as the RFCs #2, #3 and RFCs #4, #5 on the device side are located in a higher-level network. Being PROFINET IO devices, the individual I/Os are located in a lower-level network.

2.3 Topology 3: System control with lower-level subsystems

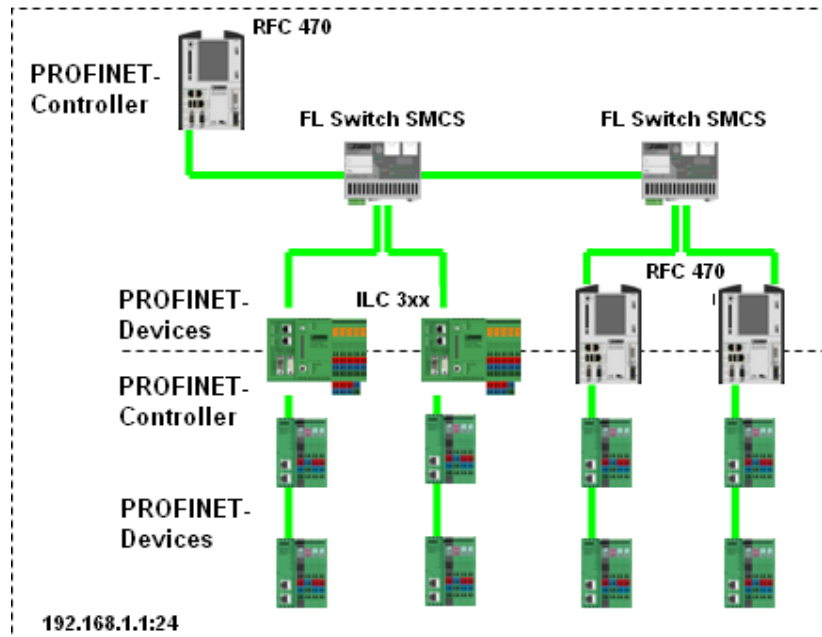

Figure 2-3 Topology 3: Devices in several networks

Topology 3 describes a central concept with lower-level system controllers. Every controller comprises a PROFINET IO device. This controller is also an IO controller with its own IO devices. All controllers and IO devices are located in one network.

UM EN PROFINET CTRL DEV

3 Description of a typical application (all devices in one network)

3.1 Information on how it was carried out

Alignment

The alignment of the data elements in the Inline controller memory can result in "data gaps" when storing data in the memory. The compiler automatically fills these gaps with padding bytes during the compiler process in order to prevent incorrect processing.

The disadvantage of the "automatic" filling of data gaps becomes apparent when data is transmitted from the Inline controller to another controller. If this controller does not know the memory algorithm of the Inline controller it will interpret the received data incorrectly.

It is therefore useful to program the filling of data gaps in your application program. Data transmissions to other controllers can thus be taken into consideration. For example, use byte arrays with an even number of bytes and/or word arrays in order to avoid data gaps in your application program.

The following should be taken into consideration when creating the program:

- Create data types in flat structures, i.e., do not nest user-defined data types.
- Insert padding bytes manually in order to ensure the uniform size and layout of the data types.
- When inserting padding bytes, please observe the memory alignment method of the controllers used in the application (1-byte, 2-byte or 4-byte alignment).

Programming example with data gaps

The following program example shows how data gaps are filled.

```

1  TYPE
2  Struct1 :
3  STRUCT
4      ByteElement :  BYTE;
5      WordElement :  WORD;
6  END_STRUCT;
7
8  Struct2 :
9  STRUCT
10     WordElement :  WORD;
11     ByteElement :  BYTE;
12 END_STRUCT;
13
14 Struct3 :
15 STRUCT
16     ByteElement1 :  BYTE;
17     ByteElement2 :  BYTE;
18 END_STRUCT;
19
20 Struct4 :
21 STRUCT
22     Struct2Element :  Struct2;
23     Struct3Element :  Struct3;
24 END_STRUCT;
25
26 Array1 :  ARRAY [0..1] OF Struct2;
27 END_TYPE

```

Size:

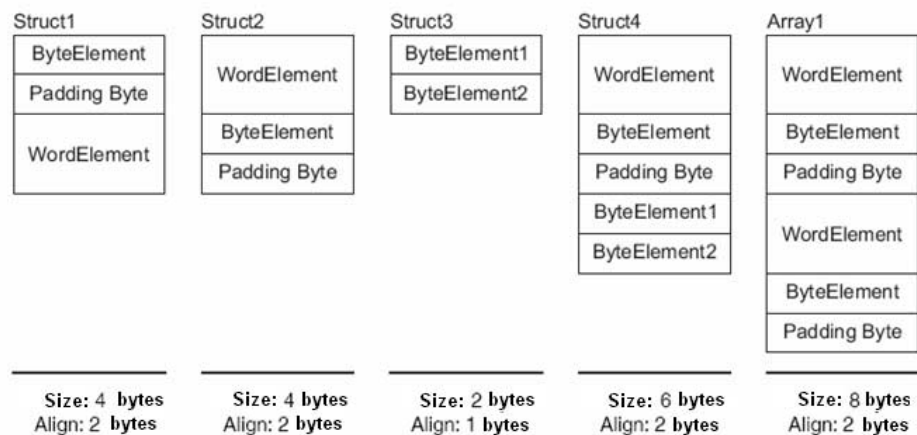

Figure 3-1 Programming example with data gaps

Struct1 receives a padding byte after the ByteElement so that the WordElement is at a WORD address (address that can be divided by 2 leaving no remainder). The alignment of the overall structure is based on the data type used with maximum alignment. In this case the WordElement specifies the alignment.

The size of Struct2 is calculated based on the elements used and the resulting alignment. The corresponding number of padding bytes is inserted so that the size of the data type with the value of the alignment can be divided by 2 leaving no remainder (data type size modulo alignment = 0).

Struct3 does not receive any padding bytes as the maximum alignment corresponds to one byte.

Due to the padding bytes that belong to the Struct2 structure, the Struct3 structure starts at an even address. The number of padding bytes in array 1 corresponds to that of two consecutive Struct2 structures.

Description of a typical application (all devices in one network)

Programming example without data gaps

The following program shows an example of how data gaps may be filled in your application program. Fill data gaps, which are to be expected due to the memory alignment, with application data.

```

1  TYPE
2  Struct1 :
3  STRUCT
4      ByteElement : BYTE;
5      ByteElement : BYTE; (*Padding-Byte*)
6      WordElement : WORD;
7  END_STRUCT;
8
9  Struct2 :
10 STRUCT
11     WordElement : WORD;
12     ByteElement : BYTE;
13     ByteElement : BYTE; (*Padding-Byte*)
14 END_STRUCT;
15
16 Struct3 :
17 STRUCT
18     ByteElement1 : BYTE;
19     ByteElement2 : BYTE;
20 END_STRUCT;
21
22 STRUCT4 :
23 STRUCT
24     Struct2Element : Struct2;
25     Struct3Element : Struct3;
26 END_STRUCT;
27
28 Array1 : ARRAY [0..1] OF Struct2;
29 END_TYPE
    
```

Figure 3-2 Programming example without data gaps

3.2 Typical application

In the following application all devices are in one network, see also the topology example on page 2-1.

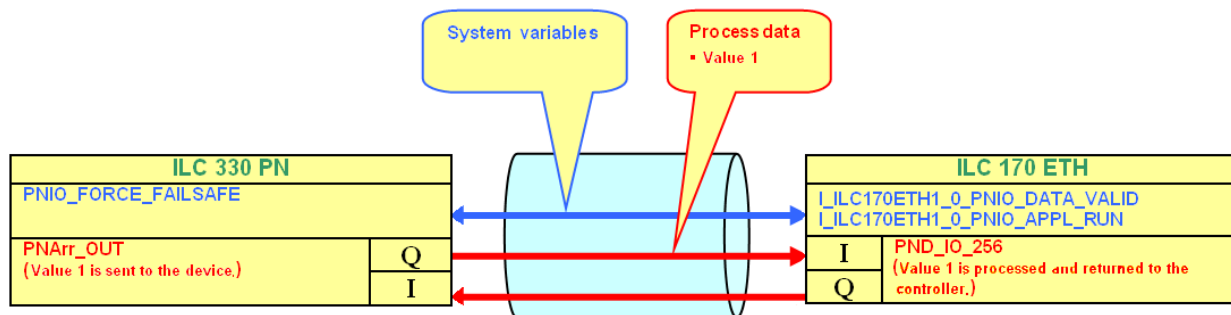

Figure 3-3 Typical application

UM EN PROFINET CTRL DEV

The following devices are used for this application:

| Device | Order No. | IP address |
|--------------------------------|-----------|--------------|
| ILC 330 PN as master | 2988191 | 192.168.0.5 |
| ILC 170 ETH 2TX as device | 2916532 | 192.168.0.7 |
| FL SWITCH SMCS 4TX (optional) | 2989093 | |
| Notebook as programming device | | 192.168.0.10 |

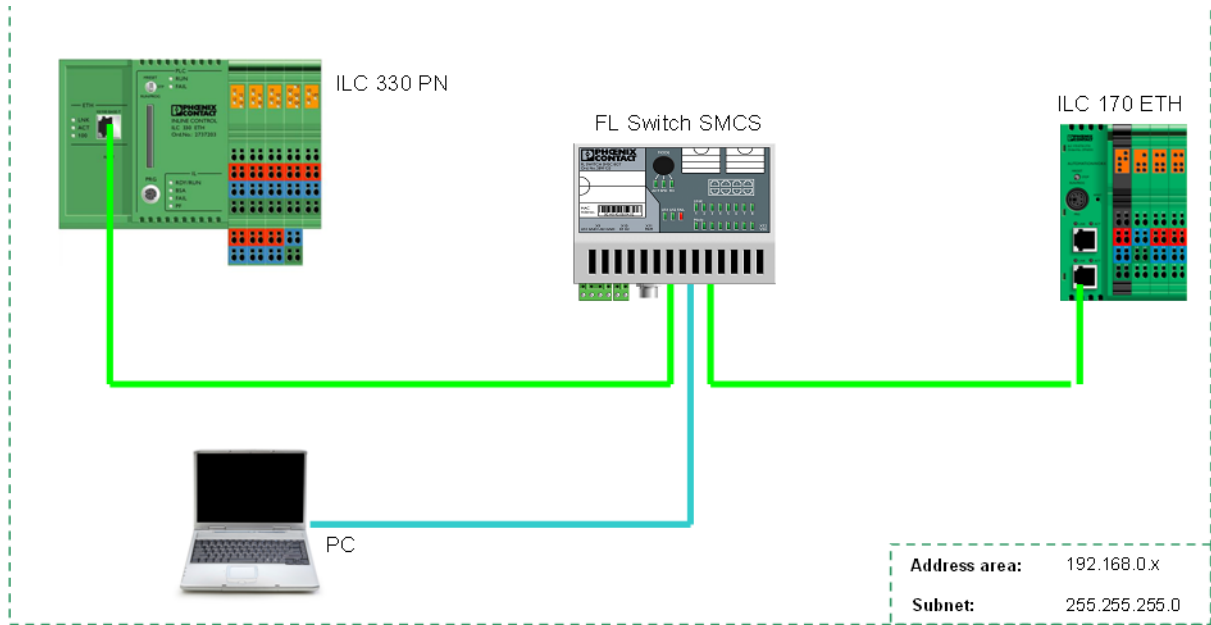

Figure 3-4 Typical application, all devices in one network

In this example, a project is created on the lower-level controller (ILC 170 PN) by requesting the status variables of PROFINET communication (PND_S1S1). For this purpose, a function block is created in structured text that sets the value "true" on the ONBOARD_OUTPUT_BIT0 system variable. The LED is ON when the ILC 330 PN sends the value "1".

In the example, a function block is used for logical ANDing. The I_ILC170ETH1_0_PNIO_DATA_VALID and I_ILC170ETH_0_PNIO_APPL_RUN variables (both system variables) map the status of the inputs to which the PNIO_FORCE_FAILSAFE system variable is connected.

The PNIO_DATA_VALID system variable indicates for each PROFINET IO device whether the connection to this PROFINET IO device was established successfully. Only if this bit is set does the PROFINET IO device supply valid data and all other process values are active.

A negated result is linked to the PNIO_FORCE_FAILSAFE variable. The PROFINET system is stable when the system variable PNIO_FORCE_FAILSAFE = 0. All outputs are set according to the process data. If PNIO_FORCE_FAILSAFE = 1 (at least one PNIO_DATA_VALID variable set to 0), the safe state "0" is output for all PROFINET IO device outputs.

Description of a typical application (all devices in one network)

In addition, the value 1 is assigned to the PNArr_OUT[0] variable (user variable). This is done via the negated status of the PNIO_FORCE_FAILSAFE system variable. The value 1 is converted in the BYTE data type, since the PROFINET IO process data (PND_IO_256) are assigned as ARRAY OF BYTE data type for the variable.

3.3 Offline configuration

3.3.1 Lower-level project

- Select the "New Project..." command from the "File" menu to create a new project using a template.

The tree structure and the selection of the control system are now prepared.

- Select the "ILC 170 ETH Rev. >01/3.50" control system and confirm your selection with "OK".

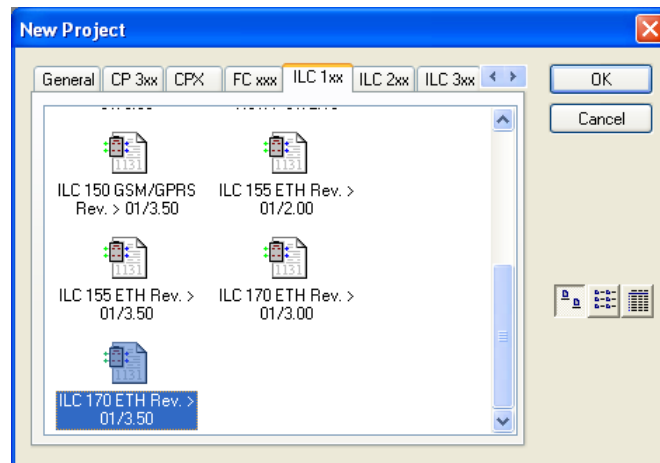

Figure 3-5 Selecting the controller

- Select the "File, Save Project As/Zip Project As..." command.
- Enter a project name (here: ILC170_Device) and save the project.

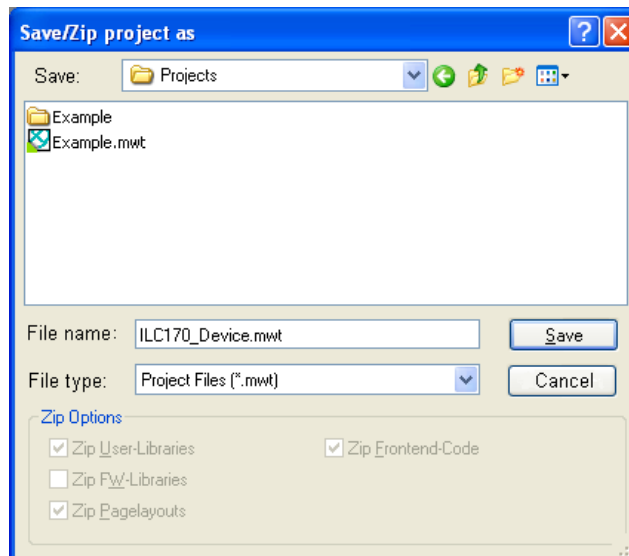

Figure 3-6 Save project

Description of a typical application (all devices in one network)

The following window opens:

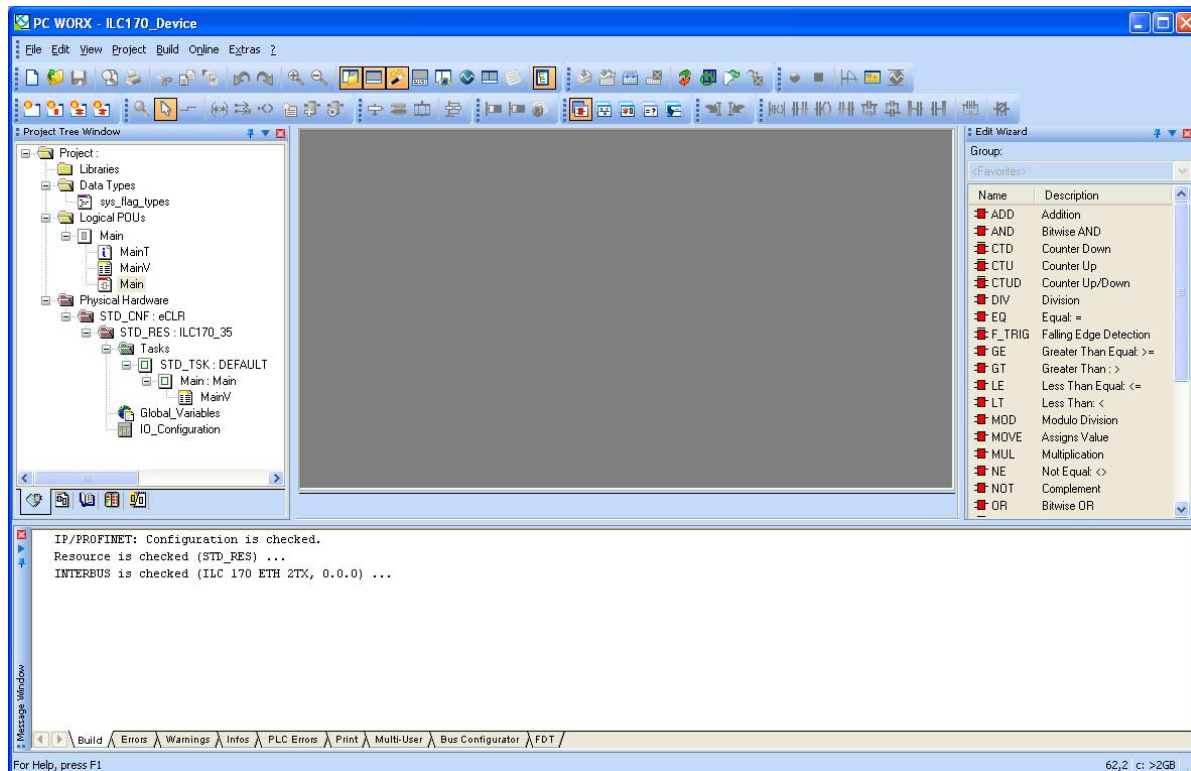

Figure 3-7 PC WorX start screen

- Right-click on Logical POU's.
- Insert the function block.

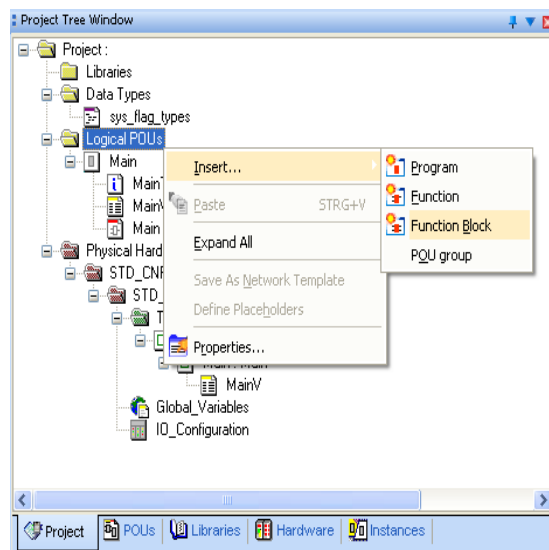

Figure 3-8 Inserting the function block

UM EN PROFINET CTRL DEV

- Select the ST (Structured Text) language.
- Name the block "Data_Acknowledge".

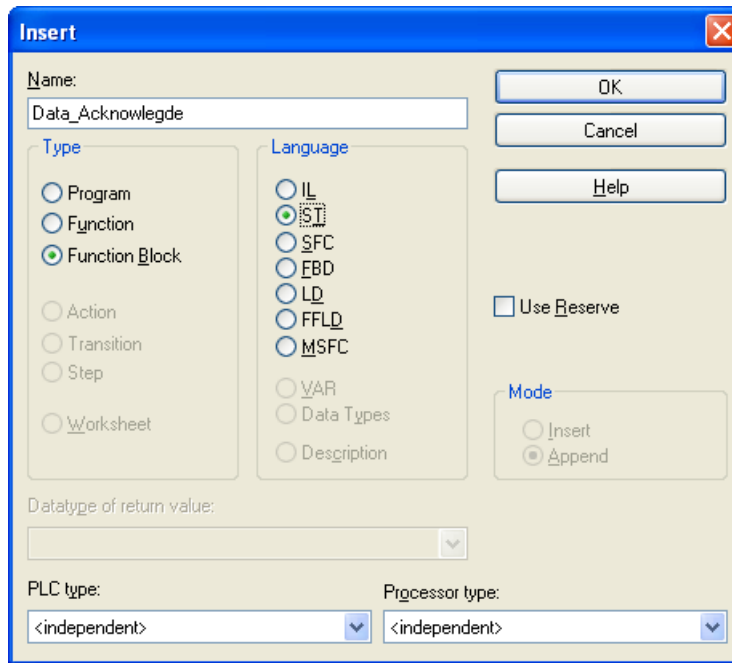

Figure 3-9 Selecting the programming language and naming the function block

- Open the worksheet by double-clicking on "Data_Acknowledge".

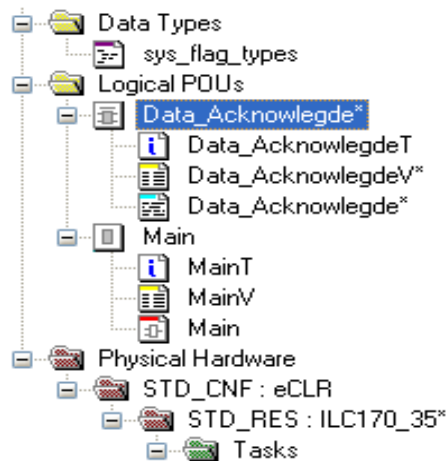

Figure 3-10 Opening the worksheet

Description of a typical application (all devices in one network)

- Insert the following program to your worksheet.

```

1  ONBOARD_OUTPUT_BIT0 := FALSE;
2
3  if
4      BYTE_TO_INT(PND_S1S1_INPUTS[0]) = 1
5
6      then
7          ONBOARD_OUTPUT_BIT0 := TRUE;
8
9  end_if;
10

```

Figure 3-11 Inserting the program

The ONBOARD-OUTPUT_BIT0 system variable and the PROFINET IO device status variable PND_S1S1_INPUTS for the process data can be found under the **Global_Variables**.

- Select the maximum process data length of 256 bytes (PND_IO_256) for the data exchange between master and device.

| Name | Typ | Verwendung | Beschreibung | |
|--------------------------|------------|------------|---|------|
| ONBOARD_INPUT_BIT2 | BOOL | VAR_GLOBAL | Local input IN3 | %M |
| ONBOARD_INPUT_BIT3 | BOOL | VAR_GLOBAL | Local input IN4 | %M |
| ONBOARD_INPUT_BIT4 | BOOL | VAR_GLOBAL | Local input IN5 | %M |
| ONBOARD_INPUT_BIT5 | BOOL | VAR_GLOBAL | Local input IN6 | %M |
| ONBOARD_INPUT_BIT6 | BOOL | VAR_GLOBAL | Local input IN7 | %M |
| ONBOARD_INPUT_BIT7 | BOOL | VAR_GLOBAL | Local input IN8 | %M |
| ONBOARD_OUTPUT_BIT0 | BOOL | VAR_GLOBAL | Local output OUT1 | %M |
| ONBOARD_OUTPUT_BIT1 | BOOL | VAR_GLOBAL | Local output OUT2 | %M |
| ONBOARD_OUTPUT_BIT2 | BOOL | VAR_GLOBAL | Local output OUT3 | %M |
| RTC_DAY | INT | VAR_GLOBAL | System time (day) | %M |
| RTC_YEAR | INT | VAR_GLOBAL | System time (year) | %M |
| PND_S1S1_PLC_RUN | BOOL | VAR_GLOBAL | Status of the higher-level control system | %IX |
| PND_S1S1_VALID_DATA... | BOOL | VAR_GLOBAL | IO Controller has established the connection | %IX |
| PND_S1S1_OUTPUT_STAT... | BOOL | VAR_GLOBAL | IOP status of the higher-level control system | %IX |
| PND_S1S1_INPUT_STATUS... | BOOL | VAR_GLOBAL | IOC status of the higher-level control system | %IX |
| PND_S1S1_DATA_LENGTH | WORD | VAR_GLOBAL | Process data length | %M |
| PND_S1S1_OUTPUTS | PND_IO_256 | VAR_GLOBAL | Output process data | %QI |
| PND_S1S1_INPUTS | PND_IO_256 | VAR_GLOBAL | Input process data | %IPI |
| IB_DEVICE_PARAM_ACTIV... | BOOL | VAR_GLOBAL | Interbus device configuration activated | %M |
| IB_DEVICE_PARAM_READY | BOOL | VAR_GLOBAL | Interbus device configuration completed | %M |
| IB_DEVICE_PARAM_ERROR | BOOL | VAR_GLOBAL | Interbus device configuration error | %M |

Figure 3-12 Selecting the process data

UM EN PROFINET CTRL DEV

- Afterwards insert the created function block in the "Main" worksheet using drag & drop.

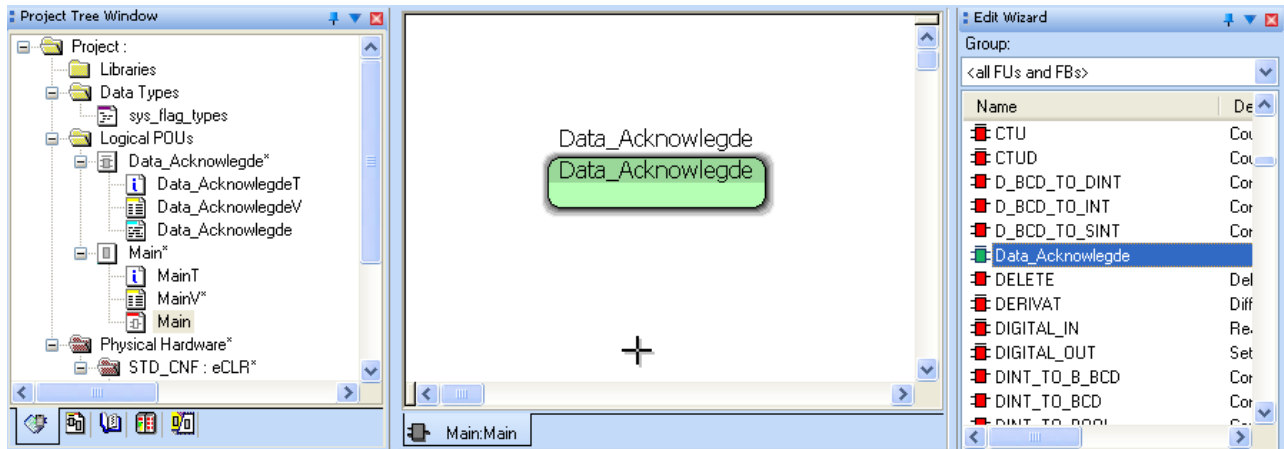

Figure 3-13 Inserting the function block into the worksheet

- Compile the project and save it.
- Close the project.

Description of a typical application (all devices in one network)

3.3.2 Higher-level project

- Select the "New Project..." command from the "File" menu to create a new project using a template.

The tree structure and the selection of the control system are now prepared.

- Select the "ILC 330 PN Rev. > 01/4.6F/3.50" control system and confirm your selection with "OK".

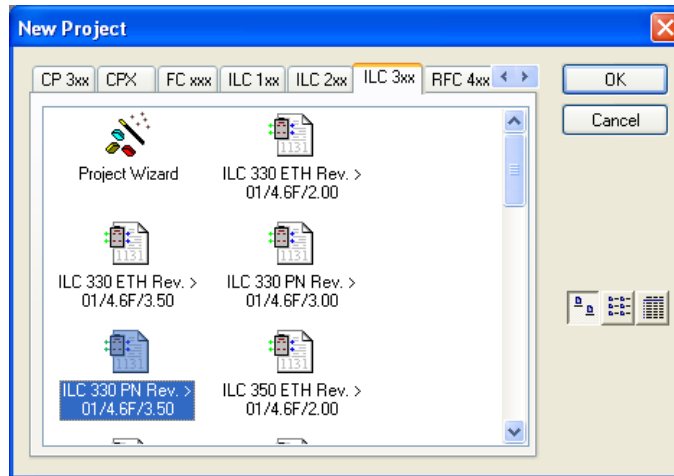

Figure 3-14 Selecting the controller

- Select the "File, Save Project As/Zip Project As..." command.
- Enter a project name (**here: ILC330_Controller**) and save the project.

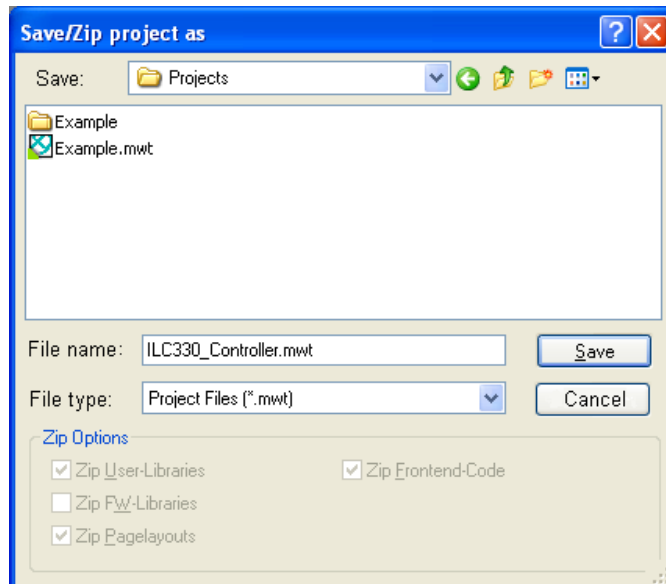

Figure 3-15 Save project

UM EN PROFINET CTRL DEV

The following window opens:

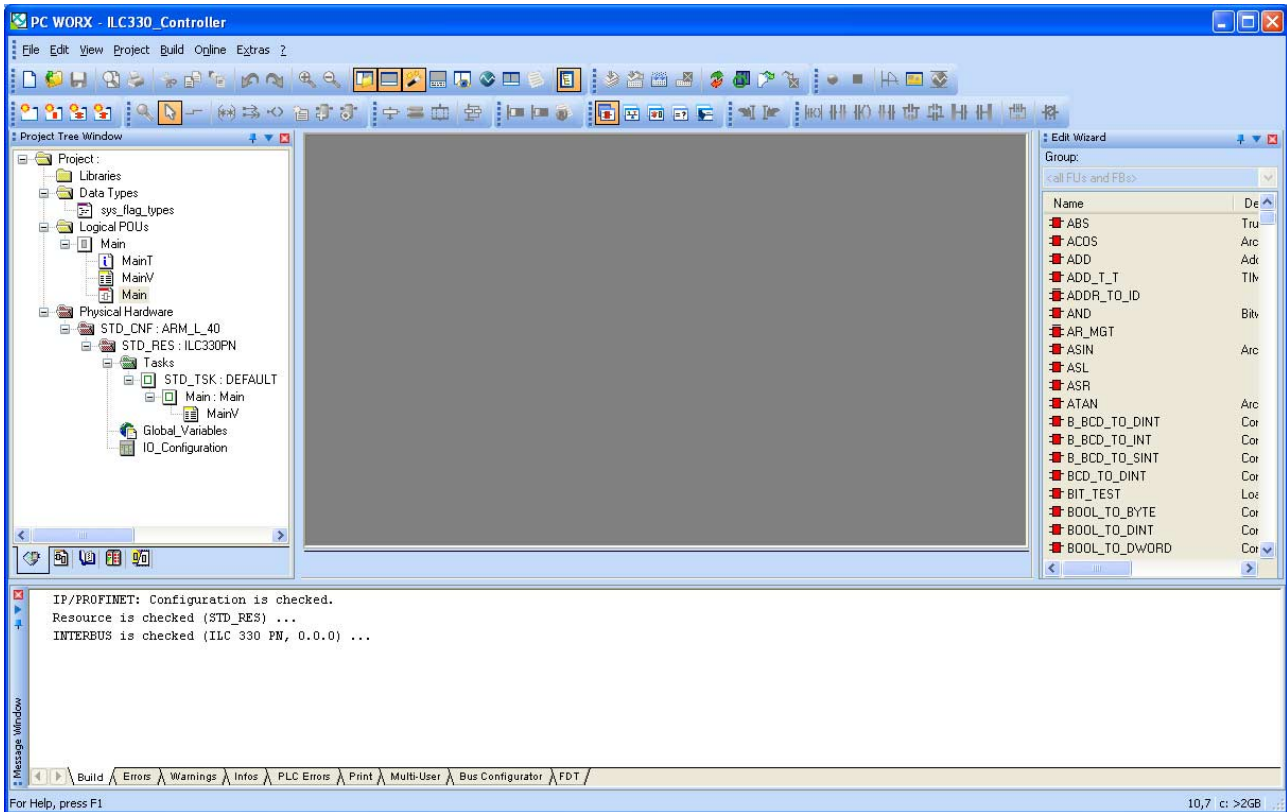



Figure 3-16 Start screen

Description of a typical application (all devices in one network)

- First integrate the ILC 170 ETH 2TX as a PROFINET IO device into the bus structure.
- Change to the bus structure. To do this, click on the "Bus Structure" icon in the toolbar. 
- Insert the ILC 170 ETH 2TX as a device into the bus structure (right click).

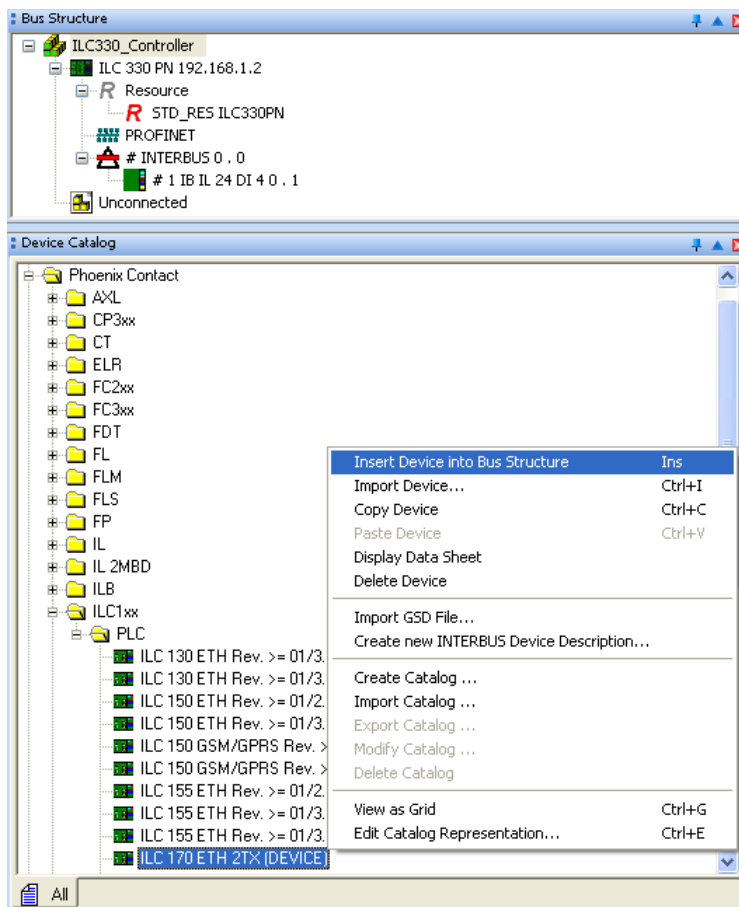

Figure 3-17 Inserting the ILC 170 ETH 2TX as a device in the bus structure

UM EN PROFINET CTRL DEV

The PROFINET device inserted will be displayed in the Bus Structure workspace. The IP address is created depending on the IO controller address.

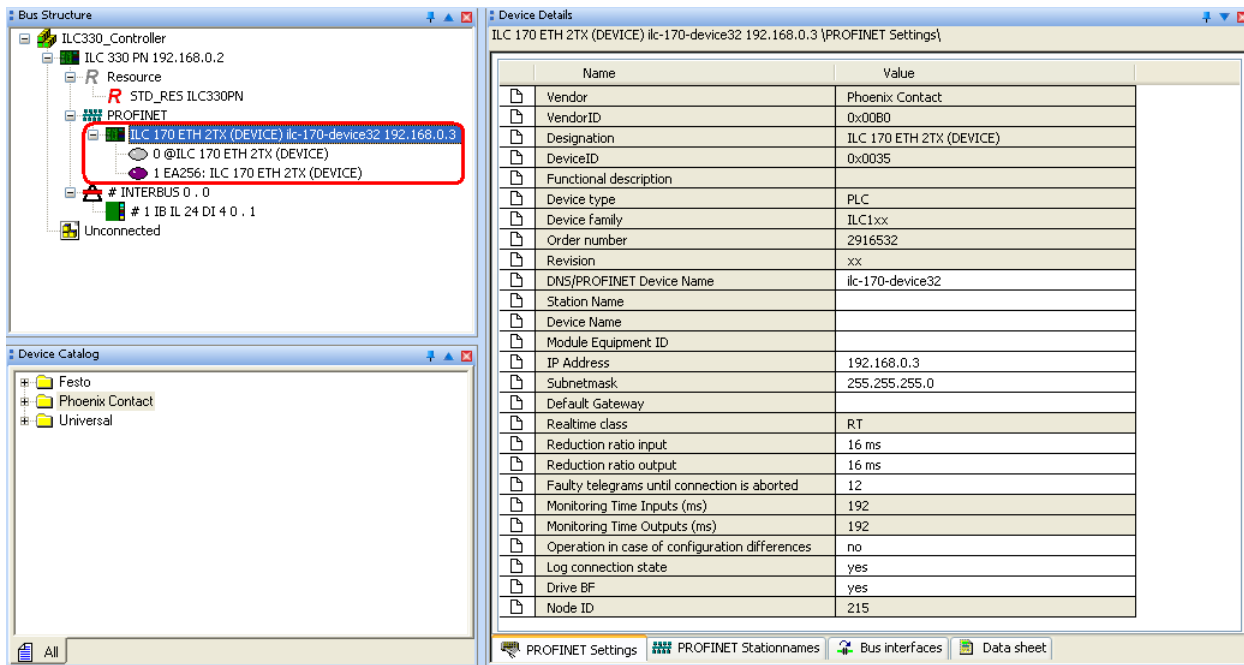

Figure 3-18 The ILC 170 ETH 2TX integrated as PROFINET device in the bus structure

The process data of the PROFINET device will be displayed in the Device Details workspace of the "Process Data" tab.

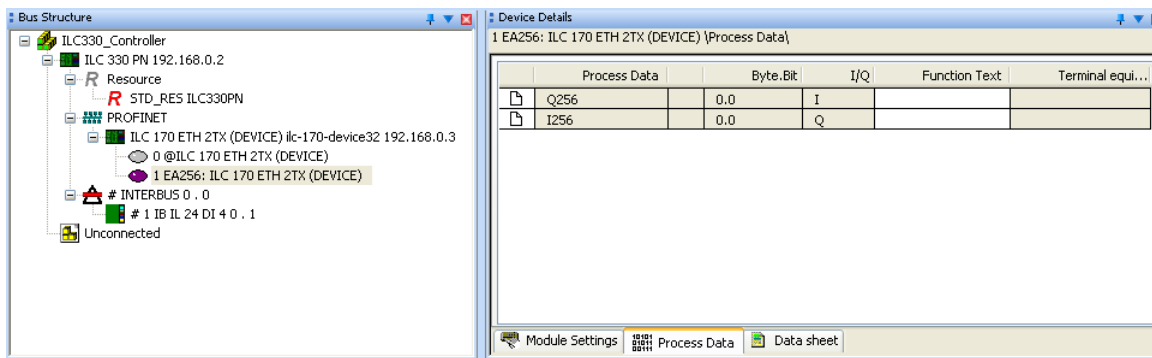



Figure 3-19 Process data of the PROFINET device

Description of a typical application (all devices in one network)

- Switch to the IEC programming  and open the "Main" worksheet.
- Add the mapped function blocks.
- Negate the output at the AND block.

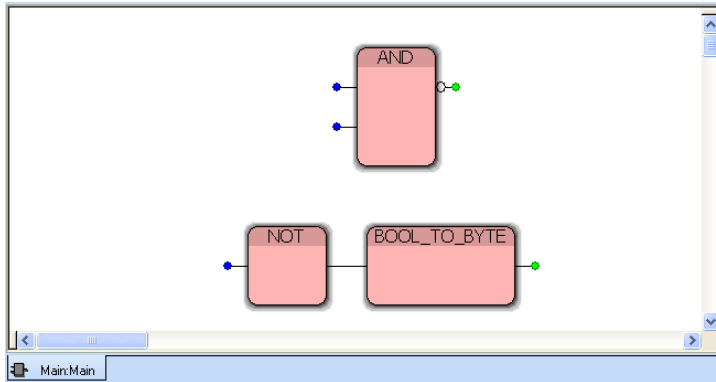

Figure 3-20 Adding function blocks

For the system variables for displaying the status of a PROFINET IO device, the process data is generated automatically.

- Switch to the process data assignment workspace.
- In the top left window, "Symbols/Variables", select the program (here: Main : Main).
- Highlight the PROFINET IO device in the top right window.
- Highlight the PNIO_APPL_RUN variable in the bottom right window.
- Enable the context menu on the variable and select the "Create Variable" command. In this case, a variable is generated automatically.
- Proceed in the same way for the PNIO_DATA_VALID variable.

The screenshot shows the 'Process Data Assignment' workspace. On the left, the 'Symbols/Variables' tree is expanded to 'Main : Main'. On the right, the 'ILC330_Controller' tree is expanded to show the 'PROFINET' section. Below these trees is a table with columns: 'Device', 'Process Data Item', 'I/Q', and 'Data Type'. The table lists several variables for the 'ILC 170 ETH 2TX (DEVICE)'.

| Device | Process Data Item | I/Q | Data Type |
|-----------------------------------|-------------------|-----|-----------|
| 0 @ILC 170 ETH 2TX (DEVICE) | ~PNIO_DATA_STATE | I | BYTE |
| 0 @ILC 170 ETH 2TX (DEVICE) | PNIO_IS_PRIMARY | I | BOOL |
| 0 @ILC 170 ETH 2TX (DEVICE) | PNIO_DATA_VALID | I | BOOL |
| 0 @ILC 170 ETH 2TX (DEVICE) | PNIO_APPL_RUN | I | BOOL |
| 0 @ILC 170 ETH 2TX (DEVICE) | PNIO_NO_DIAG | I | BOOL |
| 1 EA256: ILC 170 ETH 2TX (DEVICE) | Q256 | | |
| 1 EA256: ILC 170 ETH 2TX (DEVICE) | I256 | | |

A context menu is open over the 'PNIO_APPL_RUN' row, with 'Create Variable' selected. The menu also includes options like 'Select all', 'Search...', 'Filter', 'Color-coded view', 'Connect', 'Disconnect', 'Search Variable', and 'Search Cross Reference'.

Figure 3-21 Creating variables

UM EN PROFINET CTRL DEV

- In addition, create the "PNArr_Out" variable with the "PND_IO_256" data type as "VAR-EXTERNAL".

| Name | Typ | Verwendung | Beschreibung |
|--------------------------------|------------|-----------------|--|
| Default | | | |
| PNArr_Out | PND_IO_256 | VAR_EXTERNAL | |
| I_ILC170ETH1_0_PNIO_APPL_RUN | BOOL | VAR_EXTERNAL_PG | |
| I_ILC170ETH1_0_PNIO_DATA_VALID | BOOL | VAR_EXTERNAL_PG | |
| PNIO_FORCE_FAILSAFE | BOOL | VAR_EXTERNAL | All PROFINET devices are prompted to set th... |

Figure 3-22 Creating the "PNArr_Out" variable

- To link the process data to the variables, proceed as follows:
- In the top left window (Symbols/Variables) select "Default".
- Highlight the PROFINET IO controller in the top right window.
- Highlight the "ILC 170 ETH ..." variable in the bottom right window.
- Connect the "PNArr_Out" variable to the "I256" process data item of the ILC 170 ETH 2TX device.

The total available data width of 256 bytes was selected in this example. You can change it later in the online configuration.

| Symbol/Variable | Data Type | Process Data Item | Device | Process Data Item | I/Q | Data Type |
|-----------------|------------|-------------------|-----------------------------------|-------------------|-----|-----------|
| PNArr_Out | PND_IO_256 | | 1 EA256: ILC 170 ETH 2TX (DEVICE) | I256 | Q | Byte_256 |

Figure 3-23 Connecting the "PNArr_Out" variable to the process data

Description of a typical application (all devices in one network)

- Switch to IEC programming and link the variables as shown in the figure below.
- Add a negation to the output of the AND block.

The "PNIO_FORCE_FAILSAFE" system variable is used at the output of the AND block and the input of the "NOT" block.

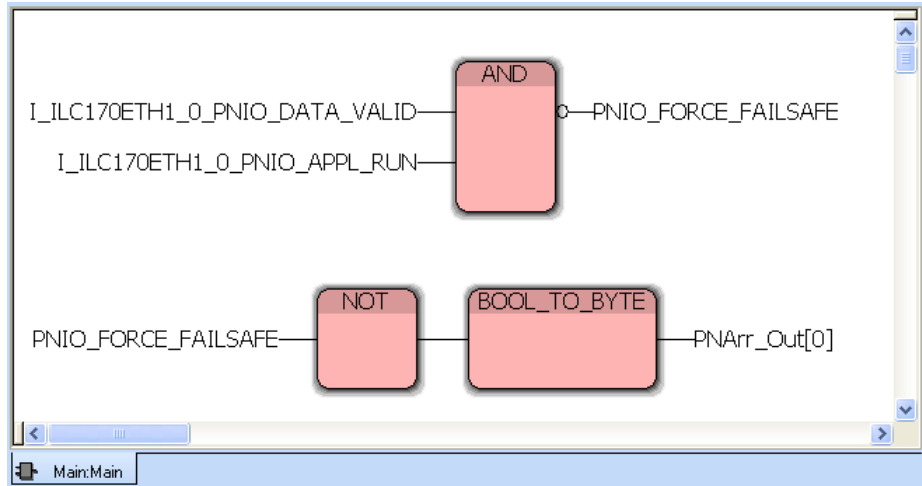

Figure 3-24 Inserting and linking variables

- Select the "0" array in the byte array by writing the field "[0]" after the "PNArr_Out" variable.
- Then compile the project and save it.

3.4 Online configuration

3.4.1 Preparing the PC for communication

- For configuration and parameterization assign an appropriate IP address for your PC within the 192.168.0.x address area.

In this example the PC receives the address 192.168.0.10.

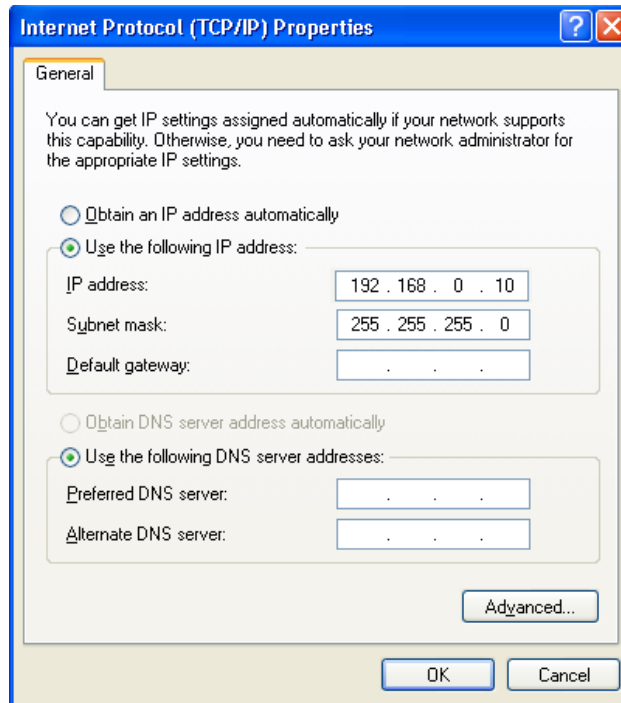

Figure 3-25 Assigning an IP address

- Select the network card of your PC that is to be used for communication in the "Tools/PROFINET..." menu of PC WorX.

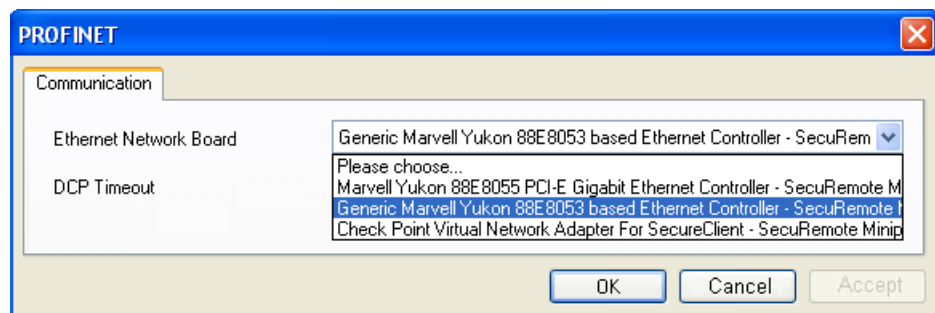

Figure 3-26 Selecting the network card

Now the PC is ready for communications within the subnet.

Description of a typical application (all devices in one network)

3.4.2 Configuring the ILC 170 ETH 2TX

Assigning IP settings

To set the IP address in PC WorX proceed as described below:

- Open your project "ILC170_Device".
- Establish an Ethernet connection between your PC and the controller.
- In the PC WorX menu bar, select the "Extras... BootP/SNMP/TFTP-Configuration..." menu.

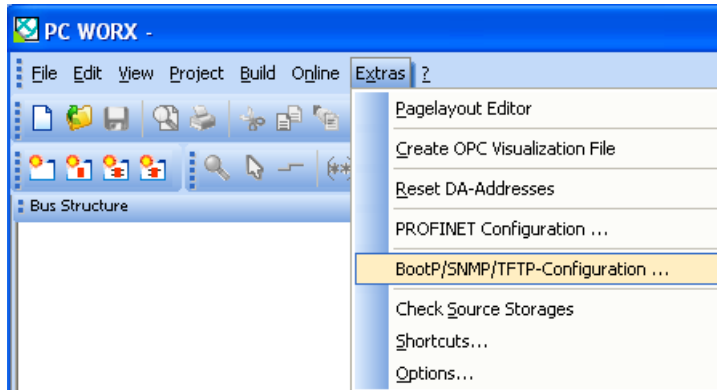

Figure 3-27 Selecting "Extras/BootP/SNMP/TFTP-Configuration..."

- Activate the "BootP server active" checkbox.

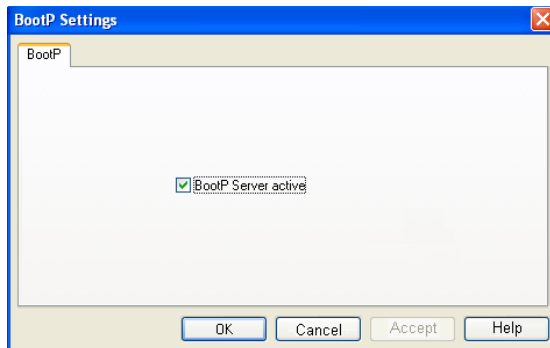

Figure 3-28 Activate BootP server

- Switch to the bus configuration workspace, see Figure 3-30
- Select the controller node.
- Select the "IP Settings" tab in the "Device Details" window.
- Enter the MAC address of the controller. It is printed on the device and starts with 00.A0.45.

UM EN PROFINET CTRL DEV

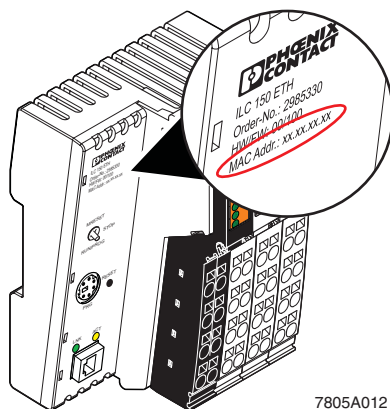

Figure 3-29 Printed MAC address on the ILC 150 ETH controller

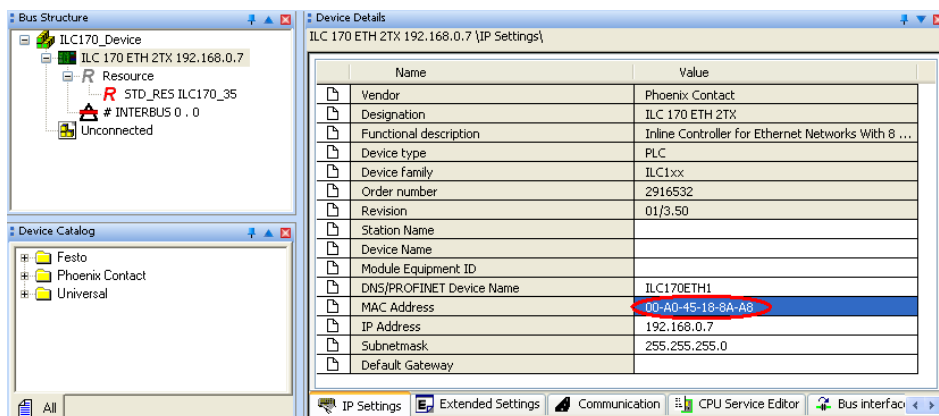

Figure 3-30 Entering the IP address

- Perform a cold restart for the controller.
- To do this, switch the supply voltage off and then on again after around 2 seconds.

The controller is assigned the IP address, which is specified in the project for the controller (here: 192.168.0.7). The following message appears in the message window in the "Bus Configurator" tab.

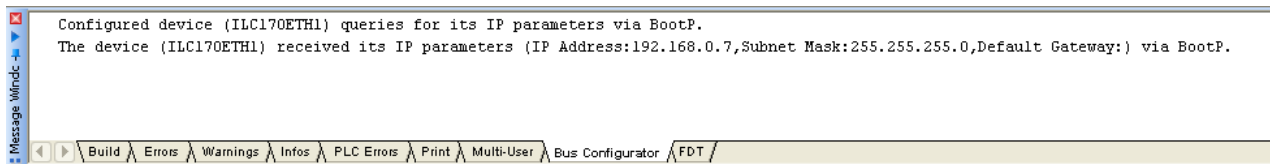

Figure 3-31 Message window

The IP address will now be permanently stored on the controller Flash memory.

Description of a typical application (all devices in one network)

Switching on the PROFINET IO device function



The following applies to the devices:
ILC 170/330/350/370/390 PN / RFC 470 PN-3TX

By default upon delivery the PROFINET IO device function is switched off for every controller.

- Switch to the "Extended Settings" tab.
- Select the "IO device status" item in the device details under "Network Settings".
- Under "Settings", select "activated" in the pull-down menu.

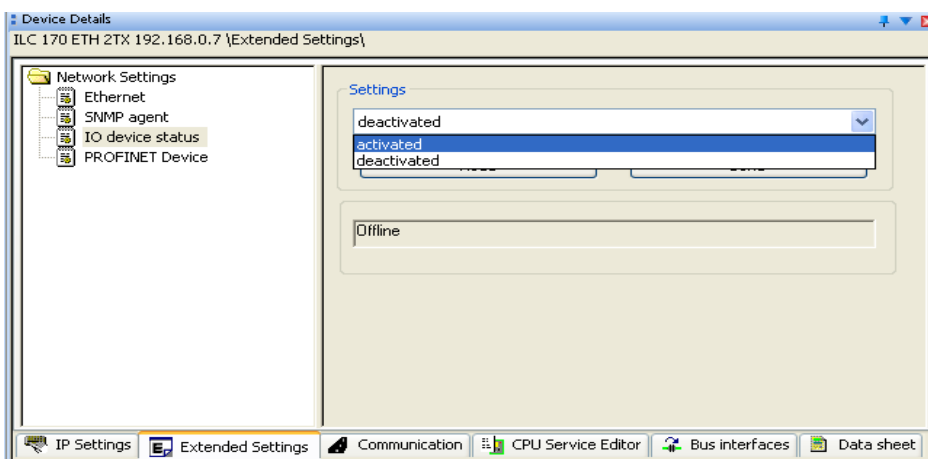

Figure 3-32 Device function activated

- Click on "Transmit".
- In the "Settings Communication Path" dialog confirm with "OK" the suggested IP address or the one you have selected for your application.

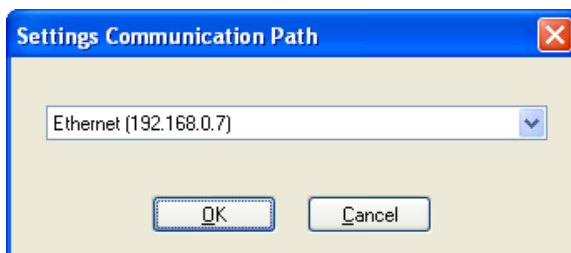

Figure 3-33 Setting the communication path

UM EN PROFINET CTRL DEV

Successful execution of the service will be displayed in the status window.

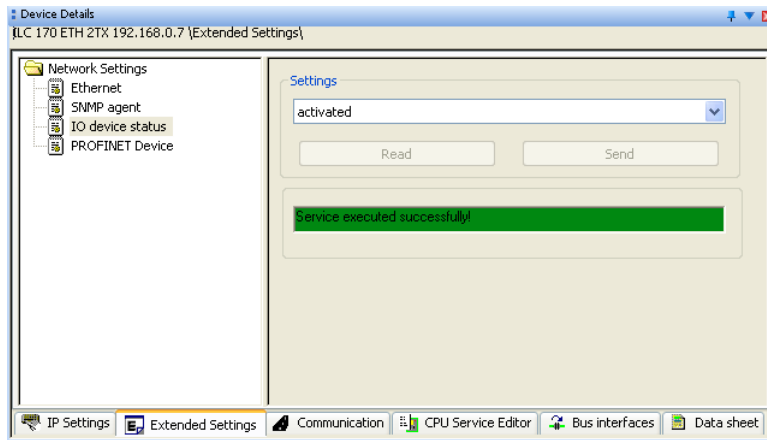

Figure 3-34 Status window

To transfer the network settings you have to reset the IO controller.

- Select the "Ethernet" item in the Device Details window under "Network Settings".



The device name in the higher-level project (ILC 170 ETH device) must match the device name of the lower-level project (ILC 170 ETH).

- In the "Activate Network Settings" area click the "Reset Control System" button.

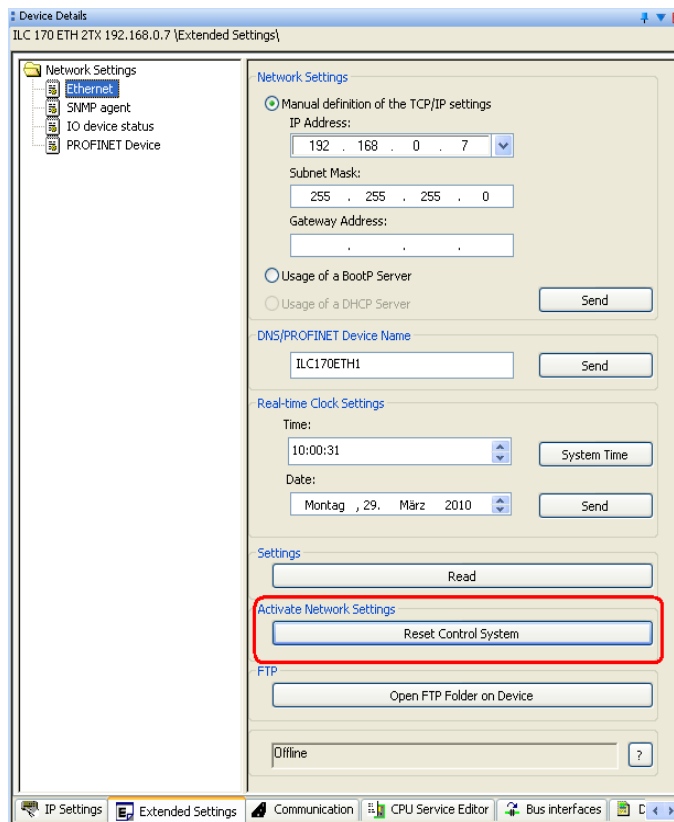

Figure 3-35 Resetting the controller

Description of a typical application (all devices in one network)

- In the "Settings Communication Path" dialog confirm with "OK" the suggested IP address or the one you have selected for your application.

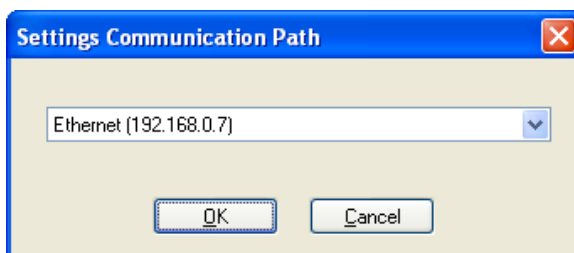

Figure 3-36 Setting the communication path

Successful execution of the service will be displayed in the status window.

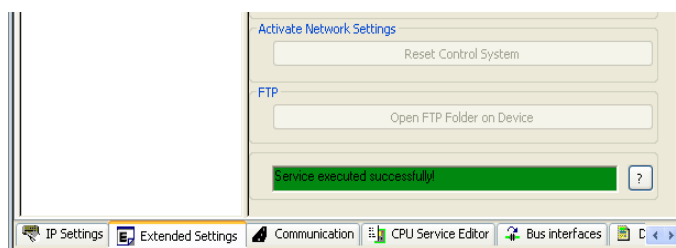

Figure 3-37 Status window

The input/output data ranges available for the ILC 170 ETH 2TX as PROFINET IO device are displayed under "Network Settings" -> "PROFINET Device".

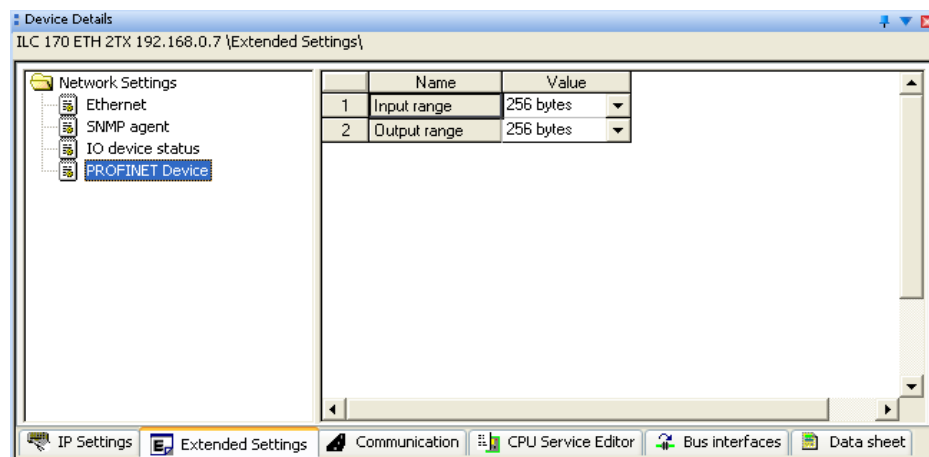

Figure 3-38 Input/output data ranges

UM EN PROFINET CTRL DEV

To set the task to update the I/Os, select the device resource in the Bus Structure window.

- Set the update task to "DEFAULT".

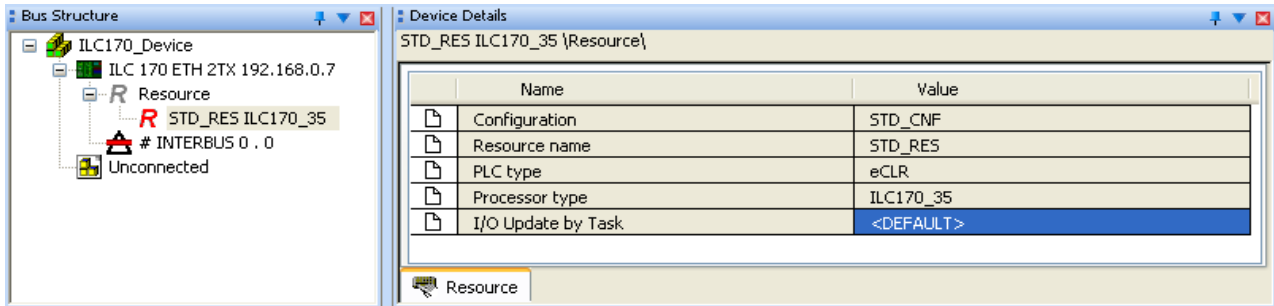

Figure 3-39 Setting the update task

3.4.3 Configuring the ILC 330 PN

To configure the ILC 330 PN controller, proceed as described in Section "Configuring the ILC 170 ETH 2TX" on page 3-19.

Assigning IP settings

Open the higher-level project "ILC330_Controller" and proceed as described in Section "Configuring the ILC 170 ETH 2TX" on page 3-19.

Please not the following modifications:

- Enter the MAC address of the ILC 330 PN controller.
- Assign the IP address 192.168.0.2.

To use the PROFINET device functions, the following conditions apply for the "ILC330_Controller" project.

ILC 330 PN settings as PROFINET controller:

IP address: 192.168.0.2
 Subnet mask 255.255.255.0
 PROFINET device name: ILC330PN1

ILC 170 ETH 2TX settings as PROFINET IO device:

IP address: 192.168.0.7
 Subnet mask 255.255.255.0
 PROFINET device name: ILC170ETH1



Please make sure that the same PROFINET device name of the ILC 170 ETH (here: ILC170ETH1) is used in the lower-level project as in the higher-level project for the ILC 170 ETH as a device (here: ILC170ETH1).

Description of a typical application (all devices in one network)

3.4.4 Observe startup behavior

Starting up the controller is the easiest way to check whether

- The controller is correctly parameterized
- The IO devices have the right name
- There are double names or double IP addresses in the system.

Compile the ILC330_Controller project with the bus configuration. There will be a warning message if there is no application program. You can ignore this message.

Make sure that the controller has the IP address that was set in the project. Start the project control dialog via the menu bar.

If the message "Timeout" appears after 10 seconds, the project and device addresses do not match. It is also possible that the IP address of the computer has not been set correctly.

The controller can be reset from the project control dialog. The existing project will be deleted. Start the download and perform a cold reset. Afterwards the BF LEDs must go out on all devices.

To access the network status from the program, the following system variables are mapped in the global variables of the programming environment. Activate the "Debug On" operating mode and the values of these variables will be displayed.

| Global variable | Description |
|---------------------------|---|
| PNIO_CONFIG_STATUS_ACTIVE | Connection to these devices is being established or has been completed. |
| PNIO_CONFIG_STATUS_READY | The connection establishment to the devices has been completed. |

3.4.5 Checking the program start of the higher-level project

When the program is started correctly, the following screen will be shown in the Debug mode:

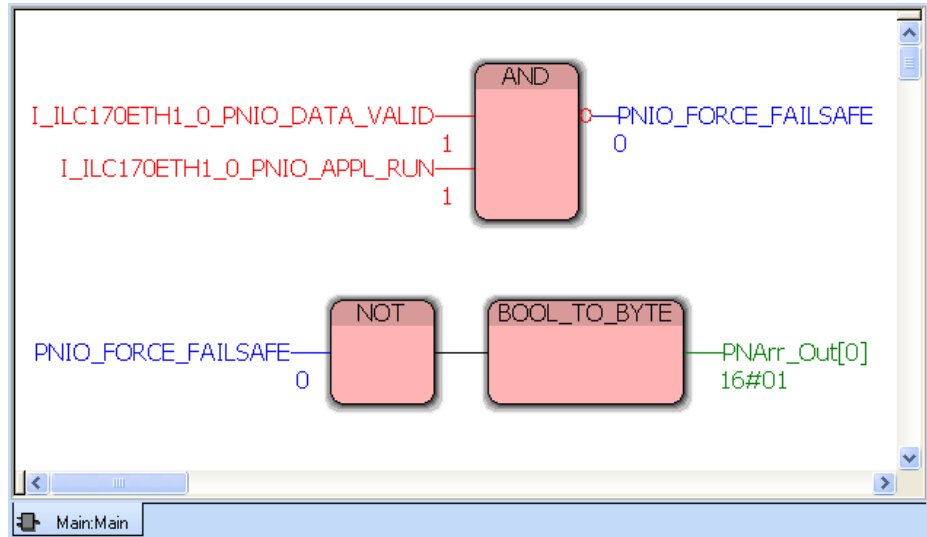

Figure 3-40 Program status

The `PNIO_FORCE_FAILSAFE` variable is in the FALSE state, thus communication is ensured and the outputs are set according to the process data.

If you remove the voltage connector of the ILC 170 2TX or change the device to the "Stop Mode", the status of `PNIO_FORCE_FAILSAFE` will change to TRUE. All outputs will be set to "0" and the value "1" is no longer transferred to the device.

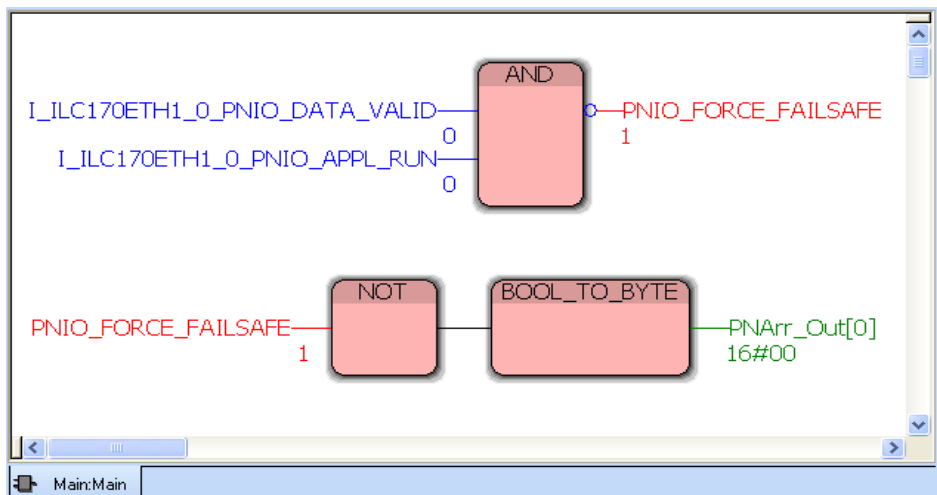

Figure 3-41 Program status in "Stop Mode"

Description of a typical application (all devices in one network)

3.4.6 Checking the program start of the lower-level project

The behavior described before can also be observed in the ILC170_Device project.

- Please open the lower-level project of the ILC 170 ETH 2TX.
- Then open the "Data_Acknowledge" POU and activate the Debug mode.

The following screen appears:

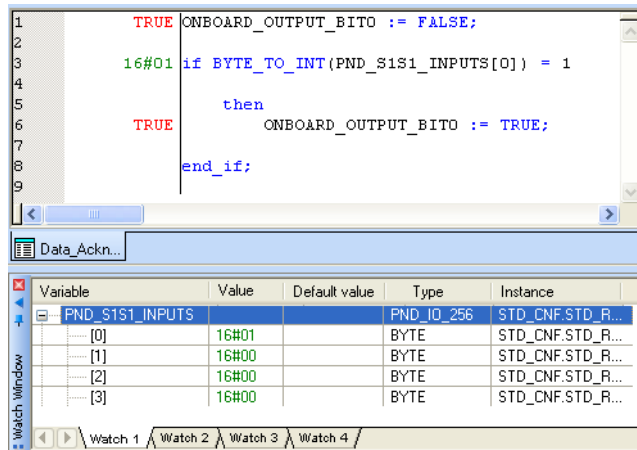

Figure 3-42 Program status active

The value 1 is in array [0] of the PND_S1S1_INPUTS. The ONBOARD_OUTPUT_BIT0 variable is TRUE and the LED is ON.

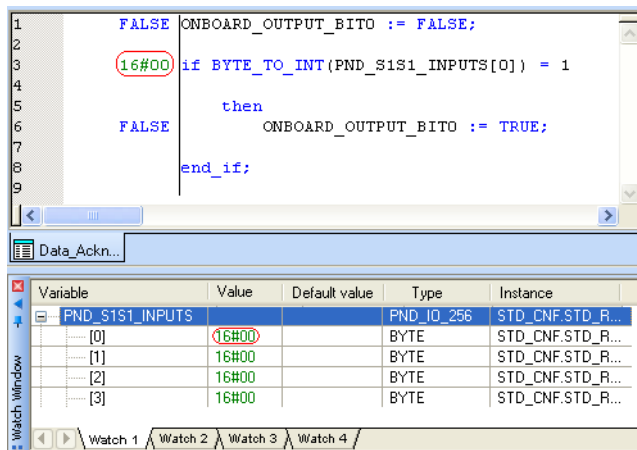

Figure 3-43 Program is stopped

When communication is interrupted by removing the voltage connector of the ILC 170 device or by changing into the "Stop Mode" through the ILC 330 PN, the value is set to "0".



If you need more detailed information, call the Diag+ diagnostic tool from PC WorX under View-> Diag+. Here you connect explicitly to a controller and receive further information.

UM EN PROFINET CTRL DEV

Description of a typical application (devices in several networks)

4 Description of a typical application (devices in several networks)

In the following application all devices are in several networks, see also the topology example on page 2-2.

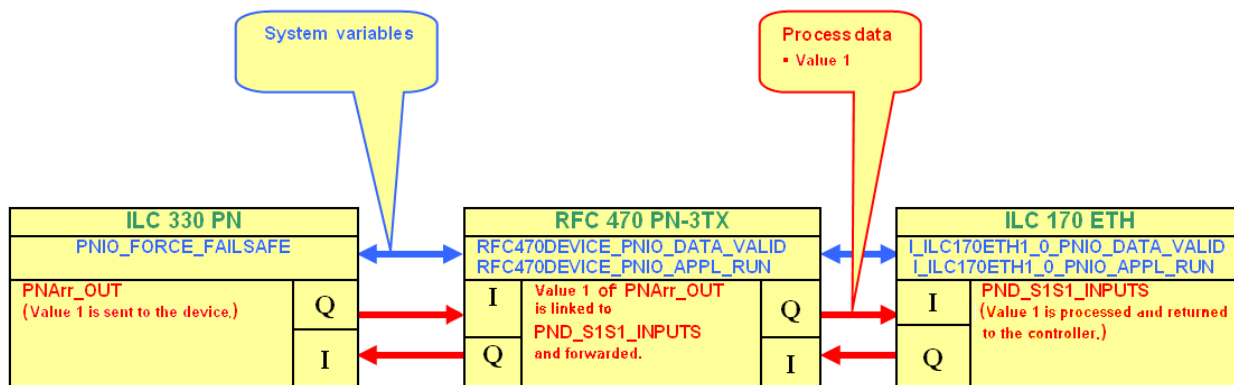

The following devices are used for this application:

| Device | Order No. | IP address |
|---------------------------------|-----------|--------------|
| ILC 330 PN as master | 2988191 | 192.168.1.3 |
| RFC 470 PN-3TX as master | 2916600 | 192.168.0.5 |
| RFC 470 PN-3TX as device | 2916600 | 192.168.1.5 |
| ILC 170 ETH 2TX as device | 2916532 | 192.168.0.7 |
| FL SWITCH SMCS 4TX (optional) | 2989093 | - |
| Laptop (higher-level network 1) | | 192.168.1.10 |
| Laptop (lower-level network 2) | | 192.168.0.10 |

UM EN PROFINET CTRL DEV

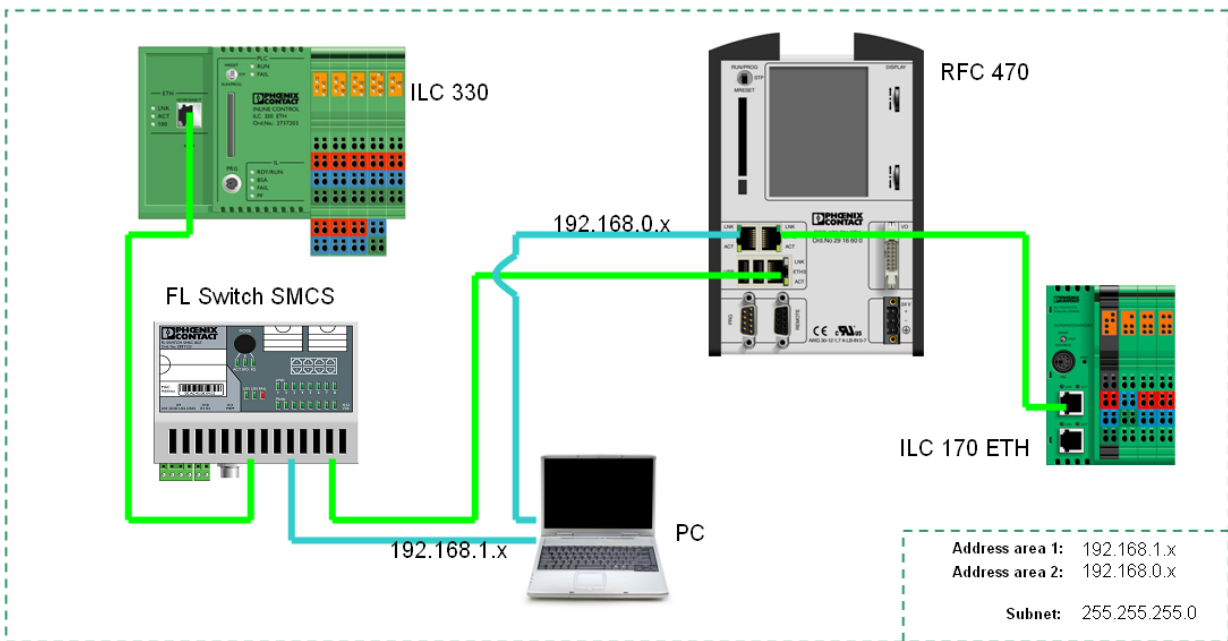

Figure 4-1 Typical application, devices in several networks

In this example, a project is created on the lower-level controller (ILC 170 ETH 2TX) by requesting the status variables of PROFINET communication (PND_S1S1). For this purpose, a function block is created in structured text that sets the value "true" on the ONBOARD_OUTPUT_BIT0 system variable. The LED is ON when the ILC 330 PN sends the value "1". This example uses two networks, the RFC 470 PN-3TX links the process data between ILC 330 PN and ILC 170 ETH 2TX. The program is identical with the first example application.

In the example, a function block is used for logical ANDing. The PNIO_DATA_VALID and PNIO_APPL_RUN variables (both system variables) of the RFC map the status of the inputs to which the PNIO_FORCE_FAILSAFE system variable is connected.

The PNIO_DATA_VALID system variable indicates for each PROFINET IO device whether the connection to this PROFINET IO device was established successfully. Only if this bit is set does the PROFINET IO device supply valid data and all other process values are active.

A negated result is linked to the PNIO_FORCE_FAILSAFE variable. The PROFINET system is stable when the system variable PNIO_FORCE_FAILSAFE = 0. All outputs are set according to the process data. If PNIO_FORCE_FAILSAFE = 1 (at least one PNIO_DATA_VALID variable set to 0), the safe state "0" is output for all PROFINET IO device outputs.

Assign the value 1 to the PNArr_OUT[0] variable (user variable). This is done via the negated status of the PNIO_FORCE_FAILSAFE system variable. The value 1 is converted in the BYTE data type, since the PROFINET process data (PND_IO_256) are assigned as ARRAY OF BYTE data type for the variable.

Description of a typical application (devices in several networks)

4.1 Offline configuration

4.1.1 Lower-level project

- Select the "New Project..." command from the "File" menu to create a new project using a template.

The tree structure and the selection of the control system are now prepared.

- Select the "ILC 170 ETH Rev. >01/3.50" control system and confirm your selection with "OK".

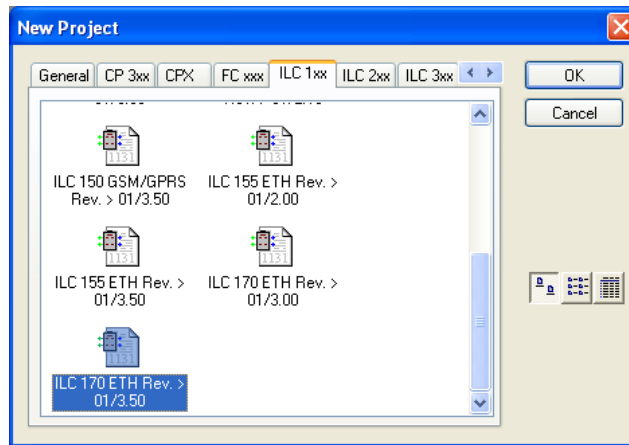

Figure 4-2 Selecting the controller

- Select the "File, Save Project As/Zip Project As..." command.
- Enter a project name (here: ILC170_Device) and save the project.

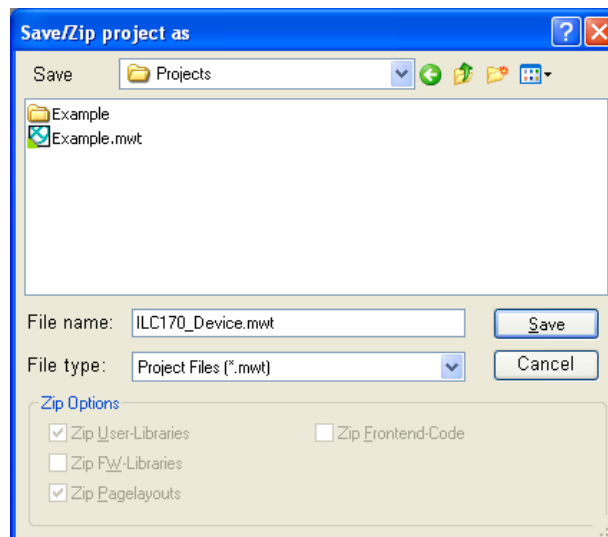

Figure 4-3 Save project

UM EN PROFINET CTRL DEV

The following window opens:

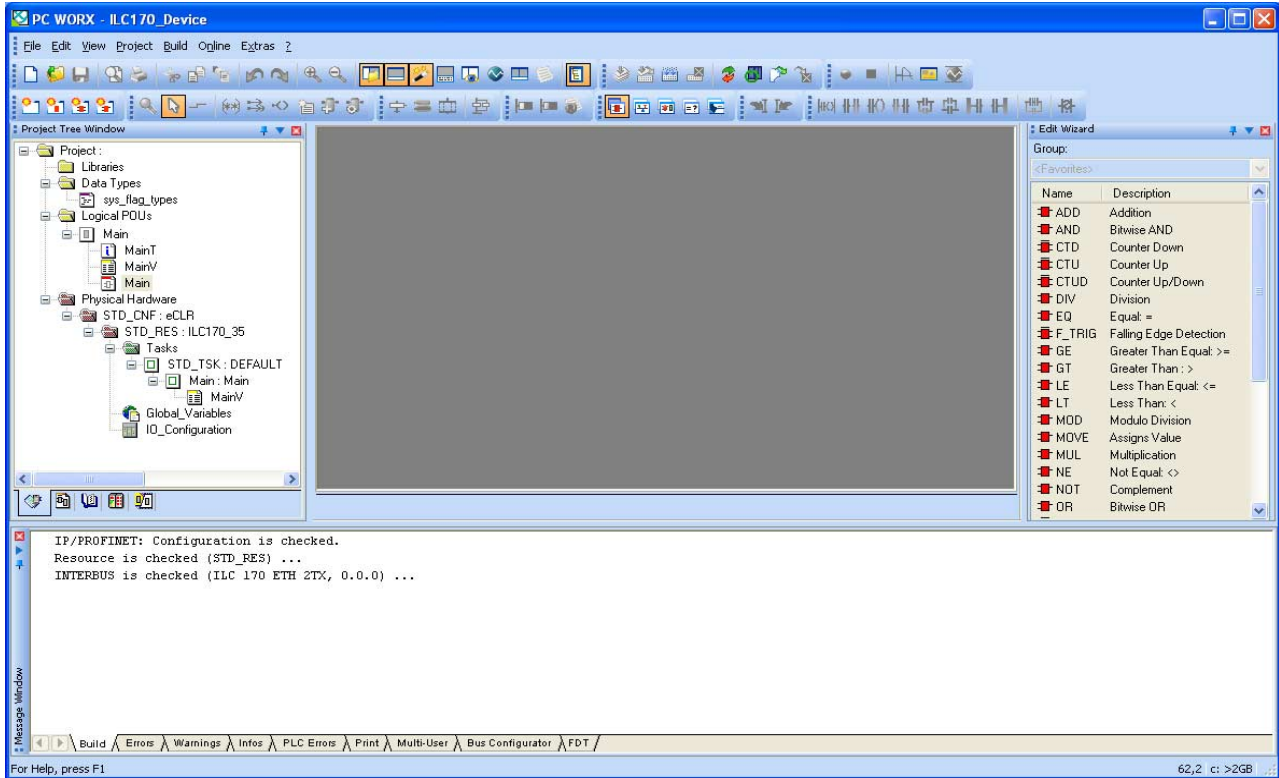

Figure 4-4 PC WorX start screen

- Right-click on Logical POU's.
- Insert the function block.

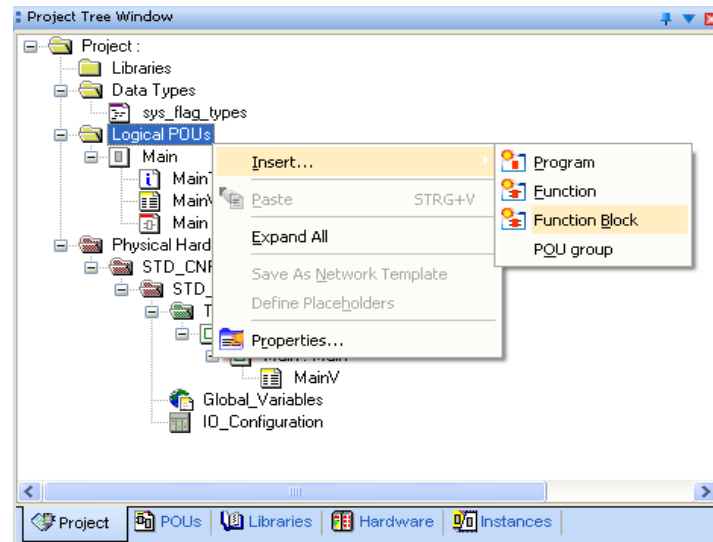

Figure 4-5 Inserting the function block

Description of a typical application (devices in several networks)

- Select the ST (Structured Text) language.
- Name the block "Data_Acknowledge".

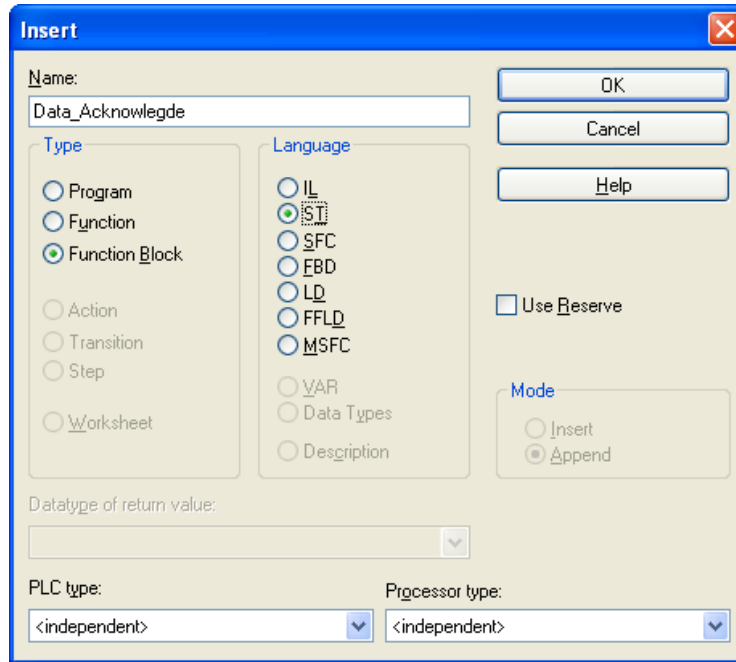

Figure 4-6 Selecting the programming language and naming the function block

- Open the worksheet by double-clicking on "Data_Acknowledge".

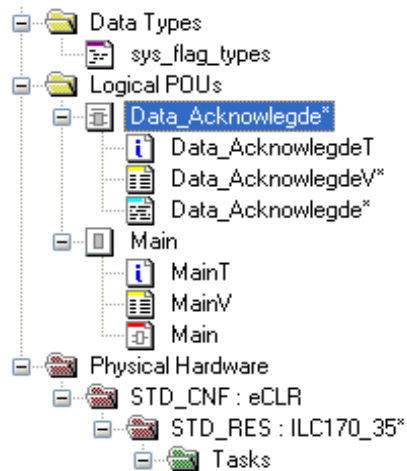

Figure 4-7 Opening the worksheet

UM EN PROFINET CTRL DEV

- Insert the following program to your worksheet.

```

1  ONBOARD_OUTPUT_BIT0 := FALSE;
2
3  if
4      BYTE_TO_INT(PND_S1S1_INPUTS[0]) = 1
5
6      then
7          ONBOARD_OUTPUT_BIT0 := TRUE;
8
9  end_if;
10

```

Figure 4-8 Inserting the program

The ONBOARD-OUTPUT_BIT0 system variable and the PROFINET IO device status variable PND_S1S1_INPUTS for the process data can be found under the **Global_Variables**.

- Select the process data length of 256 bytes (PND_IO_256) for the data exchange between master and device.

| Name | Typ | Verwendung | Beschreibung |
|--------------------------|------------|------------|---|
| ONBOARD_INPUT_BIT2 | BOOL | VAR_GLOBAL | Local input IN3 |
| ONBOARD_INPUT_BIT3 | BOOL | VAR_GLOBAL | Local input IN4 |
| ONBOARD_INPUT_BIT4 | BOOL | VAR_GLOBAL | Local input IN5 |
| ONBOARD_INPUT_BIT5 | BOOL | VAR_GLOBAL | Local input IN6 |
| ONBOARD_INPUT_BIT6 | BOOL | VAR_GLOBAL | Local input IN7 |
| ONBOARD_INPUT_BIT7 | BOOL | VAR_GLOBAL | Local input IN8 |
| ONBOARD_OUTPUT_BIT0 | BOOL | VAR_GLOBAL | Local output OUT1 |
| ONBOARD_OUTPUT_BIT1 | BOOL | VAR_GLOBAL | Local output OUT2 |
| ONBOARD_OUTPUT_BIT2 | BOOL | VAR_GLOBAL | Local output OUT3 |
| RTC_DAY | INT | VAR_GLOBAL | System time (day) |
| RTC_YEAR | INT | VAR_GLOBAL | System time (year) |
| PND_S1S1_PLC_RUN | BOOL | VAR_GLOBAL | Status of the higher-level control system |
| PND_S1S1_VALID_DATA... | BOOL | VAR_GLOBAL | IO Controller has established the connection |
| PND_S1S1_OUTPUT_STAT... | BOOL | VAR_GLOBAL | IOP status of the higher-level control system |
| PND_S1S1_INPUT_STATUS... | BOOL | VAR_GLOBAL | IOC status of the higher-level control system |
| PND_S1S1_DATA_LENGTH | WORD | VAR_GLOBAL | Process data length |
| PND_S1S1_OUTPUTS | PND_IO_256 | VAR_GLOBAL | Output process data |
| PND_S1S1_INPUTS | PND_IO_256 | VAR_GLOBAL | Input process data |
| IB_DEVICE_PARAM_ACTIV... | BOOL | VAR_GLOBAL | Interbus device configuration activated |
| IB_DEVICE_PARAM_READY | BOOL | VAR_GLOBAL | Interbus device configuration completed |
| IB_DEVICE_PARAM_ERROR | BOOL | VAR_GLOBAL | Interbus device configuration error |

Figure 4-9 Selecting the process data

Description of a typical application (devices in several networks)

- Afterwards insert the created function block in the "Main" worksheet using drag & drop.

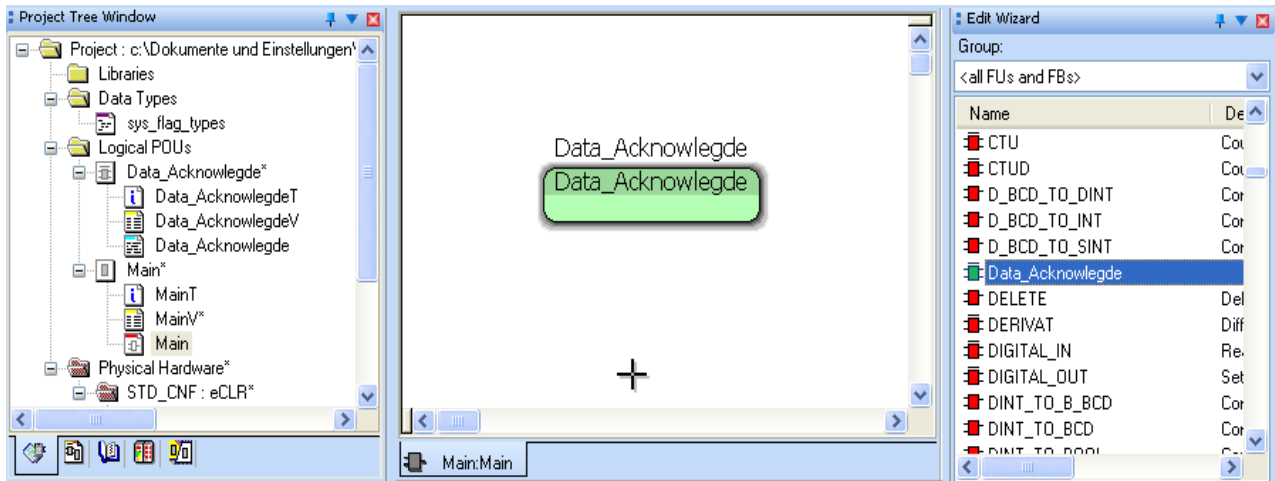

Figure 4-10 Inserting the function block into the worksheet

- Compile the project and save it.
- Close the project.

UM EN PROFINET CTRL DEV

4.1.2 RFC 470 PN-3TX higher-level/lower-level project

- Select the "New Project..." command from the "File" menu to create a new project using a template.

The tree structure and the selection of the control system are now prepared.

- Select the "RFC 470 PN-3TX Rev. > 00/4.6F/3.50" control system and confirm your selection with "OK".

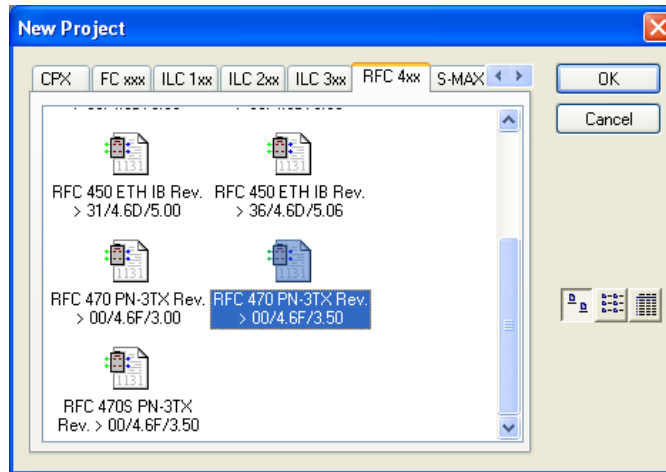

Figure 4-11 Selecting the controller

- Select the "File, Save Project As/Zip Project As..." command.
- Enter a project name (**here: RFC470_Controller_Device**) and save the project.

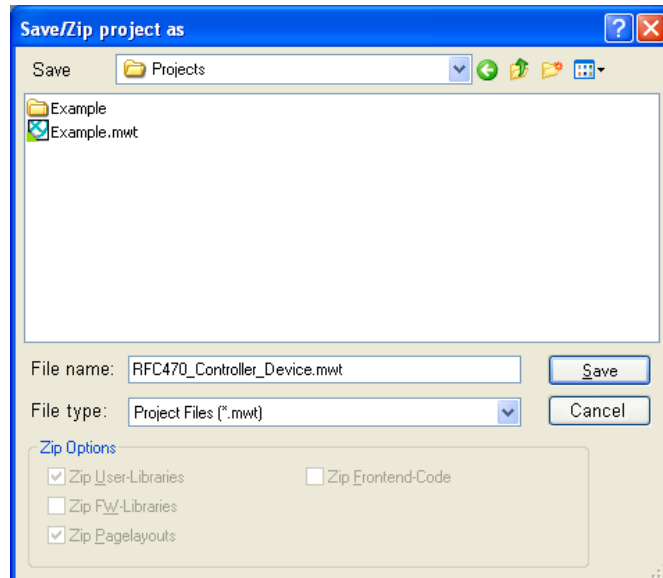

Figure 4-12 Save project

Description of a typical application (devices in several networks)

The following window opens:

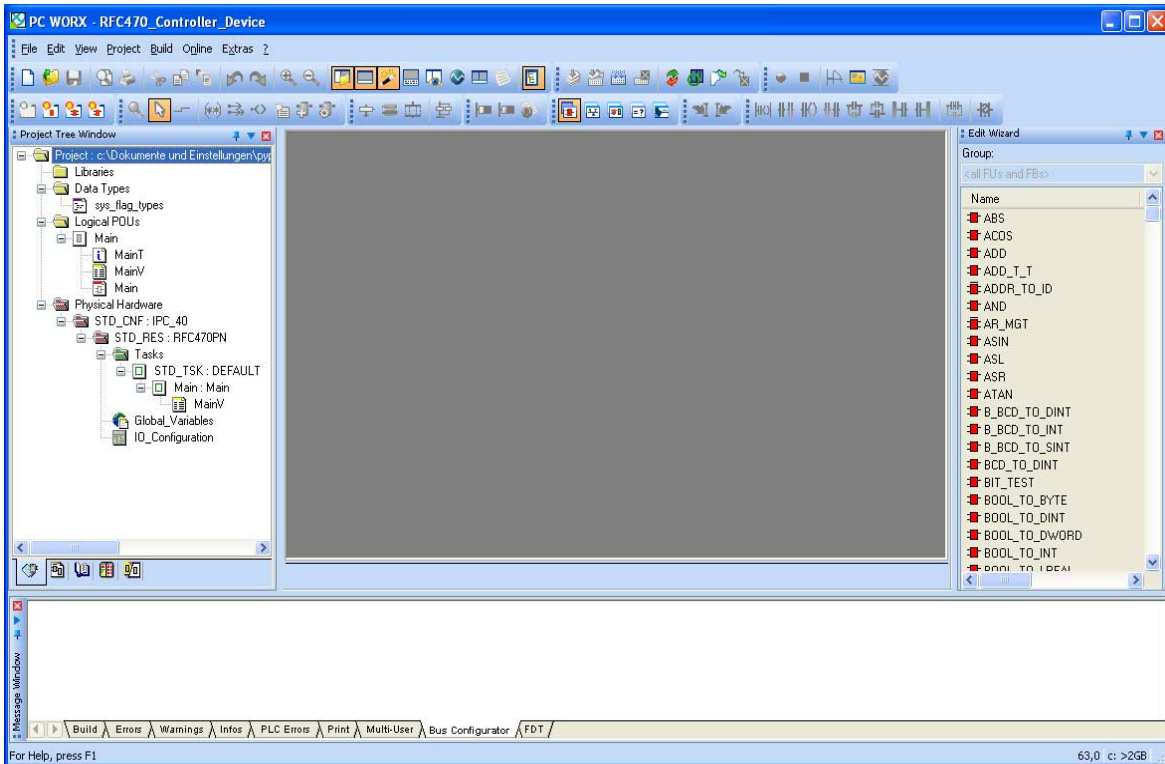

Figure 4-13 PC WorX start screen

- Right-click on Logical POU's.
- Insert the function block.

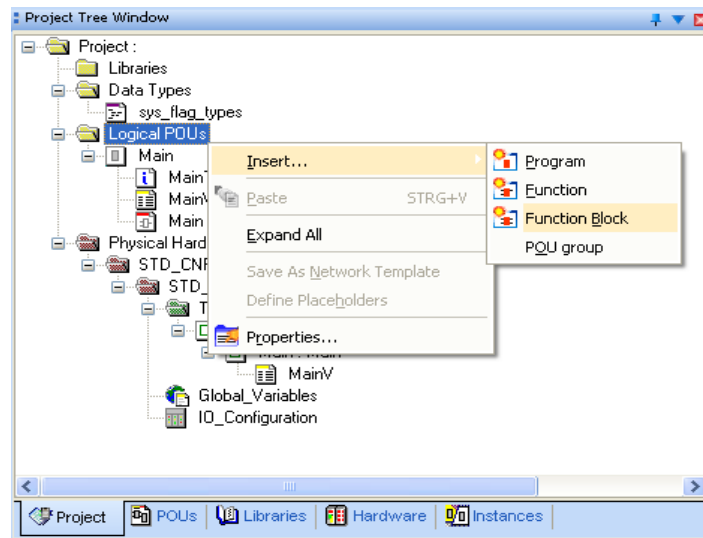

Figure 4-14 Inserting the function block

UM EN PROFINET CTRL DEV

- Select the ST (Structured Text) language.
- Name the block "Data_Acknowledge".

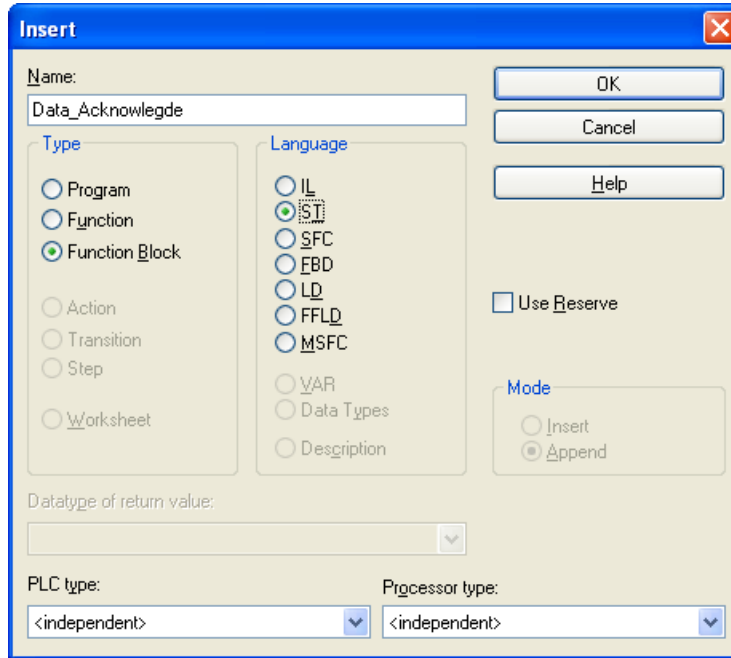

Figure 4-15 Selecting the programming language and naming the function block

- Open the worksheet by double-clicking on "Data_Acknowledge".

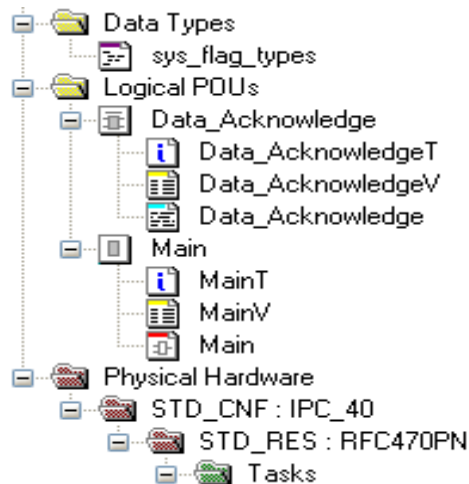
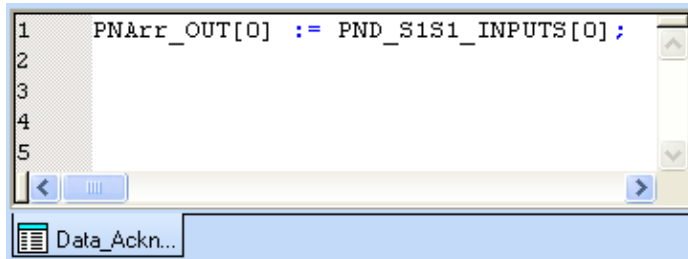

Figure 4-16 Opening the worksheet

Description of a typical application (devices in several networks)

- Insert the following program to your worksheet.



```

1  PN&arr_OUT[0] := PND_S1S1_INPUTS[0];
2
3
4
5

```

Figure 4-17 Inserting the program

The PN&arr_OUT[0] variable is linked with the PROFINET device status variable PND_S1S1_INPUTS, so that the ILC 170 device can call the status of the ONBOARD_OTPOT_BIT0 system variable.

Select the maximum process data length of 256 bytes (PND_IO_256) for the data exchange between ILC 330 PN, RFC 470 PN-3TX and ILC 170 ETH 2TX.

The RFC 470 PN-3TX can transmit up to 512 bytes of data, however, the process data length is adapted to the ILC 170 ETH 2TX. It can transmit up to 256 bytes.

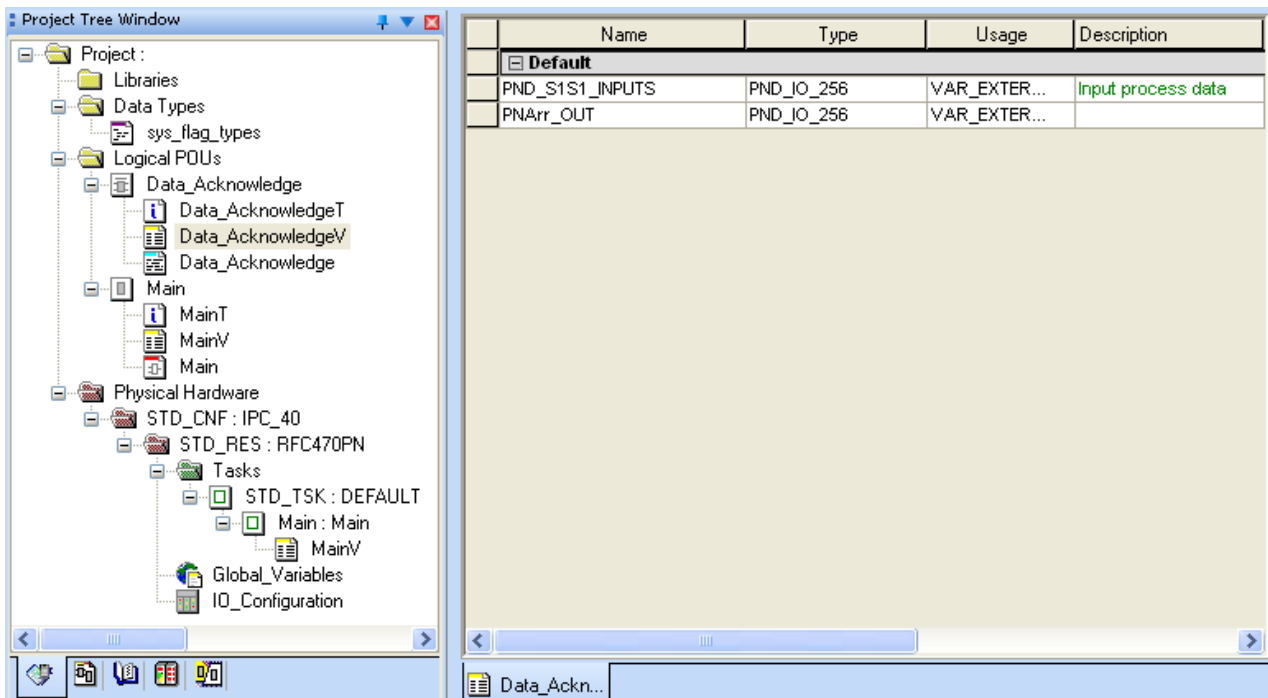

| Name | Type | Usage | Description |
|-----------------|------------|--------------|--------------------|
| Default | | | |
| PND_S1S1_INPUTS | PND_IO_256 | VAR_EXTER... | Input process data |
| PN&arr_OUT | PND_IO_256 | VAR_EXTER... | |

Figure 4-18 Creating the variables

UM EN PROFINET CTRL DEV

- Afterwards insert the created function block in the "Main" worksheet using drag & drop.

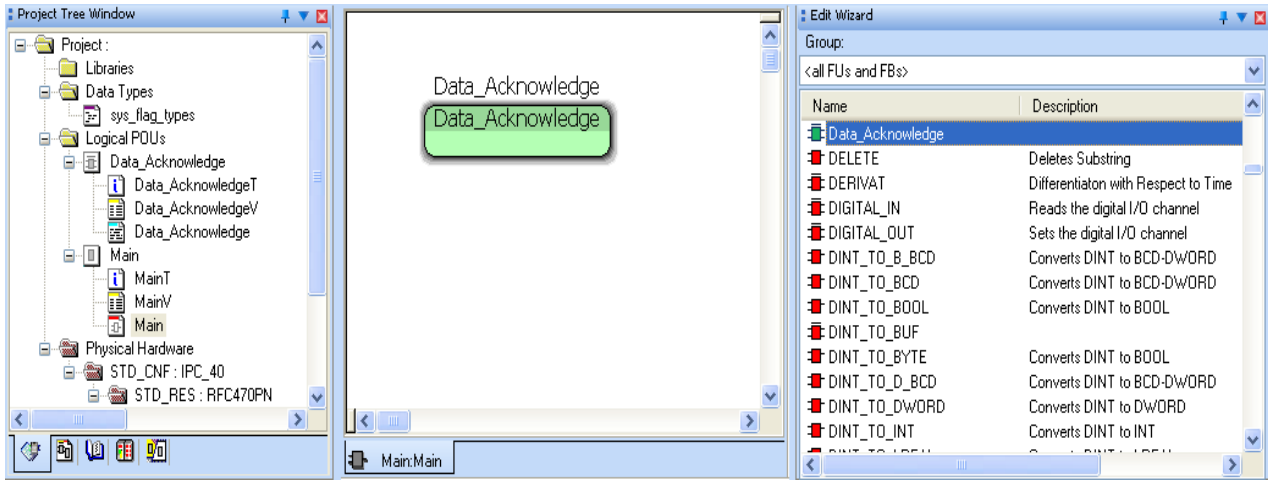

Figure 4-19 Inserting the function block into the worksheet

- Compile the project and save it.

Description of a typical application (devices in several networks)

Assigning process data

- Switch to the process data assignment workspace.
- In the top left window, "Symbols/Variables", select the "System Variables" program.
- Highlight the PROFINET IO device in the top right window.
- Highlight the I256 process data item in the bottom right window.
- Highlight the PNArr_OUT variable in the bottom left window.
- Enable the context menu on the variable and select the "Connect" command.

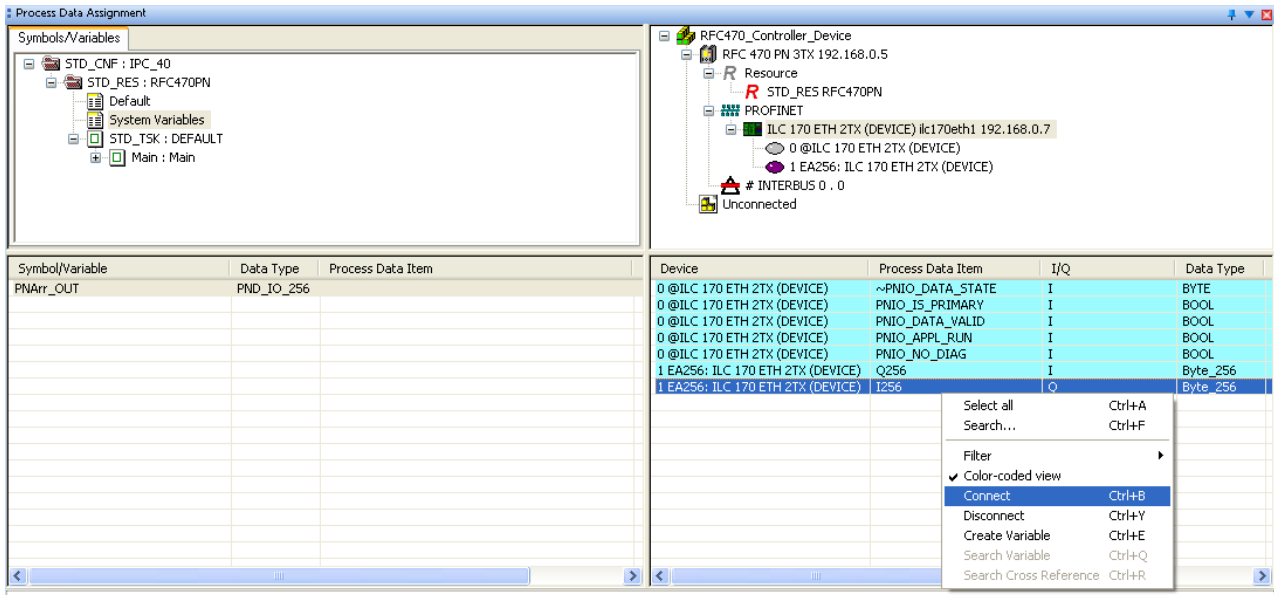

Figure 4-20 Linking process data

- Compile, save, and close the project.

4.1.3 Higher-level project

- Select the "New Project..." command from the "File" menu to create a new project using a template.

The tree structure and the selection of the control system are now prepared.

- Select the "ILC 330 PN Rev. > 01/4.6F/3.50" control system and confirm your selection with "OK".

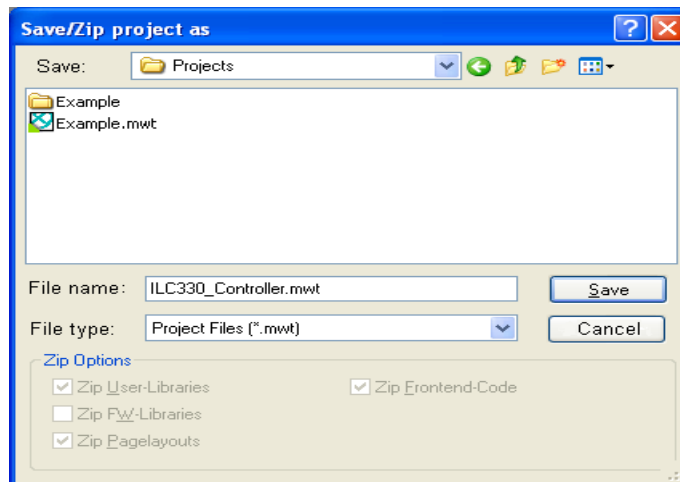

Figure 4-21 Selecting the controller

- Select the "File, Save Project As/Zip Project As..." command.
- Enter a project name (**here: ILC330_Controller** and save the project.

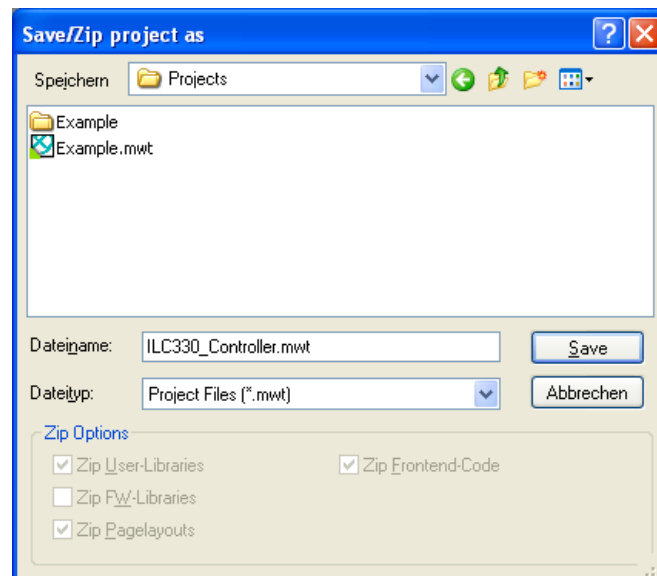

Figure 4-22 Save project

Description of a typical application (devices in several networks)

The following window opens:

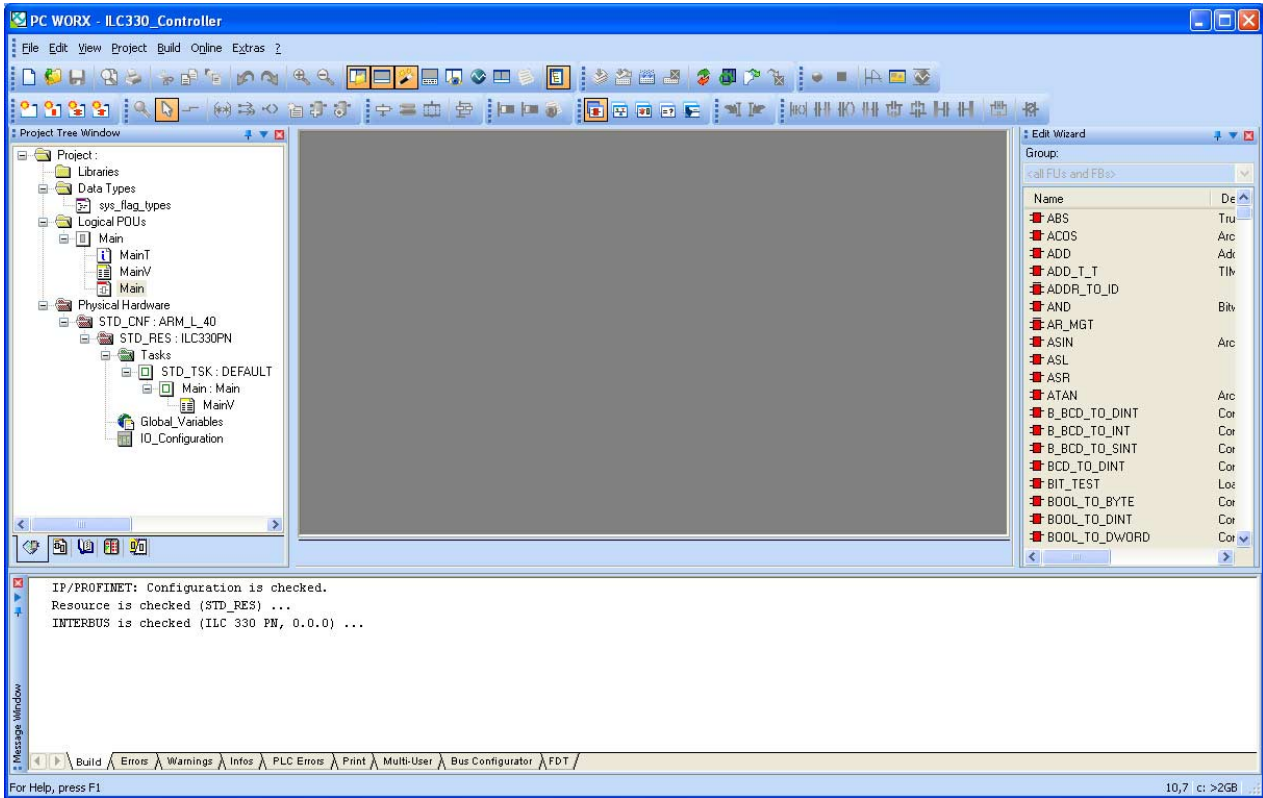



Figure 4-23 Start screen

UM EN PROFINET CTRL DEV

Integrating the RFC 470 PN-3TX as PROFINET IO device

The following section describes how you integrate the RFC 470 PN-3TX as PROFINET device in the "ILC330_Controller" project.

- Change to the bus structure. To do this, click on the "Bus Structure" icon in the toolbar. 
- Insert the RFC 470 PN-3TX as a device into the bus structure (right click).

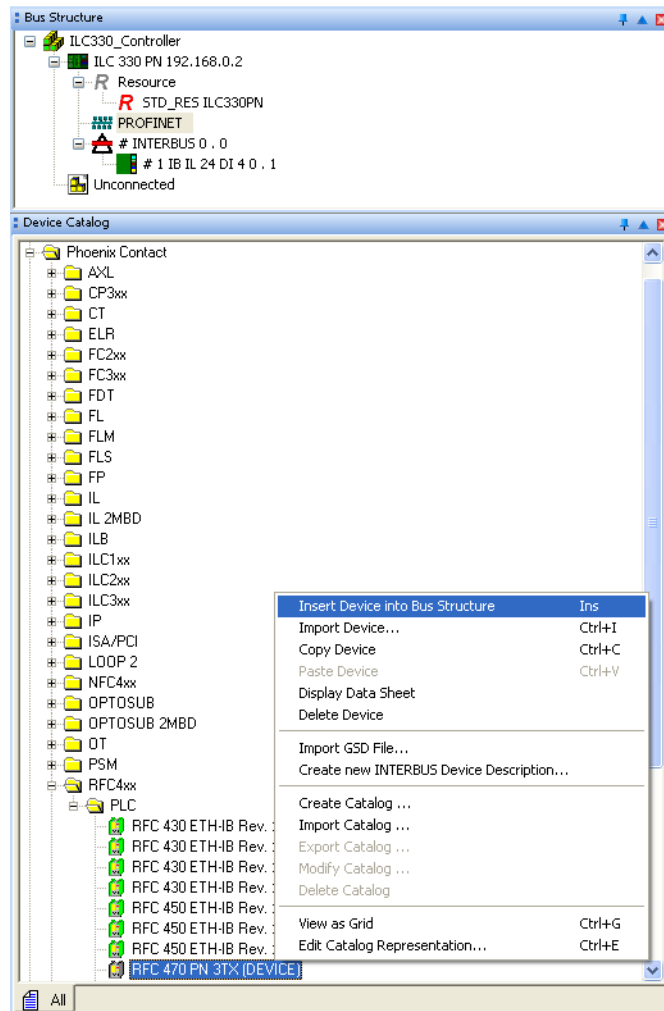

Figure 4-24 Insert the RFC 470 PN-3TX as a device into the bus structure

Description of a typical application (devices in several networks)

The PROFINET device inserted will be displayed in the Bus Structure workspace. The IP address is created depending on the IO controller address.

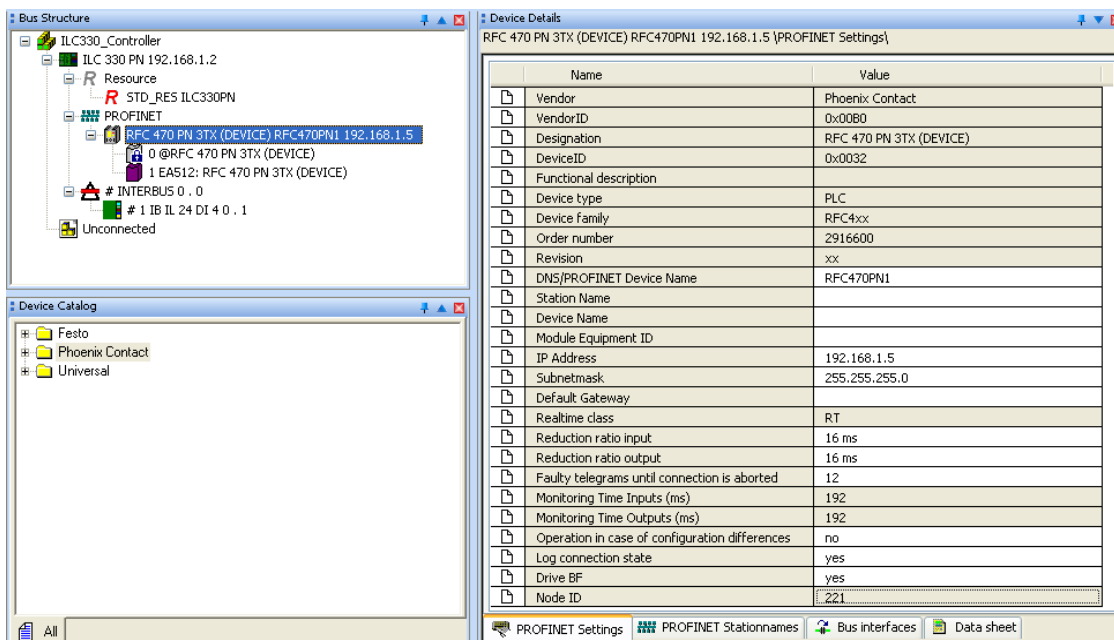

Figure 4-25 The RFC 470 PN-3TX integrated as a PROFINET IO device in the bus structure

The process data of the PROFINET device will be displayed in the Device Details workspace of the "Process Data" tab.

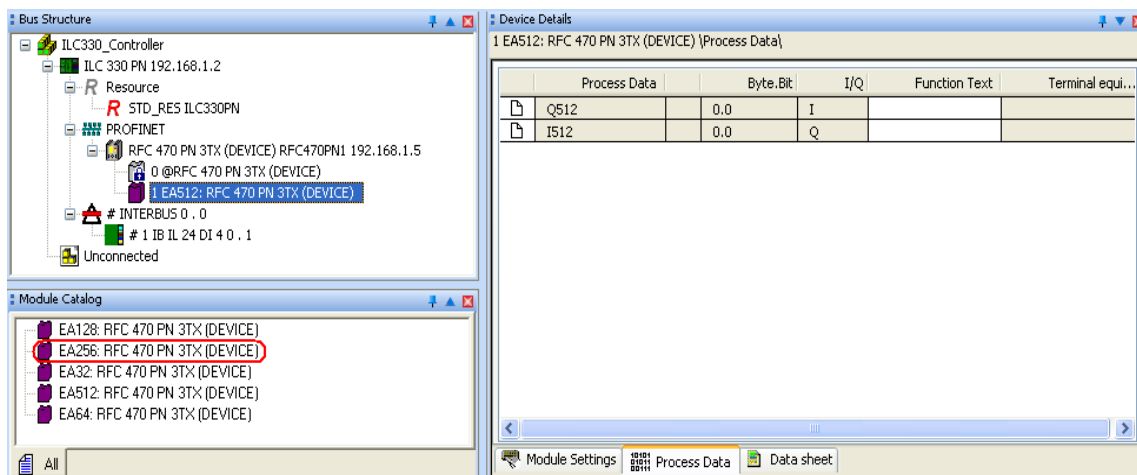



Figure 4-26 Process data of the PROFINET IO device

- Replace the EA512 I/O module with the EA256 I/O module of the RFC. As a device the lower-level ILC 170 ETH 2TX can transmit up to 256 bytes.
- Delete the EA512 I/O module (right click).
- Drag the EA256 I/O module in the bus structure (left click).

The RFC 470 PN-3TX is now available as PROFINET IO device in the "ILC330_Controller" PC WorX project.

UM EN PROFINET CTRL DEV

- Switch to the IEC programming  and open the "Main" worksheet.
- Add the mapped function blocks.
- Create the following variables at the links as specified.
- Negate the output at the AND block.

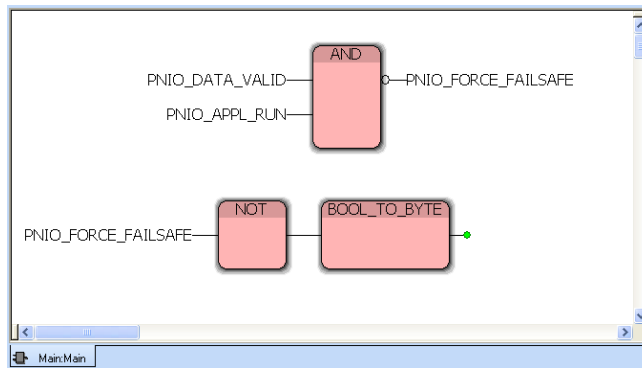

Figure 4-27 Adding function blocks

- Save the modified main program.

Description of a typical application (devices in several networks)

Assigning process data

For the system variables for displaying the status of a PROFINET IO device, the process data is generated automatically.

- Switch to the process data assignment workspace.
- In the top left window, "Symbols/Variables", select the program (here: Main : Main).
- Highlight the PROFINET IO device in the top right window.
- Highlight the PNIO_DATA_VALID variable in the bottom right window.
- Highlight the PNIO_DATA_VALID variable in the bottom left window.
- Enable the context menu on the variable and select the "Connect" command.
- Proceed in the same way for the PNIO_APPL_RUN variable.

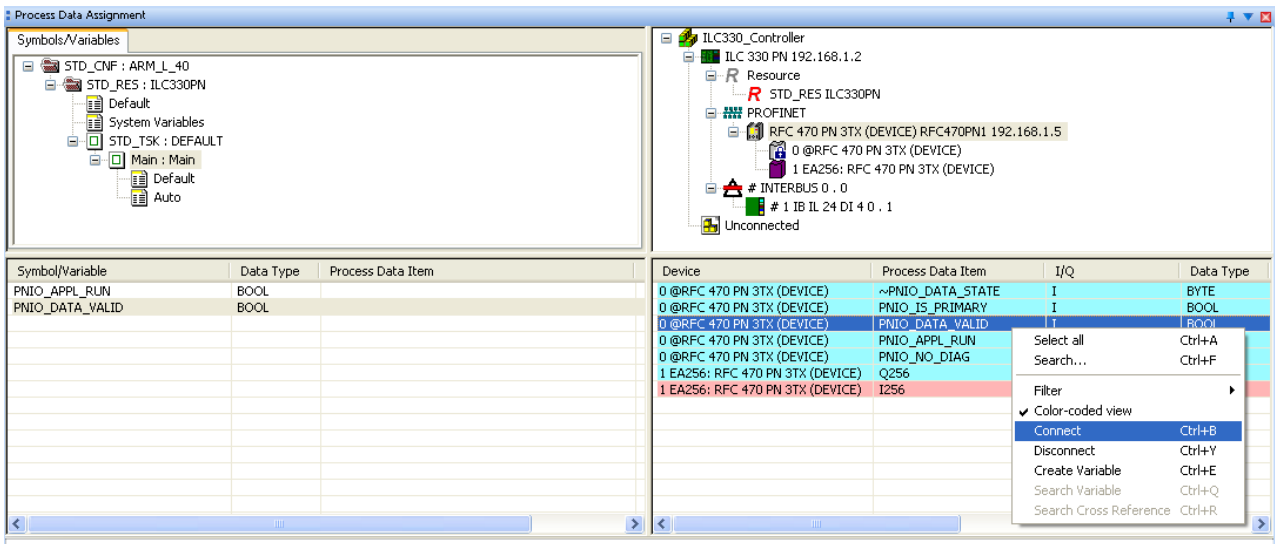

Figure 4-28 Linking variables

- In addition, create the "PNArr_Out" variable with the "PND_IO_256" data type as "VAR-EXTERNAL".

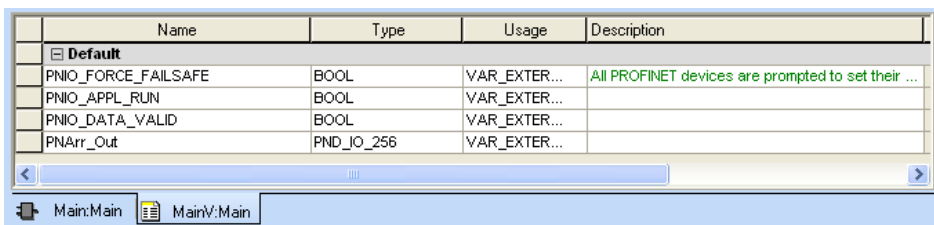

Figure 4-29 Creating the "PNArr_Out" variable

UM EN PROFINET CTRL DEV

- Connect the "PNArr_Out" variable to the "I256" process data item of the RFC 470 PN-3TX device.

The total available data width of 256 bytes was selected in this example. You can change it later in the online configuration.

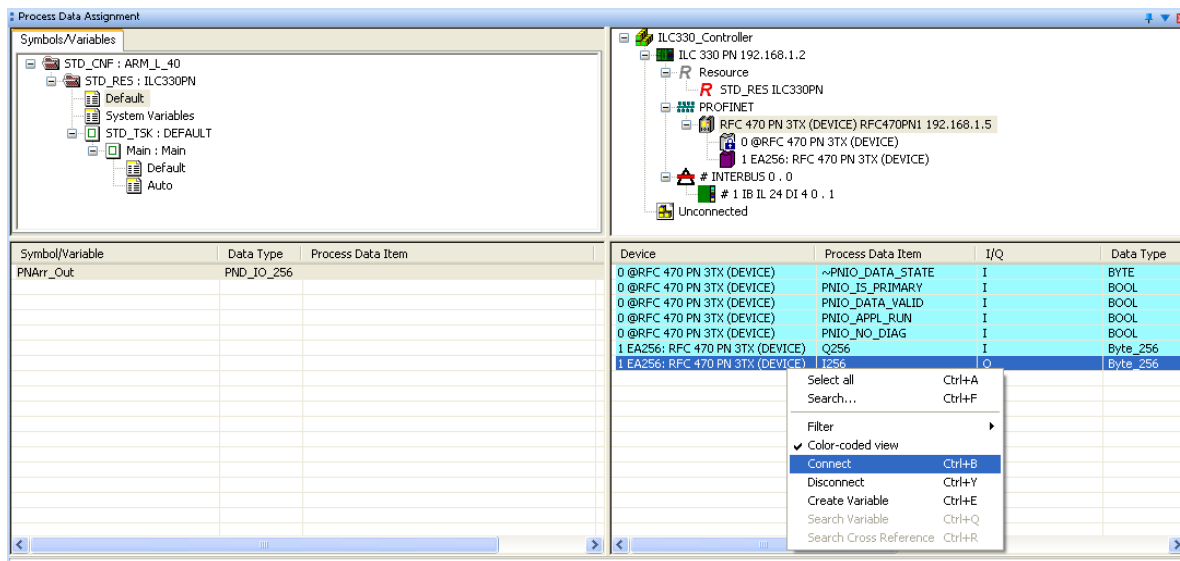

Figure 4-30 Connecting the "PNArr_Out" variable to the process data

- Switch to IEC programming and link the variables as shown in the figure below.

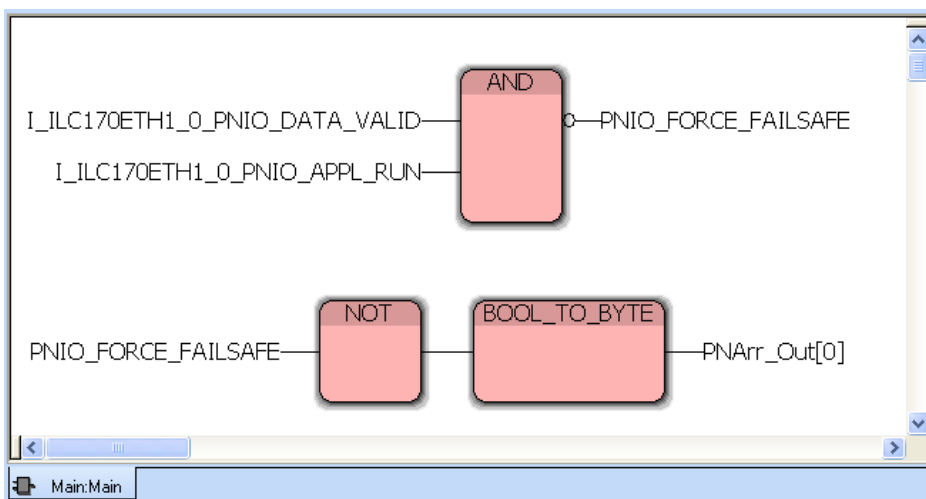

Figure 4-31 Inserting and linking variables

- Select the "0" array in the byte array by writing the field "[0]" after the "PNArr_Out" variable.
- Then compile the project and save it.

Description of a typical application (devices in several networks)

4.2 Online configuration

4.2.1 Preparing the PC for communication

- For configuration and parameterization assign an appropriate IP address for your PC within the 192.168.0.x address area. In this example the PC receives the address 192.168.0.10.

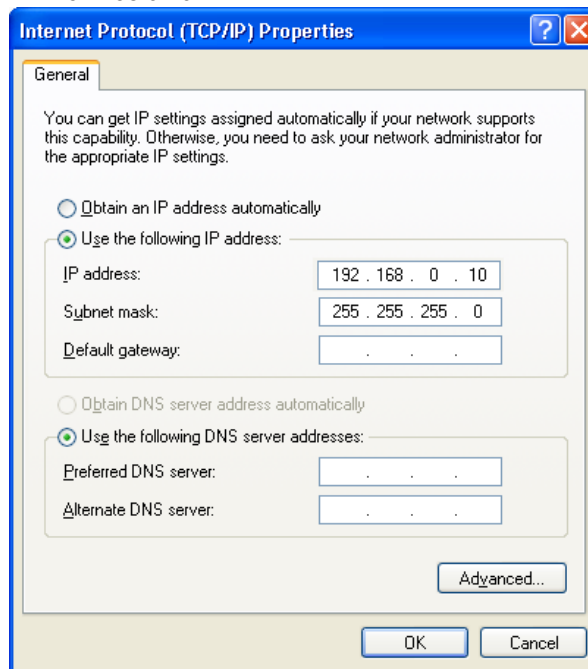

Figure 4-32 Assigning an IP address

- Select the network card of your PC that is to be used for communication in the "Tools/PROFINET..." menu of PC WorX.

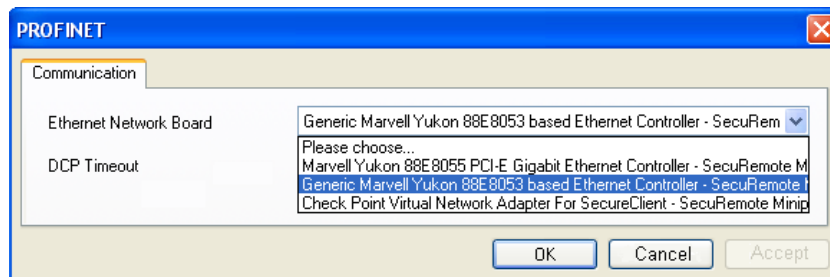

Figure 4-33 Selecting the network card

Now the PC is ready for communications within the subnet.



Set the address 192.168.1.10 for the higher-level network with the ILC 330 PN as a master and the RFC 470 PN-3TX as a device. Set the address 192.168.0.10 for the lower-level network with the RFC 470 PN-3TX as a master and the ILC 170 ETH 2TX as a device.

4.2.2 Configuring the ILC 170 ETH 2TX

Assigning IP settings

To set the IP address in PC WorX proceed as described below:

- Open your project "ILC170_Device".
- Establish an Ethernet connection between your PC and the controller.
- In the PC WorX menu bar, select the "Extras... BootP/SNMP/TFTP-Configuration..." menu.

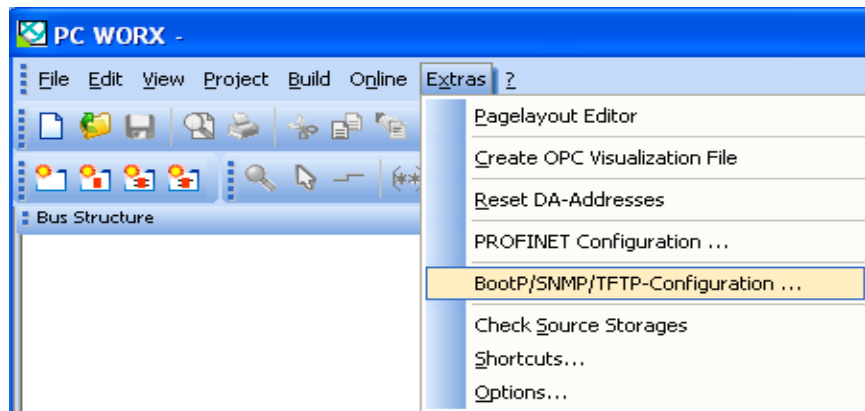

Figure 4-34 Selecting "Extras/BootP/SNMP/TFTP-Configuration..."

- Activate the "BootP server active" checkbox.

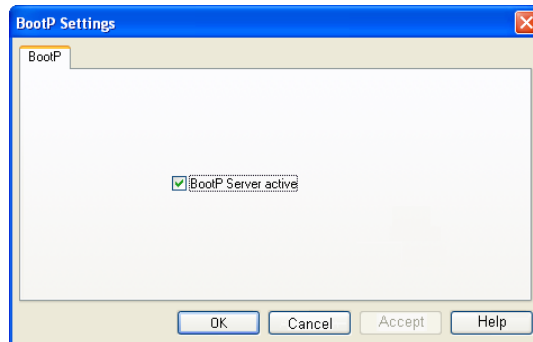

Figure 4-35 Activate BootP server

- Switch to the bus configuration workspace, see Figure 4-37
- Select the controller node.
- Select the "IP Settings" tab in the "Device Details" window.
- Enter the MAC address of the controller. It is printed on the device and starts with 00.A0.45.

Description of a typical application (devices in several networks)

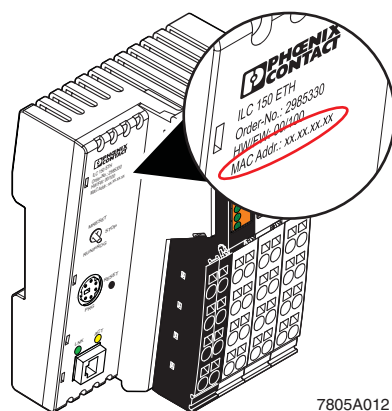

Figure 4-36 Printed MAC address on the ILC 150 ETH controller

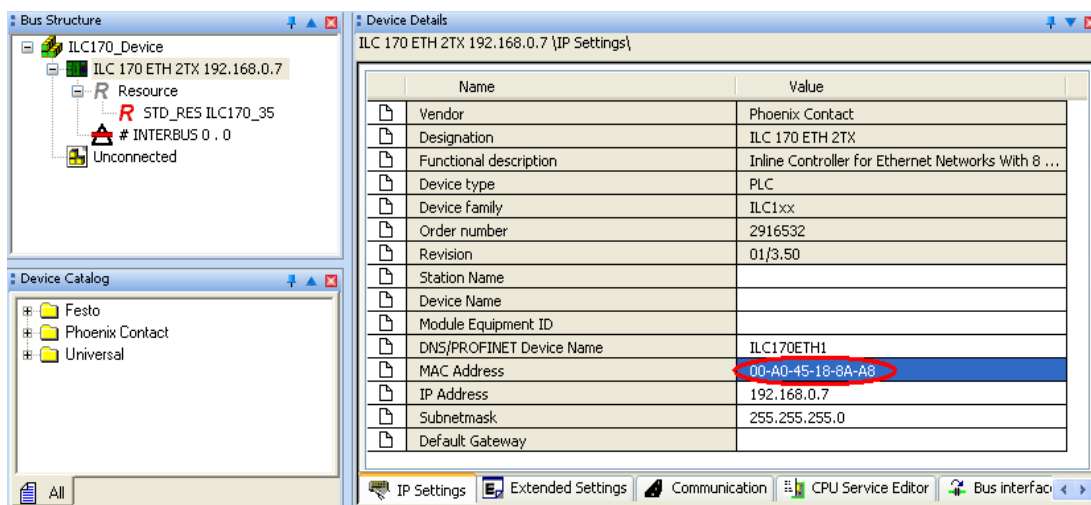

Figure 4-37 Entering the IP address

- Perform a cold restart for the controller.
- To do this, switch the supply voltage off and then on again after around 2 seconds.

The controller is assigned the IP address, which is specified in the project for the controller (here: 192.168.0.7). The following message appears in the message window in the "Bus Configurator" tab.

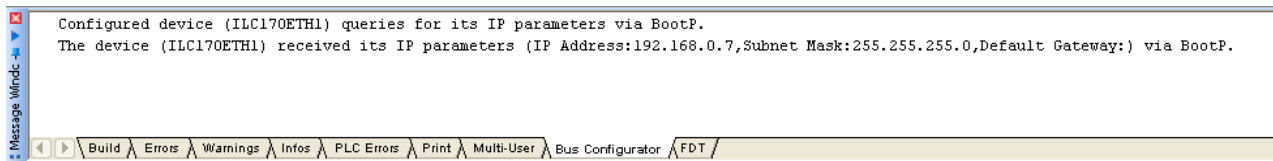

Figure 4-38 Message window

The IP address will now be permanently stored on the controller Flash memory.

4.2.3 Configuring the RFC 470 PN-3TX

By default upon delivery the diagnostic display has the following status:

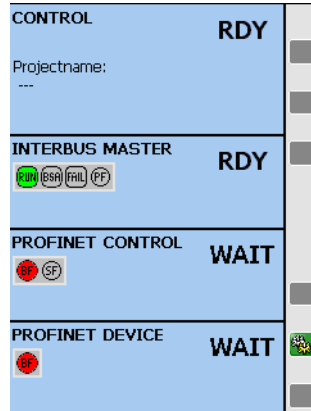

Figure 4-39 Diagnostic display

The initial assignment of the IP settings can generally always be carried out using the diagnostic display.

When using the PC WorX software, the initial assignment of the IP settings can be carried out with BootP or using the COM1 serial interface.

- If the Remote Field Controller already has IP settings that are valid in your network, you can modify the IP settings via the network using PC WorX.
- Set the RFC 470 PN-3TX to the mapped IP address 192.168.0.5. It can be accessed in the network after a restart of the device.

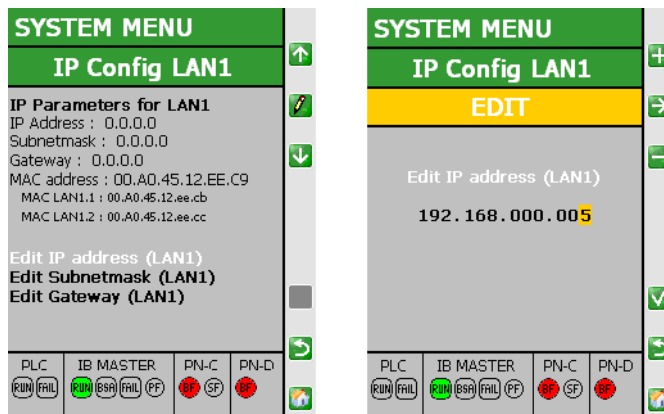

Figure 4-40 LAN1 configuration display

The procedure for assigning the IP settings is essentially the same for the LAN1 (LAN1.1/LAN1.2) and LAN 2 interfaces. The following describes the assignment of the IP settings at the LAN1 interface as an example. The LAN1.1/LAN1.2 interfaces are switched internally. Thus, both ports can be accessed using the IP settings defined.

Description of a typical application (devices in several networks)

For the LAN2 interface proceed as in the previous example, however, set the IP address to 192.168.1.5. The RFC 470 PN-3TX communicates with this address as a device.



NOTE:

The IP address of your PC must be in the same subnet as the LAN1 or LAN2 interface of the RFC 470 PN-3TX. Only then is communication for configuration of the ILC 170 ETH 2TX possible.

In this case the modification was done via the LAN1 interface (192.168.0.x subnet).

4.2.4 Configuring the ILC 330 PN

Assigning IP settings

- When assigning the IP settings for the ILC 330 PN, please proceed in the same way as for the ILC 170 ETH 2TX, see "Configuring the ILC 170 ETH 2TX" on page 4-22.
- Open the "ILC330_Controller" project.

Please not the following modifications:

Connect the network cable of your PC to the switch. Now you have established a connection from the PC to the ILC 330 PN.

- BootP server is active
- Enter the MAC address of the ILC 330 PN controller.
- Assign the IP address 192.168.1.2.

Switching on the IO PROFINET device function



The following applies to the devices:
ILC 170/330/350/370/390 PN / RFC 470 PN-3TX

By default upon delivery the PROFINET device function is switched off for every controller. To switch it on, start your existing project (in the example here: "ILC170_Device") in PC WorX and activate the PROFINET device function as follows:

- Switch to the "Extended Settings" tab.
- Select the "IO device status" item in the device details under "Network Settings".
- Under "Settings", select "activated" in the pull-down menu.

UM EN PROFINET CTRL DEV

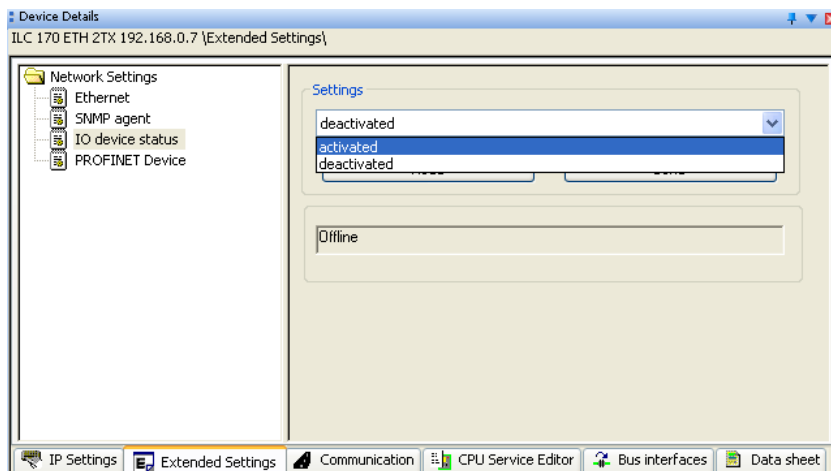

Figure 4-41 Device function activated

- Click on "Transmit".
- In the "Settings Communication Path" dialog confirm with "OK" the suggested IP address or the one you have selected for your application.

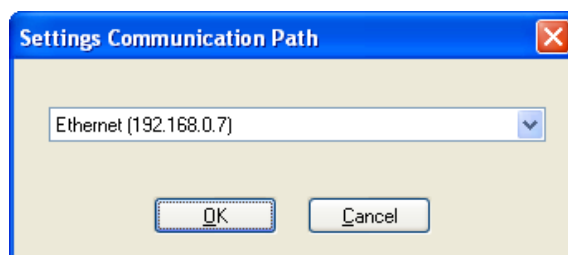

Figure 4-42 Setting the communication path

Successful execution of the service will be displayed in the status window.

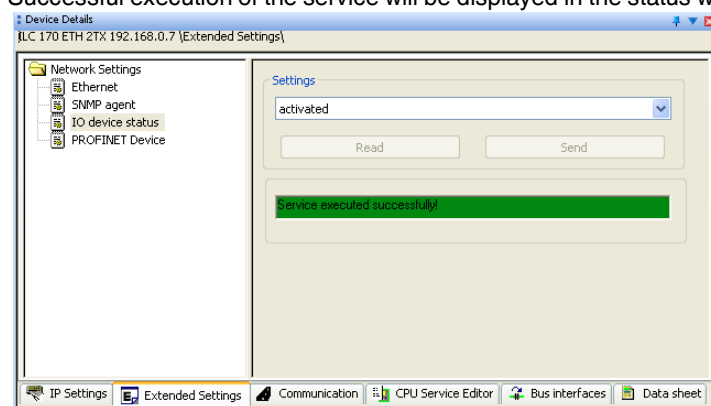

Figure 4-43 Status window

To transfer the network settings you have to reset the IO controller.

Description of a typical application (devices in several networks)

- Select the "Ethernet" item in the Device Details window under "Network Settings".



The device name in the higher-level project (ILC 170 ETH device) must match the device name of the lower-level project (ILC 170 ETH).

- In the "Activate Network Settings" area click the "Reset Control System" button.

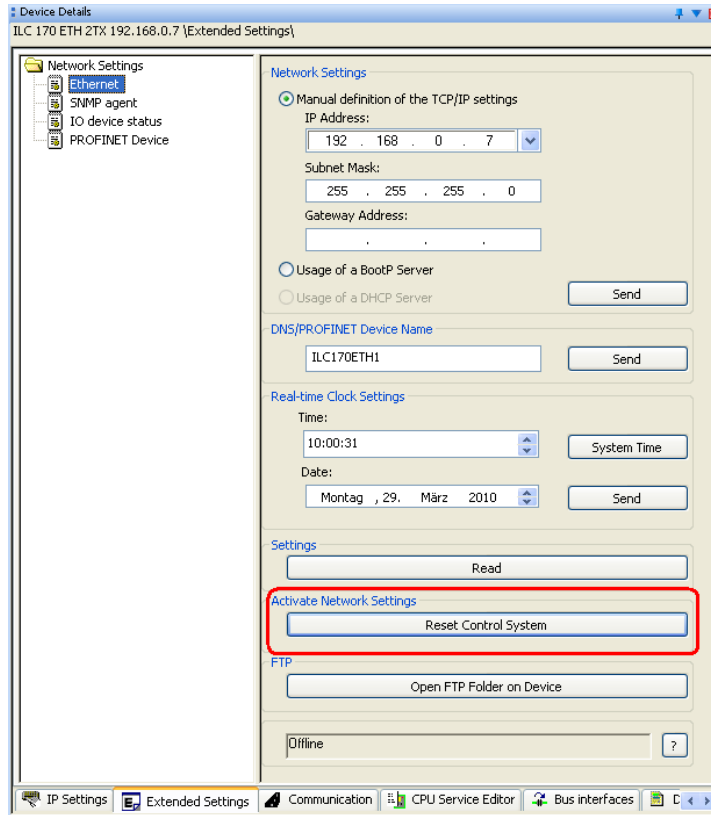

Figure 4-44 Resetting the controller

- In the "Settings Communication Path" dialog confirm with "OK" the suggested IP address or the one you have selected for your application.

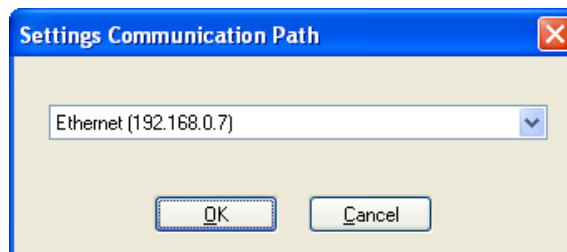

Figure 4-45 Setting the communication path

UM EN PROFINET CTRL DEV

Successful execution of the service will be displayed in the status window.

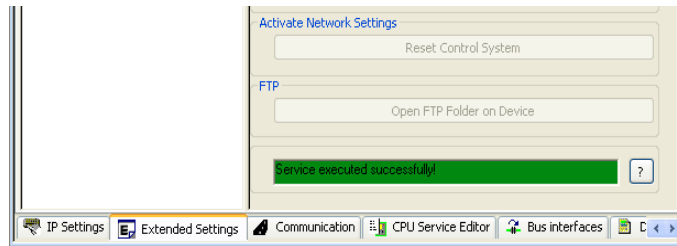

Figure 4-46 Status window

The input/output data ranges available for the ILC 170 ETH 2TX as PROFINET IO device are displayed under "Network Settings" -> "PROFINET Device".

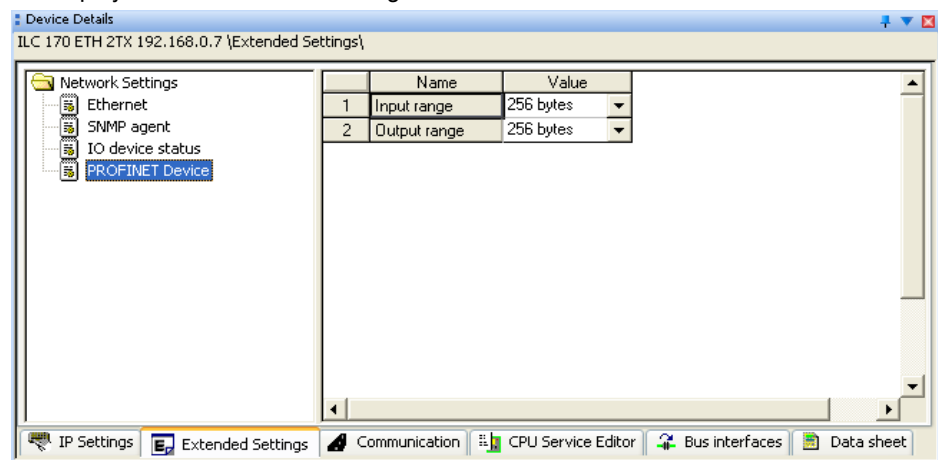

Figure 4-47 Input/output data ranges

Setting the update task

To set the update task, select the device resource in the Bus Structure window.

- Set the update task to "DEFAULT".

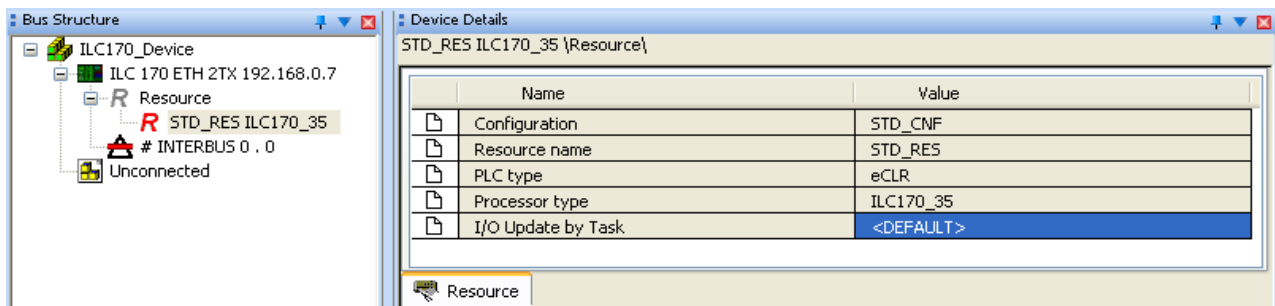

Figure 4-48 Setting the update task

Description of a typical application (devices in several networks)

4.2.5 Observe startup behavior

To use the PROFINET device functions, the following conditions apply for the "ILC330_Controller" project.

Higher-level controller: ILC 330 PN
Controller settings:
 IP address: 192.168.1.2
 Subnet mask: 255.255.255.0
 PROFINET device name: ILC330PN1

RFC 470 PN-3TX settings as a PROFINET IO device

IP address: 192.168.1.5
 Subnet mask: 255.255.255.0
 PROFINET device name: RFC470PN1

To use the PROFINET device functions, the following conditions apply for the "RFC470_Device" project.

RFC 470 PN-3TX settings as a PROFINET IO controller

IP address: 192.168.0.5
 Subnet mask: 255.255.255.0
 PROFINET device name: RFC470PN1

ILC 170 ETH 2TX settings as PROFINET IO device:

IP address: 192.168.0.7
 Subnet mask: 255.255.255.0
 PROFINET device name: ILC170ETH1



Please make sure that the same PROFINET device name of the RFC 470 PN-3TX IO controller (here: RFC470PN1) is used in the lower-level project as in the higher-level project for the RFC 470 PN-3TX as a device (here: RFC140PN1).

Starting up the controller is the easiest way to check whether

- The controller is correctly parameterized
- The I/O devices have the right name
- There are double names or double IP addresses in the system.

Make sure that the controller has the IP address that was set in the project. Start the project control dialog via the menu bar.

If the message "Timeout" appears after 10 seconds, the project and device addresses do not match. It is also possible that the IP address of the computer has not been set correctly.

UM EN PROFINET CTRL DEV

The controller can be reset from the project control dialog. The existing project will be deleted. Start the download and perform a cold reset. Afterwards the BF LEDs must go out on all devices.

To access the network status from the program, the following system variables are mapped in the global variables of the programming environment. Activate the "Debug On" operating mode and the values of these variables will be displayed.

| Global variable | Description |
|---------------------------|---|
| PNIO_CONFIG_STATUS_ACTIVE | Connection to these devices is being established or has been completed. |
| PNIO_CONFIG_STATUS_READY | The connection establishment to the devices has been completed. |

Description of a typical application (devices in several networks)

4.2.6 Checking the program start of the higher-level project

- Open the "ILC330_Controller" project.

When the program is started correctly, the following screen will be shown in the Debug mode:

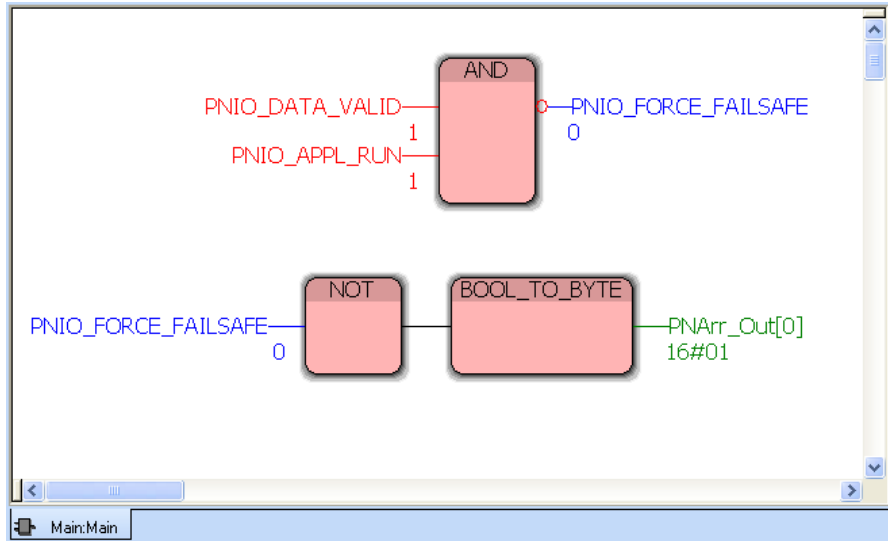

Figure 4-49 Program status

The PNI0_FORCE_FAILSAFE variable is in the FALSE state, thus communication is ensured and the outputs are set according to the process data.

If you remove the voltage connector of the RFC 470 PN-3TX or change the device to the "Stop Mode", the status of PNI0_FORCE_FAILSAFE will change to TRUE. All outputs will be set to "0" and the value "1" is no longer transferred to the device.

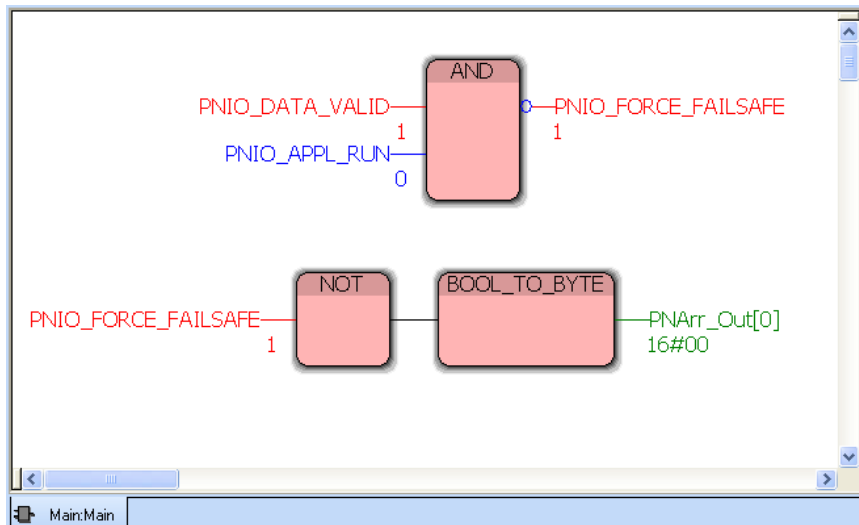

Figure 4-50 Program status in "Stop Mode"

4.2.7 Checking the program start of the lower-level project

The behavior described before can also be observed in the ILC170_Device project. Please note that the RFC 470 PN-3TX is operating as a master and as a slave at the same time. It acts as the link between the ILC 330 PN controller and the ILC 170 2TX controller.

- Please open the lower-level project of the ILC 170 ETH 2TX.
- Then open the "Data_Acknowledge" POU and activate the Debug mode. The following screen appears:

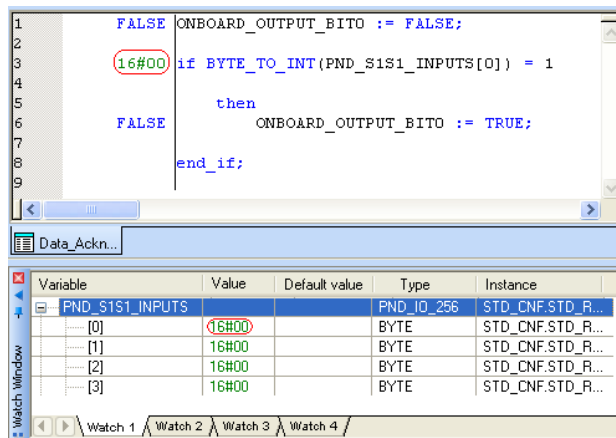

Figure 4-51 Program status active

The value 1 is in array [0] of the PND_S1S1_INPUTS. The ONBOARD_OUTPUT_BIT0 variable is TRUE and the Q1 LED on the ILC 170 2TX is ON. Now switch the PROFINET IO controller (ILC 330 PN and/or RFC 470 PN-3TX) to stop. Communications is terminated and the value is set to 0. The LED goes out as well, because the ONBOARD_INPUT_BIT0 variable is reset to FALSE.

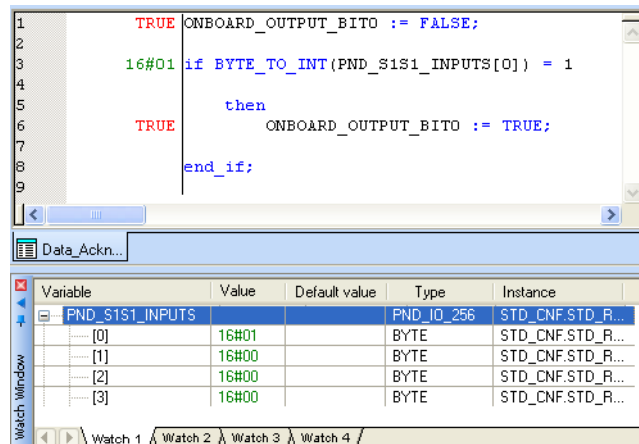

Figure 4-52 Program is stopped

When communication is interrupted by removing the voltage connector of the ILC 170 device, a BF error appears on the RFC display at the PROFINET controller.



If you need more detailed information, call the Diag+ diagnostic tool from PC WorX under View-> Diag+. Here you connect explicitly to a controller and receive further information.



SCATTERGOOD & JOHNSON LTD

ELECTRICAL ENGINEERING & FLUID CONTROL DISTRIBUTORS

Est.1899

At Scattergood & Johnson Ltd, we pride ourselves on being a technical distributor to specialist industries.

Working with a range of quality product suppliers across a number of specialist markets, we are not your average 'box shifter' - we are your technical and supply chain partner.

We fully support every product we sell - for free! Our internal team and external sales engineers can answer any product or application question, no matter the complexity.

Backing up this technical ability is a range of 50,000+ products available from stock for nationwide next day delivery (same day if required!), or you can collect what you need from any of our trade counters around the UK.

Select your specialist interest below to learn more about how we can help.



Online, In Branch and On the Road - Scattergood & Johnson Ltd, there when you need us.

www.scatts.co.uk