

# IB IL 24 DO 16-ME

**Inline digital output terminal, Inline ME versions  
(machine edition), 16 outputs, 24 V DC, 500 mA**



Data sheet  
7445\_en\_01

© PHOENIX CONTACT 2015-03-17

## 1 Description

The terminal is designed for use within an Inline station. It is used to output digital signals.

### Features

- Connections for 16 digital actuators
- Connection of actuators in 2 and 3-wire technology
- Nominal current per output: 0.5 A
- Total current of the terminal: 8 A
- Short-circuit and overload protected outputs
- Diagnostic and status indicators



This data sheet is only valid in association with the IL SYS INST UM E user manual.



Make sure you always use the latest documentation.  
It can be downloaded from the product at [phoenixcontact.net/products](http://phoenixcontact.net/products).

---

<b>2</b>	<b>Table of contents</b>	
1	Description .....	1
2	Table of contents .....	2
3	Ordering data .....	3
4	Technical data .....	3
5	Additional tables .....	6
	5.1 Output characteristic curve.....	6
	5.2 Power dissipation .....	6
	5.3 Limitation of simultaneity, derating .....	6
6	Internal circuit diagram .....	7
7	Terminal point assignment.....	8
8	Connection notes and examples .....	8
9	Local status and diagnostic indicators .....	9
10	Process data.....	10

### 3 Ordering data

Description	Type	Order No.	Pcs. / Pkt.
Inline digital output terminal, Inline ME versions (machine edition) complete with accessories (connector and labeling field), 16 outputs, 24 V DC, 500 mA, 2, 3-conductor connection method	IB IL 24 DO 16-ME	2897253	4
Accessories	Type	Order No.	Pcs. / Pkt.
Connector, for digital 1, 2 or 8-channel Inline terminals (Connector/Adapter)	IB IL SCN-8	2726337	10
Labeling field, width: 12.2 mm (Marking)	IB IL FIELD 2	2727501	10
Insert strip, Sheet, white, unlabeled, can be labeled with: Office printing systems, Plotter: Laser printer, Mounting type: Insert, Lettering field: 62 x 10 mm (Marking)	ESL 62X10	0809492	1
Inline terminal for power distribution (GND), complete with accessories, (connector and labeling field) connections for GND	IB IL PD GND-PAC	2862990	1
VARIOFACE front adapter for Inline modules, for transferring 16 (2 x 8) digital output signals. (Connector/Adapter)	FLKM 14-PA-INLINE/OUT16	2302764	1
Documentation	Type	Order No.	Pcs. / Pkt.
Application note, English, The safety-related segment circuit	AH EN IL SAFE	-	-
Data sheet, English, INTERBUS addressing	DB GB IBS SYS ADDRESS	-	-

### 4 Technical data

#### Dimensions (nominal sizes in mm)

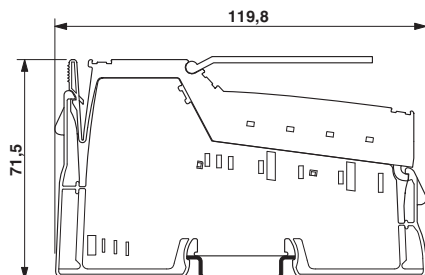

Width	48.8 mm
Height	119.8 mm
Depth	71.5 mm
Note on dimensions	Housing dimensions

#### General data

Color	green
Weight	190 g (with connectors)
Operating mode	Process data mode with one word
Ambient temperature (operation)	-25 °C ... 55 °C
Ambient temperature (storage/transport)	-25 °C ... 85 °C
Permissible humidity (operation)	10 % ... 95 % (according to DIN EN 61131-2)

**General data**

Permissible humidity (storage/transport)	10 % ... 95 % (according to DIN EN 61131-2)
Air pressure (operation)	70 kPa ... 106 kPa (up to 3000 m above sea level)
Air pressure (storage/transport)	70 kPa ... 106 kPa (up to 3000 m above sea level)
Degree of protection	IP20
Protection class	III, IEC 61140, EN 61140, VDE 0140-1

**Connection data**

Designation	Inline connector
Connection method	Spring-cage connection
Conductor cross section solid / stranded	0.08 mm <sup>2</sup> ... 1.5 mm <sup>2</sup> / 0.08 mm <sup>2</sup> ... 1.5 mm <sup>2</sup>
Conductor cross section [AWG]	28 ... 16
Stripping length	8 mm

**Interface Inline local bus**

Connection method	Inline data jumper
Transmission speed	500 kBit/s
Transmission physics	Copper

**Power consumption**

Segment supply voltage $U_S$	24 V DC (nominal value)
Current consumption from $U_S$	max. 8 A
Communications power $U_L$	7.5 V DC
Current consumption from $U_L$	max. 90 mA
Power consumption	max. 0.675 W (at $U_L$ )

**Digital outputs**

Number of outputs	16
Connection method	Spring-cage connection
Connection method	2, 3-wire
Nominal output voltage	24 V DC (voltage difference at $I_{nom} \leq 1$ V)
Voltage difference with nominal current	$\leq 1$ V
Maximum output current per channel	500 mA
Maximum output current per device	8 A
Nominal load, ohmic	12 W (48 $\Omega$ )
Nominal load, inductive	12 VA (1.2 H; 50 $\Omega$ )
Nominal load, lamp	12 W
Signal delay when switching on an ohmic nominal load	typ. 500 $\mu$ s
Signal delay when switching on an inductive nominal load	typ. 100 ms (1.2 H; 50 $\Omega$ )
Signal delay when switching on a lamp nominal load	typ. 100 ms (for switching frequencies up to 8 Hz; above this frequency, the lamp load behaves like an ohmic load)
Signal delay when switching off an ohmic nominal load	typ. 1 ms
Signal delay when switching off an inductive nominal load	typ. 50 ms (1.2 H; 50 $\Omega$ )
Signal delay when switching off a lamp nominal load	typ. 1 ms
Maximum operating frequency with ohmic nominal load	max. 300 Hz (this switching frequency is limited by the number of bus devices, the structure of the bus, the software used and the control or computer system used)
Maximum operating frequency with inductive nominal load	max. 0.5 Hz (1.2 H; 50 $\Omega$ )
Maximum operating frequency with lamp nominal load	max. 8 Hz (this switching frequency is limited by the number of bus devices, the structure of the bus, the software used and the control or computer system used)
Reaction time with short-circuit	ca. 3 s
Reaction time with ohmic overload	ca. 3 s
Behavior at voltage switch-off	The output follows the power supply without delay

**Digital outputs**

Output data validity	typ. 5 ms (after switching the 24 V voltage supply (power up))
One-time unsolicited energy	400 mJ
Limitation of the voltage induced on circuit interruption	-46 V ... -15 V
Output voltage when switched off	max. 2 V
Output current when switched off	max. 300 µA
Behavior with overload	Auto restart
Behavior with inductive overload	Output can be destroyed
Restart frequency with ohmic overload	400 Hz
Restart frequency with lamp overload	400 Hz
Reverse voltage resistance to short pulses	Reverse voltage proof
Resistance to permanent reverse voltage	to 2 A DC
Resistance to permanently applied surge voltage	No
Overcurrent shut-down	min. 0.7 A
Output current with ground connection interrupt when switched off	max. 25 mA
Switching capacity	typ. 100 mW (In the case of ground connection interrupt; at 1 kΩ load resistance)
Inrush current	max. 1.5 A (for 20 ms)
Overload protection, short-circuit protection of outputs	Zener diode in output chip The four channels are thermally coupled, i.e. an error in one channel can also influence the other channels.

**Programming data (INTERBUS, local bus)**

ID code (hex)	BD
ID code (dec.)	189
Length code (hex)	01
Length code (dec.)	01
Process data channel	16 Bit
Input address area	0 Byte
Output address area	2 Byte
Parameter channel (PCP)	0 Byte
Register length (bus)	16 Bit



For the programming data/configuration data of other bus systems, please refer to the corresponding electronic device data sheet (e.g., GSD, EDS).

**Configuration and parameter data in a PROFIBUS system**

Required parameter data	4 Byte
Need for configuration data	4 Byte

**Error messages to the higher level control or computer system**

Short-circuit / overload of the digital outputs	Error message in the diagnostic code (bus) and display (2 Hz) via the LED (D) on the module
---	---

**Electrical isolation/isolation of the voltage areas**

Test section	Test voltage
7.5 V supply (bus logics)/24 V supply (I/O)	500 V AC, 50 Hz, 1 min
7.5 V supply (bus logics) / functional earth ground	500 V AC, 50 Hz, 1 min
24 V supply (I/O) / functional earth ground	500 V AC, 50 Hz, 1 min



To achieve electrical isolation between the logic level and the I/O area, supply these areas from separate power supply units. Interconnection of the power supply units in the 24 V area is not permitted (see also user manual).

## Approvals

For the latest approvals, please visit [phoenixcontact.net/products](http://phoenixcontact.net/products).

## 5 Additional tables

### 5.1 Output characteristic curve

Output characteristic curve when switched on (typical)	
Output current (A)	Differential output voltage (V)
0	0
0.1	0.04
0.2	0.08
0.3	0.12
0.4	0,16
0.5	0,20

### 5.2 Power dissipation

Formula for calculating the power dissipation of the electronics

$$P_{EL} = 0,19 \text{ W} + \sum_{i=1}^n (0,10 \text{ W} + I_{Li}^2 \times 0,40 \Omega)$$

Where:

- $P_{EL}$  Total power dissipation in the terminal
- $i$  Continuous index
- $n$  Number of set outputs ( $n = 1 \dots 16$ )
- $I_{Li}$  Load current of output  $i$

### Power dissipation of the housing

2.7 W maximum (within the permissible operating temperature)

### 5.3 Limitation of simultaneity, derating

Ambient temperature $T_{amb}$	Maximum load current	
	100 % simultaneity	75 % simultaneity
$-25^{\circ}\text{C} \leq T_A < +40^{\circ}\text{C}$	0.50 A	0.50 A
$+40^{\circ}\text{C} \leq T_A < +45^{\circ}\text{C}$	0.45 A	0.50 A
$+45^{\circ}\text{C} \leq T_A < +50^{\circ}\text{C}$	0.40 A	0.50 A
$+50^{\circ}\text{C} < T_A \leq +55^{\circ}\text{C}$	0.35 A	0.50 A

If all channels are used, the permissible working point must be defined according to the above-stated formula.



An example for calculating the working point can be found in the user manual IL SYS INST UM E.

## 6 Internal circuit diagram

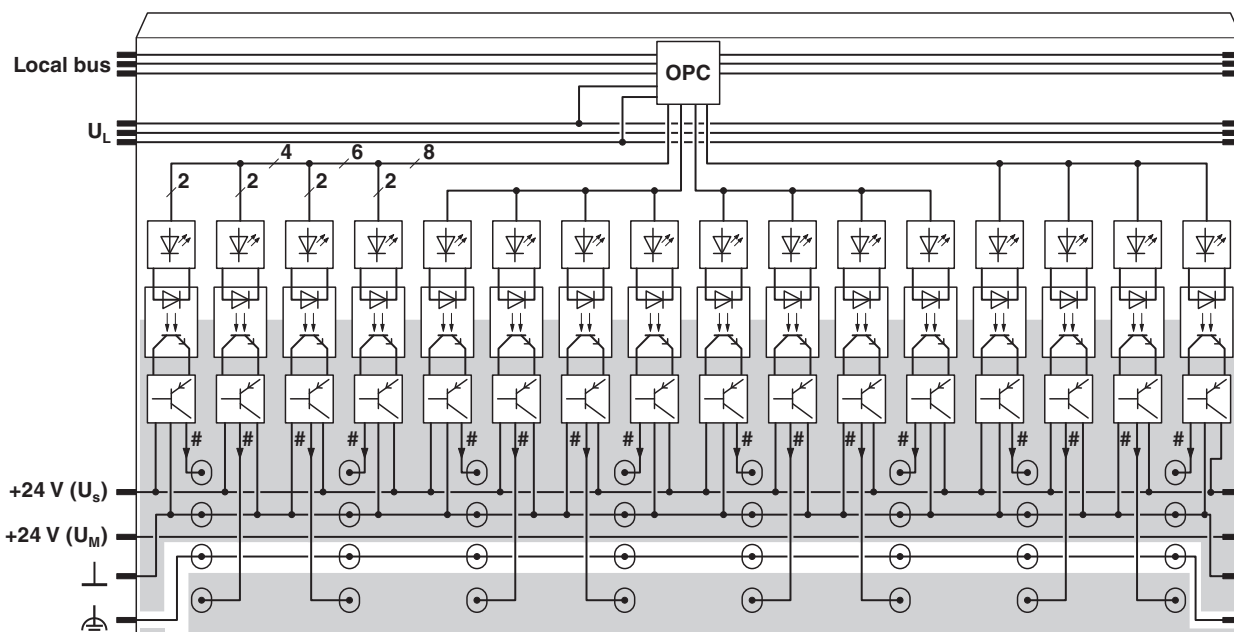





Figure 1 Internal wiring of the terminal points

Key:

 Protocol chip  
(Bus logic including voltage conditioning)

 LED (status indicator)

 Optocoupler

 Transistor

 Digital output

 Electrically isolated area

 Explanation for other used symbols has been provided in the IL SYS INST UM E user manual.

## 7 Terminal point assignment

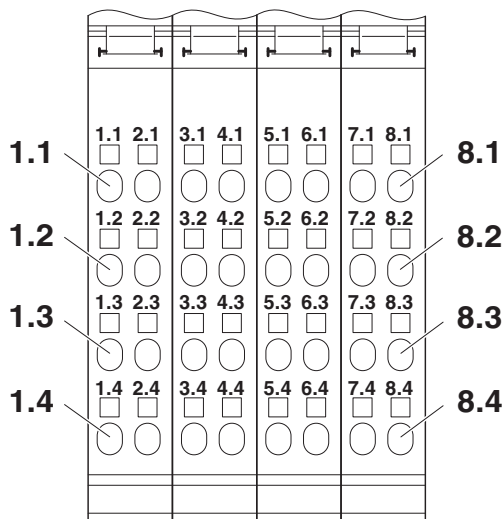

Figure 2 Terminal point assignment

Terminal point	Assignment
1.1 / 2.1	Signal output (OUT 1 / OUT 2)
1.2 / 2.2	Ground contact (GND) for 2 and 3-wire connection
1.3 / 2.3	FE connection for 3-wire connection
1.4 / 2.4	Signal output (OUT 3 / OUT 4)

Terminal point	Assignment
3.1 / 4.1	Signal output (OUT 5 / OUT 6)
3.2 / 4.2	Ground contact (GND) for 2 and 3-wire connection
3.3 / 4.3	FE connection for 3-wire connection
3.4 / 4.4	Signal output (OUT 7 / OUT 8)

Terminal point	Assignment
5.1 / 6.1	Signal output (OUT 9 / OUT 10)
5.2 / 6.2	Ground contact (GND) for 2 and 3-wire connection
5.3 / 6.3	FE connection for 3-wire connection
5.4 / 6.4	Signal output (OUT 11 / OUT 12)

Terminal point	Assignment
7.1 / 8.1	Signal output (OUT 13 / OUT 14)
7.2 / 8.2	Ground contact (GND) for 2 and 3-wire connection
7.3 / 8.3	FE connection for 3-wire connection
7.4 / 8.4	Signal output (OUT 15 / OUT 16)

## 8 Connection notes and examples

**i** When connecting the actuators, observe the assignment of the terminal points to the process data.

**!** **NOTE: Malfunction**  
GND of the actuators and GND of the supply voltage  $U_S$ , which supply the actuators, must have the same potential.

The simplest way to meet this requirement is to use the IB IL PD GND-PAC terminal. Wire the GND connections for the actuators to these terminals. In this way, they are connected with the potential jumper GND of the Inline station.

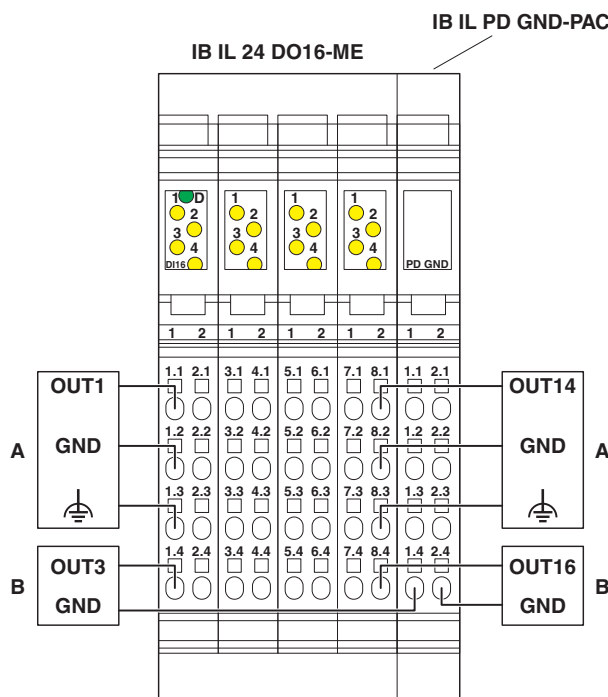

Figure 3 Typical connection of actuators when using the IB IL PD GND-PAC terminal

- A 3-wire connection
- B 2-wire connection

The actuators can also be connected via external busbars. Ensure that GND of the actuators and GND for  $U_S$  have the same potential.

When using external power rails, make sure that the ground (GND) has a reference to the Inline system ground.

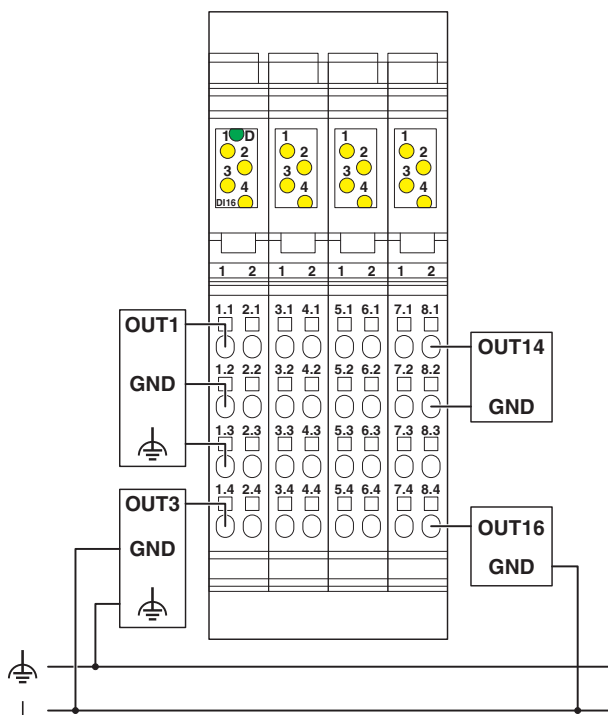

Figure 4 Typical connection of actuators when using external busbars

## 9 Local status and diagnostic indicators

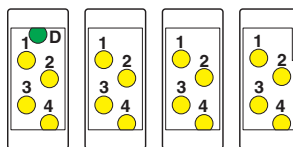

Figure 5 Local status and diagnostic indicators

Designation	Color	Meaning
D	Green	Diagnostics (bus and logic voltage)
<b>For each plug</b>		
1 ... 4	Yellow	Status of the outputs

### Function identification

Pink

## 10 Process data

### Assignment of the terminal points to the output process data

(Word.bit) view	Word	Word 0															
		Bit	15	14	13	12	11	10	9	8	7	6	5	4	3	2	1
(Byte.Bit) view	Byte	Byte 0								Byte 1							
		Bit	7	6	5	4	3	2	1	0	7	6	5	4	3	2	1
Assignment	Slot	4				3				2				1			
	Terminal point (signal)	8.4	7.4	8.1	7.1	6.4	5.4	6.1	5.1	4.4	3.4	4.1	3.1	2.4	1.4	2.1	1.1
	Terminal point (GND)			8.2	7.2			6.2	5.2			4.2	3.2			2.2	1.2
	Terminal point (GND)			8.3	7.3			6.3	5.3			4.3	3.3			2.3	1.3
Status indicator	Slot	4				3				2				1			
	LED	4	3	2	1	4	3	2	1	4	3	2	1	4	3	2	1



For the assignment of the illustrated (byte.bit) view to your INTERBUS control or computer system, please refer to the DB GB IBS SYS ADDRESS data sheet.

For the assignment of the illustrated (byte.bit) view to controllers of other bus systems, please refer to the AH IB IL 24 DI/DO 16 ADDRESS document.



# SCATTERGOOD & JOHNSON LTD

ELECTRICAL ENGINEERING & FLUID CONTROL DISTRIBUTORS

Est.1899

At Scattergood & Johnson Ltd, we pride ourselves on being a technical distributor to specialist industries.

Working with a range of quality product suppliers across a number of specialist markets, we are not your average 'box shifter' - we are your technical and supply chain partner.

We fully support every product we sell - for free! Our internal team and external sales engineers can answer any product or application question, no matter the complexity.

Backing up this technical ability is a range of 50,000+ products available from stock for nationwide next day delivery (same day if required!), or you can collect what you need from any of our trade counters around the UK.

Select your specialist interest below to learn more about how we can help.



Online, In Branch and On the Road - Scattergood & Johnson Ltd, there when you need us.

# [www.scatts.co.uk](http://www.scatts.co.uk)