



# AUTOMATION

## User Manual

### Inline module with integrated safety logic and safe digital outputs

2019-08-09

---

Designation: UM EN IB IL 24 LPSDO 8-PAC

Revision: 04

This user manual is valid for:

Designation	From Version	Order No.
IB IL 24 LPSDO 8-PAC	HW/FW/FW: 00/100/100	2916024

## Please observe the following notes

In order to ensure the safe use of the product described, you have to read and understand this manual. The following notes provide information on how to use this manual.

### User group of this manual

The use of products described in this manual is oriented exclusively to qualified electricians or persons instructed by them, who are familiar with applicable standards and other regulations regarding electrical engineering and, in particular, the relevant safety concepts.

Phoenix Contact accepts no liability for erroneous handling or damage to products from Phoenix Contact or third-party products resulting from disregard of information contained in this manual.

### Explanation of symbols used and signal words



This is the safety alert symbol. It is used to alert you to potential personal injury hazards. Obey all safety messages that follow this symbol to avoid possible injury or death.



#### **DANGER**

This indicates a hazardous situation which, if not avoided, will result in death or serious injury.



#### **WARNING**

This indicates a hazardous situation which, if not avoided, could result in death or serious injury.



#### **CAUTION**

This indicates a hazardous situation which, if not avoided, could result in minor or moderate injury.

The following types of messages provide information about possible property damage and general information concerning proper operation and ease-of-use.



#### **NOTE**

This symbol and the accompanying text alerts the reader to a situation which may cause damage or malfunction to the device, either hardware or software, or surrounding property.



This symbol and the accompanying text provides additional information to the reader. It is also used as a reference to other sources of information (manuals, data sheets, literature) on the subject matter, product, etc.

**General terms and conditions of use for technical documentation**

Phoenix Contact reserves the right to alter, correct, and/or improve the technical documentation and the products described in the technical documentation at its own discretion and without giving prior notice, insofar as this is reasonable for the user. The same applies to any technical changes that serve the purpose of technical progress.

The receipt of technical documentation (in particular data sheets, installation instructions, manuals, etc.) does not constitute any further duty on the part of Phoenix Contact to furnish information on alterations to products and/or technical documentation. Any other agreement shall only apply if expressly confirmed in writing by Phoenix Contact. Please note that the supplied documentation is product-specific documentation only and that you are responsible for checking the suitability and intended use of the products in your specific application, in particular with regard to observing the applicable standards and regulations. Although Phoenix Contact makes every effort to ensure that the information content is accurate, up-to-date, and state-of-the-art, technical inaccuracies and/or printing errors in the information cannot be ruled out. Phoenix Contact does not offer any guarantees as to the reliability, accuracy or completeness of the information. All information made available in the technical data is supplied without any accompanying guarantee, whether expressly mentioned, implied or tacitly assumed. This information does not include any guarantees regarding quality, does not describe any fair marketable quality, and does not make any claims as to quality guarantees or guarantees regarding the suitability for a special purpose.

Phoenix Contact accepts no liability or responsibility for errors or omissions in the content of the technical documentation (in particular data sheets, installation instructions, manuals, etc.).

The aforementioned limitations of liability and exemptions from liability do not apply, in so far as liability must be assumed, e.g., according to product liability law, in cases of premeditation, gross negligence, on account of loss of life, physical injury or damage to health or on account of the violation of important contractual obligations. Claims for damages for the violation of important contractual obligations are, however, limited to contract-typical, predictable damages, provided there is no premeditation or gross negligence, or that liability is assumed on account of loss of life, physical injury or damage to health. This ruling does not imply a change in the burden of proof to the detriment of the user.

**IB IL 24 LPSDO 8-PAC**

---

**Statement of legal authority**

This manual, including all illustrations contained herein, is copyright protected. Use of this manual by any third party is forbidden. Reproduction, translation, and public disclosure, as well as electronic and photographic archiving or alteration requires the express written consent of Phoenix Contact. Violators are liable for damages.

Phoenix Contact reserves all rights in the case of patent award or listing of a registered design. Third-party products are always named without reference to patent rights. The existence of such rights shall not be excluded.

**How to contact us****Internet**

Up-to-date information on Phoenix Contact products and our Terms and Conditions can be found on the Internet at:

[www.phoenixcontact.com](http://www.phoenixcontact.com).

Make sure you always use the latest documentation.

It can be downloaded at:

[www.phoenixcontact.net/download](http://www.phoenixcontact.net/download).

**Subsidiaries**

If there are any problems that cannot be solved using the documentation, please contact your Phoenix Contact subsidiary.

Subsidiary contact information is available at [www.phoenixcontact.com](http://www.phoenixcontact.com).

**Published by**

PHOENIX CONTACT GmbH & Co. KG

Flachmarktstraße 8

32825 Blomberg

Germany

Phone +49 - (0) 52 35 - 3-00

Fax +49 - (0) 52 35 - 3-4 12 00

Should you have any suggestions or recommendations for improvement of the contents and layout of our manuals, please send your comments to

[tecdoc@phoenixcontact.com](mailto:tecdoc@phoenixcontact.com).

# Table of Contents

1	For your safety .....	1-1
1.1	General safety notes.....	1-1
1.2	Electrical safety .....	1-3
1.3	Safety of the machine or system.....	1-4
1.4	Safety for starting applications.....	1-5
1.5	Directives and standards .....	1-6
1.6	Correct usage.....	1-6
1.7	Documentation .....	1-7
1.8	Abbreviations used .....	1-8
1.9	Safety hotline.....	1-8
2	Product description.....	2-1
2.1	Note about the system description .....	2-1
2.2	Brief description of the safety module.....	2-1
2.3	Structure of the safety module .....	2-2
2.4	Housing dimensions .....	2-3
2.5	Safe digital outputs .....	2-4
2.6	Connection options for actuators depending on the parameterization .....	2-6
2.7	Local diagnostic and status indicators .....	2-7
2.8	Safe state .....	2-9
2.8.1	Operating state .....	2-9
2.8.2	Error detection in I/O devices .....	2-9
2.8.3	Device errors .....	2-10
2.8.4	Parameterization errors .....	2-10
2.9	Process data words .....	2-11
2.10	Programming data/configuration data.....	2-11
2.10.1	Local bus .....	2-11
2.10.2	Other bus systems .....	2-11
3	Inline potential and data routing, and Inline connectors .....	3-1
3.1	Inline potential and data routing.....	3-1
3.2	Supply voltage $U_L$ .....	3-1
3.3	Supply voltage $U_M$ .....	3-2
3.4	Terminal point assignment.....	3-4

**IB IL 24 LPSDO 8-PAC**

<b>4</b>	<b>Assembly, removal, and electrical installation.....</b>	<b>4-1</b>
4.1	Assembly and removal .....	4-1
4.1.1	Unpacking the module .....	4-1
4.1.2	General .....	4-1
4.1.3	Setting the DIP switches .....	4-2
4.1.4	Assembly and removal of the safety module .....	4-4
4.2	Electrical installation .....	4-6
4.2.1	Electrical installation of the Inline station .....	4-6
4.2.2	Electrical installation of the safety module .....	4-6
<b>5</b>	<b>Parameterization of the safety module.....</b>	<b>5-1</b>
5.1	Parameterization of the safety module in a SafetyBridge system .....	5-1
5.2	Parameterization of the safe outputs .....	5-2
5.3	Behavior of the outputs in the event of enabled switch-off delay for stop category 1 .....	5-4
<b>6</b>	<b>Connection examples for safe outputs.....</b>	<b>6-1</b>
6.1	Explanation of the examples.....	6-1
6.2	Notes on the protective circuit for external relays/contactors (free running circuit).....	6-2
6.3	Measures required to achieve a specific safety integrity level .....	6-3
6.4	Single-channel assignment of safe outputs .....	6-5
6.5	Two-channel assignment of safe outputs .....	6-8
<b>7</b>	<b>Startup and validation .....</b>	<b>7-1</b>
7.1	Initial startup .....	7-1
7.2	Restart after replacing a safety module .....	7-3
7.2.1	Replacing a safety module .....	7-3
7.2.2	Restart .....	7-3
7.3	Validation.....	7-3
<b>8</b>	<b>Errors: Messages and removal .....</b>	<b>8-1</b>
8.1	Safe digital output errors.....	8-3
8.2	Supply voltage errors.....	8-4
8.3	Parameterization errors .....	8-5
8.4	General errors .....	8-6
8.5	Connection errors to satellites .....	8-7
8.6	PCP errors when transferring the parameterization to the IB IL 24 LPSDO 8-PAC.....	8-8
8.7	Acknowledging an error.....	8-9

---

**Table of Contents**

9	Maintenance, repair, decommissioning, and disposal .....	9-1
9.1	Maintenance.....	9-1
9.2	Repair.....	9-1
9.3	Decommissioning and disposal.....	9-1
10	Technical data and ordering data .....	10-1
10.1	System data .....	10-1
10.1.1	Inline .....	10-1
10.1.2	SafetyBridge system .....	10-1
10.2	IB IL 24 LPSDO 8-PAC.....	10-1
10.3	Conformance with EMC Directive.....	10-6
10.4	Ordering data .....	10-7
10.4.1	Ordering data: Safety module .....	10-7
10.4.2	Ordering data: Accessories .....	10-7
10.4.3	Ordering data: Software .....	10-7
10.4.4	Ordering data: Documentation .....	10-7
A	Appendix: SafetyBridge system.....	A-1
A 1	The SafetyBridge system .....	A-1
A 1.1	SafetyBridge technology – Maximum flexibility and safety .....	A-1
A 1.2	Overview of SafetyBridge system features .....	A-2
A 2	System topology.....	A-2
A 2.1	General topology .....	A-2
A 2.2	Network and controller requirements .....	A-3
A 2.3	Safe input and output devices .....	A-4
A 3	SafetyBridge address assignment.....	A-5
A 4	Operating modes and setting the DIP switches in the SafetyBridge system .....	A-8
A 4.1	Module switch positions .....	A-9
A 4.2	SafetyBridge multiplexer mode .....	A-10
A 5	Process image.....	A-12
A 5.1	Structure of the process image .....	A-12
A 5.2	Descriptions of the registers .....	A-14
A 5.3	Mirroring of local safe output data .....	A-17
A 6	Implementation of data flow between the standard control system and the safety modules .....	A-18
A 6.1	Implementation of data flow with a function block .....	A-18
A 6.2	Implementation of data flow without a function block .....	A-18
A 7	Enable principle.....	A-18
A 8	Diagnostics.....	A-20
A 8.1	Error detection in I/O devices .....	A-20
A 8.2	Detection of device errors .....	A-20
A 8.3	Acknowledgment of error messages for remote modules (satellites) .....	A-21

**IB IL 24 LPSDO 8-PAC**

A 9	Configuration, parameterization, and download .....	A-21
A 9.1	Configuration and parameterization using the SAFECONF tool .....	A-21
A 9.2	Downloading the configuration and parameter data record following power up .....	A-22
A 9.3	Implementing modular system concepts .....	A-22
A 10	Safe state .....	A-23
A 11	Time response in the SafetyBridge system .....	A-24
A 11.1	Typical response time .....	A-24
A 11.2	Shutdown time .....	A-25
A 12	Achievable safety depending on the modules used.....	A-27
A 13	Behavior in the event of an error.....	A-29
A 13.1	Critical system or device errors .....	A-29
A 13.2	Parameterization or configuration errors .....	A-30
A 13.3	Communication errors .....	A-30
A 13.4	Peripheral faults .....	A-30
A 14	Startup and restart.....	A-31
A 14.1	Startup/restart following power up .....	A-31
A 14.2	Restart after triggering a safety function .....	A-31
A 15	Memory sizes for the safety logic.....	A-31
<b>B</b>	<b>Appendix: Checklists .....</b>	<b>B-1</b>
B 1	Checklists for the SafetyBridge system .....	B-2
B 1.1	Planning .....	B-2
B 1.2	Configuration and parameterization .....	B-4
B 1.3	Startup .....	B-5
B 1.4	Safety functions .....	B-6
B 1.5	Validation .....	B-7
B 2	Checklists for the IB IL 24 LPSDO 8-PAC module.....	B-8
B 2.1	Planning .....	B-8
B 2.2	Assembly and electrical installation .....	B-10
B 2.3	Startup .....	B-11
B 2.4	Validation .....	B-12
<b>C</b>	<b>Appendix: Index.....</b>	<b>C-1</b>
<b>D</b>	<b>Appendix: Revision history .....</b>	<b>D-1</b>

# 1 For your safety

## Purpose of this manual

The information in this document is designed to familiarize you with how the IB IL 24 LPSDO 8-PAC safety module works, its operating and connection elements, and its parameter settings. This information will enable you to use the module within a SafetyBridge system according to your requirements.

## Validity of the user manual

This manual is only valid for the IB IL 24 LPSDO 8-PAC module in the version indicated on the inner cover page.

## 1.1 General safety notes



**WARNING: Depending on the application, incorrect handling of the safety module can pose serious risks for the user**

When working with the safety module within the SafetyBridge system, please observe all the safety notes included in this section.

### Requirements

Knowledge of the following is required:

- The target system (e.g., INTERBUS, PROFIBUS, PROFINET)
- The standard control system
- The SafetyBridge system (see Appendix A)
- The components used in your application
- The Inline product range
- Operation of the software tools used
- Safety regulations in the field of application

### Qualified personnel

In the context of the use of the SafetyBridge system, the following operations may only be carried out by qualified personnel:

- Planning
- Configuration of the safety logic and parameterization
- Installation, startup, servicing
- Maintenance, decommissioning

This user manual is therefore aimed at:

- Qualified personnel who plan and design safety equipment for machines and systems and are familiar with regulations governing safety in the workplace and accident prevention.
- Qualified personnel, who install and operate safety equipment in machines and systems.

In terms of the safety notes in this manual, qualified personnel are persons who, because of their education, experience and instruction, and their knowledge of relevant standards, regulations, accident prevention, and service conditions, have been authorized to carry out any required operations, and who are able to recognize and avoid any possible dangers.

**IB IL 24 LPSDO 8-PAC**

---

<b>Documentation</b>	You must observe all information in this manual as well as in the documents listed in "Documentation" on page 1-7.
<b>Safety of personnel and equipment</b>	The safety of personnel and equipment can only be assured if the safety module is used correctly (see "Correct usage" on page 1-6).
<b>Error detection</b>	Depending on the wiring and the corresponding setting of the safe output module parameters, the SafetyBridge system can detect various errors within the safety equipment.
<b>Transmission speed</b>	Only use devices with a uniform transmission speed within an Inline station (a local bus). A mixture of devices with different transmission speeds cannot be operated.
<b>Do not carry out any repairs</b>	Repair work may not be carried out on the safety module. In the event that an error cannot be removed, please contact Phoenix Contact immediately, engage a service engineer or send the faulty module directly to Phoenix Contact.
<b>Do not open the housing/security seal</b>	It is strictly prohibited to open the safety module housing. In order to prevent the manipulation of the safety module and to detect the unauthorized opening of the safety module, a security seal is applied to the module. This security seal is damaged in the event of unauthorized opening. In this case, the correct operation of the safety module can no longer be ensured.
<b>Measures to prevent incorrect connection and polarity reversal</b>	Take measures to prevent the incorrect connection, polarity reversal, and manipulation of connections.

## 1.2 Electrical safety



**WARNING: Hazardous body currents and the loss of functional safety**

Disregarding instructions for electrical safety may result in hazardous currents and the loss of functional safety.

In order to ensure electrical safety, please observe the following points.

**Direct/indirect contact**

Protection against direct and indirect contact according to VDE 0100 Part 410 must be ensured for all components connected to the system. In the event of an error, parasitic voltages must not occur (single-fault tolerance).

This can be achieved by:

- Using power supply units with safe isolation (PELV).
- Decoupling circuits, which are not SELV or PELV systems, using optocouplers, relays, and other components, which meet the requirements of safe isolation.

**Power supply unit**

Only use power supply units with safe isolation and PELV according to EN 50178/VDE 0160 (PELV). This prevents short circuits between primary and secondary sides.

**Insulation rating**

When selecting the operating equipment, please take into consideration the dirt and surge voltages, which may occur during operation.

The IB IL 24 LPSDO 8-PAC module is designed for Surge Voltage Category II (according to DIN EN 60664-1). If you expect surge voltages in the system, which exceed the values defined in Surge Voltage Category II, take into consideration additional measures for voltage limitation.

**Installation and configuration**

Please observe the instructions for installing and configuring the system (see "Documentation" on page 1-7).



**WARNING: Depending on the application, incorrect installation and upgrades can pose serious risks for the user**

The user is obliged to design the devices used and their installation in the system according to these requirements. This also means that existing plants and systems retrofitted with the SafetyBridge system must be checked and tested again in this respect.

### 1.3 Safety of the machine or system

The machine/system manufacturer and the operator bear sole responsibility for the safety of the machine or system and the implemented application, in which the machine or system is used. The Machinery Directive must thus be observed.

#### Draw up and implement a safety concept

In order to use the safety module described in this document, you must have drawn up an appropriate safety concept for your machine or system. This includes a hazard and risk analysis according to the directives and standards specified in "Directives and standards" on page 1-6, as well as a test report (checklist) for validating the safety function (see "Appendix: Checklists" on page B-1).

The target safety integrity level (SIL according to EN 61508, SIL CL according to EN 62061, category according to EN 954-1 or performance level according to EN ISO 13849-1) is ascertained on the basis of the risk analysis. The safety integrity level ascertained determines how to connect and parameterize the safety module within the overall safety function.

Within a SafetyBridge system, the IB IL 24 LPSDO 8-PAC safety module can be used to achieve safety functions with the following requirements depending on the conditions of use:

- Up to category 4 according to standard EN 954-1
- Up to SIL 3 according to standard EN 61508
- Up to SIL CL 3 according to standard EN 62061
- Up to PL e according to standard EN ISO 13849-1



Please also refer to "Achievable safety depending on the modules used" on page A-27.

#### Check hardware and parameterization

Carry out a **validation** every time you make a safety-related modification to your overall system.

Use your test report to ensure that:

- The safe devices are connected to the correct safe sensors and actuators
- The safe input and output devices have been parameterized correctly
- The safety functions have been wired correctly

## 1.4 Safety for starting applications

Consider your machine or system when determining the start conditions:

- Starting the machine or system may only take place when no persons are within the danger zone.
- Comply with the requirements of EN ISO 13849-1 with respect to manual resetting functions.

This applies to:

- Switching on safe devices.
- Acknowledgement of device error messages.
- Acknowledgement of communication errors.
- Acknowledgement of block error messages in the application.
- Removing safeguards for safety functions.

Observe your safety logic during programming/configuring:

- An edge change (zero-one edge) can cause a change from safe status (replacement value = 0) to operating status.
- Include measures in your safety logic that prevent this edge change from starting or restarting of the machine/system unexpectedly!

## 1.5 Directives and standards

The manufacturers and operators of machines and systems, in which the IB IL 24 LPSDO 8-PAC module is used, are responsible for adhering to all applicable directives and legislation.

For the standards observed by the module, please refer to the certificate issued by the approval body and the EC declaration of conformity. These documents are available on the Internet at [www.phoenixcontact.net/catalog](http://www.phoenixcontact.net/catalog).

## 1.6 Correct usage

Only use the SafetyBridge system in accordance with the instructions in this section.

The IB IL 24 LPSDO 8-PAC safety module is designed exclusively for use in a SafetyBridge system.

It can only perform its safety-related tasks within the system if it has been integrated into the execution process correctly and in such a way as to avoid errors.

You must observe all information in this manual as well as in the documents listed in "Documentation" on page 1-7. In particular, only use the module according to the technical data and ambient conditions specified in Section 10, "Technical data and ordering data" on page 10-1 and onwards.

Within a SafetyBridge system, the IB IL 24 LPSDO 8-PAC safety module can be used to achieve safety functions with the following requirements depending on the conditions of use:

- Up to category 4 according to standard EN 954-1
- Up to SIL 3 according to standard EN 61508
- Up to SIL CL 3 according to standard EN 62061
- Up to PL e according to standard EN ISO 13849-1



Please also refer to "Achievable safety depending on the modules used" on page A-27.

It is designed for connecting single-channel or two-channel actuators, which can be used in association with safety technology.

For example, the module can be used in the following applications:

- Safety circuits according to EN 60204 Part 1
- Safe shutdown of contactors, motors (24 V DC), valves, ohmic, inductive, and capacitive loads

The module is **not** suitable for applications, in which stop category 1 also has to be observed in the event of an error (see also "Behavior of the outputs in the event of enabled switch-off delay for stop category 1" on page 5-4).

## 1.7 Documentation

<b>Latest documentation</b>	Make sure you always use the latest documentation. Changes or additions to this document can be found on the Internet at <a href="http://www.phoenixcontact.net/download">www.phoenixcontact.net/download</a> .
<b>SafetyBridge system</b>	<p>When working on the SafetyBridge system and its components, you must always keep this user manual and other items of product documentation to hand and observe the information therein.</p> <p>User manuals:</p> <ul style="list-style-type: none"><li>– For the controller used</li><li>– For SafetyBridge system I/O modules</li><li>– For SafetyBridge system function blocks</li></ul> <p>Please also observe the relevant information about the bus system used.</p>
<b>Inline product range</b>	<p>IL SYS INST UM E</p> <p>Automation terminals of the Inline product range (configuration and installation)</p> <p>Documentation for the bus coupler used</p>

## 1.8 Abbreviations used

Table 1-1 Abbreviations used

Abbreviation	Meaning	Standard	Example
SIL	Safety integrity level	EN 61508	SIL 2, SIL 3
SIL CL	SIL claim limit	EN 62061	SIL CL 3
Cat.	Category	EN 954-1, EN ISO 13849-1	Cat. 2, Cat. 4
PL	Performance level	EN ISO 13849-1	PL e, PL d

Table 1-2 Abbreviations used

Abbreviation	Meaning
SELV	<p>Safety extra-low voltage</p> <p>A circuit in which the voltage cannot exceed 30 V AC, 42.4 V peak value or 60 V DC under normal conditions, and under single-fault conditions, including earth faults in other circuits.</p> <p>A SELV circuit is not connected to protective earth ground.</p> <p>(According to EN 61131-2)</p>
PELV	<p>Protective extra-low voltage</p> <p>A circuit in which the voltage cannot exceed 30 V AC, 42.4 V peak value or 60 V DC under normal conditions, and under single-fault conditions, except earth faults in other circuits.</p> <p>A PELV circuit is like a SELV circuit, but is connected to protective earth ground.</p> <p>(According to EN 61131-2)</p>
EUC	Equipment under control

## 1.9 Safety hotline

Should you have any technical questions, please contact our 24-hour hotline.

Phone: +49 - 52 81 - 94 62 77 7

E-mail: [safety-service@phoenixcontact.com](mailto:safety-service@phoenixcontact.com)

## 2 Product description

### 2.1 Note about the system description

The SafetyBridge system is described in "Appendix: SafetyBridge system" on page A-1.

In the description of the IB IL 24 LPSDO 8-PAC safety module, it is assumed that you are familiar with the SafetyBridge system. If this is not the case, please refer to Appendix A first for information about the system.

### 2.2 Brief description of the safety module

The IB IL 24 LPSDO 8-PAC module is designed for use within an Inline station. The module features integrated configurable safety logic and safe digital outputs.

The IB IL 24 LPSDO 8-PAC safety module can be used as part of an Inline station at any point within a SafetyBridge system.

The transmission speed of the Inline local bus can be set to 500 kbaud or 2 Mbaud on the safety module using switches.

One transmission speed must be used seamlessly in an Inline station.

The module has a 10-pos. DIP switch, which is used to set the SafetyBridge address and operating mode.

The module has four safe positive switching digital outputs for two-channel assignment or eight safe positive switching digital outputs for single-channel assignment.

The outputs can be parameterized according to the application and enable the integration of actuators in the SafetyBridge system.

Within a SafetyBridge system, the IB IL 24 LPSDO 8-PAC safety module can be used to achieve safety functions with the following requirements:

- Up to category 4 according to standard EN 954-1
- Up to SIL 3 according to standard EN 61508
- Up to SIL CL 3 according to standard EN 62061
- Up to PL e according to standard EN ISO 13849-1



Please also refer to "Achievable safety depending on the modules used" on page A-27.

## 2.3 Structure of the safety module

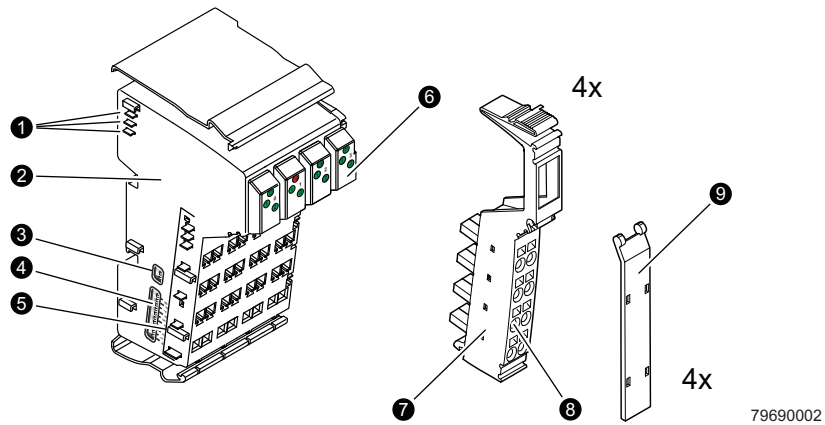

Figure 2-1 Structure of the safety module

- 1 Data jumpers (local bus)
- 2 Electronics base with labeling including version designation hardware/firmware/firmware (not shown)
- 3 Switch for setting the transmission speed and operating mode
- 4 Switch for setting the SafetyBridge address
- 5 Potential jumper
- 6 Diagnostic and status indicators; for assignment and meaning see "Local diagnostic and status indicators" on page 2-7
- 7 Inline connector; for assignment see "Terminal point assignment" on page 3-4
- 8 Terminal points
- 9 Labeling field

## 2.4 Housing dimensions

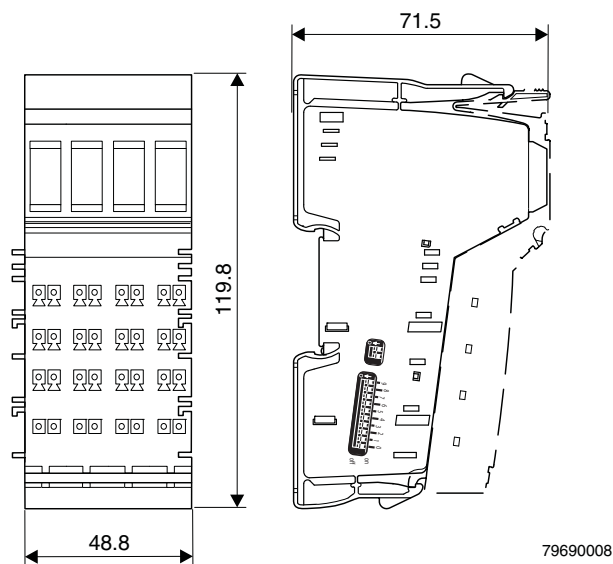

Figure 2-2 Housing dimensions (in mm)

79690008

## 2.5 Safe digital outputs

The safety module has safe positive switching digital outputs, which can be used as follows:

- For two-channel assignment:
  - Four two-channel outputs
- For single-channel assignment:
  - Eight single-channel outputs

### Technical data

For the technical data for the safe outputs, please refer to page 10-4.

### Parameterization

The individual safe digital outputs of a safety module can be parameterized differently. This means that the outputs can be adapted to various operating conditions and different safety integrity levels can be implemented (SIL, SIL CL, Cat., PL).

In order to achieve a high level of error detection, the test pulses must be enabled. If this is not possible for the connected loads, the test pulses can be disabled. However, in this case error detection is reduced.



The safety integrity level (SIL, SIL CL, Cat., PL) and error detection that can be achieved depend on the parameterization, the structure of the actuator, and the cable installation (see "Connection examples for safe outputs" on page 6-1).

For information about parameterization, please refer to "Parameterization of the safe outputs" on page 5-2.

### Diagnostics

Diagnostics are provided via both the local diagnostic indicators and the diagnostic messages, which are transmitted to the controller.

For information about the diagnostic messages of the outputs, please refer to "Safe digital output errors" on page 8-3.



**CAUTION: Diagnostic data is not safety-related**

The diagnostic data is not safety-related. This data must not be used to execute safety-related functions or actions.

### Requirements for controlled devices/actuators



The error detection of the module varies depending on the parameterization. This results in specific requirements for the actuators.

- If the outputs are parameterized with test pulses, the output circuits are tested by test pulses at regular intervals. These test pulses are visible at the output and can trigger undesirable reactions with quick responding actuators.

#### **WARNING: Unintentional machine startup**

If the process does not tolerate this behavior, actuators with sufficient inertia must be used.

In general, the load must not be so dynamic that it causes dangerous states within 1 ms.

Quick actuators, which offer a safety-related response to pulses in under 1 ms, may **not generally** be used.

**Note:** Switching off the test pulses affects the error detection of the module. Please observe the achievable safety integrity level, which is specified in "Connection examples for safe outputs" on page 6-1.

The failure detection time is 20 ms. Please refer to "Single-channel assignment of safe outputs" on page 6-5 and "Two-channel assignment of safe outputs" on page 6-8 for additional information.

- Only use appropriately qualified actuators.
- Use reliable components. These include, for example:
  - Control contactors according to EN 60947-4-1
  - Power contactors
  - Relays with positively driven contacts according to DIN EN 50205
- Use relays or contactors with positively driven N/C contacts to safely monitor the state (pick-up, drop-out).
- Please observe any special environmental requirements in your application when selecting the controlled devices.
- Please note applicable C standards in your application (e.g., EN 1010), in which, for example, the number of controlled devices required to achieve a particular category is specified.

## 2.6 Connection options for actuators depending on the parameterization

Actuators that meet various safety requirements depending on the parameterization can be connected to the outputs. For connection examples, please refer to Section 6, "Connection examples for safe outputs".

The maximum achievable SIL/SIL CL/Cat./PL is specified in the table.

In order to achieve this:

- Observe the information in the connection examples (see Section 6, "Connection examples for safe outputs")
- Observe the requirements of the standards with regard to the external wiring and the actuators to be used to achieve a SIL/SIL CL/Cat./PL (see "Measures required to achieve a specific safety integrity level" on page 6-3)

"Output" parameterization	Output OUT0 to OUT3	
	Single-channel	Two-channel
Test pulses	Any	ON/OFF*
Achievable category	SIL 2/SIL CL 2/Cat. 3/PL d	SIL 3/SIL CL 3/Cat. 4/PL e
For connection example, see page	6-5	6-8

Key:

- \* If the test pulses are disabled, a cross circuit between the outputs is only detected if the output is enabled.



To achieve Cat. 3, two-channel actuators are usually used.

## 2.7 Local diagnostic and status indicators

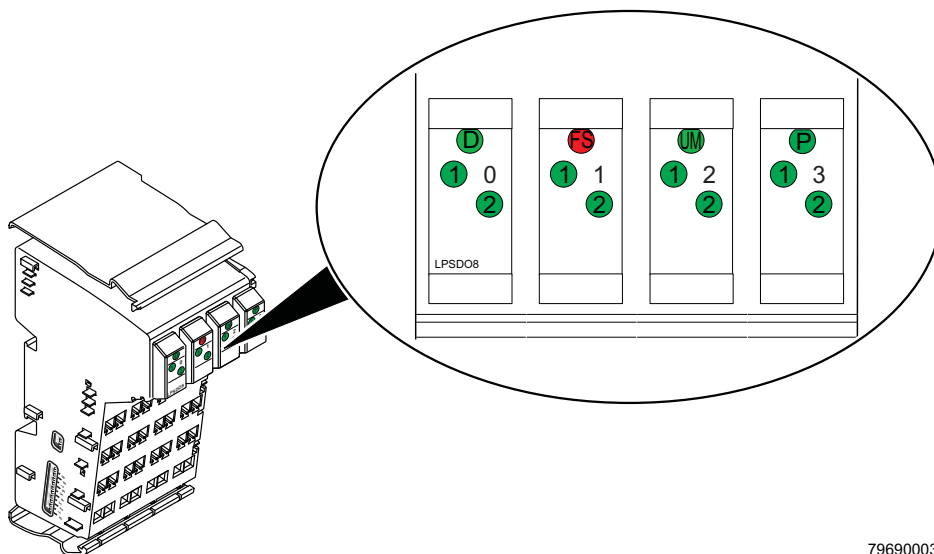



Figure 2-3 Local diagnostic and status indicators on the IB IL 24 LPSDO 8-PAC module

79690003

Table 2-1 Local diagnostic and status indicators

<b>D</b>	Green LED	Diagnostics
	OFF:	Communications power not present
	Flashing at 0.5 Hz:	Communications power present, local bus not active
	Flashing at 4 Hz:	Communications power present, error at the interface between previous and flashing terminal (the terminals after the flashing terminal cannot be addressed). (E.g., loose contact at the bus interface, terminal before the flashing terminal has failed, another terminal was snapped on during operation (not permitted))
	 Observe the module startup time of approximately 16 s. During this time the D LED flashes at 4 Hz and the bus cannot be started up. Start PCP communication with the device and only download the parameterization and configuration data record once the firmware has started up (around 16 s; SA bit = 1 in the LPSDO device register; see Appendix A 5.2 on page A-14).	
ON:	Communications power present, local bus active	
<b>FS</b>	Red LED	Failure state
	Flashing at 1 Hz:	Device not parameterized or parameterization was not accepted
	ON:	Hardware fault Communication to controller disabled and output driver enable reset.

**IB IL 24 LPSDO 8-PAC**

Table 2-1 Local diagnostic and status indicators (continued)

<b>UM</b>	Green LED	Monitoring the supply voltage $U_M$
	OFF:	Communications power not present
	Flashing at 1 Hz:	$U_M$ below the permissible voltage range (undervoltage)
	ON:	$U_M$ present
<b>P</b>	Green LED	Status indicator for communication
	OFF:	IB IL 24 LPSDO 8-PAC not parameterized
	Flashing at 0.5 Hz:	IB IL 24 LPSDO 8-PAC is parameterized, but safe communication is not running to at least one remote device
	ON:	Communication OK  IB IL 24 LPSDO 8-PAC is parameterized and safe communication is running without any errors to all configured remote safe devices.  If a remote device is not configured: the IB IL 24 LPSDO 8-PAC is parameterized.  Corresponds to COK bit = 1 (see "Dev-Diag-LPSDO (diagnostic LPSDO)" on page A-15)
<b>OUT 0.1 - 3.2</b>	Green/red LED	Status of each output (see "Terminal point assignment" on page 3-4)
	Green:	Output at logic 1
	OFF:	Output at logic 0, no error
	Red ON:	Output short circuit/overload (This diagnostic message is stored temporarily on the module. The message is stored in the volatile memory and will be lost after a voltage reset.)
		In the event of an error (red LED ON), the output is switched off until the acknowledgment sent by the controller is received by the safety module (see also "Safe digital output errors" on page 8-3).

## 2.8 Safe state

The safe state for the module is the low state at the output terminals (see "Safe digital outputs" on page 2-4).

The safe state can be entered in the following cases:

1. Operating state
2. Error detection in I/O devices
3. Device errors
4. Parameterization errors

### 2.8.1 Operating state

In the operating state, the outputs can enter states "1" or "0". In general, state "0" is the safe state.



**WARNING: Loss of the safety function possible due to undetected accumulation of errors**

Also evaluate the diagnostics of modules that are not used, but are connected to the power supply, at regular intervals or disconnect these modules from the supply voltage.

### 2.8.2 Error detection in I/O devices

#### Outputs

If an error is detected at an output, the affected output is disabled ("0" = OFF = safe state).

Depending on the parameterization, the following errors can be detected at outputs:

- Short circuit
- Cross circuit
- Overload

The relevant diagnostic message is transmitted to the controller (see "Safe digital output errors" on page 8-3). For information about which errors are detected and when, please refer to "Connection examples for safe outputs" on page 6-1.



If an error occurs on a channel of an output parameterized as "two-channel", the other corresponding channel also enters the safe state.

### 2.8.3 Device errors

#### Outputs

If a hardware fault in the internal circuit is detected at an output, **all** module outputs are disabled ("0" = OFF = safe state).

The relevant diagnostic message is transmitted to the controller (see "Safe digital output errors" on page 8-3).

#### Serious errors

All serious errors that can result in the loss of or adversely affect the safety function cause the entire module to enter the safe state. The FS LED on the safety module is permanently on.

#### The following errors result in the safe state:

- Serious hardware fault in the internal circuit
- User error
- Module overload
- Overheating of the module
- Faulty supply voltage

The relevant diagnostic message is transmitted to the controller (see "Errors: Messages and removal" on page 8-1).



#### **WARNING: Loss of the safety function due to sequential errors**

In the event of a device error, the following measures should be taken to prevent sequential errors:

Disconnect the module from the power supply and replace it.

### 2.8.4 Parameterization errors

Parameterization errors are indicated:

- As long as the module is not parameterized
- or
- In the event of faulty parameterization

Parameterization errors cause the entire module to enter the safe state. The FS LED on the safety module flashes.

In the event of faulty parameterization, the relevant diagnostic message is transmitted to the controller (see "Parameterization errors" on page 8-5).



#### Exception:

If an output is operated in stop category 1 and this output is within the switch-off delay time, then another instance of faulty parameterization results in the entire module switching to the safe state only once the switch-off delay time has elapsed.

## 2.9 Process data words

The module occupies 6 or 16 words in the Inline system. If these words are mapped, please refer to "Process image" on page A-12.

The input data only indicates the actual status of the outputs if no bus errors or device errors are present. Even during the parameterized switch-off delay in stop category 1, the status of the outputs on the module does not correspond to the status of the outputs on the controller.

The parameterization of the outputs determines whether the input data is mapped in single-channel or two-channel mode. The value for "parameterized output" for the outputs is also set for the input data.

## 2.10 Programming data/configuration data

### 2.10.1 Local bus

Protocol	SafetyBridge	SafetyBridge multiplexer
Switch address	Any, 008 <sub>hex</sub> ... 0F8 <sub>hex</sub>	Any, 208 <sub>hex</sub> ... 2F8 <sub>hex</sub>
Operating mode	Mode 1	Mode 1
ID code	C7 <sub>hex</sub> (199 <sub>dec</sub> )	C7 <sub>hex</sub> (199 <sub>dec</sub> )
Length code	12 <sub>hex</sub> (18 <sub>dec</sub> )	0E <sub>hex</sub> (14 <sub>dec</sub> )
Input address area	15 words	5 words
Output address area	15 words	5 words
Parameter channel (PCP)	1 word	1 word
Register length	16 words	6 words

### 2.10.2 Other bus systems



For the programming data/configuration data of other bus systems, please refer to the corresponding electronic device data sheet (e.g., GSD, EDS).

## 3 Inline potential and data routing, and Inline connectors

### 3.1 Inline potential and data routing

For operation, the safety module must be integrated in an Inline station within the SafetyBridge system.

The bus signals are transmitted via the Inline data jumpers. The required supply voltages are transmitted via the Inline potential jumpers.



For more detailed information about potential and data routing within an Inline station, please refer to the IL SYS INST UM E user manual.

The segment circuit is looped through the safety module and is available again after the module. The segment circuit cannot be accessed in the safety module.

### 3.2 Supply voltage $U_L$

Supply the 24 V supply voltage  $U_{BK}/U_{24V}$  at a bus coupler or a suitable power terminal (IB IL 24 PWR IN/R). The 7.5 V voltage  $U_L$  is generated from this 24 V supply voltage in the bus coupler or power terminal. It is supplied to the safety module via the Inline potential jumper  $U_L$ .



**WARNING: Loss of the safety function when using incorrect power supplies**

Please note for the voltage supply at the bus coupler or power terminal that:  
Only power supplies according to EN 50178/VDE 0160 (PELV) may be used.  
Please also observe the points in "Electrical safety" on page 1-3.

The supply voltage  $U_L$  is used to supply the bus controller board and the communications power. For the technical data for supply voltage  $U_L$ , please refer to "Supply voltage  $U_L$  (logic)" on page 10-3.

The maximum current carrying capacity for the supply voltage  $U_L$  is 2 A.

This current carrying capacity can be reduced by certain terminals. Please refer to the information in the terminal-specific data sheets.

### 3.3 Supply voltage $U_M$

Supply the supply voltage at a bus coupler or a power terminal. It is supplied to the safety module via the Inline potential jumper  $U_M$ .



**WARNING: Loss of the safety function when using incorrect power supplies**

Please note for the voltage supply at the bus coupler or power terminal that: Only power supplies according to EN 50178/VDE 0160 (PELV) may be used. Please also observe the points in "Electrical safety" on page 1-3.

Supply voltage  $U_M$  is used to supply the output circuits. For the technical data for supply voltage  $U_M$ , please refer to "Supply voltage  $U_M$  (actuators)" on page 10-3.

The maximum current carrying capacity for the main circuit  $U_M$  is 8 A (total current with the segment circuit that is not used in the safety terminal). This current carrying capacity can be reduced by certain terminals. Please refer to the information in the terminal-specific data sheets.

If the limit value of the potential jumpers  $U_M$  and  $U_S$  is reached (total current of  $U_S$  and  $U_M$ ), a new power terminal must be used.



**NOTE: Module damage due to polarity reversal**

Polarity reversal places a burden on the electronics and, despite protection against polarity reversal, can damage the module. Therefore, polarity reversal must be prevented.

For the behavior of the safety module in the event of an error at the supply voltage, please refer to "Supply voltage errors" on page 8-4.

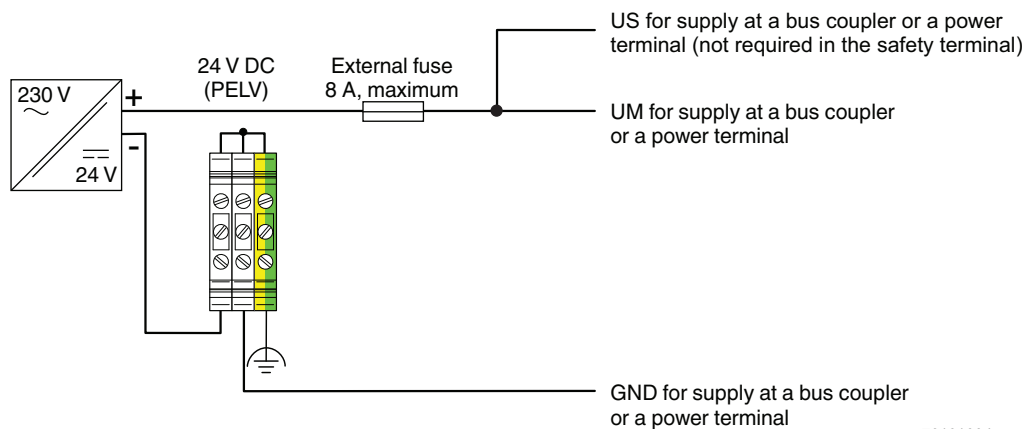

76191004

Figure 3-1 Supply  $U_M$  with connection to functional earth ground according to EN 60204-1



**WARNING: Loss of functional safety due to parasitic voltages**

Supply the supply voltages  $U_M$  and  $U_S$  at a bus coupler and/or a power terminal from the same power supply unit, so that the loads of IB IL 24 LPSDO 8-PAC are not affected by parasitic voltages in the event of an error.

**NOTE: Damage to module electronics in the event of surge voltage**

Do not use a DC distribution network.

DC distribution network according to IEC 61326-3-1:

A DC distribution network is a DC supply network, which supplies a complete industrial hall with DC voltage and to which any device can be connected. A typical system or machine distribution is not a DC distribution network. For devices that are provided for a typical system or machine distribution, the DC connections are viewed and tested as I/O signals according to IEC 61326-3-1.

### 3.4 Terminal point assignment

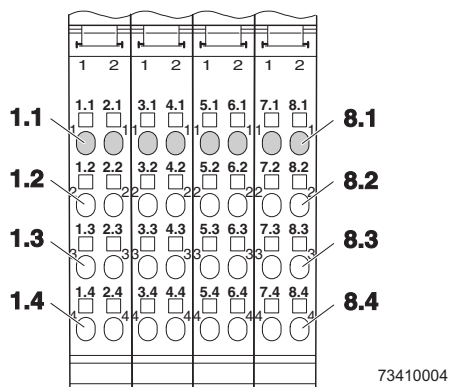

Figure 3-2 Terminal point assignment

The Inline connectors are supplied with the module. They are keyed and labeled accordingly for connection to prevent polarity reversal. If other connectors are used according to the ordering data, they must also be keyed.



Only use the connectors supplied with the module or connectors that are approved as replacement items (see "Ordering data: Accessories" on page 10-7).

The following applies for the tables below:

- All outputs are safe digital outputs.
- 0 V (GND): Common ground for outputs
- FE: Common functional earth ground

Table 3-1 Terminal point assignment for connector 1

Terminal point	Signal	Channel assignment	LED
1.1	OUT0_Ch1	Output 0, channel 1	0.1
2.1	OUT0_Ch2	Output 0, channel 2	0.2
1.2	Not used		
2.2	Not used		
1.3	0 V (GND)	Channel 1 and channel 2	
2.3	0 V (GND)	Channel 1 and channel 2	
1.4	FE		
2.4	FE		

## Inline potential and data routing, and Inline connectors

Table 3-2 Terminal point assignment for connector 2

Terminal point	Signal	Channel assignment	LED
3.1	OUT1_Ch1	Output 1, channel 1	1.1
4.1	OUT1_Ch2	Output 1, channel 2	1.2
3.2	Not used		
4.2	Not used		
3.3	0 V (GND)	Channel 1 and channel 2	
4.3	0 V (GND)	Channel 1 and channel 2	
3.4	FE		
4.4	FE		

Table 3-3 Terminal point assignment for connector 3

Terminal point	Signal	Channel assignment	LED
5.1	OUT2_Ch1	Output 2, channel 1	2.1
6.1	OUT2_Ch2	Output 2, channel 2	2.2
5.2	Not used		
6.2	Not used		
5.3	0 V (GND)	Channel 1 and channel 2	
6.3	0 V (GND)	Channel 1 and channel 2	
5.4	FE		
6.4	FE		

Table 3-4 Terminal point assignment for connector 4

Terminal point	Signal	Channel assignment	LED
7.1	OUT3_Ch1	Output 3, channel 1	3.1
8.1	OUT3_Ch2	Output 3, channel 2	3.2
7.2	Not used		
8.2	Not used		
7.3	0 V (GND)	Channel 1 and channel 2	
8.3	0 V (GND)	Channel 1 and channel 2	
7.4	FE		
8.4	FE		

**WARNING: Loss of functional safety due to parasitic voltages**

Connect the ground of the actuator to the ground terminal point of the corresponding output on the Inline connector. An external ground may not be used.

## 4 Assembly, removal, and electrical installation

### 4.1 Assembly and removal

#### 4.1.1 Unpacking the module

The module is supplied in an ESD box together with a package slip with installation instructions. Please read the complete package slip carefully.

The module may only be installed and removed by qualified personnel.

**NOTE: Electrostatic discharge**

The safety module contains components that can be damaged or destroyed by electrostatic discharge. When handling the safety module, observe the necessary safety precautions against electrostatic discharge (ESD) according to EN 61340-5-1 and EN 61340-5-2.

#### 4.1.2 General

**WARNING: Unintentional machine startup**

Do not assemble or remove the module while the power is connected.

Before assembling or removing the module, disconnect the power to the module and the entire Inline station and ensure that it cannot be switched on again.

Make sure the entire station is reassembled before switching the power back on.

Observe the diagnostic indicators and any diagnostic messages.

The system must only be started when neither the station nor the system can cause any damage.

The IB IL 24 LPSDO 8-PAC safety terminal is designed for use within an Inline station. Only use the safety terminal in the 24 V DC area of an Inline station.

For reliable operation, the safety terminal must be installed in housing protected from dust and humidity (IP54 or higher). In order to prevent manipulation, secure the housing (control cabinet/control box) against being opened by unauthorized persons.

All Inline terminals are mounted on 35 mm DIN rails.

Only connect the cables using the supplied Inline connectors or Inline connectors listed in the ordering data.

### 4.1.3 Setting the DIP switches

The module has a 2-pos. and a 10-pos. DIP switch.

The DIP switches are located on the left-hand side of the safety module.

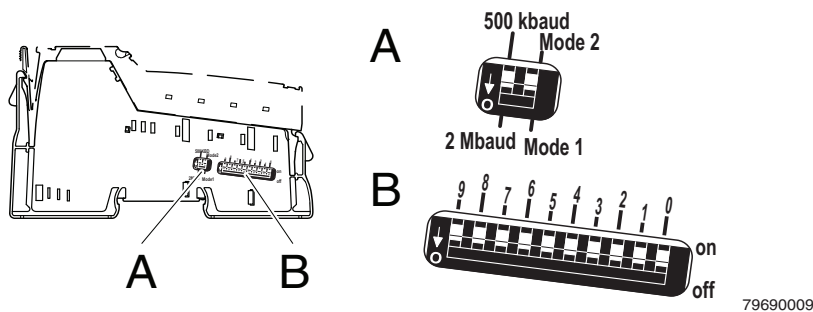

Figure 4-1 DIP switches

- A Switch for setting the transmission speed and the operating mode
- B Switch for setting the address

**2-pos. DIP switch:**

The transmission speed and the operating mode (Mode) are set via the 2-pos. DIP switch.

**Left switch:  
Transmission  
speed**

The transmission speed can be set to 500 kbaud or 2 Mbaud.  
The transmission speed is set to 2 Mbaud by default.



Only use devices with a uniform transmission speed within an Inline station (a local bus). A mixture of devices with different transmission speeds cannot be operated.

**Right switch:  
Mode**

Select the switch position according to the operating mode:

Table 4-1 Operating mode

Operating mode	Mode
SafetyBridge (16-word register length)	1
SafetyBridge multiplexer	1



Mode 2 is reserved at present.

**10-pos. DIP switch:  
Address**

The SafetyBridge address is set via the 10-pos. DIP switch.



**NOTE: Malfunction in the event of incorrect addressing**  
Make sure that in an overall system comprising the SafetyBridge system and any higher-level PROFIsafe system, the addresses (address within the SafetyBridge system and F-Address of the PROFIsafe system) are unique. Duplicate address assignment is not permitted.

## Assembly, removal, and electrical installation

Set the SafetyBridge address. The set SafetyBridge address is used to determine the island number of the terminal.

The DIP switch is set to  $3FF_{\text{hex}}$  by default. This address is not valid for a SafetyBridge system, therefore a valid address must be set.



### NOTE: Malfunction during mixed operation

During simultaneous use of SafetyBridge V2 and SafetyBridge V3 on a controller, make sure that the island number of the SafetyBridge V3 system is  $\geq 8$ .

This should be checked during overall validation of the system.

Use switches 9 to 5 to set the island number.

An "island" always consists of the IB IL 24 LPSDO 8 V3-PAC and the satellites assigned to it.

### Overview of the switch positions

Table 4-2 Switch position for SafetyBridge V3

SafetyBridge V3									
Address switch									
Island number					Reserved				
9	8	7	6	5	4	3	2	1	0
					OFF	OFF	OFF	OFF	OFF
$1_{\text{dec}}$ to $31_{\text{dec}}$					$0_{\text{dec}}$				

Table 4-3 Switch position for SafetyBridge

SafetyBridge										
Mode switch	Address switch									
	Island number							Satellite number		
	9	8	7	6	5	4	3	2	1	0
Mode 1	off	off						0	0	0
			$1_{\text{dec}}$ to $31_{\text{dec}}$				$0_{\text{dec}}$			

Table 4-4 Switch position for SafetyBridge in multiplexer mode

SafetyBridge multiplexer mode										
Mode switch	Address switch									
	Island number							Satellite number		
	9	8	7	6	5	4	3	2	1	0
Mode 1	on	off						0	0	0
			$1_{\text{dec}}$ to $31_{\text{dec}}$				$0_{\text{dec}}$			

### Procedure

If the DIP switch settings have to be modified, proceed as follows:

- Use the switch to set the transmission speed to 500 kbaud or 2 Mbaud.
- Use the switch to set the operating mode to mode 1.

**IB IL 24 LPSDO 8-PAC**

---

- Set the address.



Set the DIP switches **before** assembling the module in the Inline station. The switches cannot be accessed when the safety terminal is installed in the Inline station.

#### 4.1.4 Assembly and removal of the safety module



For general information about mounting and removing Inline terminals, please refer to the IL SYS INST UM E user manual.

##### Assembly



- Set the DIP switches prior to assembly (see "Setting the DIP switches" on page 4-2). The DIP switches cannot be accessed when the safety module is installed in the Inline station.
- Observe a mounting distance of 30 mm above and 40 mm below the safety module. Shorter distances may inhibit proper handling during installation.

##### – Snap on base

- Disconnect the power to the station.
- Before snapping on the safety module, remove the inserted connectors from the safety terminal and the adjacent connector from the neighboring Inline terminal on the left. This prevents the potential routing knife contacts and the keyway/featherkey connections from being damaged.
- Hold the safety module perpendicular and snap it onto the DIN rail (7.5 mm in height).



Ensure that **all** featherkeys and keyways on adjacent terminals are **securely** interlocked.

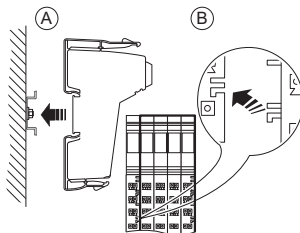

Figure 4-2 Snapping on the safety module base

- Check that all the snap-on mechanisms are securely snapped into place.
- Insert the connectors in the specified order (A, B).

##### – Insert connectors



Only use the connectors supplied with the module or connectors that are approved as replacement items (see "Ordering data: Accessories" on page 10-7).

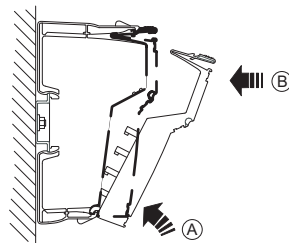

Figure 4-3 Inserting the connectors

## IB IL 24 LPSDO 8-PAC

---

### Removal

- Disconnect the power to the station.
- Before snapping on the safety module, remove the connectors from the safety module and the adjacent connector from the neighboring Inline terminal on the left.

#### – Remove connector

- Remove the connector by pressing the back shaft latching (A) and levering off the connector (B).

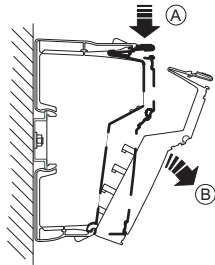

Figure 4-4 Removing the connector

#### – Remove base

- Release the base by pressing on the front and back snap-on mechanisms (A) and pull it out perpendicular to the DIN rail (B).

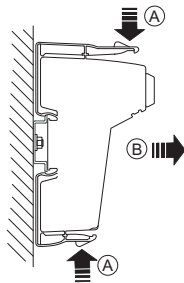

Figure 4-5 Removing the safety module base

## 4.2 Electrical installation



### **WARNING: Electric shock/unintentional machine startup**

Prior to electrical installation, disconnect the power to the system and make sure that it cannot be switched on again unintentionally.

Make sure installation has been completed before switching the power back on.

The system must only be started when the system cannot cause a hazard.

### 4.2.1 Electrical installation of the Inline station

Electrical installation of the Inline station includes the following:

- Connecting the bus system to the Inline station
- Connecting the supply voltages for the Inline station

Carry out electrical installation for the Inline station according to the IL SYS INST UM E user manual or the Inline system manual for your bus system. Please also observe the specifications in the documentation for the bus coupler used.

### 4.2.2 Electrical installation of the safety module



During installation, always observe the instructions in "Electrical safety" on page 1-3.

Take measures to prevent the incorrect connection, polarity reversal, and manipulation of connections.

The supply voltages are supplied at a bus coupler and/or a power terminal and are supplied to the safety module via the potential jumpers. Therefore the electrical installation of the safety module only involves connecting the actuators.

The actuators are connected via Inline connectors.

- Wire the connectors according to your application. For the terminal point assignment, please refer to "Terminal point assignment" on page 3-4.

For wiring, proceed as follows:

- Strip 8 mm off the cable.



Inline wiring is normally done without ferrules. However, it is possible to use ferrules. If using ferrules, make sure they are properly crimped.

- Push a screwdriver into the slot of the appropriate terminal point (Figure 4-6, detail 1), so that you can insert the wire into the spring opening.  
Phoenix Contact recommends using a SZF 1 - 0,6X3,5 screwdriver (Order No. 1204517; see Phoenix Contact "CLIPLINE" catalog).
- Insert the wire (Figure 4-6, detail 2). Remove the screwdriver from the opening. This clamps the wire.

**IB IL 24 LPSDO 8-PAC**

---

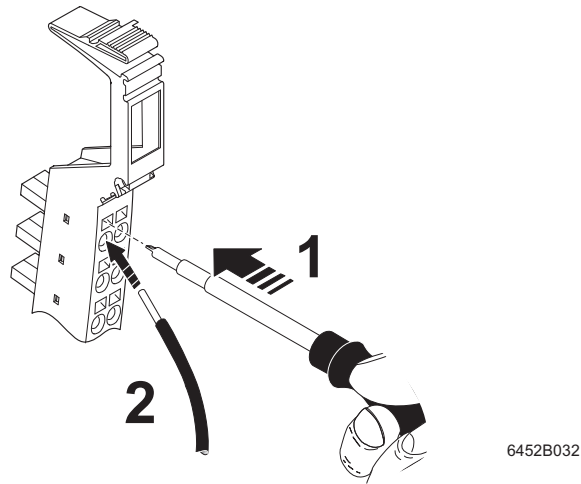

Figure 4-6 Connecting unshielded cables

- Insert the assembled connectors in the corresponding module slot (see "Terminal point assignment" on page 3-4).
- Label all connections to prevent connections to the Inline connectors being mixed up (see IL SYS INST UM E user manual).

## 5 Parameterization of the safety module

### 5.1 Parameterization of the safety module in a SafetyBridge system



For information about the configuration and parameterization of the SafetyBridge system, please refer to "Configuration and parameterization using the SAFECONF tool" on page A-21.

Parameterization includes the following:

- Specifying the SafetyBridge address
- Parameterization of outputs

#### SafetyBridge address

The SafetyBridge address is a unique ID for the safety module in the SafetyBridge structure. It is set in the configuration software.



For additional information about the SafetyBridge address, please refer to "Operating modes and setting the DIP switches in the SafetyBridge system" on page A-8 and "SafetyBridge address assignment" on page A-5.

Set this address via the DIP switches prior to assembly (see "Setting the DIP switches" on page 4-2).

#### Parameterization and configuration of the module

The parameterization and configuration determines the behavior of the module and thus has a considerable effect on the safety integrity level that can be achieved.

To parameterize and configure the module, the parameterization and configuration created in the parameterization tool must be written from the controller to the module (e.g., with a function block) on every power up or reset.



For information about downloading, please refer to "Downloading the configuration and parameter data record following power up" on page A-22.

The supply voltage must be present and the local bus must be in the RUN state when downloading.

The module cannot be operated if it is not parameterized. In this case, the FS LED flashes.

The module is ready to operate if the parameters for all outputs are valid and transmitted without errors. Valid output data is only written in this state. In any other state, every output is set to the safe state.

If errors are detected during parameterization, the parameterization data is not transmitted. The invalidity of the parameterization is indicated on the module by the flashing FS LED. In addition, errors are indicated at the controller. In this case, check and correct the settings.

## 5.2 Parameterization of the safe outputs

The individual outputs of a safety module can be parameterized differently and thus achieve different safety integrity levels (SIL, SIL CL, Cat., PL).

### Two-channel

If the outputs are operated via two channels, the following fixed assignment applies:

- OUT0\_Ch1 to OUT0\_Ch2
- OUT1\_Ch1 to OUT1\_Ch2
- OUT2\_Ch1 to OUT2\_Ch2
- OUT3\_Ch1 to OUT3\_Ch2

### Single-channel

If two-channel operation in the external wiring of the outputs is not required, the outputs can be parameterized in such a way that they operate independently of one another (single-channel).

### Parameterization

All safe outputs must be parameterized individually. The parameterization options are described in Table 5-1.

Table 5-1 Parameterization of outputs

Parameterization	Value range	Remark
	OUT0 - OUT3	
Assignment	Not used Used	The unused outputs are disabled. However, the monitoring of these outputs remains active.
Output	Single-channel Two-channel	In two-channel operation, the assignment of the outputs to one another is specified and cannot be parameterized.
Switch-off delay for stop category 1	Disabled Enabled	Disabled (default): No switch-off delay Enabled: The outputs are switched off once the parameterized switch-off delay has elapsed.  Please observe the notes below this table.
Switch-off delay for stop category 1	1 to 63	Time conversion according to the parameterization of the "Value range of switch-off delay for stop category 1" parameter. Permissible value range: OUT0 to OUT3: 150 ms to 630 s Accuracy: -5% of the parameterized value - 2 ms/+0 ms  Please observe the notes below this table.

## Parameterization of the safety module

Table 5-1 Parameterization of outputs (continued)

Parameterization	Value range	Remark
	OUT0 - OUT3	
Value range of switch-off delay for stop category 1	Value * 10 in ms Value * 100 in ms Value in s Value * 10 in s	Value range/unit for the parameterization of the "Switch-off delay for stop category 1" parameter. Please observe the notes below this table.
Test pulses (output disabled) (in software: test impulses (output switched off))	Disabled Enabled	Activation and deactivation of test pulses. For these test pulses, the output drivers that are switched off are temporarily switched on for test purposes. See note below this table.
Enable	Disabled Enabled	Disabled (default): The corresponding safe output is operated exclusively according to the safety logic. Enabled: Enable is active; the safe output data is output after being ANDed with the "Data_LPSDO" process data item (see Figure A-4 on page A-13).

## Test pulses

**Note on test pulses**

If the test pulses are disabled, cross circuits and short circuits cannot be detected.  
Regardless of the parameterization selected under "Test impulses (output switched off)", the outputs parameterized as "Not used" are tested by test pulses.  
Please also observe "Requirements for controlled devices/actuators" on page 2-5 and "Connection examples for safe outputs" on page 6-1.

**Switch-off delay for stop category 1**

The **switch-off delay for stop category 1** is calculated from the "Switch-off delay for stop category 1" and "Value range of switch-off delay for stop category 1" parameters.

Switch-off delay for stop category 1 =  
Switch-off delay for stop category 1 \*  
Value range of switch-off delay for stop category 1



If the switch-off delay for stop category 1 is parameterized with a value less than 150 ms, this value is rejected as a parameterization error (error code 028x<sub>hex</sub>).

**Two-channel parameterization**

Please note the following for two-channel parameterization:

Ensure that the values for the switch-off delay for stop category 1 are the same for both channels. This means that the time must have the same value and the same value range.

### 5.3 Behavior of the outputs in the event of enabled switch-off delay for stop category 1

Depending on the event that causes the outputs to be switched off, and on the parameterization of the switch-off delay, the time until the outputs are actually switched off can vary.

Table 5-2 Disconnection of the outputs according to the trigger event and the parameterization

Disconnection of outputs	Influence of parameterized switch-off delay	Disconnection of outputs
– By the controller	Yes	Once the parameterized switch-off delay has elapsed
– After a bus error	Yes	Once the parameterized switch-off delay has elapsed
– After a short circuit, cross circuit, failure of the supply voltage or hardware fault	No	Immediately (only stop category 0)
– After time monitoring has been exceeded (watchdog time; $F_{WD\_Time}$ ) (e.g., in the event of faulty bus connection)	Yes	Once the parameterized switch-off delay has elapsed



**WARNING: Delayed shutdown when using stop category 1**

**For stop category 1 please take into consideration the following:**

- The guaranteed shutdown time  $t_G$  is extended by the parameterized switch-off delay.
- In the event of an error (excluding bus errors) the affected outputs are switched off immediately (without delay). In this case, only stop category 0 is supported.

For the switch-off operation, please take into consideration the following:

- The switch-off operation can be interrupted by switching the output on again.
- If the parameterization of the module is modified, the modified parameterization does not take effect until all the outputs have been switched off.  
If the parameterization is modified before the switch-off operation is complete, diagnostic message 02F2<sub>hex</sub> is generated.
- Carry out a validation every time the parameterization is modified.
- Please note that when the parameterization is modified, this can result in delayed startup due to the switch-off delay time.

## 6 Connection examples for safe outputs

### 6.1 Explanation of the examples

Depending on the type of wiring, the outputs of a module can achieve different safety integrity levels (SIL, SIL CL, Cat., PL) at the same time (as long as the settings do not contradict one another).

The following examples only describe the options for the electrical connection of controlled devices/actuators to the safe outputs.

Should you have any questions regarding applications to be implemented, please contact the Phoenix Contact safety hotline (see "Safety hotline" on page 1-8).

The following are specified for each example:

- **Basic specifications**  
The main data for the example is specified in the table.
- **Device diagnostics and behavior of the module in the event of an error**  
Diagnostic capability depends on the parameterization.  
If a message is transmitted to the controller in the event of an error, the message is specified in the tables. For information about the relevant error code, possible remedies, and information about whether acknowledgment is required, please refer to "Errors: Messages and removal" on page 8-1.
- **Typical parameterization**  
The table illustrates an example of all the parameters for specified assignment.

Key for all tables in this section:

Table 6-1 "Device diagnostics and behavior of the module in the event of an error" tables

Representation	Meaning
SF	Safety function
OUTx	OUT1 or OUT2 LED; diagnostic message for each output

Table 6-2 Parameterization tables

Representation	Meaning
<b>Bold</b>	Mandatory setting
Normal	Typical setting, another setting is possible depending on the application
–	Not evaluated

Errors (cross circuits, short circuits), which can be prevented by correct installation (e.g., protected cable installation, isolated cable installation, double insulation, use of ferrules) are not described in the following tables.

Therefore, for example, only errors between outputs, which are on the same connector, are described. For example, in the event of correct installation, cross circuits with outputs of other connectors cannot occur.



For all examples, please also observe the measures specified in the individual tables, which must be taken to achieve the specified SIL/SIL CL/Cat./PL and all measures according to standards EN 61508, EN 62061, EN 954-1, and EN ISO 13849-1 to achieve the specified SIL/SIL CL/Cat./PL.



**WARNING: Disregarding this warning may lead to the loss of the safety function**

An external voltage may not be supplied in an output (e.g., via cross circuits). These errors can adversely affect the operation of the module (or even destroy the module) and thus result in the loss of the safety function. Therefore, these errors must be prevented. Install the connection cables for connecting the actuators so that they are protected against cross circuits.

Please observe the load capacity of the outputs according to the technical data in "Safe digital outputs" on page 2-4.

## 6.2 Notes on the protective circuit for external relays/contactors (free running circuit)

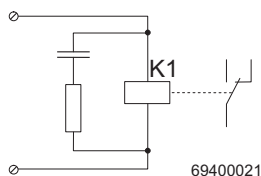

Figure 6-1 Example of the free running circuit for an external relay



- Limit the voltage induced on circuit interruption to <math>< -15\text{ V}</math> (e.g., with RC elements, suppressor diodes or varistors).
- Please note that the free running circuit affects the fall time and the service life of the contactor.
- Please observe the specifications of the relay manufacturer when sizing the relay protective circuit.

### 6.3 Measures required to achieve a specific safety integrity level

The safety integrity level (SIL, SIL CL, performance level, and category) that can be achieved is specified for each connection example.



Please also refer to "Achievable safety depending on the modules used" on page A-27.

#### SIL/SIL CL



In order to determine the probability of failure according to EN 61508 (SIL) and EN 62061 (SIL CL), use the relevant standard.

When the SIL/SIL CL is specified, the module takes up 1% of the specified SIL/SIL CL.

Table 6-3 PFD and PFH depending on the SIL/SIL CL

	PFD	PFH
SIL 2/SIL CL 2	1% of $10^{-2}$	1% of $10^{-6}$
SIL 3/SIL CL 3	1% of $10^{-3}$	1% of $10^{-7}$

#### Performance level



Use standard EN ISO 13849-1 to determine the performance level.

#### Category

In order to actually achieve the specified category, the required measures listed below must be implemented.

##### Cat. 2

- Use proven and basic safety principles according to EN ISO 13849-2.
- Use appropriately qualified actuators (see "Requirements for controlled devices/actuators" on page 2-5).
- Please note that mechanical failure of the switching device can result in the loss of the safety function.
- Prevent the welding of contacts on the connected contactors or safety relays with appropriate protection against overcurrent and surge voltage.
- Please note that **a single** error can result in the loss of the safety function between tests.
- Ensure that the external wiring is tested by the machine control system on machine startup and at suitable intervals. This test must detect the loss of the safety function.
- In the event of an error, either safe disconnection must be implemented or a warning (optical and/or audible) must be generated depending on the application.

**IB IL 24 LPSDO 8-PAC**

---

**Cat. 3**

- Use proven and basic safety principles according to EN ISO 13849-2.
- Use appropriately qualified actuators (see "Requirements for controlled devices/actuators" on page 2-5).
- Please note that mechanical failure of the switching device can result in the loss of the safety function.
- Prevent the welding of contacts on the connected contactors or safety relays with appropriate protection against overcurrent and surge voltage.
- All errors that cannot be detected can result in the loss of the safety function. Take appropriate measures to prevent such errors. Suitable measures include, for example, protected cable installation or double insulation. Please note the information in the following tables.
- Please take into consideration errors with a common cause.
- Ensure that **a single** error does not result in the loss of the safety function.

**Cat. 4**

- Use proven and basic safety principles according to EN ISO 13849-2.
- Use appropriately qualified actuators (see "Requirements for controlled devices/actuators" on page 2-5).
- Please note that mechanical failure of the switching device can result in the loss of the safety function.
- Prevent the welding of contacts on the connected contactors or safety relays with appropriate protection against overcurrent and surge voltage.
- An accumulation of errors must not result in the loss of the safety function. Following the third error, evaluation can be aborted if the probability of further errors occurring is low.
- All errors that cannot be detected can result in the loss of the safety function. Take appropriate measures to prevent such errors. Suitable measures include, for example, protected cable installation or double insulation. Please note the information in the following tables.
- Please take into consideration errors with a common cause.

### 6.4 Single-channel assignment of safe outputs

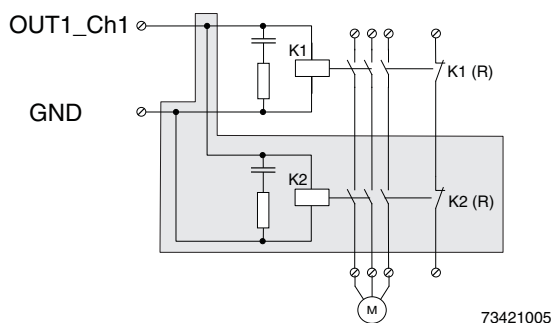

Figure 6-2 Single-channel assignment of outputs



- In order to achieve Cat. 3 or PL d with single-channel assignment of the outputs, a two-channel actuator must be used. The two-channel operation of the actuator with the corresponding connection is represented on a gray background.
- The failure detection time is 20 ms. This means that high pulses of this width can occur in the event of an error. If the application responds to these pulses, use the two-channel assignment of the outputs.

K1 (R) and K2 (R) represent the positively driven N/C contacts for monitoring the state of the relay (readback contacts). Connect these contacts via safe digital inputs. Evaluate the readback and thus the state of the switching elements in the safety logic.



**WARNING: Loss of safety function**

Connect the actuator ground directly to terminal point GND of the safety module. An external ground may not be used.

**Basic specifications**

Actuator	Single-channel	Two-channel
Achievable SIL/SIL CL/Cat./PL	SIL 2/SIL CL 2/Cat. 2/PL c	SIL 2/SIL CL 2/Cat. 3/PL d



**WARNING: Loss of electrical and functional safety**

- To achieve the specified safety integrity level, please refer to "Measures required to achieve a specific safety integrity level" on page 6-3.
- Please note that in order to achieve the specified PL, the actuator must have a medium level of diagnostic coverage (90% to 99%) and medium MTTFd. A high level of diagnostic coverage (> 99%) is recommended for the application according to PL d.
- To achieve Cat. 3 and PL d the test pulses must be enabled.
- Use actuators that can achieve the required safety integrity level.
- Evaluate the readback contacts to achieve the corresponding safety integrity level.

## IB IL 24 LPSDO 8-PAC



Enable the test pulses to improve device diagnostics.

If the test pulses for the actuator are faulty, they can be disabled. In this case, test the switching capability of the outputs at regular intervals.

### Device diagnostics and behavior of the module in the event of an error

Table 6-4 Single-channel: Test pulses enabled

Error type	Detection	Diagnostics	Loss of SF	Remark
<b>Error in the actuator</b>				
Despite being disabled, the actuator does not switch to the safe state (e.g., a contact will not open)	No	None	Yes	Detect errors using external monitoring. Please take into consideration all the possible errors for the actuator used. <b>Test the shutdown capability of the actuator at regular intervals. If necessary, use a two-channel actuator.</b>
Actuator cannot be enabled (e.g., interrupt)	No	None	No	Detect errors using external monitoring. Please take into consideration all the possible errors for the actuator used. <b>Ensure that this error does not result in delayed system startup.</b>
Other errors (depending on the actuator)				<b>Please take into consideration all possible errors that can occur in the actuator.</b>
<b>Error in the wiring</b>				
<b>Interrupt</b>				
Cable interrupt between output and actuator or between actuator and ground	No	None	No	Detect errors using external monitoring. Please take into consideration all the possible errors for the actuator used. <b>Ensure that this error does not result in delayed system startup.</b>
<b>Cross circuit</b>				
Output to output	Yes	All LEDs OUT: Red ON	Yes	When the outputs are disabled, a cross circuit between the outputs is only detected if the test pulses are enabled. If an error is detected, the module disables all its outputs.
<b>Short circuit</b>				
Output to ground or output to FE	Yes	Short circuit or overload, OUTx	No	The error is detected in the ON state. The output is disabled (safe state). The module cannot be switched on again with an edge from "0" to "1" until the error has been removed and acknowledged.  <div style="border: 1px solid black; padding: 5px; display: inline-block;">  <p><b>WARNING: Unexpected machine startup</b> An "operator acknowledgment" leads to a positive edge and can thus result in the outputs being re-enabled.</p> </div>

---

**Connection examples for safe outputs**
**Typical parameterization**

Parameterization	Parameterized as	Remark
Assignment	<b>Used</b>	
Output	<b>Single-channel</b>	
Switch-off delay for stop category 1	Enabled	Or disabled
Switch-off delay for stop category 1	30	Application-specific
Value range of switch-off delay for stop category 1	Value in s	Application-specific
Test pulses (output disabled) (in software: test impulses (output switched off))	Enabled	Or disabled

According to the "Value range of switch-off delay for stop category 1" and "Switch-off delay for stop category 1" parameters, in this example, the switch-off delay is  $30 \times 1 \text{ s} = 30 \text{ s}$ .

## 6.5 Two-channel assignment of safe outputs

For two-channel assignment of the safe outputs, two adjacent outputs are always used. This assignment is fixed and cannot be parameterized (see "Two-channel" on page 5-2).

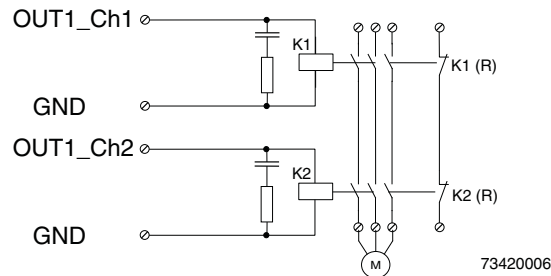

Figure 6-3 Two-channel assignment of outputs

K1 (R) and K2 (R) represent the positively driven N/C contacts for monitoring the state of the relay (readback contacts). Connect these contacts via safe digital inputs. Evaluate the readback and thus the state of the switching elements in the safety logic.



### WARNING: Loss of safety function

- Connect the actuator ground directly to terminal point GND of the safety module. An external ground may not be used.
- The failure detection time is 20 ms. This means that high pulses of this width can occur at the faulty output (channel) in the event of an error. The two-channel assignment means that this does not result in a hazardous state.

### Basic specifications

<b>Actuator</b>	Two-channel
<b>Achievable SIL/SIL CL/Cat./PL</b>	SIL 3/SIL CL 3/Cat. 4/PL e



### WARNING: Loss of electrical and functional safety

- To achieve the specified safety integrity level, please refer to "Measures required to achieve a specific safety integrity level" on page 6-3.
- Please note that in order to achieve the specified PL, the actuator must have a medium level of diagnostic coverage (90% to 99%) and medium MTTFd. A high level of diagnostic coverage (> 99%) is recommended for the application according to PL d.
- Use actuators that can achieve the required safety integrity level.
- Evaluate the readback contacts to achieve Cat. 3 or Cat. 4.
- If the test pulses are disabled:  
Test the outputs and external wiring by enabling the outputs at regular intervals. The time between two tests must not exceed eight hours.



Enable the test pulses to improve device diagnostics.  
 If the test pulses for the actuator are faulty, they can be disabled. In this case, test the switching capability of the outputs at regular intervals.

**Device diagnostics and behavior of the module in the event of an error**

Table 6-5 Two-channel

Error type	Detection	Diagnostics	Loss of SF	Remark
<b>Error in the actuator</b>				
Despite being disabled, a switching element of the two-channel actuator does not switch to the safe state (e.g., a contact will not open)	No	None	No	No loss of the safety function as the second switching element of the two-channel actuator can be disabled. Detect errors using external monitoring. <b>Implement a restart inhibit in the event of this error.</b> Please take into consideration all the possible errors for the actuator used. <b>Test the shutdown capability of the actuator at regular intervals.</b>
Actuator cannot be enabled (e.g., interrupt)	No	None	No	Detect errors using external monitoring. Please take into consideration all the possible errors for the actuator used. <b>Ensure that this error does not result in delayed system startup.</b>
Other errors (depending on the actuator)				<b>Please take into consideration all possible errors that can occur in the actuator.</b>
<b>Error in the wiring</b>				
<b>Interrupt</b>				
Cable interrupt between output and actuator or between actuator and ground	No	None	No	Detect errors using external monitoring. Please take into consideration all the possible errors for the actuator used. <b>Ensure that this error does not result in delayed system startup.</b>
<b>Cross circuit</b>				
Output to output	Yes (conditional)	All LEDs OUT: Red ON	No	When the outputs are disabled, a cross circuit between the outputs is only detected if the test pulses are enabled. If an error is detected, the module disables all its outputs. <b>If the test pulses have been disabled, test the circuit and the external wiring at regular intervals by enabling the outputs.</b>
<b>Short circuit</b>				
Output to ground or output to FE	Yes	Short circuit or overload, OUTx	No	The error is detected in the ON state. The output is disabled (safe state). The module cannot be switched on again with an edge from "0" to "1" until the error has been removed and acknowledged. <div style="border: 1px solid black; padding: 5px; display: inline-block;"> <b>WARNING: Unexpected machine startup</b>                      An "operator acknowledgment" leads to a positive edge and can thus result in the outputs being re-enabled.                 </div>

## IB IL 24 LPSDO 8-PAC

## Typical parameterization

Parameterization	Parameterized as		Remark
	Channel 1	Channel 2	
Assignment	<b>Used</b>	<b>Used</b>	
Output	<b>Two-channel</b>	<b>Two-channel</b>	
Switch-off delay for stop category 1	Enabled	Enabled	Or disabled
Switch-off delay for stop category 1	30	30	Application-specific
Value range of switch-off delay for stop category 1	Value in s	Value in s	Application-specific
Test pulses (output disabled) (in software: test impulses (output switched off))	<b>Enabled</b>	<b>Enabled</b>	

According to the "Value range of switch-off delay for stop category 1" and "Switch-off delay for stop category 1" parameters, in this example, the switch-off delay is  $30 \times 1 \text{ s} = 30 \text{ s}$ .

## 7 Startup and validation

### 7.1 Initial startup

Requirement: Parameterization and configuration have already been carried out

Table 7-1 Steps for parameterization and configuration (via SAFECONF)

Step	Relevant section and literature
<b>Requirement for startup: Parameterization and configuration have been carried out</b>	
Carry out the necessary parameterization.	"Parameterization of the safety module" on page 5-1
Carry out the necessary parameterization for the remote island modules.	User manuals for the modules used
Configure the safety function.	User manuals for the function blocks used
Configure the enable.	"Enable principle" on page A-18

To start up, proceed as described in Table 7-2.

Table 7-2 Steps for startup

Step	Relevant section and literature
Set the transmission speed and the operating mode.	"Setting the DIP switches" on page 4-2
Set the address.	"Setting the DIP switches" on page 4-2
Install the safety module within the Inline station.	"Assembly, removal, and electrical installation" on page 4-1
Connect the bus system and supply voltage cables to the Inline station.	IL SYS INST UM E user manual or documentation for the bus coupler
Wire the outputs according to your application.	"Assembly, removal, and electrical installation" on page 4-1 "Inline potential and data routing, and Inline connectors" on page 3-1 User manuals for the function blocks used
Before applying the operating voltage: <ul style="list-style-type: none"> <li>– Ensure that there are no wiring errors (e.g., cross circuit or short circuit) or grounding errors by testing with a multimeter.</li> <li>– Check whether the ground connection is safe.</li> </ul>	
Connect the required voltages to the Inline station.	IL SYS INST UM E user manual or documentation for the bus coupler
Connect the required voltages ( $U_M$ ) to the safety module.	"Supply voltage $U_M$ " on page 3-2

**IB IL 24 LPSDO 8-PAC**

Table 7-2 Steps for startup (continued)

<b>Step</b>	<b>Relevant section and literature</b>
Once the operating voltage has been applied: <ul style="list-style-type: none"> <li data-bbox="159 373 786 432">– If possible, measure the wave form of the voltages to ensure that there are no deviations.</li> <li data-bbox="159 436 786 554">– Measure the output voltages on the module, as well as the supply voltages, which supply the connected loads (e.g., motor) to ensure that they are in the permissible range.</li> <li data-bbox="159 558 786 676">– Use the LEDs on the devices to check that the module starts up without any errors (there must be no red LEDs permanently on; the FS LED flashes because the device is not parameterized).</li> </ul>	
Check the assembly and installation.	Checklist "Assembly, removal, and electrical installation" on page 4-1
Implement the data flow between the standard control system and the safety modules and between the safety modules themselves.	"Implementation of data flow between the standard control system and the safety modules" on page A-18
Download the parameterization and configuration data from the standard control system to the safety modules.	"Downloading the configuration and parameter data record following power up" on page A-22
Perform a function test and validation. Check whether the safety function responds as planned during configuration and parameterization.	Checklist "Validation" on page B-12

When connecting the supply voltages, use the diagnostic and status indicators to check whether the module has started up correctly or whether any errors are indicated. For instructions on how to proceed in the event of an error, please refer to "Errors: Messages and removal" on page 8-1.

## 7.2 Restart after replacing a safety module

### 7.2.1 Replacing a safety module

**WARNING: Unintentional machine startup**

Do not assemble or remove the module while the power is connected.

Before assembling or removing the module, disconnect the power to the module and the entire Inline station and ensure that it cannot be switched on again.

Make sure the entire station is reassembled before switching the power back on.

Observe the diagnostic indicators and any diagnostic messages.

The system must only be started when neither the station nor the system can cause any damage.

If replacing a module, proceed as described for assembly and removal (see "Assembly, removal, and electrical installation" on page 4-1).

Ensure that the new safety module is mounted at the correct position in the local bus. The new module must meet the following requirements:

- Same device type
- Same or later version

Carry out a validation and perform a function test after replacing the module

### 7.2.2 Restart

Once the safety module has been replaced, proceed as described for initial startup (see "Initial startup" on page 7-1).

The parameterization of the previous module remains the same and is transmitted to the new module when the system is started.

Plug the Inline connectors into the correct connections.

Carry out a validation and perform a function test after replacing the module

## 7.3 Validation

Carry out a safety validation every time you make a safety-related modification to the SafetyBridge system.

When validating your individual EUC, check the assignment of the actuator connections.

Determine whether:

- The correct safe actuators are connected to the safety module
- The safety module has been parameterized correctly
- The signals used in your safety logic have been linked to the safe actuators correctly

Perform a function test and error simulation.

Please observe the checklist "Validation" on page B-12 during validation.

## 8 Errors: Messages and removal

Depending on the error type, errors that are diagnosed are displayed via the local diagnostic indicators and/or transmitted to the controller as diagnostic messages.

The tables below provide an overview of the diagnosed errors, their causes, effects, and possible measures for error removal.

For every error that occurs, the cause of the error must first be removed. If necessary, the error is then acknowledged. Errors that must be acknowledged are indicated in the "Acknowledgment" column in the tables below.



If error codes are indicated by the system, which do not appear in the tables below, please contact Phoenix Contact.

### Error removal

To remove the cause of an error, please proceed as described in the "Remedy" column in the tables below.

### Error acknowledgment

Instructions on how to acknowledge an error can be found in "Acknowledging an error" on page 8-9.



#### **WARNING: Unexpected machine startup**

An "operator acknowledgment" leads to a positive edge and can thus result in the outputs being re-enabled.

## IB IL 24 LPSDO 8-PAC

### Notes on the tables below

The error code of a diagnostic message is comprised of the code for the error cause and the code for the error location.

### Structure of the error code

Error code	
Code for error cause	Code for error location
E.g.: 003	x

### Error code

The error code is specified in Table 8-1 and onwards.



The code, which is represented in bits 10 ... 0 of the diagnostic register of the IB IL 24 LPSDO 8-PAC, is specified in the tables. The specified error code can be obtained by masking out the diagnostic register (see "Dev-Diag-LPSDO (diagnostic LPSDO)" on page A-15).

### Error location

In the error code specified, "x" specifies the location of the error. The value range for "x" is specified in the relevant row of the table.

For some errors a single channel is specified as the error location (e.g., OUT0\_Ch1). Some errors only occur for outputs parameterized for two-channel operation. Here, the channel pair is specified as the error location (e.g., OUT0\_Ch1&2).

### Example:

Safe output errors (Table 8-1)

Error cause	Error code (hex)
Short circuit or overload	003x
x = 0 ... 3: OUT0_Ch1 ... OUT3_Ch1; x = 7 ... A: OUT0_Ch2 ... OUT3_Ch2	

**003x** Short circuit or overload

**003x** Error location

This means, for example:

0032 Cross circuit at OUT2\_Ch1 (output 2 channel 1)

003A Cross circuit at OUT3\_Ch2 (output 3 channel 2)

### LED

The "LED" column specifies which local diagnostic LEDs indicate the error.

### Acknowledgment

To remove the error, evaluate the PUR and OAR bits in the diagnostic register of the IB IL 24 LPSDO 8-PAC (see "Dev-Diag-LPSDO (diagnostic LPSDO)" on page A-15). These specify whether a power up is expected or whether an acknowledgment is required.

Errors that must be acknowledged are indicated with "Yes" in the "Acknowledgment" column. Special conditions for re-enabling an output or the module are specified in brackets [e.g., Yes (1)] in the "Acknowledgment" column and explained below the relevant table.



To acknowledge the error messages of remote modules, refer to "Acknowledgment of error messages for remote modules (satellites)" on page A-21.

## 8.1 Safe digital output errors

Table 8-1 Safe digital output errors

Error cause	Error code (hex)	LED	Remark	Effect	Remedy	Acknowledgment
<b>Hardware fault</b> x = 0 ... 3: OUT0_Ch1 ... OUT3_Ch1; x = 7 ... A: OUT0_Ch2 ... OUT3_Ch2	<b>001x</b>	All OUT: Red ON	The indicated output cannot be disabled	All module outputs are in the safe state	Power up with error-free selftest Replacement	Yes (1)
<b>Short circuit or overload</b> x = 0 ... 3: OUT0_Ch1 ... OUT3_Ch1; x = 7 ... A: OUT0_Ch2 ... OUT3_Ch2	<b>003x</b>	OUTy: Red ON		Affected output is in the safe state	Check actuator Check connector and cabling Check free running circuit at the contactor	Yes (2)
<b>Error at the output or short circuit during the test</b> x = 0 ... 3: OUT0_Ch1 ... OUT3_Ch1; x = 7 ... A: OUT0_Ch2 ... OUT3_Ch2	<b>005x</b>	All OUT: Red ON	Pulse test (brief activation) at the output failed	All module outputs are in the safe state	Power up with error-free selftest Replacement	Yes (1)
<b>Error at the output during the test</b> x = 0 ... 3: OUT0_Ch1 ... OUT3_Ch1; x = 7 ... A: OUT0_Ch2 ... OUT3_Ch2	<b>006x</b>	All OUT: Red ON	Pulse test (brief deactivation) at the output failed	All module outputs are in the safe state	Power up with error-free selftest Replacement	Yes (1)
<b>Hardware fault</b>	<b>0091</b>	All OUT: Red ON	Detected by internal tests.	All module outputs are in the safe state	Power up with error-free selftest Replacement	Yes (1)
<b>Cross circuit at the indicated output</b> x = 0 ... 3: OUT0_Ch1 ... OUT3_Ch1; x = 7 ... A: OUT0_Ch2 ... OUT3_Ch2	<b>00Ax</b>	All OUT: Red ON	Cross circuit with another output or with an external signal	All module outputs are in the safe state	Remove error Power up with error-free selftest	Yes (1)

Acknowledge all errors that are present. Only then can the outputs be re-enabled.

### Acknowledgment: Yes (1)

Acknowledging the diagnostic message deletes the message. The module can only be restarted following power up and error-free selftest.

## IB IL 24 LPSDO 8-PAC

**Acknowledgment: Yes (2)**

Acknowledging the diagnostic message deletes the message and enables a restart. Following successful acknowledgment, the module also expects a positive edge from the application for the output.

**WARNING: Unexpected machine startup**

An operator acknowledgment leads to a positive edge and can thus result in the outputs being re-enabled.

## 8.2 Supply voltage errors

Table 8-2 Supply voltage  $U_M$  errors

Error cause	Error code (hex)	LED	Remark	Effect	Remedy	Acknowledgment
Undervoltage $U_M$	01F0	UM flashing	$U_M$ below the permissible voltage range	All module outputs are in the safe state	Check supply voltage level and correct Check supply line length and load	Yes (1)

**Acknowledgment: Yes (1)**

Acknowledging the diagnostic message deletes the message and activates the outputs.

**Undervoltage at  $U_M$** 

Supply voltage  $U_M$  is measured. If  $U_M < 17\text{ V}$ , a diagnostic message is generated.

### 8.3 Parameterization errors

Table 8-3 Parameterization errors

Error cause	Error code (hex)	LED	Remark	Effect	Remedy	Acknowledgment
<b>Incorrect parameterization</b>	See Table 8-4	FS (flashing)	Each output is parameterized individually.	Module is in the safe state.	Check parameterization and correct.	–

In order to determine what type of parameterization error has occurred, use the corresponding software to access the controller online and read the error (see "Descriptions of the registers" on page A-14).

Proceed as follows, e.g., in the SafetyBridge system:

- The diagnostic LEDs indicate that an error has occurred.
- Go online to the higher-level standard control system.  
For each module of the SafetyBridge island, a diagnostic register is mapped to the process image of the IB IL 24 LPSDO 8-PAC (see "Descriptions of the registers" on page A-14).  
From this, determine the module of the safety island in which an error has occurred.
- Evaluate the specified error code.

Table 8-4 Parameterization errors

Error code		Short description	Remedy
(hex)	(dec)		
<b>023x</b> x = 0 ... 3: OUT0_Ch1&2 ... OUT3_Ch1&2	<b>560:</b> OUT0_Ch1&2 : <b>563:</b> OUT3_Ch1&2	The parameterization of two related outputs does not correspond to the two-channel setting.	Correct value and resend parameter data to the module.
<b>028x</b> x = 0 ... 3: OUT0_Ch1 ... OUT3_Ch1; x = 7 ... A: OUT0_Ch2 ... OUT3_Ch2	<b>640:</b> OUT0_Ch1 : <b>643:</b> OUT3_Ch1; <b>647:</b> OUT0_Ch2 : <b>650:</b> OUT3_Ch2	The parameterized switch-off delay time for the output is outside the permissible value range.	Correct value and resend parameter data to the module.
<b>029x</b> x = 0 ... 3: OUT0_Ch1&2 ... OUT3_Ch1&2	<b>656:</b> OUT0_Ch1&2 : <b>659:</b> OUT3_Ch1&2	For outputs parameterized for two-channel operation, the same settings were not assigned for the switch-off delay.	Correct setting and resend parameter data to the module.
<b>02Bx</b> x = 0 ... 3: OUT0_Ch1&2 ... OUT3_Ch1&2	<b>688:</b> OUT0_Ch1&2 : <b>691:</b> OUT3_Ch1&2	For outputs parameterized for two-channel operation, the same settings were not assigned for enabling.	Correct setting and resend parameter data to the module.
<b>02F2</b>	<b>754</b>	At least one output with parameterized switch-off delay is still performing a switch-off operation.	Wait until the switch-off operation is complete and resend parameter data to the module.

## 8.4 General errors

Table 8-5 General errors

Error cause	Error code (hex)	LED	Remark	Effect	Remedy	Acknowledgment
Device temperature at critical value	01F2			Immediate shutdown. Further temperature increase causes the module to switch to the safe state.	Check and adapt: <ul style="list-style-type: none"> <li>– Ambient conditions</li> <li>– Derating</li> <li>– Output loads</li> <li>– Switching frequency</li> </ul>	Yes (1)
Hardware fault		FS ON	Error in the logic area	Module is in the safe state	Replacement	

**Acknowledgment: Yes (1)** Acknowledging the diagnostic message deletes the message.

**Acknowledgment: Yes (2)** Acknowledging the diagnostic message deletes the message and enables the outputs.

## 8.5 Connection errors to satellites

Table 8-6 Connection errors to satellites

Error cause	Error code	Short description	Remedy	Acknowledgment
(hex)	(hex)			
<b>Incorrect F_Address</b>	<b>03FC</b>	F_Address set incorrectly on the IB IL 24 LPSDO 8-PAC.	Check switch position and value in software and adapt accordingly.	Reload project.
<b>Communication connection faulty</b>	<b>050x</b>	One or more safe communication connections are faulty.	Check and adapt data state and copy routines.	Acknowledgment required. (The OAR bit is set in the diagnostic register of the IB IL 24 LPSDO 8-PAC; see "Dev-Diag-LPSDO (diagnostic LPSDO)" on page A-15)
	<b>0501</b>	1st connection faulty		
	<b>0502</b>	2nd connection faulty		
	<b>0504</b>	3rd connection faulty		
<b>Incorrect F_Source_Address</b>	<b>07C2</b>	Set address of the IB IL 24 LPSDO 8-PAC in the software and on the device do not match.	Check switch position and value in software and adapt accordingly.	Power up. (The PUR bit is set in the diagnostic register of the IB IL 24 LPSDO 8-PAC; see "Dev-Diag-LPSDO (diagnostic LPSDO)" on page A-15)
<b>Incorrect operating mode</b>	<b>07C3</b>	The operating mode set on the device is not supported.	Check and correct switch position.	
<b>Incorrect F_Source_Address</b>	<b>07C4</b>	The F_Source_Address set on the device is not within the permissible value range.	Check and correct switch position.	
<b>Processing time exceeded</b>	<b>07C8</b>	The maximum permissible processing time of the safe logic has been exceeded.	Reduce size of user logic.	Reload project.

## 8.6 PCP errors when transferring the parameterization to the IB IL 24 LPSDO 8-PAC

When transferring the parameterization to the IB IL 24 LPSDO 8-PAC, the following PCP errors may be caused by the user:

PCP errors:

- Error\_Class 6
- Error\_Code "object attribute inconsistent"

The additional code specifies the precise error cause.

Table 8-7 Connection errors to satellites

Additional code (hex)	Short description	Remedy
01	The received project header does not correspond to the one stored on the device or is invalid (incorrect CRC).	Delete old project and load new project or use old project.
02 03	The components (logic block, address block, and project header) of the parameters to be transferred are not consistent or do not belong to the same project.	Make sure that all the blocks originate from the same test in the SAFECONF tool.
04	The last saved project was not deleted correctly.	Make sure that the appropriate organizational measures have been observed.
10	The PCP objects were not written in the expected order.	Correct order
11	The length of the received data does not correspond to the expected value.	
12	Incorrect operating mode (in SafetyBridge multiplexer mode, no parameter data is expected) Or	Check and correct operating mode
	Incorrect operating state (a new project can only be loaded if the old project has been deleted)	Delete old project, then load new project
14	Implausible segment number for segmented object transfer	

## 8.7 Acknowledging an error

In the SafetyBridge system, the errors of the IB IL 24 LPSDO 8-PAC as well as those of the corresponding island satellites must be acknowledged via the IB IL 24 LPSDO 8-PAC.

After removing the cause of an error, the diagnostic message must be acknowledged. To do this, set the corresponding bit in the "Dev\_Ackn\_Reg" register (see "Descriptions of the registers" on page A-14).



**WARNING: Acknowledgment may result in a hazardous system state**

With the exception of a few special cases, the acknowledgment of an error immediately returns the safe input or output to the operating state. Before acknowledging an error you must therefore make sure that the acknowledgment will not cause the machine to switch to a dangerous state.

When planning the machine or system, ensure that acknowledgment is only possible if the danger zone is visible.

If in the event of failure the safety module is replaced, please proceed as described in Section 4, "Assembly, removal, and electrical installation" and "Restart after replacing a safety module" on page 7-3.

## 9 Maintenance, repair, decommissioning, and disposal

### 9.1 Maintenance

The device is designed in such a way that maintenance work is not required during the duration of use. However, depending on the application and connected I/O devices it may be necessary to test the function of the I/O devices and the safety chain at regular intervals.

The duration of use of the module is 20 years.

Repeat testing within this time is not required.

Carry out maintenance of connected I/O devices (e.g., light grid) according to the relevant manufacturer specifications.

### 9.2 Repair

Repair work may not be carried out on the safety module. In the event of an error, send the module to Phoenix Contact.

It is strictly prohibited to open the safety module. In order to prevent the manipulation of the module and to detect the unauthorized opening of the module, a security seal is applied to the module. This security seal is damaged in the event of unauthorized opening. In this case, the correct operation of the safety module can no longer be ensured.

### 9.3 Decommissioning and disposal

The machine or system manufacturer specifies the procedure for decommissioning. Decommissioning may only take place according to these specified procedures.

When decommissioning a SafetyBridge system or parts thereof, ensure that the safety modules used:

- Are correctly reused in another system.  
In this case, please observe the storage and transport requirements according to the technical data (see "IB IL 24 LPSDO 8-PAC" on page 10-1).
- Or**
- Are disposed of according to the applicable environmental regulations, and in this case can never be reused.

## 10 Technical data and ordering data

### 10.1 System data

#### 10.1.1 Inline

For system data, please refer to the following user manual:

Inline Automation terminals of the Inline product range  
IL SYS INST UM E

#### 10.1.2 SafetyBridge system

##### SafetyBridge system

Shutdown time $t_{OUT}$	20 ms
Maximum number of SafetyBridge islands in the system	31
Maximum number of modules within a SafetyBridge island	1 IB IL 24 LPSDO 8-PAC 3 IB IL 24 PSDI 8-PAC
Memory capacity	5000 bytes for safety logic



For the system data for your system, please refer to the corresponding documentation for the controller used.

### 10.2 IB IL 24 LPSDO 8-PAC

##### General data

Housing dimensions (width x height x depth)	48.8 mm x 119.8 mm x 71.5 mm
Weight (with connectors)	200 g
Operating mode	
SafetyBridge	Process data mode with 6 or 16 words
Transmission speed (local bus)	500 kbaud or 2 Mbaud
Ambient temperature	
Operation	-25°C to +55°C
Storage/transport:	-25°C to +85°C

**IB IL 24 LPSDO 8-PAC****General data (continued)**

## Humidity

## Operation

75% on average, 85% occasionally (no condensation)



In the range from -25°C to +55°C appropriate measures against increased humidity must be taken.

## Storage/transport:

75% on average; 85% occasionally (no condensation)



For a short period, slight condensation may appear on the outside of the housing.

## Air pressure

## Operation

80 kPa to 108 kPa (up to 2000 m above sea level)

## Storage/transport:

66 kPa to 108 kPa (up to 3000 m above sea level)

## Degree of protection

IP20

## Housing material

Plastic PBT, self-extinguishing (V0)

## Air and creepage distances

According to IEC 60439-1, derived from IEC 60664-1

## Class of protection

III (PELV)

## Gases that may endanger functions according to DIN 40046-36, DIN 40046-37

Sulfur dioxide (SO<sub>2</sub>)

Concentration 10 ±0.3 ppm

## Ambient conditions:

- Temperature 25°C ±2 K
- Humidity 75% ±5%
- Test duration 10 days

Hydrogen sulfide (H<sub>2</sub>S)

Concentration 1 ±0.3 ppm

## Ambient conditions:

- Temperature 25°C ±2 K
- Humidity 75% ±5%
- Test duration 4 days

## Resistance of the housing material to termites

Resistant

## Resistance of housing material to fungal decay

Resistant

## Ambient compatibility

Not resistant to chloroform

## Connection data for Inline connectors

## Connection method

Spring-cage terminals

## Conductor cross-section

0.2 mm<sup>2</sup> to 1.5 mm<sup>2</sup> (solid or stranded), 24 - 16 AWG

## Supported stop category according to EN 60204

0  
1 in error-free state**Mechanical requirements**

## Vibration according to IEC 60068-2-6

Operation: 2g, Criterion A

## Shock according to IEC 60068-2-27

15g over 11 ms, Criterion A

**Technical data according to IEC 61508/EN 61508**

## Probability of a hazardous failure per hour for the entire module (PFH)

SIL 2: 1% of 10<sup>-6</sup>, maximum (corresponds to 1 \* 10<sup>-8</sup>)  
 SIL 3: 1% of 10<sup>-7</sup>, maximum (corresponds to 1 \* 10<sup>-9</sup>)  
 Depends on the parameterization (see Table 6-3 on page 6-3)

## Technical data and ordering data

### Technical data according to IEC 61508/EN 61508 (continued)

Hardware fault tolerance (HFT) of the module	1
Permissible duration of use	20 years
Achievable SIL	SIL 2 (single-channel) SIL 3 (two-channel) Depends on the parameterization and wiring (see "Connection options for actuators depending on the parameterization" on page 2-6 and "Connection examples for safe outputs" on page 6-1)

### Technical data according to DIN EN 62061

SIL claim limit	SIL CL = SIL 2 (single-channel) SIL CL = SIL 3 (two-channel) Depends on the parameterization and wiring (see "Connection options for actuators depending on the parameterization" on page 2-6 and "Connection examples for safe outputs" on page 6-1)
Mission time	20 years
Safe failure fraction (SFF)	99%
Probability of a hazardous failure per hour for the entire module (PFH)	SIL CL 2: 1% of $10^{-6}$ , maximum (corresponds to $1 \cdot 10^{-8}$ ) SIL CL 3: 1% of $10^{-7}$ , maximum (corresponds to $1 \cdot 10^{-9}$ ) 1% of $10^{-7}$ , maximum (corresponds to $1 \cdot 10^{-9}$ ) Depends on the parameterization (see Table 6-3 on page 6-3)
Hardware fault tolerance (HFT) of the module	1
Permissible duration of use	20 years

### Technical data according to EN ISO 13849-1

Achievable performance level	PL e (two-channel) PL d (single-channel) Depends on the parameterization and wiring (see "Connection options for actuators depending on the parameterization" on page 2-6 and "Connection examples for safe outputs" on page 6-1) See also "Achievable safety depending on the modules used" on page A-27.
Diagnostic coverage (DC)	99%
Mean time to dangerous failure (MTTFd)	For single-channel assignment: 100 years For two-channel assignment: 100 years

### Supply voltage $U_L$ (logic)



The safety terminal is supplied with communications power via the bus coupler or a designated power terminal in the station. The communications power is led in the Inline station via potential routing. For the technical data, please refer to the data sheet for the bus coupler or power terminal used.

Current consumption	230 mA, maximum
---------------------	-----------------

### Supply voltage $U_M$ (actuators)



The safety terminal is supplied with main voltage  $U_M$  via the bus coupler or a power terminal in the station. The main voltage is led in the Inline station via potential routing. For the technical data, please refer to the data sheet for the bus coupler or power terminal used.



#### **WARNING: Loss of the safety function when using unsuitable power supplies**

Only use power supplies according to EN 50178/VDE 0160 (PELV).

Nominal voltage	24 V DC according to EN 61131-2 and EN 60204
Tolerance	-15%/+20% including an entire AC voltage component with peak value of 5%

**IB IL 24 LPSDO 8-PAC****Supply voltage  $U_M$  (actuators) (continued)**

Ripple	3.6 V <sub>PP</sub>
Permissible voltage range	19.2 V DC to 30.0 V DC, ripple included
Current consumption	30 mA, typical (all outputs set) (plus actuator current)
Permissible interruption time	10 ms; Within this time, the output voltage for the safe outputs fails as the outputs are not internally buffered.
Surge protection	Yes (in the bus coupler/power terminal)
Protection against polarity reversal	Yes (in the bus coupler/power terminal)

**NOTE: Module damage due to polarity reversal**

Polarity reversal places a burden on the electronics and, despite protection against polarity reversal, can damage the module. Therefore, polarity reversal must be prevented.

Undervoltage detection	Yes, at 17 V, approximately
Diagnostic indicators	Green $U_M$ LED (see "Local diagnostic and status indicators" on page 2-7)
External fuse	8 A slow-blow, maximum

**NOTE: Module damage in the event of overload**

The power supply unit must be able to supply four times (400%) the nominal current of the external fuse.

**Safe digital outputs OUT0 to OUT3**

Number	4 two-channel or 8 single-channel (positive switching)
Power supply	From supply voltage $U_M$
Maximum output current per output	2 A
Maximum output current for all outputs (total current)	6 A (observe derating and maximum output current for each group)
Maximum output current for each group (total current)	
Group 1 (OUT0_K1, OUT1_K1, OUT2_K1, OUT3_K1)	3 A
Group 2 (OUT0_K2, OUT1_K2, OUT2_K2, OUT3_K2)	3 A
Maximum output voltage in the low state	< 5 V

**WARNING: Loss of safety function**

At this voltage, the load must not switch to nor remain in the ON state. Please take this into consideration when selecting the actuator.

Maximum leakage current in the low state	2 mA
--	------

**WARNING: Loss of safety function**

At this current, the load must not switch to nor remain in the ON state. Please take this into consideration when selecting the actuator.

Minimum withstand voltage of the connected loads	> 5 V
Maximum inductive load	1 H

Technical data and ordering data

Safe digital outputs OUT0 to OUT3 (continued)

Maximum capacitive load depending on the current

$$C = 1 \text{ s} / (R \cdot 1400)$$

Where:

- C Load capacity in F
- R Load resistance in ohm

Maximum capacitive load depending on the load current

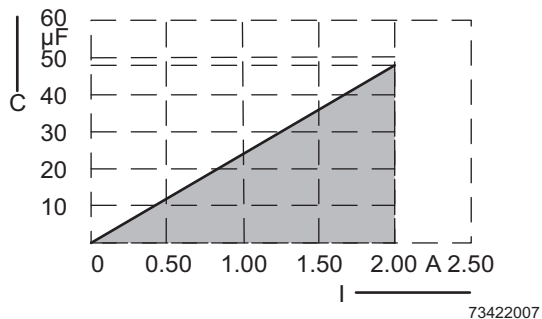

Key:

- C Load capacity in µF
- I Load current in A
- Hatched area: Permissible range

Minimum load	1.5 kΩ (16 mA at 24 V)
Limitation of the voltage induced on circuit interruption	-15 V
Output voltage	U <sub>M</sub> - 1 V, approximately
Simultaneity	100% up to 45°C (observe maximum current load)
Derating	Up to 50°C, total current of all outputs 6 A, maximum Up to 55°C, total current of all outputs 4 A, maximum
Maximum switching frequency	1 Hz; 0.2 Hz at > 1 A
Filter time	None
Switch-off delay for shutdown according to stop category 1	Can be parameterized; 150 ms to 630 s; see "Parameterization of the safe outputs" on page 5-2 Accuracy ±5% of parameterized value
Maximum duration of the test pulses (when switched off; active driving)	1 ms
Maximum duration of the test pulses (when switched on)	3 ms (depending on the load capacity)
Status indicators	One green LED (two-color LED green/red) per output (see "Local diagnostic and status indicators" on page 2-7)
Diagnostic indicators	One red LED (two-color LED green/red) per output (see "Local diagnostic and status indicators" on page 2-7)



**WARNING: Loss of safety function**

- Connect the ground of the actuator directly to the ground terminal point of the corresponding output on the Inline connector. An external ground may not be used.
- The connected load must not respond in a hazardous way to test pulses.

**IB IL 24 LPSDO 8-PAC****Electrical isolation/isolation of the voltage areas**

To provide electrical isolation between the logic level and the I/O area, it is necessary to supply the bus coupler and this safety module from separate power supply units. Interconnection of the power supply units in the 24 V area is not permitted (see also user manual).

**Separate potentials in the system comprising bus coupler/power terminal and safety module****- Test distance**

5 V supply incoming remote bus/7.5 V supply (bus logic)

5 V supply outgoing remote bus/7.5 V supply (bus logic)

7.5 V supply (bus logic)/24 V supply  $U_M$ , FE**- Test voltage**

500 V AC, 50 Hz, 1 min.

500 V AC, 50 Hz, 1 min.

500 V AC, 50 Hz, 1 min.

**Approvals**

For the latest approvals, please visit [www.phoenixcontact.net/download](http://www.phoenixcontact.net/download).

**10.3 Conformance with EMC Directive****Conformance with EMC Directive 2004/108/EC****Noise immunity test according to DIN EN 61000-6-2**

Electrostatic discharge (ESD)

EN 61000-4-2  
(IEC 61000-4-2)

Criterion B

6 kV contact discharge, 8 kV air discharge

Electromagnetic fields

EN 61000-4-3  
(IEC 61000-4-3)

Criterion A, field strength 10 V/m

Fast transients (burst)

EN 61000-4-4  
(IEC 61000-4-4)

Criterion B, test voltage 2 kV

Surge voltage

EN 61000-4-5  
(IEC 61000-4-5)

Test intensity 2, criterion B

DC supply lines:  
0.5 kV/0.5 kV (symmetrical/asymmetrical)Signal lines:  
1.0 kV/2.0 kV (symmetrical/asymmetrical)

Conducted interference

EN 61000-4-6  
(IEC 61000-4-6)

Criterion A, test voltage 10 V

**Noise emission test according to DIN EN 61000-6-4**

Noise emission

EN 55011

Class A, industrial applications

## 10.4 Ordering data

### 10.4.1 Ordering data: Safety module

Description	Type	Order No.	Pcs./Pkt.
Inline module with integrated safety logic and safe digital outputs	IB IL 24 LPSDO 8-PAC	2916024	1

### 10.4.2 Ordering data: Accessories

Description	Type	Order No.	Pcs./Pkt.
Connector set as replacement item	IB IL 24 SDO 8-PLSET/CP	2916927	1 set

### 10.4.3 Ordering data: Software

Description	Type	Order No.	Pcs./Pkt.
Parameterization and configuration tool	SAFECONF	2986119	1



The software can be downloaded free of charge at [www.phoenixcontact.net/download](http://www.phoenixcontact.net/download).

### 10.4.4 Ordering data: Documentation

Description	Type	Order No.	Pcs./Pkt.
<b>Inline</b>			
"Automation terminals of the Inline product range" user manual	IL SYS INST UM E	2698737	1
Quick Start Guide for IB IL 24 LPSDO 8-PAC	UM QS EN IB IL 24 LPSDO 8-PAC	On request	1



Make sure you always use the latest documentation. It can be downloaded at [www.phoenixcontact.net/download](http://www.phoenixcontact.net/download).

---

# A Appendix: SafetyBridge system

## A 1 The SafetyBridge system

### A 1.1 SafetyBridge technology – Maximum flexibility and safety

In all safety applications in which conventional safety relays are not flexible enough, parallel wiring proves too complex due to the expansiveness of the safety circuits or the use of a safe bus system in connection with a safe controller is cost-prohibitive, SafetyBridge technology from Phoenix Contact offers a cost-effective solution.

The SafetyBridge system works independently of the relevant network and the standard control system used. Both simply act as a transport medium for safe data packets, which are exchanged between the safe input and safe output modules. The safe inputs and outputs are distributed in the network and do not require a higher-level safety controller or a separate safety bus system. The user therefore does not have to choose a safe network such as INTERBUS Safety or PROFIsafe with the relevant available safety controllers, and instead can continue to use a proven system of appropriate technologies. This means that a never-before-seen level of flexibility can be achieved in bus-based safety applications.

#### **Direct processing of safety operations in the module**

SafetyBridge technology has been integrated into the proven Inline I/O system. No special installation guidelines have to be observed when installing corresponding modules. They can be distributed in the network and operated at any point in the I/O station. Due to the technology used, a special bus coupler is not required as the safety operations are processed directly in the IB IL 24 LPSDO 8-PAC intelligent safe output module. Thanks to the comprehensive range of parameterization options, the input or output channels can be adapted flexibly to the relevant application. Data transmission over the network from the safe input module to the output module is protected by a special protocol, which is operated by the intelligent output module. The standard control system simply has to copy standard I/O data bidirectionally between the input and output modules. Like the network used, it does not perform any safety-related tasks.

#### **Easy configuration of the safety logic**

The safety mechanisms used in the SafetyBridge system, such as the "black channel" principle, are based on proven technologies that have been used for several years in the INTERBUS Safety and PROFIsafe system. With appropriate parameterization, applications up to Cat. 4/SIL 3/SIL CL 3/PL e can be implemented. The SAFECONF software enables user-friendly parameterization of the safe input and output channels and creation of the safety logic. The tool does not require programming experience, as predefined function blocks are available for virtually every application. SafetyBridge technology can be used to implement distributed safety applications cost-effectively in a network independently of the network and standard control system.

## A 1.2 Overview of SafetyBridge system features

- Network independent
- Controller independent
- No higher-level safety controller required
- Simple
- Maximum of three connections to remote modules (satellites)
- All data, including parameterizations, is located on the standard control system
- Only the IB IL 24 LPSDO 8-PAC module is parameterized by the standard control system
- No parameterization required in multiplexer mode
- The SAFECONF parameterization tool can be downloaded free of charge (see "Ordering data" on page 10-7)
- Enable principle

## A 2 System topology

### A 2.1 General topology

A SafetyBridge system can be integrated into various bus systems (e.g., INTERBUS, PROFINET, PROFIBUS). The standard bus system is thus supplemented by components to achieve safety.

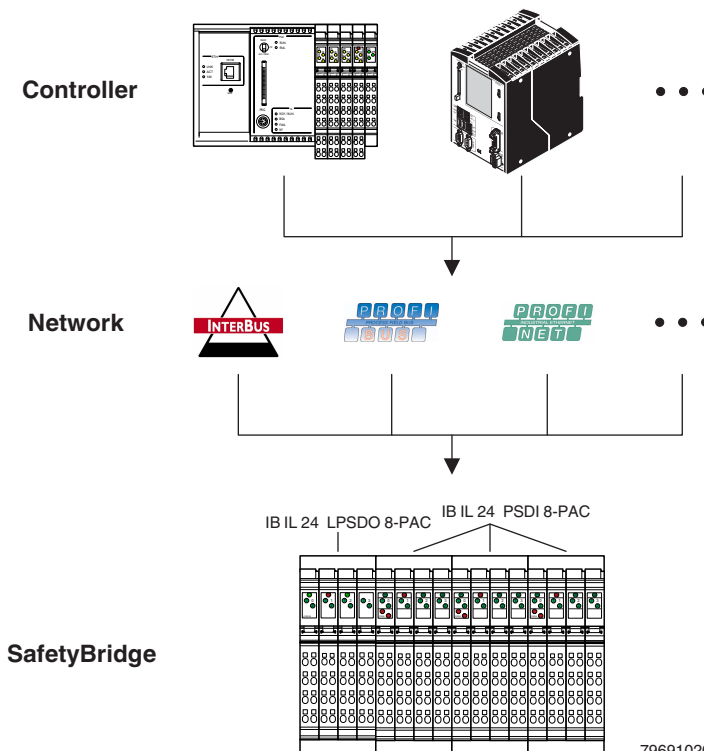

79691020

Figure A-1 Network independence

---

<b>Control level</b>	A standard control system is used as the controller (see also "Network and controller requirements" on page A-3).
<b>I/O level</b>	Safe devices are integrated into the Inline station at I/O level. Safe and standard devices can be operated simultaneously in the overall system.
<b>Communication</b>	Communication takes place via the standard control system and the standard bus system using safe data packets.
<b>System</b>	The system comprises a standard control system and up to 31 SafetyBridge islands.
<b>SafetyBridge island</b>	<p>Each SafetyBridge island comprises one SafetyBridge module with integrated safety logic (IB IL 24 LPSDO 8-PAC) and up to three distributed SafetyBridge modules without safety logic (e.g., IB IL 24 PSDI 8-PAC). The module with integrated safety logic is referred to as the island node, while the modules without safety logic are referred to as remote devices or satellites.</p> <p>The satellites and the IB IL 24 LPSDO 8-PAC are assigned to an island using island numbers that are specified in the parameterization tool. The satellites are numbered in the order they are assigned in SAFECONF.</p>

## A 2.2 Network and controller requirements

The SafetyBridge system does not place any special requirements on the standard control system. However, it must be able to perform the following tasks:

Network:

- Deterministic network; pauses caused by sporadic errors must not exceed the shutdown time

Controller:

- Support of acyclic services
- Fast enough that it can meet time expectations for the response time
- Sufficient memory to save configuration and parameter data records
- Data consistency is ensured when copying data  
Data consistency must at least be ensured using the data telegram of a module.
- In INTERBUS: The bus cycle time must not fall below 2 ms



Function blocks for copying data and downloading the configuration are available for selected controllers.

### **A 2.3 Safe input and output devices**

Safe input and output devices form the interface to connected I/O devices. The devices control, e.g., contactors or valves, and/or read the input status of connected safety-related sensors.

The internal structure of the devices enables component failures, interruptions in transmission or the absence of data to be detected and reported immediately.

Even errors in the wiring or internal device errors can be detected. Errors are indicated via the process image of the devices, the function blocks, and the device LEDs and can be evaluated by the user.

The safe I/O devices are from the Inline product range. Their design and interfaces correspond to standard Inline I/O devices. This means that no additional installation effort is required.

The devices are parameterized using the SAFECNF software according to the safety function that is to be performed. The parameterization and wiring of the inputs and outputs depends on the application (e.g., single or two-channel). For more detailed information about the parameterization options, please refer to the user manual for the relevant device. The wiring and parameterization of devices determines which errors will be detected.

## A 3 SafetyBridge address assignment



**NOTE: Malfunction in the event of incorrect addressing**

Make sure that in an overall system comprising the SafetyBridge system and any higher-level PROFIsafe system, the addresses (address within the SafetyBridge system and F-Address of the PROFIsafe system) are unique. Duplicate address assignment is not permitted.



**NOTE: Malfunction during mixed operation**

During simultaneous use of SafetyBridge V1/V2 and SafetyBridge V3 on a controller, make sure that the island number of the SafetyBridge V3 system is  $\geq 8$ .

This should be checked during overall validation of the system.

The SafetyBridge address comprises an island number and the position in the bus navigator of the SAFECONF software tool.

Enter the address for the IB IL 24 LPSDO 8-PAC in SAFECONF.



The switch position can be displayed in SAFECONF by right-clicking in the hardware editor and selecting "Display address switch".

Table A-1 SafetyBridge address IB IL 24 LPSDO 8 V3-PAC

SafetyBridge address									
Island number					Reserved				
9	8	7	6	5	4	3	2	1	0
1 <sub>dec</sub> to 31 <sub>dec</sub>					0 <sub>dec</sub>				

Table A-2 SafetyBridge address for the IB IL 24 LPSDO 8-PAC

SafetyBridge address							
Island number					Satellite number		
7	6	5	4	3	2	1	0
1 <sub>dec</sub> to 31 <sub>dec</sub>					0 <sub>dec</sub>		

Table A-3 SafetyBridge address, e.g., IB IL 24 PSDI 8-PAC

SafetyBridge address							
Island number					Satellite number		
7	6	5	4	3	2	1	0
1 <sub>dec</sub> to 31 <sub>dec</sub>					1 <sub>dec</sub> to 7 <sub>dec</sub>		

Example:

## IB IL 24 LPSDO 8-PAC

Table A-4 Example 1: SafetyBridge addresses

	Island number					Satellite number		
	7	6	5	4	3	2	1	0
IB IL 24 LPSDO 8-PAC	1 <sub>dec</sub>					0 <sub>dec</sub>		
	0	0	0	0	1	0	0	0
	SafetyBridge address: 8 <sub>dec</sub> (8 <sub>hex</sub> )							
IB IL 24 PSDI 8-PAC Position 1	1 <sub>dec</sub>					1 <sub>dec</sub>		
	0	0	0	0	1	0	0	1
	SafetyBridge address: 9 <sub>dec</sub> (9 <sub>hex</sub> )							

Table A-5 Example 2: SafetyBridge addresses

	Island number					Satellite number		
	7	6	5	4	3	2	1	0
IB IL 24 LPSDO 8-PAC	16 <sub>dec</sub> (10 <sub>hex</sub> )					0 <sub>dec</sub>		
	1	0	0	0	0	0	0	0
	SafetyBridge address: 128 <sub>dec</sub> (80 <sub>hex</sub> )							
IB IL 24 PSDI 8-PAC Position 3	16 <sub>dec</sub> (10 <sub>hex</sub> )					3 <sub>dec</sub>		
	1	0	0	0	0	0	1	1
	SafetyBridge address: 131 <sub>dec</sub> (83 <sub>hex</sub> )							

**Address examples**

Figure A-2 and Table A-6 illustrate examples of addresses in the SafetyBridge system for three islands.

Island 1 (00001xxx, red) and island 2 (00010xxx, green) operate in SafetyBridge mode. Island 3 (00011xxx, blue) operates in SafetyBridge multiplexer mode.

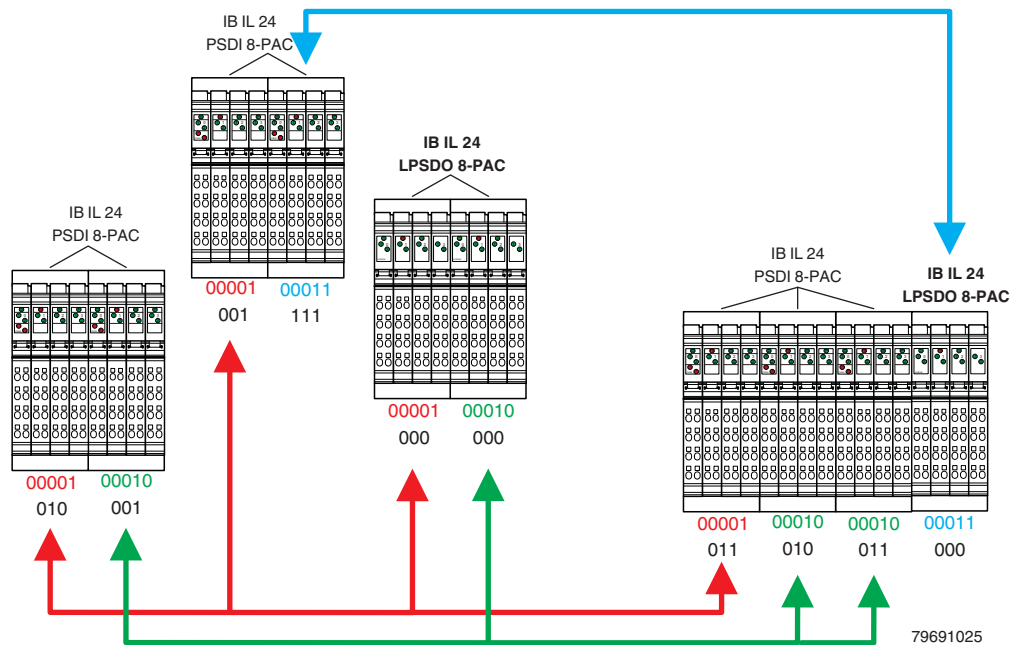

Figure A-2 Example addresses for SafetyBridge islands 1 to 3

All the possible addresses for island numbers 1 to 3 are listed in Table A-6. The addresses actually used in the example in Figure A-2 are in bold.

Table A-6 Example addresses for SafetyBridge islands

Addresses for island number 1 (red in Figure A-2)	Addresses for island number 2 (green in Figure A-2)	Addresses for island number 3 (blue in Figure A-2)	Device
<b>00001 000 (08<sub>hex</sub>)</b>	<b>00010 000 (10<sub>hex</sub>)</b>	<b>00011 000 (18<sub>hex</sub>)</b>	IB IL 24 LPSDO 8-PAC (island node)
00001 001 (09 <sub>hex</sub> )	00010 001 (11 <sub>hex</sub> )		Assigned IB IL 24 PSDI 8-PAC in SafetyBridge mode
00001 010 (0A <sub>hex</sub> )	00010 010 (12 <sub>hex</sub> )		Assigned IB IL 24 PSDI 8-PAC in SafetyBridge mode
00001 011 (0B <sub>hex</sub> )	00010 011 (13 <sub>hex</sub> )		Assigned IB IL 24 PSDI 8-PAC in SafetyBridge mode
		<b>00011 111 (1F<sub>hex</sub>)</b>	Assigned IB IL 24 PSDI 8-PAC in SafetyBridge multiplexer mode

In SafetyBridge multiplexer mode, the IB IL 24 LPSDO 8-PAC is always assigned one IB IL 24 PSDI 8-PAC with the address xxxxx111 (xxxxx = island number). The IB IL 24 LPSDO 8-PAC and IB IL 24 PSDI 8-PAC modules operate with a fixed parameterization.

To differentiate between SafetyBridge and SafetyBridge multiplexer mode, in SafetyBridge mode the address with "111" in the last three bits is not used. If an address with the format "xxxxx111" is specified in SafetyBridge mode, the module enters the safe state.

Therefore in SafetyBridge multiplexer mode, the address xxxxx111 set on the IB IL 24 PSDI 8-PAC corresponds to the setting for Inline Safety multiplexer mode and the island number on the IB IL 24 LPSDO 8-PAC.

## A 4 Operating modes and setting the DIP switches in the SafetyBridge system

The DIP switches are located on the left-hand side of the safety module.

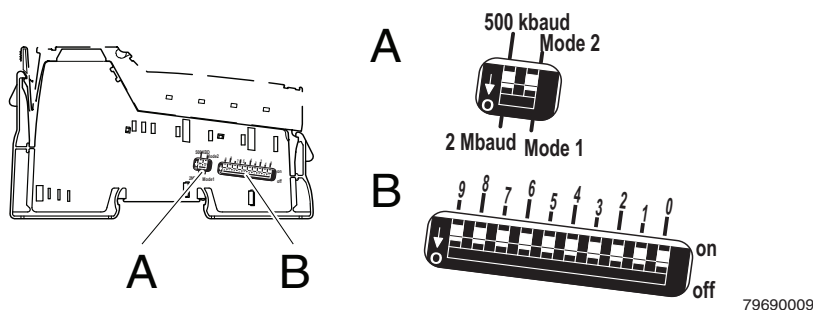

Figure 10-1 DIP switches

- A Switch for setting the transmission speed and the operating mode
- B Switch for setting the address



For more detailed information about the function of the DIP switches, please refer to "Setting the DIP switches" on page 4-2.

The SafetyBridge system supports two operating modes:

- SafetyBridge
- SafetyBridge multiplexer

The operating mode is set exclusively via the IB IL 24 LPSDO 8-PAC switch.

It is switched via switch 9 of the 10-pos. DIP switch (B) according to Table A-8. In SafetyBridge mode, the "Mode" DIP switch can be used to switch the data width between 16 and 24 words.

In SafetyBridge multiplexer mode, the data width is 6 words.

In both operating modes, the address of the IB IL 24 LPSDO 8-PAC is set via switches 7 to 3 of the 10-pos. DIP switch. The last 3 bits (switches 2 to 0) must always be 0.

This address 0 is not permitted.

The following 31 addresses are available for the IB IL 24 LPSDO 8-PAC:

08<sub>hex</sub>, 10<sub>hex</sub>, 18<sub>hex</sub>, 20<sub>hex</sub>, 28<sub>hex</sub> ... 90<sub>hex</sub>, 98<sub>hex</sub>, A0<sub>hex</sub>, A8<sub>hex</sub>, B0<sub>hex</sub>, B8<sub>hex</sub> ... F0<sub>hex</sub>, F8<sub>hex</sub>.

The first five bits represent the island number. An "island" always comprises the IB IL 24 LPSDO 8-PAC and the IB IL 24 PSDI 8-PAC assigned to it.

## A 4.1 Module switch positions

The following tables show the settings on the IB IL 24 PSDI 8-PAC and IB IL 24 LPSDO 8-PAC.

Table A-7 IB IL 24 PSDI 8-PAC switch position

IB IL 24 PSDI 8-PAC		
Address	Mode	Operating mode
1 <sub>hex</sub> ... 3FE <sub>hex</sub>	on (Mode 2)	SafetyBridge, parameterization by the IB IL 24 LPSDO 8-PAC

For the SafetyBridge system, no other switch positions are permitted on the IB IL 24 PSDI 8-PAC.

Table A-8 IB IL 24 LPSDO 8-PAC switch position

IB IL 24 LPSDO 8-PAC					
DIP switches for address				Mode	Operating mode
9	8	7 ... 3	2 ... 0		
		Address: 31 addresses (08 <sub>hex</sub> , 10 <sub>hex</sub> , 18 <sub>hex</sub> , ..., F8 <sub>hex</sub> ) Island number	Must be 0 (off)		
off	Reserved (must be off)				off (Mode 1)
on			Must be 0 (off)	on (Mode 2)	Reserved
				No function	SafetyBridge multiplexer 6 words

Table A-9 500 KBD/2 MBD switch for all modules

500 KBD/2 MBD	Transmission speed
500 KBD	500 kbps
2 MBD	2 Mbps



Only use devices with a uniform transmission speed within an Inline station (a local bus). A mixture of devices with different transmission speeds cannot be operated.

## IB IL 24 LPSDO 8-PAC

### A 4.2 SafetyBridge multiplexer mode

In this operating mode, the input data of an IB IL 24 PSDI 8-PAC safe input module is output one-to-one to the output terminals of the IB IL 24 LPSDO 8-PAC. A controller is still required as this copies the data (see also Figure A-5 "I/O image and data flow in multiplexer mode" on page A-14).

The IB IL 24 LPSDO 8-PAC and IB IL 24 PSDI 8-PAC, which should be operated in multiplexer mode, are configured and assigned to one another via the switch position of the DIP switches (see "Setting the DIP switches" on page 4-2). The parameterizations of both modules are fixed and cannot be modified. A parameterization tool is not required for this operating mode.



Multiplexer mode is intended as a replacement for cabling. A stand-alone solution, such as that using MUX modules, cannot be implemented using multiplexer mode.



**NOTE: Not a safe application**

In order to ensure correct use, subsequent safety logic (an evaluation unit) is required.

The IB IL 24 LPSDO 8-PAC parameterizes both local safe I/O devices and the input module as follows:

Table A-10 Parameterization of **all** safe outputs of the IB IL 24 LPSDO 8-PAC

Parameterization	Parameterized as	Remark
Assignment	<b>Used</b>	The parameterization is set automatically and cannot be changed.
Output	<b>Single-channel</b>	
Switch-off delay for stop category 1	<b>Disabled</b>	
Switch-off delay for stop category 1	–	
Value range of switch-off delay for stop category 1	–	
Test pulses (output disabled) (test impulses (output switched off))	<b>Enabled</b>	
Enable function	<b>Disabled</b>	

The watchdog time ( $t_{FWD}$ ) is fixed to the value 200 ms.

Table A-11 Parameterization of **all** safe inputs of the IB IL 24 PSDI 8-PAC

Parameterization	Parameterized as	Remark
<b>Input</b>		
Assignment	<b>Used</b>	The parameterization is set automatically and cannot be changed.
Evaluation	<b>Single-channel</b>	
Sensor type	<b>Standard sensor</b>	
Filter time ( $t_{Filter}$ ) (filter duration)	<b>5 ms</b>	
Symmetry	<b>Disabled</b>	
Clock selection (pulse selection)	<b>UT1 for inputs of channel 1</b> <b>UT2 for inputs of channel 2</b>	
Bouncing time monitoring (bounce time monitoring)	<b>Disabled</b>	
Start inhibit in the event of symmetry violation	<b>Disabled</b>	
Input signal	<b>Equivalent</b>	
<b>Clock output</b>		
	<b>UT1 ON/UT2 ON</b>	

**Application example**

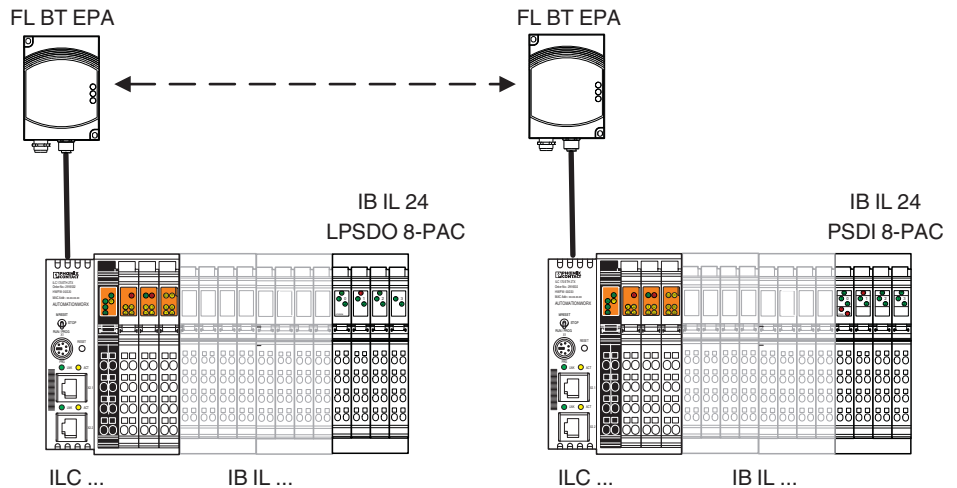

Figure A-3 Example

- ILC ... Standard control system
- IB IL ... Inline terminals according to your requirements
- FL BT EPA Bluetooth Ethernet port adapter

## A 5 Process image

### A 5.1 Structure of the process image

Table A-12 Key for Figure A-4

Designation	Meaning
PII	Process image of inputs
PIO	Process image of outputs
7, 6	Number of bytes to be transmitted
Prot-x	Protocol data
<b>For the standard control system, read-only parts (bold in PII)</b>	
Dev-Diag-LPSDO	Diagnostic data of all modules
Data-x	Safe input data of IB IL 24 PSDI 8-PAC modules
App-Diag-LPSDO	Freely configurable feedback signals of the IB IL 24 LPSDO 8-PAC to the standard control system
Feedback-Data-LPSDO	Automatically read back safe output data
<b>For the standard control system, read/write parts (bold in PIO)</b>	
Dev-Ack-LPSDO	Acknowledgment of device and communication errors
App-Ack-LPSDO	Freely configurable acknowledgment signals of the standard control system to the IB IL 24 LPSDO 8-PAC
Data-LPSDO	Standard data of the standard control system, which is to enable the IB IL 24 LPSDO 8-PAC

Figure A-4 shows an example of the structure of the I/O image and data flow for the 16-word wide version of the IB IL 24 LPSDO 8-PAC. For an explanation of the data flow, please refer to A 6, "Implementation of data flow between the standard control system and the safety modules" on page A-18.

If a SafetyBridge island is made up of a different constellation, the following rules apply for mapping the individual submodules within the IB IL 24 LPSDO 8-PAC:

- All modules are packed without gaps within the IB IL 24 LPSDO 8-PAC.
- The corresponding SafetyBridge addresses within an island are in ascending order and without gaps.

Figure A-5 shows an example of the structure of the I/O image and data flow for multiplexer mode.

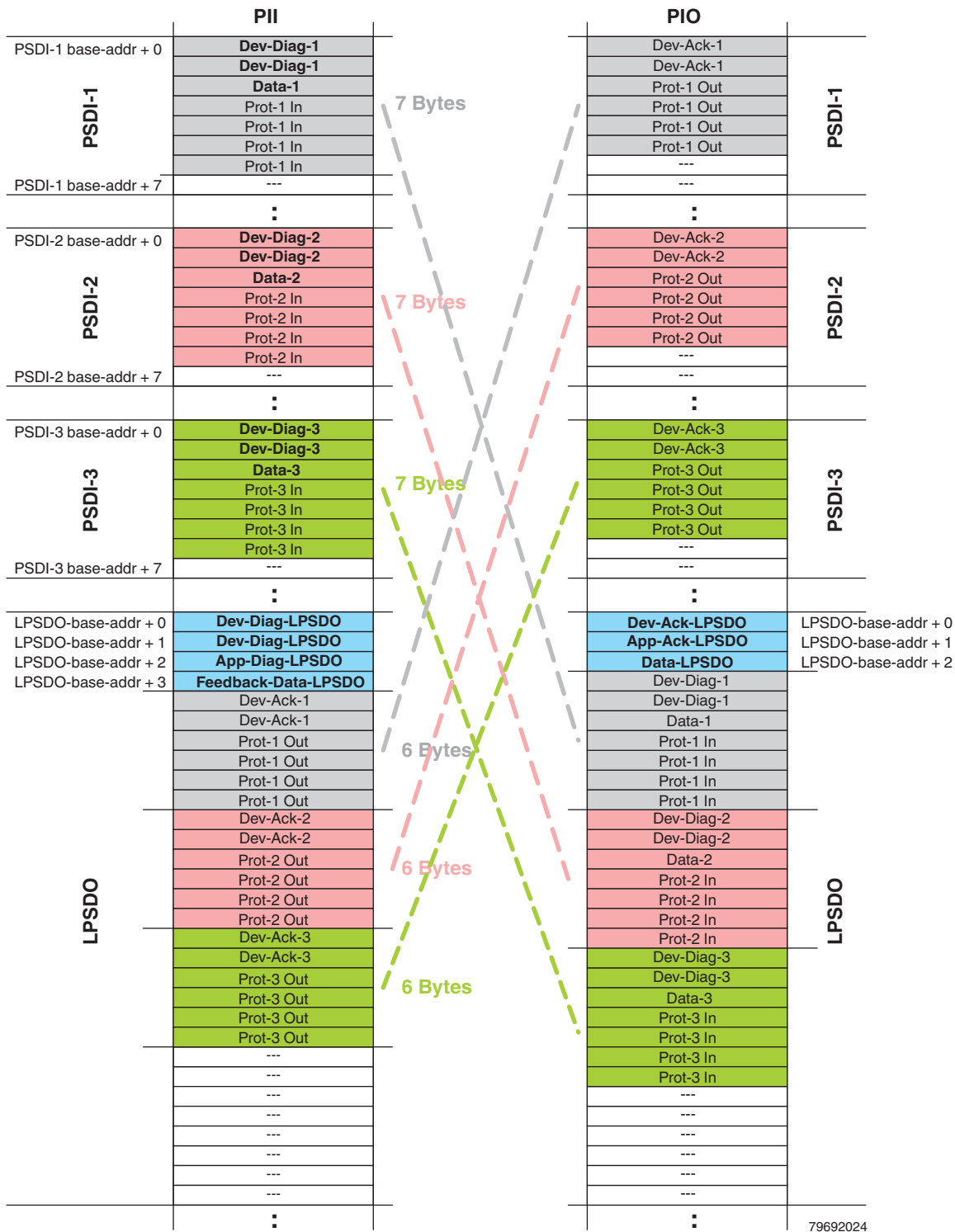

Figure A-4 I/O image and data flow in full configuration

**IB IL 24 LPSDO 8-PAC**

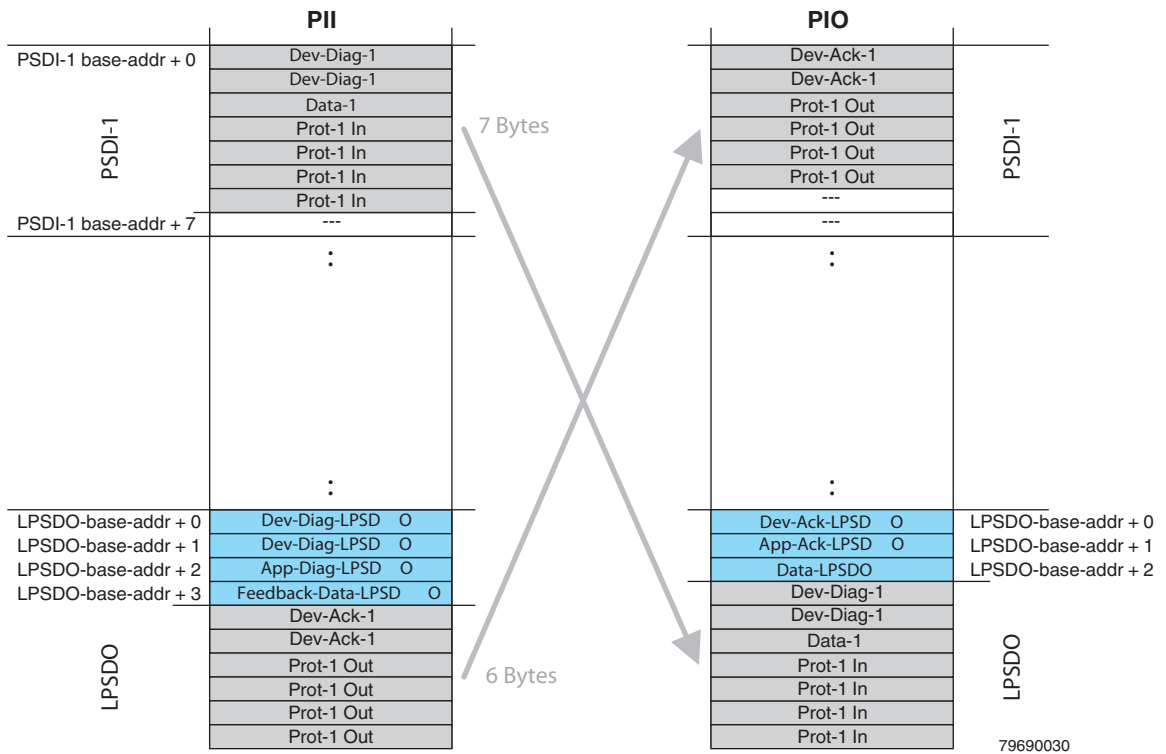

Figure A-5 I/O image and data flow in multiplexer mode

**A 5.2 Descriptions of the registers**

**Data-LPSDO  
(data of the standard control system for the enable function)**

The register contains standard data of the standard control system, which is to enable the IB IL 24 LPSDO 8-PAC. Each bit is assigned to a specific output. The register has the following structure and function:

Table A-13 Data-LPSDO register

7	6	5	4	3	2	1	0
OUT3 _Ch2	OUT3 _Ch1	OUT2 _Ch2	OUT2 _Ch1	OUT1 _Ch2	OUT1 _Ch1	OUT0 _Ch2	OUT0 _Ch1

**Data-x (PSDI)  
(safe data of the IB IL 24 PSDI 8-PAC)**

The register contains the safe data of the specified (x) IB IL 24 PSDI 8-PAC. The register has the following structure and function:

Table A-14 Data-LPSDI register

7	6	5	4	3	2	1	0
IN3 _Ch2	IN3 _Ch1	IN2 _Ch2	IN2 _Ch1	IN1 _Ch2	IN1 _Ch1	IN0 _Ch2	IN0 _Ch1

**Dev-Diag-LPSDO  
(diagnostic LPSDO)**

The diagnostic register of the IB IL 24 LPSDO 8-PAC has the following structure and function:

Table A-15 Dev-Diag register of the IB IL 24 LPSDO 8-PAC

<b>15</b>	<b>14</b>	<b>13</b>	<b>12</b>	<b>11</b>	<b>10</b>	...	<b>0</b>
COK	SA	E	PUR	OAR	Error/address		

Bit		Meaning	Function
15	COK	Communication OK	0: IB IL 24 LPSDO 8-PAC is not parameterized or at least one of the safe communication relationships is not running without any errors.
			1: Communication OK IB IL 24 LPSDO 8-PAC is parameterized and safe communication is running without any errors to all configured remote safe devices. If a remote device is not configured: the IB IL 24 LPSDO 8-PAC is parameterized.
14	SA	Safety address	0: The error message of the IB IL 24 LPSDO 8-PAC is displayed in bits 10 ... 0 together with the error class, number, and location (see "Errors: Messages and removal" on page 8-1).
			1: Firmware startup after power up completed. The set SafetyBridge address is displayed in bits 10 ... 0.
13	E	Device error	0: No error message present at a module.
			1: Group error message: A device or parameterization error or a peripheral fault has been detected in one of the connected IB IL 24 PSDI 8-PAC modules or in the IB IL 24 LPSDO 8-PAC itself. This can be detected via the corresponding Dev-Diag registers of the individual modules.
12	PUR	Power up requested	0: A power up is not expected.
			1: Following an error that cannot be acknowledged, the IB IL 24 LPSDO 8-PAC or one of the satellites expects a power up.
11	OAR	Operator acknowledge requested	0: No request for acknowledgment.
			1: The IB IL 24 LPSDO 8-PAC requests an acknowledgment by the user. Previously: SafetyBridge communication detected an acknowledgeable error that resulted in communication being deactivated.
Bits 10 ... 0		Error code/ address	Bit 14 = 0: The error message of the IB IL 24 LPSDO 8-PAC is displayed in bits 10 ... 0 together with the error class, number, and location (see "Errors: Messages and removal" on page 8-1).
			Bit 14 = 1: The set SafetyBridge address is displayed in bits 10 ... 0.



**OAR:**  
If safe communication is not running to one or more remote safe devices, the OAR bit can indicate that communication can be restored. The user restores communication by means of a positive edge at the OA bit in Dev-Ackn-LPSDO.  
A positive edge at the OA flag acknowledges **all** pending operator acknowledge requests from **all** remote safe devices.

**IB IL 24 LPSDO 8-PAC**



**WARNING: Unexpected machine startup**

If you do not want the machine to start up/restart automatically, configure the safety logic accordingly.

**Dev-Diag-x  
(diagnostic PSDI)**

The diagnostic register of the specified (x) IB IL 24 PSDI 8-PAC has the following structure and function:

Table A-16 Dev-Diag register of the IB IL 24 PSDI 8-PAC

<b>15</b>	<b>14</b>	<b>13</b>	<b>12</b>	<b>11</b>	<b>10</b>	...	<b>0</b>
Diag-Sel			Error code/address				

Bit		Meaning	Function
15 ... 13	Diag-Sel	Diagnostic selector	111 <sub>bin</sub> : Bit 12 has no function Bits 11 ... 0 contain the diagnostic code of the module For the meaning of the diagnostic code, please refer to the user manual for the IB IL 24 PSDI 8-PAC.
			010 <sub>bin</sub> : Bits 12 ... 0 contain the address of the module
			Other: Reserved

**Dev-Ack-LPSDO  
(acknowledgment)**

The register for acknowledging the IB IL 24 LPSDO 8-PAC has the following structure and function:

Table A-17 Dev-Ack register of the IB IL 24 LPSDO 8-PAC

<b>7</b>	<b>6</b>	<b>5</b>	<b>4</b>	<b>3</b>	<b>2</b>	<b>1</b>	<b>0</b>
OA	-	-	-	QE3	QE2	QE1	QE0

Bit		Meaning	Function
7	OA	Operator acknowledge	0 -> 1: Acknowledgment of error message regarding failsafe communication (see also OAR bit in Dev-Diag register).
3 ... 1	QE 3 ... 1	Quit error device 3 ... 1	0 -> 1: Acknowledgment of error message for connected SafetyBridge module (3 to 1) by the user. If another error is present on the corresponding module, it is displayed as the next error.
0	QE0	Quit error device IB IL 24 LPSDO 8-PAC	0 -> 1: Acknowledgment of error message for IB IL 24 LPSDO 8-PAC by the user. If another error is present on the module, it is displayed as the next error.



**OA:**

A positive edge at the OA bit acknowledges **all** pending operator acknowledge requests from **all** remote safe devices.

**Dev-Ack-x  
(device acknowledgment)**

This register is used to acknowledge device errors internally. The user cannot access this register.

**App-Diag-LPSDO  
(application diagnostics)**

The bits in this register can be freely programmed in SAFECONF. Implement diagnostics using these bits.

**App-Diag-x  
(application diagnostics)**

The bits in this register can be freely programmed in SAFECONF. Implement diagnostics using these bits.

**App-Ack-LPSDO  
(application  
acknowledgment for  
IB IL 24 LPSDO 8-PAC)**

The bits in this register can be freely programmed in SAFECONF and can be used for the safety logic. Implement diagnostics using these bits.

**Feedback-Data-LPSDO  
(mirroring)**

The bits in this register mirror the states of the digital outputs. In the event of an error, the mirrored data can differ from the actual state of the outputs. This data is therefore only provided as diagnostic information and must not be used as standard data. The register has the following structure and function:

Table A-18 Feedback-Data register (mirrored data)

7	6	5	4	3	2	1	0
OUT3 _Ch2	OUT3 _Ch1	OUT2 _Ch2	OUT2 _Ch1	OUT1 _Ch2	OUT1 _Ch1	OUT0 _Ch2	OUT0 _Ch1

**Prot-x**

Protocol data. The user cannot access this register.

### A 5.3 Mirroring of local safe output data

So that the state of the local safe outputs of a safe output module is visible in the standard control system without additional configuration and parameterization effort, in each safe output module of the SafetyBridge system this state is mirrored automatically in the standard input data (see also "Programming data/configuration data" on page 2-11).

## A 6 Implementation of data flow between the standard control system and the safety modules

For the required parallel communication between the safe components, data flow must be ensured by the relevant standard control system. Consistency must therefore be ensured over the entire data width of the safe devices.



If data consistency is not ensured, the module shuts down and requests an operator acknowledgment.

Data flow within standard infrastructure components is not safety-related. The safeguarding measures for failsafe communication are implemented in the safe termination devices.

### A 6.1 Implementation of data flow with a function block

A copy function block (COPY FB) is available from Phoenix Contact for certain systems. It is used to ensure data flow between the SafetyBridge modules.

### A 6.2 Implementation of data flow without a function block

If a function block (COPY FB) is not available for your controller, you must implement data flow within the SafetyBridge system yourself.

With a special I/O structure in the process image, the SafetyBridge components represent the higher-level control system. The structure is mapped to the relevant device description.

The components illustrated in Figure A-4 must be copied according to the arrows for the required data flow between the SafetyBridge components. The data/registers in bold are also useful for the standard application program of the standard control system.

## A 7 Enable principle

The enable principle is implemented in the SafetyBridge system. For this, all modules with local outputs have an enable function integrated in the device firmware (ANDed bit-by-bit) for each local safe output channel. The enable function can be parameterized (enabled/disabled) for each specific channel.

When the enable function is enabled, the relevant safe local output is ANDed bit-by-bit with the corresponding standard output of the standard control system (Data-LPSDO register). This output is then only set if the result of the safety function calculation permits this and the standard control system has set the corresponding output in the Data-LPSDO register (see also "I/O image and data flow in full configuration" on page A-13).

The enable function is performed according to the single-channel or two-channel parameterization of the safe outputs.

The enable function cannot be used in multiplexer mode.



The enable function is not graphically represented in SAFECONF in the safety logic editor. Parameterize the enable function when parameterizing the channels.

The following figure illustrates the enable principle.

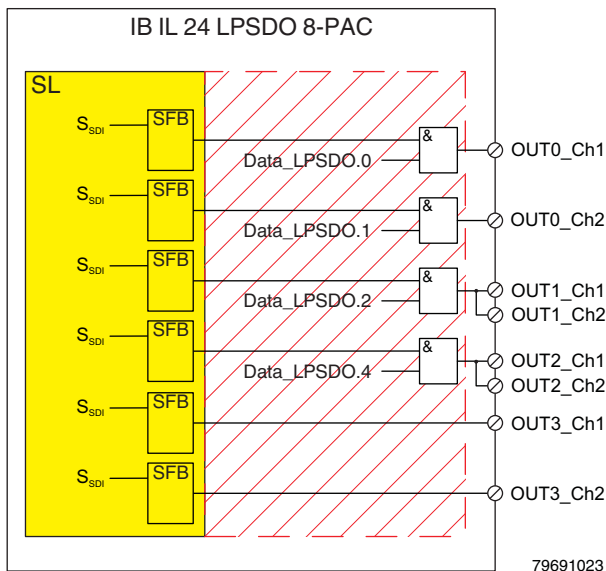

Figure A-6 Enable principle (example)

- SL Safety logic
- SFB Safe function block
- & Standard function block for ANDing
- S<sub>SDI</sub> Signal from the IB IL 24 PSDI 8-PAC safe input module
- Data-LPSDO.x Standard data of the standard control system, which is to acknowledge the IB IL 24 LPSDO 8-PAC; bit x
- OUT<sub>x</sub>\_Ch<sub>y</sub> Output x, channel y
- Internal sequences

Table A-19 Parameterization of output channels for the example in Figure A-6

Output/channel	Output	Enable function
OUT0_Ch1	Single-channel	Enabled
OUT0_Ch2	Single-channel	Enabled
OUT1_Ch1	Two-channel	Enabled
OUT1_Ch2	Two-channel	Enabled
OUT2_Ch1	Two-channel	Enabled
OUT2_Ch2	Two-channel	Enabled
OUT3_Ch1	Single-channel	Disabled
OUT3_Ch2	Single-channel	Disabled

## A 8 Diagnostics

In addition to precise diagnostics for the standard bus system, peripheral faults and device errors can also be detected by the safe input and output devices.

### A 8.1 Error detection in I/O devices

#### Safe inputs

Depending on the device type and parameterization, the following errors can be detected at safe inputs:

- Short circuit
- Cross circuit
- Overload/short circuit of the clock outputs

If an error is detected at an input, the safe state is set for this input and a "0" is transmitted in the input data of the input ("0" = safe state).

The corresponding error message is transmitted to the IB IL 24 LPSDO 8-PAC and the standard control system.



For more detailed information about error detection at the safe inputs, please refer to the user manual for the IB IL 24 PSDI 8-PAC.

#### Safe outputs

Depending on the device type and parameterization, the following errors can be detected at safe outputs:

- Short circuit
- Cross circuit
- Overload
- Violation of the shutdown time

If an error is detected at an output, the affected output is disabled ("0" = OFF = safe state).

The corresponding error message is transmitted to the IB IL 24 LPSDO 8-PAC and the standard control system.

### A 8.2 Detection of device errors

All serious errors that can result in the loss of or adversely affect the safety function cause the entire device to enter the safe state. The FS LED on the safe device is permanently on.

Depending on the device type, the following errors lead to the safe state:

- Hardware fault in the circuit
- User error
- Module overload
- Overheating
- Faulty supply voltage

The corresponding error message is transmitted to the IB IL 24 LPSDO 8-PAC and the standard control system.



To determine which errors are detected by a specific device, please refer to the corresponding device documentation.

### A 8.3 Acknowledgment of error messages for remote modules (satellites)

Errors that occur on satellites are acknowledged by the standard control system in the Dev-Ack-LPSDO register on the IB IL 24 LPSDO 8-PAC (see "Descriptions of the registers" on page A-14). The acknowledgment is forwarded to the satellites.



An example for the acknowledgment of error messages can be found in the Quick Start Guide for the IB IL 24 LPSDO 8-PAC (see "Ordering data: Documentation" on page 10-7).

## A 9 Configuration, parameterization, and download



An example for configuration, parameterization, and download can be found in the Quick Start Guide for the IB IL 24 LPSDO 8-PAC (see "Ordering data: Documentation" on page 10-7).

### A 9.1 Configuration and parameterization using the SAFECONF tool

The SAFECONF software tool is available to users for configuring the safety logic and parameterizing the channels of the safety modules used. Configuration and parameterization can be carried out offline, without connecting to the safety modules.

#### Configuration

During configuration, select the modules, set the switches, and connect the safety function in SAFECONF.

#### Parameterization

To parameterize the system, parameterize each input and output of the system.

#### Configuration and parameterization data record

The safe configuration and parameterization user interface of SAFECONF generates a data record with the configuration and parameterization data for all the modules of a SafetyBridge island in the format specific to the controller. So that data consistency and uniqueness can be checked, suitable means such as addresses, module IDs, and CRCs are included in the configuration and parameter record.

Import this configuration and parameter data record in the standard control system used according to the controller.

On every power up, make this data record available to the IB IL 24 LPSDO 8-PAC island node (see "Downloading the configuration and parameter data record following power up" on page A-22). The IB IL 24 LPSDO 8-PAC module is thus parameterized. The satellites are parameterized automatically by the IB IL 24 LPSDO 8-PAC module.

## IB IL 24 LPSDO 8-PAC

SAFECONF can be used as a stand-alone tool. Depending on the control system, calling SAFECONF can also integrate the transfer of the configuration and parameter record deeper into the relevant control system.



Online help is available for the SAFECONF software tool.



SAFECONF should also be used in the planning phase. If the size of the configuration and parameterization data record for the planned safety functions exceeds the memory size, an error message is displayed and changes can be made at an early stage.

To roughly estimate the memory required, please use the information in "Memory sizes for the safety logic" on page A-31.

### A 9.2 Downloading the configuration and parameter data record following power up

The entire configuration and parameterization can be created offline with SAFECONF. First, in order to download the system must be fully installed. Communication must be running when transmitting the data record.



#### **WARNING: Loss of safety function**

Before downloading a data record, check whether the current data record will actually be loaded.

Make sure that the data record on the IB IL 24 LPSDO 8-PAC is not overwritten with an old data record. Information about a data record is provided in the project header.

During startup, do not configure a delete service for a configuration and parameter data record. Before overwriting a data record, always read back the project header first.



Make sure that you are sending the correct data record to the correct IB IL 24 LPSDO 8-PAC. If a data record is sent to an IB IL 24 LPSDO 8-PAC that was not specified, an error message appears in the diagnostic register of the IB IL 24 LPSDO 8-PAC.



For selected controllers, function blocks are available for download.

### A 9.3 Implementing modular system concepts

In the SafetyBridge system, it is possible to handle modular system concepts with different system configurations. This is possible by dividing the entire configuration and parameter data record into an address-independent part and one or more address-dependent parts.

The address-independent parts contains the logic and channel parameterizations of the devices that belong to an island. It is referred to below as the logic block.

The address-dependent part contains the unique project header and the island configuration including all connection information.

Figure A-7 shows an example in which two islands (1 and 3) are assigned to project A and island 2 is assigned to project B.

The assignment of two islands (IB IL 24 LPSDO 8-PAC + connected IB IL 24 PSDI 8-PAC) to a project is only possible if the safety logic and the channel parameterization within both islands are exactly the same. The only difference between the islands is the island number (address of the IB IL 24 LPSDO 8-PAC).

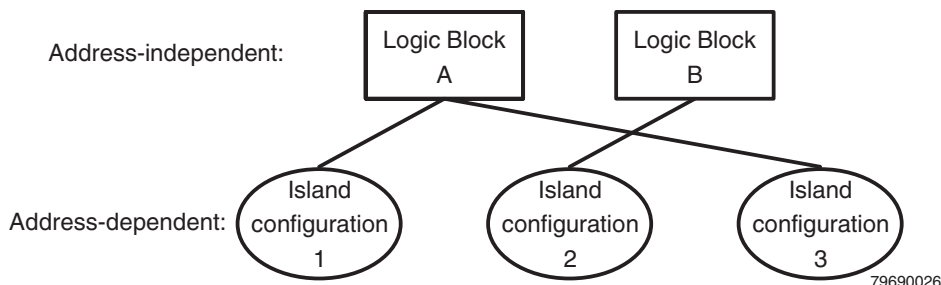

Figure A-7 Example for assigning projects

- Separation of configuration/parameterization and addresses
- Modular combination supported by the controller, e.g.,:

Island	Project
1	A
2	B
3	A

The standard control system transmits to a concrete IB IL 24 LPSDO 8-PAC, then to an address-independent part (e.g., project A) and the address-dependent part (e.g., island 1) that is specific to the IB IL 24 LPSDO 8-PAC.



An example for importing data can be found in the Quick Start Guide for the IB IL 24 LPSDO 8-PAC (see "Ordering data: Documentation" on page 10-7).

## A 10 Safe state

The safe state:

- For safe output devices, the safe state is the power off state at the affected output terminals.
- For safe input devices, the safe state is the transmission of the "safe state value" ("0") in the image of the affected inputs to the safe standard control system.
- For transmission on the bus, the safe state is the transmission of the value "0".

The safe state can be a normal operating state or is set if a corresponding error has been detected.

## A 11 Time response in the SafetyBridge system

In the planning phase of the machine/system and the SafetyBridge system, specify the required shutdown time for each safety function. This is ascertained on the basis of the safety evaluation of the machine/system, taking into consideration the safety distances and the approach speed. Please observe the applicable standards and regulations.

In the planning phase of the planned SafetyBridge system, calculate the shutdown time for the outputs.

For each safety function, check whether, in conjunction with all other components, the calculated shutdown time is sufficient to observe the required shutdown time for the safety function.

The aim of the calculations is to ensure that the safety function responds within the required time.

### A 11.1 Typical response time

The typical response time of the SafetyBridge system is the time that elapses from the signal being applied at the safe input terminal through to the response at the safe output terminal. This time can usually only be achieved and measured during error-free operation of the SafetyBridge system.

The typical response time of the SafetyBridge system is not relevant and not suitable for designing safety distances.

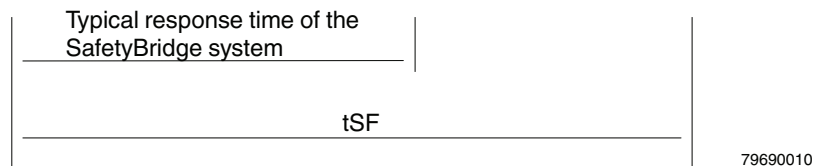

Figure A-8 Typical response time and required shutdown time for the safety function

Table A-20 Key for formula and Figure A-9

Abbreviation	Meaning	Note
$t_{SF}$	Required shutdown time for the safety function	Determined from the application, e.g., from the required times according to the distance of a light grid



The typical response time depends on the network and standard control system used.

## A 11.2 Shutdown time

The **required** shutdown time for the safety function is based on the response times of the sensors used, the SafetyBridge system, the actuator used, and the stopping time. The required shutdown time of the safety function can be determined from the safety distances or the safety distances are defined based on the determined guaranteed shutdown time.

The **guaranteed** shutdown time for the safety function is based on the longest processing time of the safe inputs involved in the safety function and the shutdown time of the safe output (single or two-channel) involved.

For the processing time of the safe inputs, please refer to the corresponding data sheets for the safe input devices.

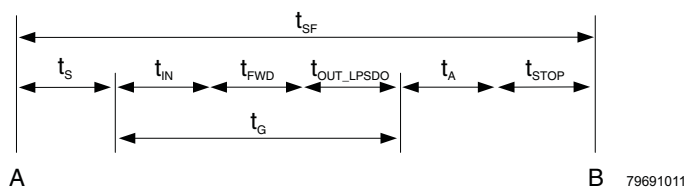

Figure A-9 Overview of the shutdown times

This results in the following formula for  $t_{SF}$

$$t_{SF} = t_S + t_{IN} + t_{FWD} + t_{OUT\_LPSDO} + t_A + t_{STOP}$$

Table A-21 Key for formula and Figure A-9

Abbreviation	Meaning	Note
A	Demand of the safety function	
B	Safe state of the system	
$t_{SF}$	Required shutdown time for the safety function	Determined from the application, e.g., from the required times according to the distance of a light grid
$t_S$	Response time of the sensor	Data sheet of the sensor
$t_{IN}$	Processing time of the input	User manual of the safe input module
$t_{FWD}$	F-Watchdog time (communication)	Specified by the user in SAFECONF for each IB IL 24 PSDI 8-PAC module
$t_{OUT\_LPSDO}$	Shutdown time of the IB IL 24 LPSDO 8-PAC	20 ms; see technical data "SafetyBridge system" on page 10-1
$t_A$	Response time of the actuator	Data sheet of the actuator
$t_{STOP}$	Machine stopping time	Measurement
$t_G$	Guaranteed shutdown time	Calculation: $t_G = t_{IN} + t_{FWD} + t_{OUT\_LPSDO}$



Fluctuations in network communication and in the copy routines (e.g., including controller STOP) result in safe communication being aborted.

**IB IL 24 LPSDO 8-PAC**

---

**t<sub>FWD</sub>**

The F-Watchdog time (t<sub>FWD</sub>) is specified for each communication relationship in SAFECNF.

The minimum achievable t<sub>FWD</sub> depends on the network and controller (see documentation for the controller used).



Please note when specifying the F-Watchdog time, future system expansions can affect the F-Watchdog time.

Within t<sub>FWD</sub>, the standard network and the standard control system must be able to transmit telegrams from satellites to the IB IL 24 LPSDO 8-PAC.

**t<sub>S</sub>, t<sub>IN</sub>**

If **several sensors** are involved in the safety function, the longest response time of the sensors involved influences the calculation.

If **several inputs** are involved in the safety function, the longest processing time of the inputs involved influences the calculation.

If **several IB IL 24 PSDI 8-PAC** devices are involved in a safety function, the longest F-Watchdog time is influential.

## A 12 Achievable safety depending on the modules used

To specify the PL, in theory the PL for each safety chain must be specified. According to EN ISO 13849-1 a simplified approach is possible: If the entire island is involved in the safety function, the entire island can be considered as one device.

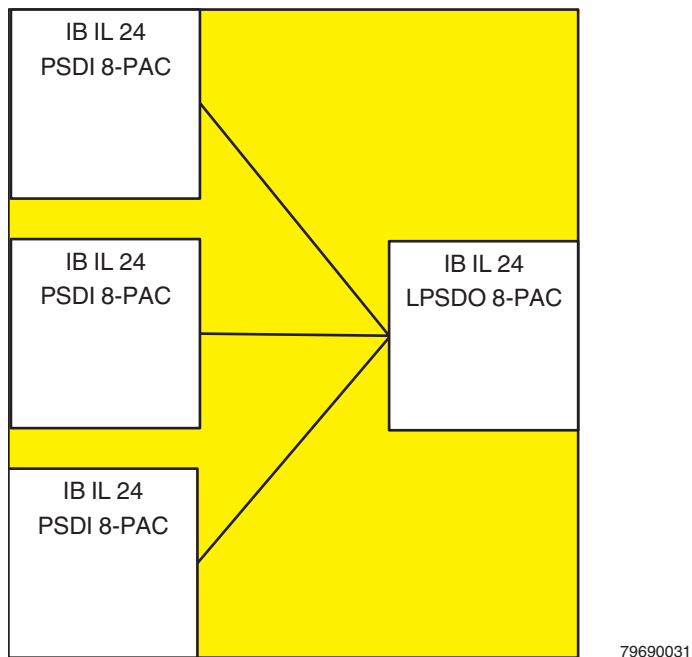

Figure A-10 Considering the island as one device

The table shows the achievable safety of the islands involved in the safety function as one device.

Table A-22 Achievable safety depending on the modules used - considered as one device

Input modules	Output modules	Maximum achievable PL	
IB IL 24 PSDI 8-PAC	IB IL 24 LPSDO 8-PAC	MTTFd for system	PL for the system
<b>Single-channel</b>			
3	1	22 years	PL d
<b>Two-channel</b>			
3	1	30 years	PL e

**IB IL 24 LPSDO 8-PAC**

---

The achievable safety always depends on the parameterization and wiring of the individual components.

**Output module:**

- Parameterize the output module according to "Parameterization of the safety module" on page 5-1.
- Observe the information in the connection examples for the output module (see 6, "Connection examples for safe outputs").
- Observe the requirements of the standards with regard to the external wiring and the actuators to be used to achieve a PL (see "Measures required to achieve a specific safety integrity level" on page 6-3).

**Input modules:**

- Observe the information in the **UM EN IB IL 24 PSDI 8-PAC** user manual.
- Parameterize the input modules according to the "Parameterization of the safety module" section.
- Observe the information in the connection examples for the input modules (see "Connection examples for safe inputs").
- Observe the requirements of the standards with regard to the external wiring and the sensors to be used to achieve a PL (see "Measures required to achieve a specific safety integrity level").

## A 13 Behavior in the event of an error

### Error messages

Errors that occur on the safe devices can be detected using the process data, function blocks, and device LEDs.

These error messages can be evaluated in the standard application program or can be displayed by means of a visualization.



For instructions on how to proceed in the event of an error, please refer to "Acknowledging an error" on page 8-9.

### Service information

In addition to error messages, service information can also be output. This information takes the form of device message warnings that do not affect the safety function. These warnings are either unacknowledged messages or messages that are acknowledged via the controller.

### Error classes

The response of all devices connected to the system and the safety functions to an error depends on the error class detected.

There are three different error classes in the SafetyBridge system:

- Critical system and device errors
- Parameterization and configuration errors
- Peripheral faults

A distinction is made between the following:

- The severity of the error
- The reciprocal effects on other components in the system
- The acknowledgment and restart options

### Acknowledgment

The acknowledgment of an error is an intentional user action (controlled via the standard application program) with the aim of showing the system (or subsystem) that an error has been removed and that the system (or subsystem) can reactivate the faulty component.

Errors in a SafetyBridge island are acknowledged via the acknowledgment register of the IB IL 24 LPSDO 8-PAC (see "Dev-Ack-LPSDO (acknowledgment)" on page A-16).

### A 13.1 Critical system or device errors

All errors that are detected and immediately switch the device to the failure state are assigned to this class.

These include:

- Hardware faults (detected by selftests within devices)
- Parameterization and configuration data errors (detected via the CRC)
- Control flow/program sequence errors within the firmware of a device

Errors in this class are usually errors within the system, hardware or firmware, which were not caused by the user and cannot be removed (device-specific exceptions are possible).

It is not possible to acknowledge the error or continue operating. The affected devices can only be restarted via a voltage reset. If the power on selftests are successful following a restart, the system can continue to operate.

### A 13.2 Parameterization or configuration errors

All errors that are detected during the plausibility check of parameters and configuration data are assigned to this class. This is usually carried out during the initialization phase of the system. Following the detection of an error in this class, the devices enter the safe state and are still able to send diagnostic information or receive new parameter or configuration data.

It is not possible to acknowledge the error or continue operating without modifying the parameter or configuration data of the affected device. The affected devices can only be restarted via a voltage reset. If the power on selftests are completed successfully following a restart, the system can continue to operate.

### A 13.3 Communication errors

Errors detected in the safe protocol during network communication can lead to "operator acknowledge requested" (acknowledgement by the user; see "Dev-Diag-LPSDO (diagnostic LPSDO)" on page A-15). For example, these include:

- Transmission errors
- Data consistency when copying
- Set  $t_{FWD}$  is incorrect (the network is too slow for the set  $t_{FWD}$ )
- Standard control system is in the stop state

These errors can be acknowledged. Do not acknowledge these errors from the application program. Acknowledgment must be triggered by an intentional user action.

### A 13.4 Peripheral faults

All errors that can occur and be detected within the I/O devices connected to the safe I/O devices are assigned to this class. For example, these include:

- Short/cross circuits at the inputs or outputs
- Other application-specific errors

These errors are usually detected in the operating phase of the system. When an error is detected, the affected input or output is disabled and a diagnostic message is sent to the IB IL 24 LPSDO 8-PAC and the standard control system. The standard system is ready to operate again. Continuous operation of the application depends on the actual application.

Peripheral faults can be acknowledged individually by the user in the standard application program.

The affected output is not disabled if the following errors are detected:

- The permissible bouncing time of an input signal is exceeded
- The permissible simultaneity of two input signals is exceeded (parameterization: start inhibit due to symmetry violation is disabled)

In this case, only one diagnostic message is generated.

---

## A 14 Startup and restart

### A 14.1 Startup/restart following power up

Following successful download of the configuration and parameterization data record as well as successful processing of the internal tests, the module continues running.

**WARNING: Unexpected machine startup**

If you do not want the machine to start up/restart automatically, configure the safety logic accordingly.

### A 14.2 Restart after triggering a safety function

The SafetyBridge system automatically resets a safety-related output to "1" if the source of the safety function is reset.

**WARNING: Unexpected machine startup**

If you do not want the machine to restart automatically, configure the safety logic accordingly.

## A 15 Memory sizes for the safety logic

The size of the safety logic may be a maximum of 5000 bytes.

The following guide values can be used as a basis for creating your safety logic:

- Size of each block used for the first time: 800 bytes
- Size of each additional instance: 300 bytes
- In the mix calculation, both of these values include a reserve for various other logic operations (AND, OR, NOT, etc.).

For the actual size of the data record, please refer to SAFECONF. If the safety logic limit has been exceeded, a corresponding error message is displayed by SAFECONF. In this case, reduce your safety logic.

## B Appendix: Checklists

The checklists listed in this section provide support during the planning, assembly and electrical installation, startup, parameterization, and validation of the IB IL 24 LPSDO 8-PAC module.



These checklists may be used as planning documentation and/or as verification to ensure the steps in the specified phases are carried out carefully.

Archive the completed checklists to use as reference for recurring tests.

The checklists do not replace the validation, initial startup, and regular testing performed by qualified personnel.

The following section of a checklist shows an example of a completed checklist.

Checklist . . .				
<b>Device type/equipment identification</b>			IB IL 24 LPSDO 8-PAC/BK20NA10	
<b>Version: HW/FW/FW</b>	00/100/100		<b>Date</b>	October 2, 2009
<b>Test engineer 1</b>	John Smith		<b>Test engineer 2</b>	Jane Brown
<b>Remark</b>	System XXX has been checked for engine hood production			
<b>No.</b>	<b>Requirement (mandatory)</b>	<b>Yes</b>		<b>Remark</b>
X	...	<input type="checkbox"/>		
<b>No.</b>	<b>Requirement (optional)</b>	<b>Yes</b>	<b>No</b>	<b>Remark</b>
Y	...	<input type="checkbox"/>	<input type="checkbox"/>	

Key:

Equipment identification	Enter the device type and/or the equipment identification for the relevant device.
Version: HW/FW/FW	Enter the hardware and firmware version of the device (see "Structure of the safety module" on page 2-2).
Date	Enter the date on which you began to fill in this checklist.
Test engineer 1/2	Enter the names of the test engineers.
Remark	Enter a remark, if necessary.
Requirement (mandatory)	These requirements must be met for a safety application, in order to complete the relevant phase using the checklist.
Requirement (optional)	These requirements are optional. For points that are not met, please enter an appropriate remark in the relevant field.

## IB IL 24 LPSDO 8-PAC

**B 1 Checklists for the SafetyBridge system****B 1.1 Planning**

Checklist for planning the use of the SafetyBridge system			
<b>Equipment identification</b>			
		<b>Date</b>	
<b>Test engineer 1</b>		<b>Test engineer 2</b>	
<b>Remark</b>			
No.	Requirement (mandatory)	Yes	Remark
1	Has a hazard and risk analysis been carried out for the system/machine?	<input type="checkbox"/>	
2	Has the corresponding safety integrity level (SIL, SIL CL, Cat., PL) been derived from the hazard and risk analysis?	<input type="checkbox"/>	
3	Does the SafetyBridge system meet the required safety integrity level?	<input type="checkbox"/>	
4	Has the current IB IL 24 LPSDO 8-PAC user manual been used as the basis for planning?	<input type="checkbox"/>	Revision:
5	Has the voltage supply been planned according to the specifications for the protective extra-low voltage in accordance with PELV?	<input type="checkbox"/>	
6	Are safety distances that must be observed calculated according to the response and delay times implemented?	<input type="checkbox"/>	
7	Has the required shutdown time for safety function $t_{SF}$ resulting from the machine/system design been determined?	<input type="checkbox"/>	$t_{SF}$ :
8	Can the planned application be implemented with the configuration options (e.g., by using function blocks)?	<input type="checkbox"/>	
9	Does the planned use correspond to the intended use of the system?	<input type="checkbox"/>	
10	Has the technical data of the SafetyBridge system been observed?	<input type="checkbox"/>	
11	Is it ensured that in an overall system comprising the SafetyBridge system and any higher-level PROFIsafe system, the addresses (address within the SafetyBridge system and F-Address of the PROFIsafe system) are unique?	<input type="checkbox"/>	
12	Within a SafetyBridge system, is each island number only assigned once?	<input type="checkbox"/>	
13	Is the application stop (OFF, STOP, emergency stop, triggering of safety equipment) implemented according to EN 60204?	<input type="checkbox"/>	
14	When planning the safety functions, has the SAFECONF software tool been used to determine whether the memory space is sufficient for the size of the safety logic?	<input type="checkbox"/>	
15	Has it been ensured that any person intentionally starting hazardous movements has a direct view of the danger zone?	<input type="checkbox"/>	

No.	Requirement (optional)	Yes	No	Remark
16	Are all measures that are based on applicable standards planned?	<input type="checkbox"/>	<input type="checkbox"/>	
17	Have the Inline specifications (e.g., cabling, power supply) been observed?	<input type="checkbox"/>	<input type="checkbox"/>	
18	Have the accessories to be used been planned (e.g., cables, connectors)?	<input type="checkbox"/>	<input type="checkbox"/>	
19	Is the transmission speed for the individual Inline stations specified?	<input type="checkbox"/>	<input type="checkbox"/>	
20	Are the specifications for parameterization, assembly, electrical installation, startup, and validation of the IB IL 24 LPSDO 8-PAC described?	<input type="checkbox"/>	<input type="checkbox"/>	
21	Are the specifications for parameterization, assembly, electrical installation, startup, and validation of the satellites described?	<input type="checkbox"/>	<input type="checkbox"/>	
22	Is the assignment of responsibility specified (e.g., for assembly/installation/configuration, parameterization/startup/validation, etc.)?	<input type="checkbox"/>	<input type="checkbox"/>	Name/company:
23	Are measures planned which prevent hazardous states in each phase (e.g., specification of individual steps in the procedure for each phase)?	<input type="checkbox"/>	<input type="checkbox"/>	
24	Is monitoring of the actuators and sensors controlled/requested by the SafetyBridge system planned (e.g., reading of outputs)?	<input type="checkbox"/>	<input type="checkbox"/>	
		Date		Signature (test engineer 1)
		Date		Signature (test engineer 2)

## IB IL 24 LPSDO 8-PAC

## B 1.2 Configuration and parameterization

Checklist for configuration and parameterization of the SafetyBridge system				
Equipment identification				
		Date		
Test engineer 1		Test engineer 2		
Remark				
No.	Requirement (mandatory)	Yes	Remark	
1	Has the safety logic been configured?	<input type="checkbox"/>		
2	Have all inputs and outputs been fully and correctly parameterized?	<input type="checkbox"/>		
3	Are standard input signals exclusively used to configure standard operations (e.g., for the enable principle using the EN_OUT block or for acknowledgment)?	<input type="checkbox"/>		
4	Has it been ensured that in the overall system comprising SafetyBridge and any higher-level PROFIsafe system, the addresses (address within the SafetyBridge system and F-Address of the PROFIsafe system) are unique?	<input type="checkbox"/>		
5	Has watchdog time $t_{FWD}$ been set for each satellite according to the application?	<input type="checkbox"/>		
6	Has the correct terminal point been assigned to the correct signal?	<input type="checkbox"/>		
7	Is the island address set correctly?	<input type="checkbox"/>		
8	For IB IL 24 LPSDO 8-PAC outputs that are parameterized for two-channel operation, are both channels parameterized correctly for each other?	<input type="checkbox"/>		
9	For remote module inputs that are parameterized for two-channel operation, are both channels parameterized correctly for each other?	<input type="checkbox"/>		
10	Has the switch-off delay for stop category 1 been observed in the calculation of the total response time for the machine/system?	<input type="checkbox"/>		
11	Has prevention of undesired startup/restart been configured?	<input type="checkbox"/>		
12	Is it ensured that an operator acknowledgment is only executed by an intentional user action? (Not configured as "automatic")	<input type="checkbox"/>		
13	Has the checklist/project information been processed in SAFECONF ("Project... Project Info" menu item)?	<input type="checkbox"/>		
No.	Requirement (optional)	Yes	No	Remark
14		<input type="checkbox"/>	<input type="checkbox"/>	
		Date	Signature (test engineer 1)	
		Date	Signature (test engineer 2)	

### B 1.3 Startup

Checklist for startup of the SafetyBridge system				
<b>Equipment identification</b>				
		<b>Date</b>		
<b>Test engineer 1</b>		<b>Test engineer 2</b>		
<b>Remark</b>				
No.	Requirement (mandatory)	Yes		Remark
1	During startup, has it been ensured that any person starting hazardous movements intentionally can only do so with a direct view of the danger zone?	<input type="checkbox"/>		
No.	Requirement (optional)	Yes	No	Remark
2	Are startup specifications applicable?	<input type="checkbox"/>	<input type="checkbox"/>	
3	If applicable, have startup specifications been met?	<input type="checkbox"/>	<input type="checkbox"/>	
		Date		Signature (test engineer 1)
		Date		Signature (test engineer 2)

### B 1.4 Safety functions

Enter all the safety functions for your application in this checklist.

Checklist for checking safety functions			
Equipment identification			
		Date	
Test engineer 1		Test engineer 2	
Remark			
No.	Safety functions	Yes	Remark
1		<input type="checkbox"/>	
2		<input type="checkbox"/>	
3		<input type="checkbox"/>	
4		<input type="checkbox"/>	
5		<input type="checkbox"/>	
6		<input type="checkbox"/>	
7		<input type="checkbox"/>	
8		<input type="checkbox"/>	
9		<input type="checkbox"/>	
10		<input type="checkbox"/>	
11		<input type="checkbox"/>	
12		<input type="checkbox"/>	
13		<input type="checkbox"/>	
14		<input type="checkbox"/>	
15		<input type="checkbox"/>	
16		<input type="checkbox"/>	
		Date	Signature (test engineer 1)
		Date	Signature (test engineer 2)

## B 1.5 Validation

Checklist for validating the SafetyBridge system				
<b>Equipment identification</b>				
		<b>Date</b>		
<b>Test engineer 1</b>		<b>Test engineer 2</b>		
<b>Remark</b>				
No.	Requirement (mandatory)	Yes	Remark	
1	Have the mandatory requirements for planning been met?	<input type="checkbox"/>		
2	If applicable, have the mandatory requirements for startup been met?	<input type="checkbox"/>		
3	Has validation of the safe devices used been carried out and are the results available?	<input type="checkbox"/>		
4	Are safety distances that must be observed calculated according to the response and delay times implemented?	<input type="checkbox"/>		
5	Have all the safety functions been checked successfully?	<input type="checkbox"/>		
6	Do all the islands in the system have different island addresses?	<input type="checkbox"/>		
7	Has it been ensured that in the overall system comprising SafetyBridge and any higher-level PROFIsafe system, the addresses (address within the SafetyBridge system and F-Address of the PROFIsafe system) are unique?	<input type="checkbox"/>		
8	Has the SAFECONF project been printed with the project information (name, CRC, time stamp, etc.)?	<input type="checkbox"/>		
9	Has the CRC of the SAFECONF project printout been compared with the CRC of the loaded project header and do they match?	<input type="checkbox"/>		
No.	Requirement (optional)	Yes	No	Remark
10	Are the directives and standards used listed in the declaration of conformity?	<input type="checkbox"/>	<input type="checkbox"/>	
11	Has the safety logic created in SAFECONF been packed and archived? Enter the archiving location (e.g., drive or cabinet) in the "Remark" column.	<input type="checkbox"/>	<input type="checkbox"/>	
12	Has a complete printout of the safety logic configured in SAFECONF been stored for the system?	<input type="checkbox"/>	<input type="checkbox"/>	
13	Have all fully completed checklists been stored for the system?	<input type="checkbox"/>	<input type="checkbox"/>	
		Date		Signature (test engineer 1)
		Date		Signature (test engineer 2)

## IB IL 24 LPSDO 8-PAC

**B 2 Checklists for the IB IL 24 LPSDO 8-PAC module****B 2.1 Planning**

Checklist for planning the use of the safety module			
Device type/equipment identification			
Version: HW/FW/FW		Date	
Test engineer 1		Test engineer 2	
Remark			
No.	Requirement (mandatory)	Yes	Remark
1	Has the current module user manual been used as the basis for planning?	<input type="checkbox"/>	Revision:
2	Does the planned use correspond to the intended use?	<input type="checkbox"/>	
3	Has the technical data of the module been observed?	<input type="checkbox"/>	
4	Are the actuators approved for connection to the module (according to the technical data and parameterization options)?	<input type="checkbox"/>	
5	Has the voltage supply been planned according to the specifications for the protective extra-low voltage in accordance with PELV?	<input type="checkbox"/>	
6	Has the power supply of $U_M$ and $U_S$ from a power supply unit been planned?	<input type="checkbox"/>	
7	Is external fuse protection of the module planned (according to the specifications in this user manual for supply voltage $U_M$ )?	<input type="checkbox"/>	
8	Is use in a control cabinet (IP54) planned?	<input type="checkbox"/>	
9	Are measures planned to prevent simple manipulation?	<input type="checkbox"/>	
10	Are measures planned to prevent connectors being mixed up?	<input type="checkbox"/>	
11	Are requirements for the actuators and cable installation observed according to the SIL/SIL CL/Cat./PL to be achieved and is the corresponding implementation planned?	<input type="checkbox"/>	
12	Are the specifications for the address assignment for the islands specified?	<input type="checkbox"/>	
13	Are the specifications for the parameterization for each channel specified?	<input type="checkbox"/>	
14	Are test intervals specified for testing the shutdown capability of the actuators, if this is required to achieve a SIL/SIL CL/Cat./PL?	<input type="checkbox"/>	
15	Has it been ensured that any person intentionally starting hazardous movements has a direct view of the danger zone?	<input type="checkbox"/>	
16	Have test intervals been defined?	<input type="checkbox"/>	
17	Has the switch-off delay for stop category 1 been observed in the calculation of the total response time for the machine/system?	<input type="checkbox"/>	

No.	Requirement (optional)	Yes	No	Remark
18	Have specifications for assembly and electrical installation been defined (e.g., EPLAN) and communicated to the relevant personnel?	<input type="checkbox"/>	<input type="checkbox"/>	
19	Have specifications for startup been defined and communicated to the relevant personnel?	<input type="checkbox"/>	<input type="checkbox"/>	
		Date		Signature (test engineer 1)
		Date		Signature (test engineer 2)

IB IL 24 LPSDO 8-PAC

**B 2.2 Assembly and electrical installation**

Checklist for assembly and electrical installation of the safety module				
<b>Device type/equipment identification</b>				
<b>Version: HW/FW/FW</b>		<b>Date</b>		
<b>Test engineer 1</b>		<b>Test engineer 2</b>		
<b>Remark</b>				
No.	Requirement (mandatory)	Yes	Remark	
1	Was assembly and installation completed according to the specifications (specifications from the planning phase or according to the user manual)?	<input type="checkbox"/>		
2	Was the safety module installed in the control cabinet (IP54)?	<input type="checkbox"/>		
3	Do the cable cross-sections correspond to the specifications?	<input type="checkbox"/>		
4	Are requirements for the actuators and cable installation observed according to the SIL/SIL CL/Cat./PL to be achieved and is the corresponding implementation observed?	<input type="checkbox"/>		
5	If error prevention (e.g., cross circuit to external signals) has been defined: Have the conditions for error prevention been implemented?	<input type="checkbox"/>		
6	Is the transmission speed set correctly according to the specifications?	<input type="checkbox"/>		
7	Is the operating mode set correctly according to the specifications?	<input type="checkbox"/>		
8	Is the address set correctly according to the specifications?	<input type="checkbox"/>		
No.	Requirement (optional)	Yes	No	Remark
9		<input type="checkbox"/>	<input type="checkbox"/>	
		Date	Signature (test engineer 1)	
		Date	Signature (test engineer 2)	

## B 2.3 Startup

Checklist for startup of the safety module				
<b>Device type/equipment identification</b>				
<b>Version: HW/FW/FW</b>		<b>Date</b>		
<b>Test engineer 1</b>		<b>Test engineer 2</b>		
<b>Remark</b>				
No.	Requirement (mandatory)	Yes	Remark	
1	Was startup completed according to the specifications (specifications from the planning phase or according to the user manual)?	<input type="checkbox"/>		
2	During startup, is it ensured that any person starting hazardous movements intentionally can only do so with a direct view of the danger zone?	<input type="checkbox"/>		
3	Are safety distances that must be observed calculated according to the response and delay times implemented?	<input type="checkbox"/>		
No.	Requirement (optional)	Yes	No	Remark
4		<input type="checkbox"/>	<input type="checkbox"/>	
		Date	Signature (test engineer 1)	
		Date	Signature (test engineer 2)	

## IB IL 24 LPSDO 8-PAC

## B 2.4 Validation

Checklist for validating the safety module			
Device type/equipment identification			
Version: HW/FW/FW		Date	
Test engineer 1		Test engineer 2	
Remark			
No.	Requirement (mandatory)	Yes	Remark
1	Have all the mandatory requirements for the "Planning" checklist been met?	<input type="checkbox"/>	
2	Have all the mandatory requirements for the "Assembly and electrical installation" checklist been met?	<input type="checkbox"/>	
3	Have all the mandatory requirements for the "Startup" checklist been met?	<input type="checkbox"/>	
4	Does the parameterization of the safe outputs correspond to the version and the actual connection of the controlled device?	<input type="checkbox"/>	
5	Has the assignment of the actuators to the safety logic outputs been checked?	<input type="checkbox"/>	
6	Has a function test been performed to check all safety functions, in which the module is involved?	<input type="checkbox"/>	
7	Have measures been taken to achieve a specific Cat.?	<input type="checkbox"/>	
8	Do all cables correspond to the specifications?	<input type="checkbox"/>	
9	Does the voltage supply correspond to the specifications for the protective extra-low voltage in accordance with PELV?	<input type="checkbox"/>	
10	Has the power supply of $U_M$ and $U_S$ in the Inline system from a power supply unit been implemented?	<input type="checkbox"/>	
11	Is external fuse protection of the module implemented (according to the specifications in this user manual for supply voltage $U_M$ )?	<input type="checkbox"/>	
12	Have measures been taken to prevent simple manipulation?	<input type="checkbox"/>	
13	Have measures been taken to prevent connectors being mixed up?	<input type="checkbox"/>	
14	Are the requirements for the actuators and cable installation observed according to the SIL/SIL CL/Cat./PL to be achieved?	<input type="checkbox"/>	
15	Are the specifications for the parameterization for each channel implemented?	<input type="checkbox"/>	
16	Are test intervals specified for testing the shutdown capability of the actuators, if this is required to achieve a SIL/SIL CL/Cat./PL?	<input type="checkbox"/>	
17	Has it been ensured that any person intentionally starting hazardous movements has a direct view of the danger zone?	<input type="checkbox"/>	
		Date	Signature (test engineer 1)
		Date	Signature (test engineer 2)

## C Appendix: Index

### A

Abbreviations .....	1-8
Acknowledgment .....	A-29
Actuators	
Connection options .....	2-6
Requirements .....	2-5
App-Ack-LPSDO .....	A-17
App-Diag-LPSDO .....	A-16
App-Diag-x .....	A-16
Assembly .....	4-4

### C

Configuration errors .....	A-30
Conformance with EMC Directive .....	10-6
Correct usage .....	1-6
Current carrying capacity .....	3-1, 3-2

### D

Data-LPSDO .....	A-14
Data-x .....	A-14
Decommissioning .....	9-1
Dev-Ack-LPSDO .....	A-16
Dev-Ack-x .....	A-16
Dev-Diag-x .....	A-16
Device errors .....	A-29
Outputs .....	2-10
Serious errors .....	2-10
Diagnostic indicators .....	2-7
Directives .....	1-6
Disposal .....	9-1

### E

Error classes .....	A-29
Error code .....	8-2
Error location .....	8-2
Error messages .....	A-29

### Errors

Acknowledgment .....	8-9
Behavior in the event of an error .....	A-29
Configuration .....	A-30
Device .....	A-29
General .....	8-6
Outputs .....	8-3
Parameterization .....	8-5, A-30
Removal .....	8-1
Supply voltage .....	8-4
System .....	A-29

### F

Feedback-Data-LPSDO .....	A-17
Free running circuit .....	6-2

### H

Housing dimensions .....	2-3
--------------------------	-----

### I

ID code .....	2-11
Indicators, diagnostic and status .....	2-7
Input address area .....	2-11
Installation	
Instructions .....	4-1
Insulation rating .....	1-3
INTERBUS	
Process data words .....	2-11
INTERBUS Safety	
Hotline .....	1-8
Island nodes .....	A-3

### L

Latest documentation .....	1-7
Length code .....	2-11
Location ID .....	5-1

### M

Machine stopping time .....	A-25
Maintenance .....	9-1
Mounting	
Location .....	4-1

**IB IL 24 LPSDO 8-PAC****O**

Output address area .....	2-11
Outputs .....	2-4
Device errors .....	2-10
Errors .....	8-3
I/O errors .....	2-9
Parameterization .....	5-2
Positive switching .....	2-4
Requirements for actuators .....	2-5
Single-channel assignment .....	2-4
Two-channel assignment .....	2-4

**P**

Package slip .....	4-1
Parameter channel .....	2-11
Parameterization .....	5-1
Outputs .....	5-2
Parameterization errors .....	A-30
PELV .....	1-3, 3-1, 3-2
Peripheral faults .....	A-30
Power supply unit .....	1-3
Processing time of the input .....	A-25
PROFIsafe address .....	5-1
Protective circuit .....	6-2
Prot-x .....	A-17

**Q**

Qualified personnel .....	1-1
---------------------------	-----

**R**

Register length .....	2-11
Registers	
App-Ack-LPSDO .....	A-17
App-Diag-LPSDO .....	A-16
App-Diag-x .....	A-16
Data-LPSDO .....	A-14
Data-x .....	A-14
Dev-Ack-LPSDO .....	A-16
Dev-Ack-x .....	A-16
Dev-Diag-x .....	A-16
Feedback-Data-LPSDO .....	A-17
Prot-x .....	A-17
Remote device .....	A-3
Removal .....	4-4
Repair .....	9-1

Replacement, module .....	7-3
Response time	
Typical .....	A-24
Response time of the actuator .....	A-25
Response time of the sensor .....	A-25
Restart .....	7-3, A-31

**S**

Safe state .....	2-9
Operating state .....	2-9
Outputs .....	2-9, 2-10
Safety notes .....	1-1
SafetyBridge island .....	A-3
Satellite .....	A-3
Security seal .....	1-2
Service information .....	A-29
Shutdown time .....	A-25
Guaranteed .....	A-25
Required .....	A-25
smartSafe system .....	A-2
Standards .....	1-6
Startup .....	7-1, A-31
Status indicators .....	2-7
Supply voltage	
UM .....	3-1, 3-2
System errors .....	A-29

**T**

Test pulses .....	2-5
Transmission speed .....	1-2
Set .....	4-2

**V**

Validation .....	7-3
------------------	-----

## D Appendix: Revision history

Revision	Date	Contents	
01	12/2009	First publication	
02	2011-04-18	Covering sheet	Cover image replaced
		Inside of covering sheet	HW revision 01 supplemented
		Section 1.4	New: "Safety for starting applications"
		Section 1.5	Table deleted, note on certificates in Internet supplemented
		Page 6-6 Page 6-9	Text For <b>PROFIsafe</b> , an "operator acknowledgment" leads to a positive edge and can thus result in the outputs being re-enabled. Changed to: An "operator acknowledgment" leads to a positive edge and can thus result in the outputs being re-enabled.
		Page 10-5	Maximum switching frequency: 1 Hz at 1 A and 1 H; 0.2 Hz at > 1 A changed to 1 Hz; 0.2 Hz at > 1 A A
Appendix A	Appendix B "Memory sizes for the safety logic" moved to appendix A		
03	2013-06-25	Page 4-3 Page A-5	Switch position for SafetyBridge V3 added
04	2019-08-09	Outside + inside of covering sheet	Order No. deleted Revision HW/FW/FW edited



# SCATTERGOOD & JOHNSON LTD

ELECTRICAL ENGINEERING & FLUID CONTROL DISTRIBUTORS

Est.1899

At Scattergood & Johnson Ltd, we pride ourselves on being a technical distributor to specialist industries.

Working with a range of quality product suppliers across a number of specialist markets, we are not your average 'box shifter' - we are your technical and supply chain partner.

We fully support every product we sell - for free! Our internal team and external sales engineers can answer any product or application question, no matter the complexity.

Backing up this technical ability is a range of 50,000+ products available from stock for nationwide next day delivery (same day if required!), or you can collect what you need from any of our trade counters around the UK.

Select your specialist interest below to learn more about how we can help.

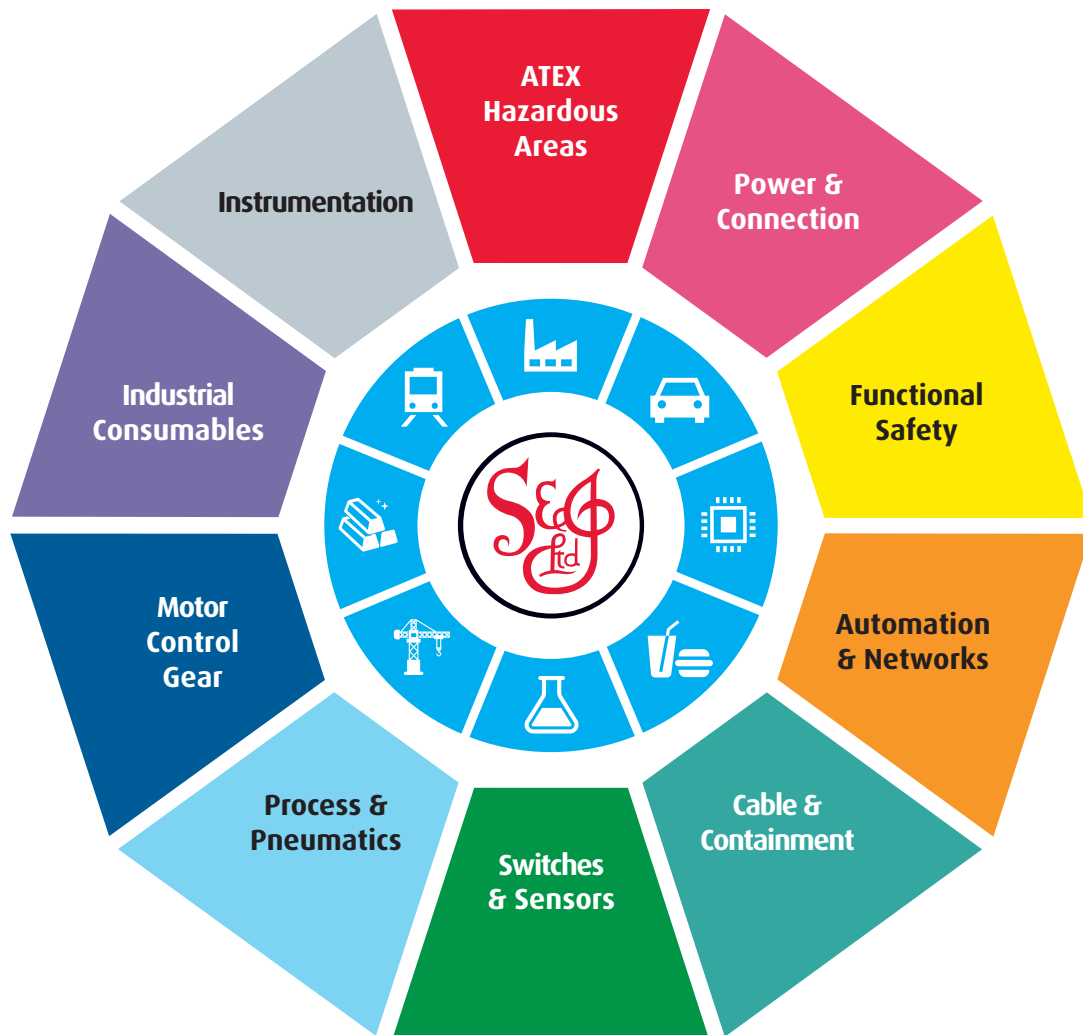

Online, In Branch and On the Road - Scattergood & Johnson Ltd, there when you need us.

# [www.scatts.co.uk](http://www.scatts.co.uk)