

MINI-PS- 12- 24DC/48DC/0.7

Power supply unit

INTERFACE

Data sheet
104349_en_00

© PHOENIX CONTACT 2010-04-26



1 Description

The DC/DC converter converts the DC voltage of 12 V DC ... 24 V DC to an adjustable, controlled and electrically isolated 48 V DC output voltage.

Due to electrical isolation, the DC voltage circuits are electrically isolated from each other in a safe way. With a design width of only 22.5 mm, the housing is extremely slim.

Features

- Reliable power supply unit even at high ambient temperatures
- Reliable starting of heavy loads using the U/I characteristic curve
- Can be used worldwide in all industrial sectors due to a wide-range input and an international approval package
- High operating safety due to long mains buffering under full load and high MTBF (> 500,000 h)



DANGER OF EXPLOSION!

Only remove equipment when it is disconnected and not in the potentially explosive area.



DANGER

Components with dangerously high voltage and high stored energy are located in the device!
Never carry out work on live parts!
Depending on the ambient temperature and the load, the housing can become very hot!



Make sure you always use the latest documentation.
It can be downloaded from the product at www.phoenixcontact.net/catalog.

2 Table of contents

1	Description	1
	Features.....	1
2	Table of contents.....	2
3	Ordering data	3
4	Technical data	3
5	Structure.....	5
6	Block diagram	6
7	Safety notes	6
8	Installation	7
9	Installation position.....	7
	Assembly	8
	Removing.....	8
10	Input	8
	Protection of the primary side.....	8
11	Output	9
	Protection of the secondary side	9
12	Signaling	9
	Active signal output.....	10
13	Function	10
	Thermal behavior	10
	Parallel operation	10
	Redundant operation	11
	Increased performance	11

2

3 Ordering data

Description	Type	Order No.	Pcs. / Pkt.
DC/DC converter, primary-switched, slim design, input: 12 - 24 V DC, output: 48 V DC/0.7 A	MINI-PS- 12- 24DC/48DC/0.7	2320021	1

4 Technical data

Input data	
Input nominal voltage range	12 V DC ... 24 V DC
DC input voltage range	10 V DC ... 32 V DC (> 10.5 V DC start)
DC frequency range	0 Hz
Current consumption	Approx. 3.2 A (12 V DC) Approx. 1.6 A (24 V DC)
Inrush current limitation	< 10 A (typical)
I^2t	0.3 A ² s
Power failure bypass	> 2 ms (12 V DC) > 12 ms (24 V DC)
Typical response time	< 0.5 s
Input fuse, integrated	6.3 A (slow-blow, internal)
Output data	
Nominal output voltage	48 V DC \pm 1%
Setting range of the output voltage	30 V DC ... 56 V DC (> 48 V constant capacity)
Output current	0.7 A (-25 °C ... 60 °C)
Derating	from 60°C to 70°C: 2.5% per Kelvin
Efficiency	> 87 % (at 24 V DC and nominal values)
Residual ripple	< 20 mV _{PP} (20 MHz)
Peak switching voltages	< 10 mV _{PP} (20 MHz)
Connection in parallel	Yes, for assembling redundant systems and increasing efficiency
Connection in series	Yes
Surge protection against internal surge voltages	yes, limited to approx. 60 V DC
Resistance to reverse feed	60 V DC
Power consumption	
Maximum power dissipation idling	1.5 W
Power loss nominal load max.	4.5 W
DC OK active	
Output description	$U_{OUT} > 0.9 \times U_N$: High signal
Status display	"DC OK" LED green / $U_{OUT} > 0.9 \times U_N$: LED ON
General data	
Insulation voltage input/output	1 kV (routine test) 1.5 kV (type test)
Degree of protection	IP20
Class of protection	III
MTBF	> 500 000 h in acc. with IEC 61709 (SN 29500)
Type of housing	Polyamide PA, color: green
Housing material	Polyamide (PA)
Dimensions W / H / D (state of delivery)	22.5 mm / 99 mm / 107 mm
Weight	0.2 kg

Ambient conditions

Ambient temperature (operation)	-25 °C ... 70 °C (> +60°C derating)
Ambient temperature (storage/transport)	-40 °C ... 85 °C
Max. permissible relative humidity (operation)	≤ 95 % (At +25°C, no condensation)
Vibration (operation)	< 15 Hz, amplitude ±2.5 mm in acc. with IEC 60068-2-6 15 Hz ... 150 Hz, 2.3 g
Shock	30g in all directions in acc. with IEC 60068-2-27
Pollution degree in acc. with EN 50178	2
Climatic class	3K3 (in acc. with EN 60721)

Approvals

UL approvals	UL/C-UL listed UL 508 UL/C-UL Recognized UL 60950
--------------	--



Current approvals can be found for the product in the download area.

Conformance with EMC guideline 2004/108/EC and for low-voltage guideline 2006/95/EC**Noise immunity according to EN 61000-6-2**

Electrostatic discharge	EN 61000-4-2
	Housing > Level 3
	Contact discharge 8 kV (Contact discharge)
	Discharge in air 8 kV (Air discharge)
	Comments Criterion B
Electromagnetic HF field	EN 61000-4-3
	Housing Level 3
	Frequency range 80 MHz ... 3 GHz
	Field intensity 10 V/m
	Comments Criterion A
Fast transients (burst)	EN 61000-4-4
	Input 4 kV (level 4 - asymmetrical: conductor to ground)
	Output 2 kV (level 3 - asymmetrical: conductor to ground)
	Signal 1 kV (Level 2 - asymmetrical cable to ground)
	Comments Criterion B
Surge current loads (surge)	EN 61000-4-5
	Input 2 kV (Level 3) 1 kV (Level 3)
Conducted interference	EN 61000-4-6
	Input/output Level 3
	Frequency range 0.15 MHz ... 80 MHz (10 V)
Voltage dips	EN 61000-4-11
	Input (> 10 ms)
	Comments Criterion B

Emitted interference in acc. with EN 61000-6-3

Radio interference voltage in acc. with EN 55011	EN 55011 (EN 55022) Class B, area of application: Industry and residential
Emitted radio interference in acc. with EN 55011	EN 55011 (EN 55022) Class B, area of application: Industry and residential

5 Structure

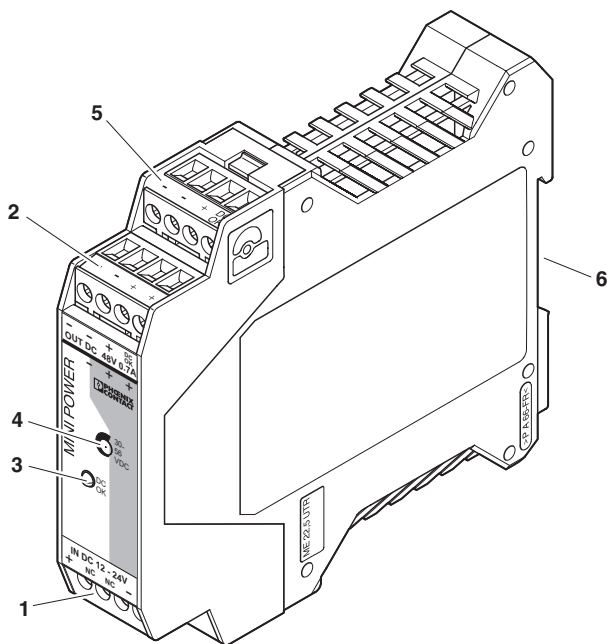

- 1 AC input
- 2 DC output
- 3 Green LED: DC OK
- 4 Potentiometer: 30 V DC ... 56 V DC
- 5 Active switching output: DC OK
- 6 Universal DIN rail adapter UTA 107/30

	[mm ²]		AWG	[Nm] Torque
	solid	stranded		
Input	0.2 - 2.5	0.2 - 2.5	24 - 14	0.5 - 0.6
Output	0.2 - 2.5	0.2 - 2.5	24 - 14	0.5 - 0.6
Signal	0.2 - 2.5	0.2 - 2.5	24 - 14	0.5 - 0.6

Input data

Input nominal voltage range	12 V DC ... 24 V DC
DC input voltage range	10 V DC ... 32 V DC (> 10.5 V DC start)
DC frequency range	0 Hz
Input fuse, integrated	6.3 A (slow-blow, internal)
Type of connection	Pluggable screw connection
Stripping length	7 mm

Output data

Nominal output voltage	48 V DC \pm 1%
Setting range of the output voltage	30 V DC ... 56 V DC (> 48 V constant capacity)
Output current	0.7 A (-25 °C ... 60 °C)
Type of connection	Pluggable screw connection
Stripping length	7 mm

6 Block diagram

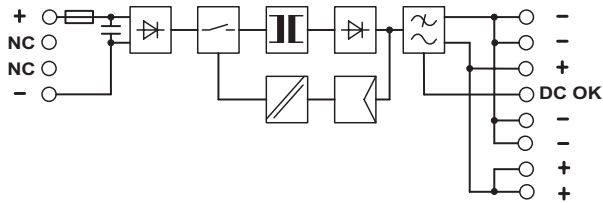

7 Safety notes



DANGER OF EXPLOSION!

Only remove equipment when it is disconnected and not in the potentially explosive area.

DANGER

Components with dangerously high voltage and high stored energy are located in the device!

Never carry out work on live parts!

Depending on the ambient temperature and the load, the housing can become very hot!



CAUTION

Before startup please ensure:

The mains connection has been carried out by a competent person and protection against electric shock is guaranteed!

The device can be disconnected outside the power supply unit in accordance with the regulations as in EN 60950 (e.g. through primary side line protection)!

All feed lines are sufficiently protected and dimensioned!

All output lines are dimensioned according to the maximum output current of the device or separately protected!

Sufficient convection must be guaranteed.



ATTENTION: Danger if used improperly

The power supply units are built-in devices. The device may only be installed and put into operation by qualified personnel. The corresponding national regulations must be observed.

8 Installation

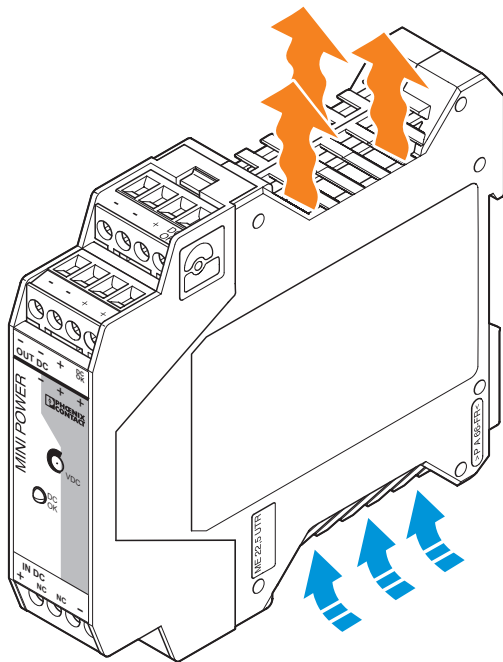

ATTENTION: Module can become damaged

To ensure sufficient convection, we recommend the following minimum spacing be used between modules: 5 cm above and below



The power supply unit can be snapped onto all DIN rails in acc. with EN 60715.

9 Installation position

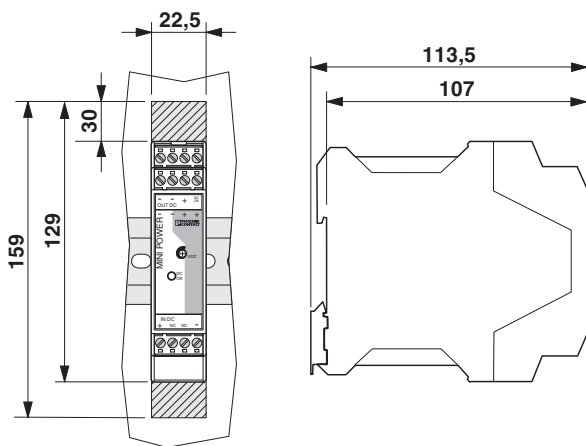

Mounting position: Installation depth 107 mm (+ DIN rail)

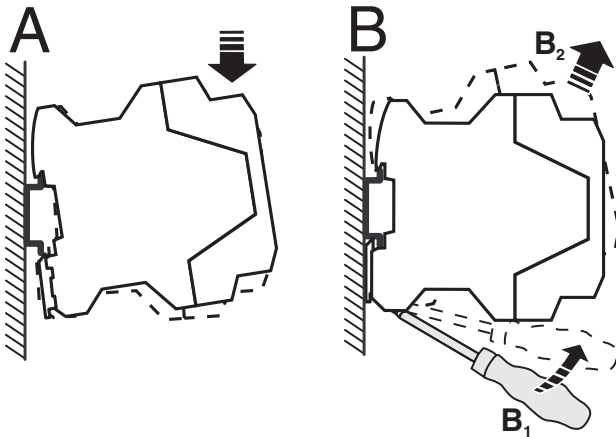
**Assembly**

Position the module with the DIN rail guide on the upper edge of the DIN rail, and snap it in with a downward motion.

Removing

Pull the snap lever open with the aid of a screwdriver and slide the module out at the lower edge of the DIN rail.

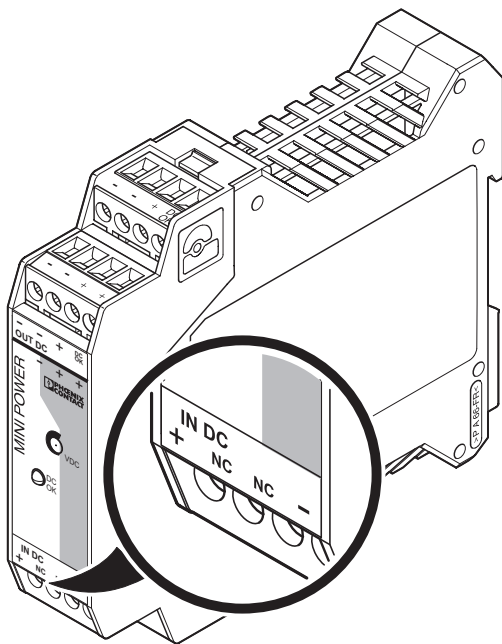
10 Input**ATTENTION: Module can become damaged**

If an internal fuse is triggered, there is a device malfunction. In this case, the device must be inspected in the factory.

The 12 V DC ... 24 V DC connection is established using the "+" and "-" screw connections.

Protection of the primary side

The device must be installed in acc. with the regulations as in EN 60950. An internal fuse is provided for device protection. Additional device protection is not required.

11 Output

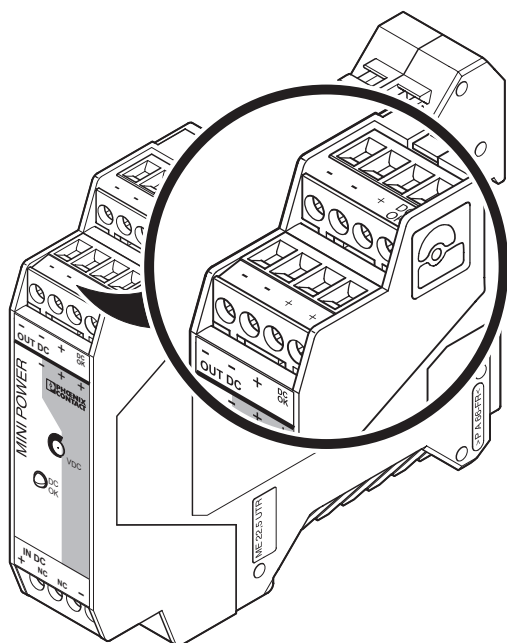

ATTENTION: Module can become damaged

Make sure that all output lines are dimensioned according to the maximum output current or are separately protected. The cables on the secondary side must have sufficiently large cross sections in order to keep the voltage drops on the lines as low as possible.

The connection is established via screw connection terminal blocks "+" and "-" of the DC output. The output voltage can be adjusted on the potentiometer from 30 V DC ... 56 V DC.

Protection of the secondary side

The device is electronically protected against short circuit and idling. In the event of a malfunction, the output voltage is limited to 60 V DC. Make sure that all output lines are dimensioned according to the maximum output current or are separately protected! The cables on the secondary side should have large cross sections in order to keep the voltage drops on the lines to a minimum.

12 Signaling

For function monitoring, there is the active DC OK switching output and the DC OK LED.

	State 1	State 2
"DC OK" LED	ON	OFF
Active DC OK switching output	U_{OUT} (with reference to "-")	$U = 0$ V (in reference to "-")
Meaning	Normal operation of the power supply unit. $U_{OUT} > 0.9 \times U_N$	$U_{OUT} \leq 0.9 \times U_N$ Secondary load short-circuit or overload No mains voltage or device defective

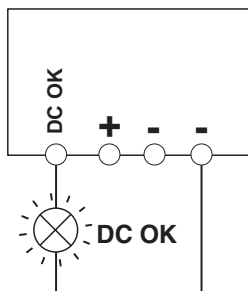

Active signal output

The DC output signal in normal operation of the power supply unit ($U_{OUT} > 0.9 \times U_N$) is between the "DC OK" and "-" connection terminal blocks and can carry a maximum of 20mA. By switching from "active high" to "low", the DC OK signal output signalizes when the output voltage is fallen short of by more than 10%.

The DC OK signal is decoupled from the power output. It is thus not possible for devices connected in parallel to act as an external power supply.

13 Function

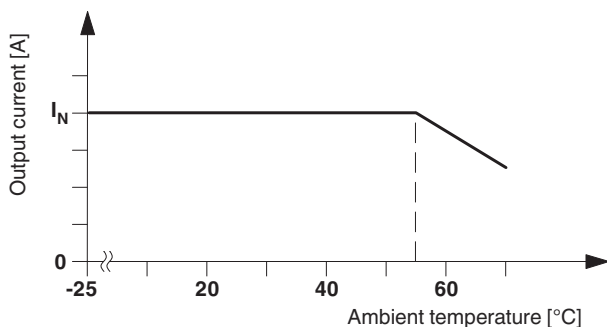

Thermal behavior

The device can supply a nominal output current of 0.7 A with ambient temperatures of up to 60°C. For ambient temperatures above 60°C, the output current must be reduced by 2.5% per Kelvin increase in temperature. From 70°C onwards or in the case of thermal overload, the device reduces the output capacity for its own protection, and returns to normal operation when it has cooled down.

Parallel operation

Devices of the same type can be connected in parallel to increase both redundancy and power. By default upon delivery, no further adjustments are required.

If the output voltage is adjusted, a uniform distribution of power is guaranteed by setting all parallel operated power supply units to exactly the same output voltage.

To ensure symmetrical current distribution we recommend that all cable connections from the power supply unit to the busbar are the same length and have the same cross section. Depending on the system, for parallel connection of more than two power supplies a protective circuit should be installed at each individual device output (e.g., decoupling diode, DC fuse or circuit breaker). This prevents high return currents in the event of a secondary device fault.

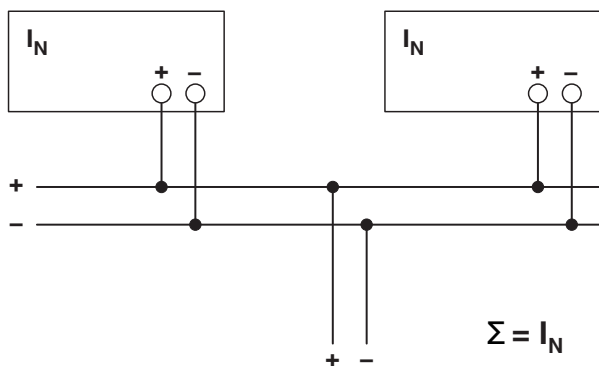

Redundant operation

Redundant circuits are suitable for supplying systems, which place particularly high demands on operational safety. If a fault occurs in the primary circuit of the first power supply unit, the second device automatically takes over the complete power supply without interruption, and vice versa. For this purpose, the power supply units to be connected in parallel must be large enough that the total current requirements of all loads can be fully met by one power supply unit. External decoupling diodes are required for 100% redundancy (ST 4-QUATTRO-DIO 1N 5408/L-R, Order No. 3037782, ST 4-QUATTRO-DIO 1N 5408/R-L, Order No. 3037795).

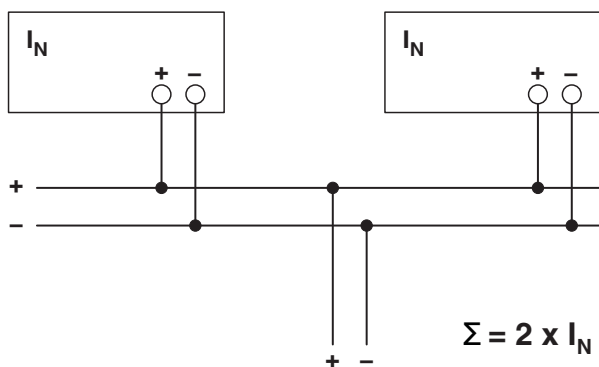

Increased performance

For n parallel connected devices, the output current can be increased to $n \times I_N$. Parallel connection for increasing power is used when extending existing systems. A parallel connection is recommended if the power supply unit does not cover the current consumption of the most powerful load. Otherwise, the load should be divided between individual devices that are independent from one another.



SCATTERGOOD & JOHNSON LTD

ELECTRICAL ENGINEERING & FLUID CONTROL DISTRIBUTORS

Est.1899

At Scattergood & Johnson Ltd, we pride ourselves on being a technical distributor to specialist industries.

Working with a range of quality product suppliers across a number of specialist markets, we are not your average 'box shifter' - we are your technical and supply chain partner.

We fully support every product we sell - for free! Our internal team and external sales engineers can answer any product or application question, no matter the complexity.

Backing up this technical ability is a range of 50,000+ products available from stock for nationwide next day delivery (same day if required!), or you can collect what you need from any of our trade counters around the UK.

Select your specialist interest below to learn more about how we can help.

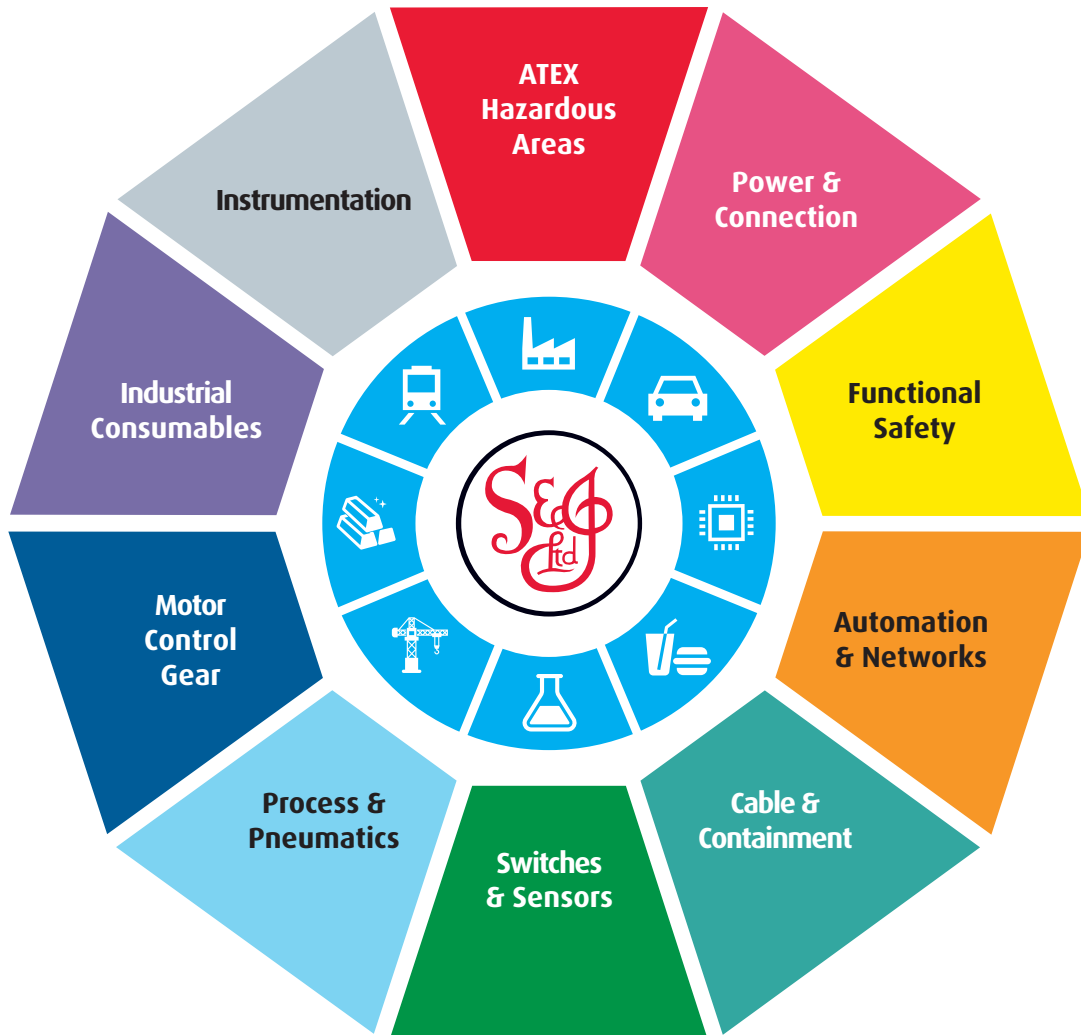

Online, In Branch and On the Road - Scattergood & Johnson Ltd, there when you need us.

www.scatts.co.uk