

# QUINT-UPS/ 24DC/ 24DC/40

## Uninterruptible power supply

### INTERFACE

Data sheet  
104660\_en\_03

© PHOENIX CONTACT 2019-05-22



## 1 Description

Uninterruptible power supplies (UPS) continue to deliver power even if the mains breaks down.

An uninterruptible solution consists of three function units:

- Power supply
- Electronic switchover unit
- Power storage device

The product described here is an electronic switchover unit. In the event of mains breakdowns or failures, it switches to battery operation without interruption so that loads continue to be consistently supplied.

As an option, you can monitor and configure the device with the free UPS-CONF software. The IFS-CONFSTICK memory stick is available for convenient transfer of parameters between more than one QUINT-UPS.

### Features

- IQ technology for maximum system availability. The intelligent battery management optimizes and keeps you informed on the remaining runtime, current state of charge, service life and performance of the power storage device.
- Generous power reserve POWER BOOST
- Optimum use of the buffer time
- Preventive battery monitoring
- Fast battery charging
- Extensive signaling and parameterization
- SFB technology



Make sure you always use the latest documentation.  
It can be downloaded from the product at [www.phoenixcontact.net/catalog](http://www.phoenixcontact.net/catalog).



This data sheet is valid for all products listed on the following page:

## 2 Table of contents

1	Description.....	1
2	Table of contents .....	2
3	Ordering data.....	3
4	Technical data .....	4
5	Safety regulations and installation notes.....	8
6	Structure .....	9
7	Basic circuit diagram.....	11
8	Installation.....	12
	8.1 Convection .....	12
	8.2 Mounting position .....	12
	8.3 Mounting on a DIN rail .....	13
	8.4 Connection terminal blocks .....	14
	8.5 Installation of individual components .....	15
9	Connection and protection .....	16
	9.1 Input and protection of the primary side .....	16
	9.2 Output and protection on the secondary side .....	16
	9.3 Power storage device .....	17
	9.4 SFB technology.....	17
	9.5 Power reserves.....	17
	9.6 Temperature response .....	17
10	Signaling .....	18
	10.1 LED and bar graph test.....	19
	10.2 LED indicator .....	19
	10.3 Bar graph-display when the communication cable is installed .....	20
	10.4 Bar graph display without communication cable .....	20
11	Function .....	21
	11.1 IQ technology.....	21
	11.2 SOC application example .....	21
	11.3 SOH/SOF application example .....	21
	11.4 Charging characteristic.....	22
	11.5 Fast battery charging, intelligent charging (contact I< IN) .....	22
	11.6 Setting the buffer time.....	23
	11.7 PC mode .....	23
	11.8 Remote control (contact R1, R2) .....	25
12	Interfaces.....	25
	12.1 IFS-USB-DATACABLE .....	25
	12.2 IFS-CONFSTICK.....	25
13	Servicing.....	26
14	Application examples.....	27
	14.1 Parallel connection of the power storage devices .....	27
	14.2 Parallel connection for redundancy.....	28

### 3 Ordering data

Description	Type	Order No.	Pcs. / Pkt.
Uninterruptible power supply with IQ technology 24 V/40 A. Provides information regarding the charging state, remaining runtime, and service life of your rechargeable battery module at all times and thereby increases system availability.	QUINT-UPS/ 24DC/ 24DC/40	2320241	1
Accessories	Type	Order No.	Pcs. / Pkt.
Rechargeable battery module, lead AGM, VRLA technology, 24 V DC, 7.2 Ah, tool-free battery replacement, automatic detection and communication with QUINT UPS-IQ	UPS-BAT/VRLA/ 24DC/ 7.2AH	2320319	1
Rechargeable battery module, lead AGM, VRLA technology, 24 V DC, 12 Ah, tool-free battery replacement, automatic detection and communication with QUINT UPS-IQ	UPS-BAT/VRLA/ 24DC/12AH	2320322	1
Rechargeable battery module, LI-ION technology, 24 V DC, 60 Wh, for ambient temperatures of -20°C ... +60°C, automatic detection and communication with QUINT UPS-IQ	UPS-BAT/LI-ION/24DC/60WH	2320351	1
Rechargeable battery module, lead AGM, VRLA technology, 24 V DC, 38 Ah, automatic detection and communication with the QUINT UPS-IQ	UPS-BAT/VRLA/ 24DC/38AH	2320335	1
Configuration software for QUINT UPS can be downloaded free of charge.	UPS-CONF	2320403	1
Used for communication between the UPS CONF configuration software and the QUINT UPS IQ and TRIO UPS uninterruptible power supply units.	IFS-USB-DATACABLE	2320500	1
Multi-functional memory block for the INTERFACE system for easy storage and backup of the configuration.	IFS-CONFSTICK	2986122	1

## 4 Technical data

Input data	
Nominal input voltage	24 V DC
DC input voltage range	18 V DC ... 30 V DC
Buffer period	0.5 h ()
Current consumption mains mode	
Max.	51.9 A
No load	66 mA
Charging process	6.9 A
Fixed connect threshold	≤ 22 V DC
Output data	
Nominal output voltage	24 V DC
Output voltage range	18 V DC ... 30 V DC
Nominal output current	40 A
Derating	60 °C ... 70 °C (2.5%/K)
Output current limit	(In mains mode according to connected upstream current limiting device) > 45 A (Battery operation)
Power dissipation (mains mode)	
Idle	1.6 W
Nominal Load	9.3 W
BOOST	10.3 W
Power dissipation (battery operation)	
Idle	1.4 W
Nominal Load	20.9 W
BOOST	26.5 W
Output power	960 W
Efficiency	> 98.7 %
Connection in parallel	Yes, up to 2 modules with redundancy module
Connection in series	No
Output data (mains operation)	
Nominal output voltage	24 V DC
Output voltage range	18 V DC ... 30 V DC
Output current (according to connected upstream power supply unit)	
Nominal output current $I_N$	40 A (-25 °C ... +60 °C)
POWER BOOST $I_{BOOST}$	45 A (-25 °C ... +40 °C)
SFB technology $I_{SFB}$	215 A (-25 °C ... +60 °C)
Duration	12 ms (SFB technology)
Output data (battery operation)	
Nominal output voltage	24 V DC
Output voltage range	19.2 V DC ... 27.6 V DC ( $U_{OUT} = U_{BAT} - 0.5 \text{ V DC}$ )
Output current	
Nominal output current $I_N$	40 A (-25 °C ... +60 °C)
POWER BOOST $I_{BOOST}$	45 A (-25 °C ... +40 °C)
SFB technology $I_{SFB}$	215 A (-25 °C ... +60 °C)
Duration	15 ms (SFB technology)

**Power storage device**

Nominal voltage $U_N$	24 V DC
End-of-charge voltage	24 V DC ... 29 V DC (temperature compensated)
Temperature compensation	42 mV/K (preset)
Nominal capacity range	7 Ah ... 200 Ah
Charge current	0.2 A ... 5 A
Battery presence check (time interval)	1 min

**Power In OK**

Status display	LED / Static to / green
----------------	-------------------------

**Alarm**

Inverting with the UPS-CONF configuration and management software

Switching output	Relay
Maximum switching voltage	$\leq 30$ V AC/DC
Maximum switching current	$\leq 100$ mA
Status display	LED / Static to / red

**Battery charge**

Signal options are adjustable with the UPS-CONF configuration and management software

Switching output	Relay
Maximum switching voltage	$\leq 30$ V AC/DC
Maximum switching current	$\leq 100$ mA
Status display	LED bar graph / dynamic / green

**Battery mode**

Signal options are adjustable with the UPS-CONF configuration and management software

Switching output	Relay
Maximum switching voltage	$\leq 30$ V AC/DC
Maximum switching current	$\leq 100$ mA
Status display	LED / Static to / yellow

**General data**

MTBF	> 500000 h
Mounting position	horizontal DIN rail NS 35, EN 60715
Housing material	Steel sheet, zinc-plated
Dimensions W / H / D	47 mm / 130 mm / 125 mm
Dimensions W / H / D (90° turned)	122 mm / 130 mm / 50 mm
Weight	0.7 kg

**Security**

Degree of protection	IP20
Protection class	III

**Connection data**

Connection method	Screw connection
Conductor cross section, solid	0.5 mm <sup>2</sup> ... 16 mm <sup>2</sup>
Conductor cross section, stranded	0.5 mm <sup>2</sup> ... 16 mm <sup>2</sup>
Conductor cross section AWG/kcmil	8 ... 6
Stripping length	10 mm
Screw thread	M4
Tightening torque	1.2 Nm ... 1.5 Nm

**Ambient conditions**

Ambient temperature (operation)	-25 °C ... 70 °C
Ambient temperature (storage/transport)	-40 °C ... 85 °C
Max. permissible relative humidity (operation)	≤ 95 % (25°C, no condensation)
Vibration (operation)	< 15 Hz, amplitude ±2.5 mm in acc. with IEC 60068-2-6 15 Hz ... 150 Hz, 2.3 g t <sub>v</sub> = 90 min.
Shock	30g in all directions in acc. with IEC 60068-2-27
Climatic class	3K3 (in acc. with EN 60721)

**Standards**

Electrical safety (of information technology equipment)	EN 60950-1/VDE 0805 (SELV) EN 61558-2-17
Electronic equipment for use in electrical power installations	EN 50178/VDE 0160 (PELV)

**Approvals**

UL approvals	UL/C-UL Recognized UL 60950 UL Listed UL 508
--------------	---

**Conformance with EMC Directive 2004/108/EC****Noise immunity according to EN 61000-6-2**

	<b>EN 61000-6-2 requirement</b>	<b>Tested</b>
<b>Electrostatic discharge EN 61000-4-2</b>		
Housing contact discharge	4 kV (Test intensity 2)	8 kV (Test intensity 4)
Housing air discharge	8 kV (Test intensity 3)	15 kV (Test intensity 4)
Comments	Criterion B	Criterion A
<b>Electromagnetic HF field EN 61000-4-3</b>		
Frequency range	80 MHz ... 1 GHz	80 MHz ... 1 GHz
Test field strength	10 V/m	20 V/m
Frequency range	1.4 GHz ... 2 GHz	1 GHz ... 3 GHz
Test field strength	3 V/m (Criterion A)	10 V/m (Test intensity X / 3)
<b>Fast transients (burst) EN 61000-4-4</b>		
Input	2 kV (Test intensity 3 - asymmetrical)	2 kV (Test intensity 3 - asymmetrical)
Output	2 kV (Test intensity 3 - asymmetrical)	2 kV (Test intensity 3 - asymmetrical)
Signal	1 kV (Test intensity 3 - asymmetrical)	2 kV (Test intensity 4 - asymmetrical)
Comments	Criterion B	Criterion A
<b>Surge current loads (surge) EN 61000-4-5</b>		
Input/Output	+/- 0.5 kV (Asymmetrical) 0.5 kV (symmetrical)	1 kV (symmetrical) 2 kV (Asymmetrical)
Signal	+/- 1 kV (Asymmetrical)	1 kV (Asymmetrical)
Comments	Criterion B	Criterion A
<b>Conducted interference EN 61000-4-6</b>		
Input/Output/Signal	asymmetrical	asymmetrical
Frequency range	0.15 MHz ... 80 MHz	0.15 MHz ... 80 MHz
Voltage	10 V (Test intensity 3)	10 V (Test intensity 3)
Comments	Criterion A	Criterion A

**Emitted interference in acc. with EN 61000-6-3**

Radio interference voltage in acc. with EN 55011	EN 55011 (EN 55022) Class B, area of application: Industry and residential
Emitted radio interference in acc. with EN 55011	EN 55011 (EN 55022) Class B, area of application: Industry and residential

## 5 Safety regulations and installation notes



### EXPLOSION HAZARD

Only remove equipment when it is disconnected and not in the potentially explosive area!

### DANGER

Never carry out work on live parts!  
The housing can become very hot, depending on the ambient temperature and load!



### CAUTION: Risk of injury

Use the device with the UPS-BAT.... recommended in the table of accessories. When using power storage devices other than UPS-BAT..., make sure that the corresponding parameters for the charging characteristics are adjusted and adhered to.

Phoenix Contact accepts no liability or responsibility for possible for any consequential damage.



### CAUTION:

Before startup please ensure:

The connection must be carried out by a competent person and protection against electric shock guaranteed.

It must be possible to switch off power to device according to EN 60950.

All feed lines are sufficiently protected and dimensioned!

All output lines are dimensioned according to the maximum output current of the device or separately protected!

Sufficient convection must be guaranteed.

Observe mechanical and thermal limits.



### ATTENTION: Danger if used improperly

Uninterruptible power supplies are installable devices. Installation and startup may only be carried out by qualified personnel. The relevant country-specific regulations must be observed.



### CAUTION: Risk of injury

Cover termination area after installation in order to avoid accidental contact with live parts (e. g., installation in control cabinet).



Do not dispose of used batteries in the household waste! Dispose of these according to the currently valid national regulations.



They can also be returned to Phoenix Contact or the manufacturer.

## 6 Structure

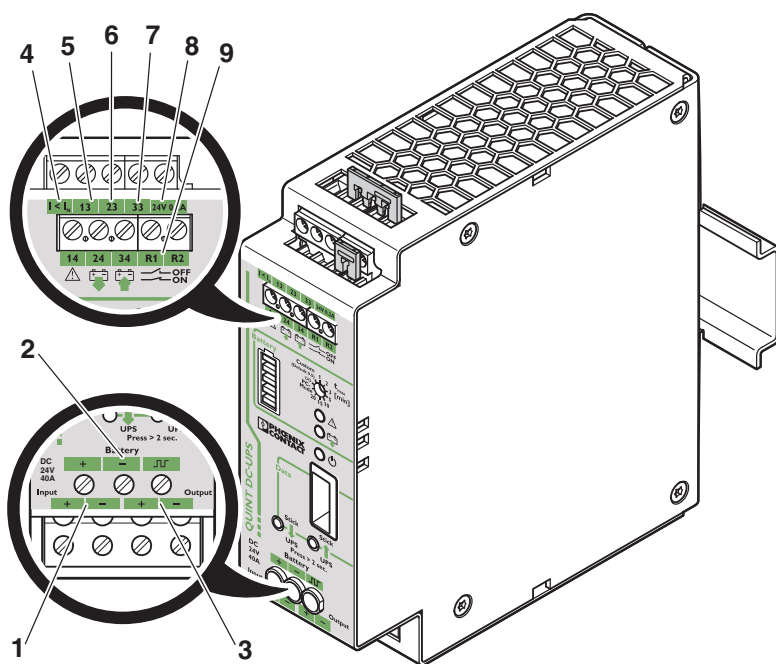

Figure 1 Connection terminal blocks

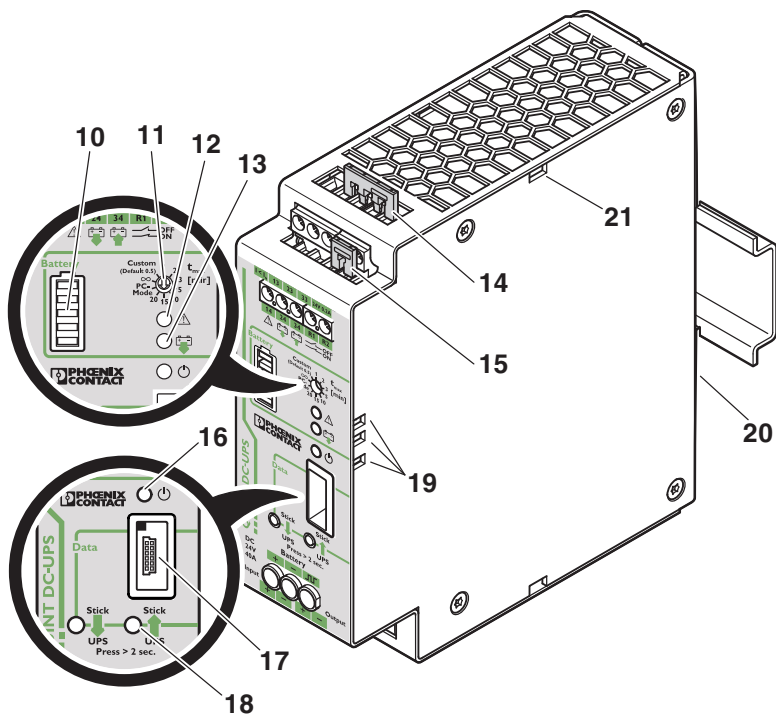

Figure 2 Function elements

**Connections / Operating elements**

- 1 DC input, 18 V DC ... 30 V DC
- 2 Power storage device connection, 24 V DC (+, -, communication between UPS and power storage device)
- 3 DC output, 24 V DC, buffered
- 17 Data port for data linking to the PC or the use of a memory block
- 18 Button for use of the memory block

**Mains mode, charging**

- 16 Green LED: Power In OK, mains mode
- 10 Bar graph for displaying the current charging state of the power storage device
- 7 Floating relay contact 33/34: battery charge
- 4  $I < I_N$ , fast battery charging

**Battery operation, discharging**

- 13 Yellow LED: battery mode
- 6 Floating relay contact 23/24: battery mode
- 11 Buffer time setting: unlimited  $\leq$ , 1 ... 20 mins., customized (customized default: 0.5), PC mode
- 9 Remote control (R1, R2)
- 15 Remote control plug-in bridge, pre-installed

**General**

- 12 Red LED: alarm
- 5 Floating contact 13/14: alarm
- 8 24 V DC supply voltage, maximum current limit 0.2 A for the signal contacts 13, 23, 33
- 14 Plug-in bridge for signal contact supply voltages, pre-installed
- 19 LED windows for flat mounting position
- 21 Accommodation for cable binders
- 20 Universal snap-on foot for EN DIN rails

## 7 Basic circuit diagram

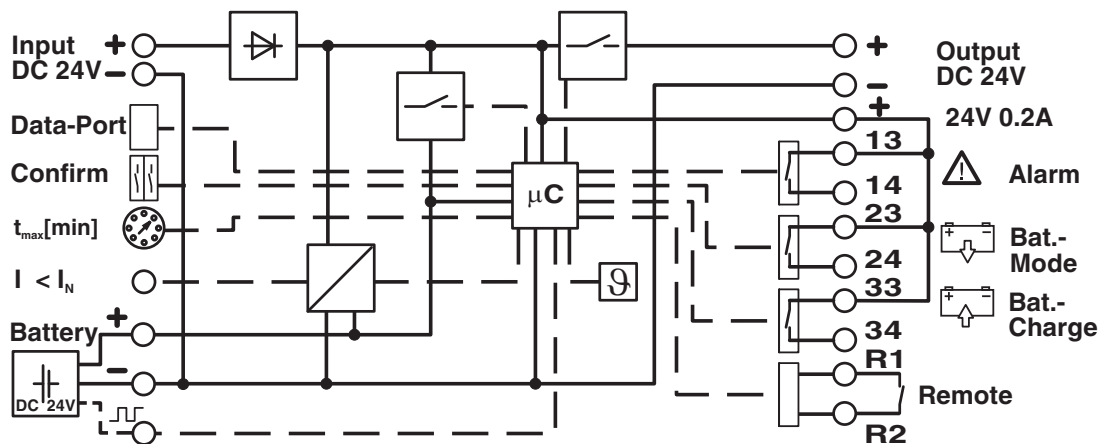

Element	Meaning
	Microprocessor
	Decoupling
	Charging unit
	Switch
	Temperature sensor
	Selector switch

## 8 Installation

### 8.1 Convection

The device supplies the specified values in the case of sufficient convection cooling and when mounted on a horizontal DIN rail.

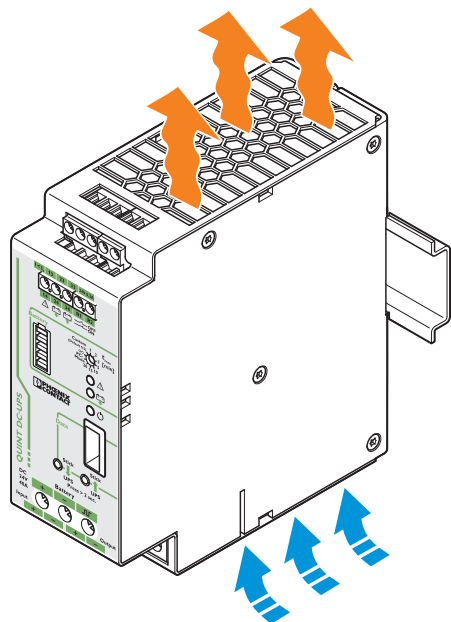

To enable sufficient convection, we recommend a minimum vertical gap to other modules of 5 cm.  
A lateral gap of 5 mm is recommendable.



The module can be snapped onto all DIN rails according to EN 60715 and must be mounted horizontally (connecting terminal blocks on top and bottom).

Figure 3 Convection

### 8.2 Mounting position

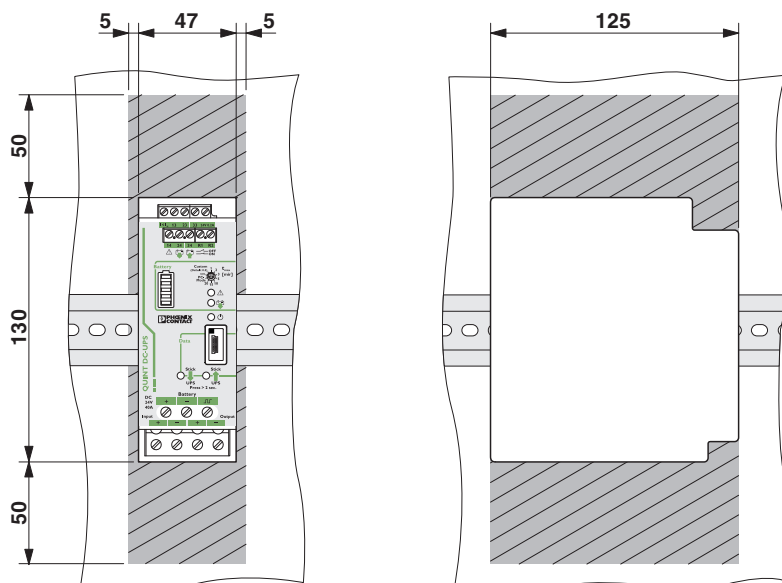
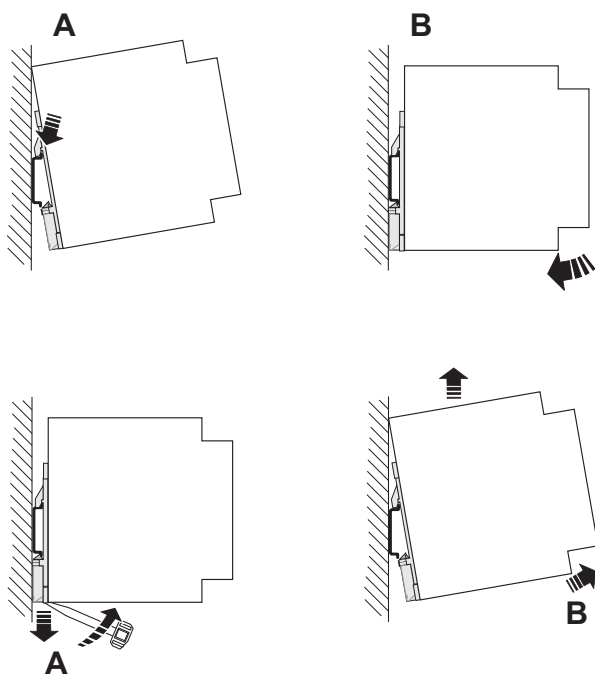

Figure 4 Installation dimensions

Installation depth 125 mm

### 8.3 Mounting on a DIN rail



#### Slim-style installation

##### Assembly:

Position the module with the DIN rail guide on the upper edge of the DIN rail, and snap it in with a downward motion.

##### Removing:

Pull the snap lever open with the aid of a screwdriver and slide the module out at the lower edge of the DIN rail.

Figure 5 Mounting and removing

#### Mounting position rotated 90°

Low-profile installation can be achieved by mounting the device at right-angles to the DIN rail. Mount the DIN rail adapter (UTA 107) as described in the figure. No additional mounting material is required. Fixing screws: Torx T10 (torque 0.8 Nm ... 0.9 Nm).

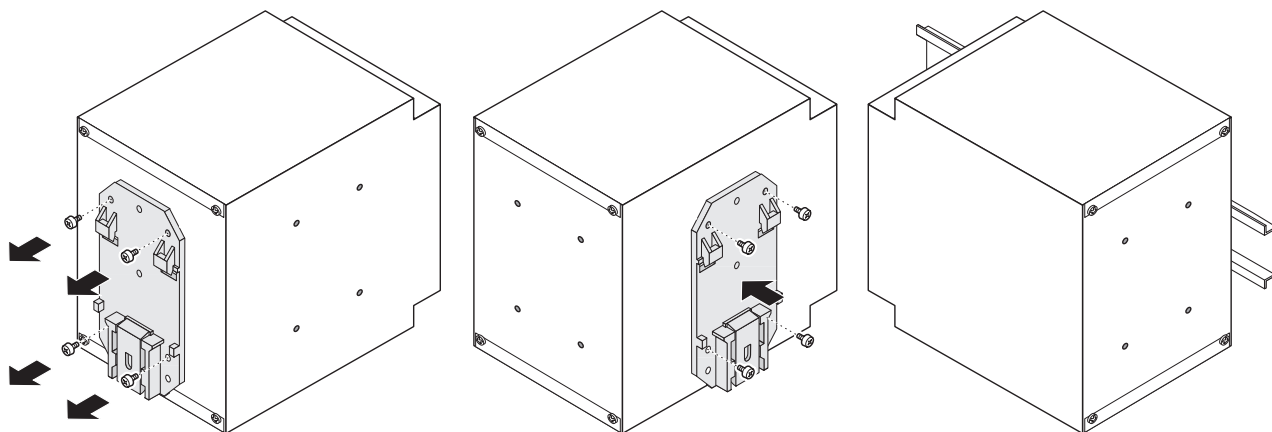

Figure 6 Mounting position rotated 90°

#### 8.4 Connection terminal blocks

Use a screwdriver with a suitable blade width for wiring. For a cross section and insulate the cable ends according to the reliable and touch-proof connection, use a suitable cable above-mentioned specifications.

Terminal block	Solid conductor [mm <sup>2</sup> ]	stranded conductor [mm <sup>2</sup> ]	AWG	Stripping length [mm]	Torque [Nm]	Torque [lb in]
DC input: +/-	0.5 ... 16	0.5 ... 16	8 ... 6	10	1.2 ... 1.5	15
DC output: +/-	0.5 ... 16	0.5 ... 16	8 ... 6	10	1.2 ... 1.5	15
Battery: +/-/signal	0.5 ... 16	0.5 ... 16	20 ... 6	10	1.2 ... 1.5	15
Signals: R1, R2/I <sub>N</sub>	0.2 ... 4	0.2 ... 2.5	24 ... 12	8	0.5 ... 0.6	5 ... 7

**UL 508:**

Copper cable; operating temperature > 75°C (ambient temperature < 55°C) and > 90°C (ambient temperature < 75°C).

**UL 60950:**

Use ferrules for flexible cables.

## 8.5 Installation of individual components

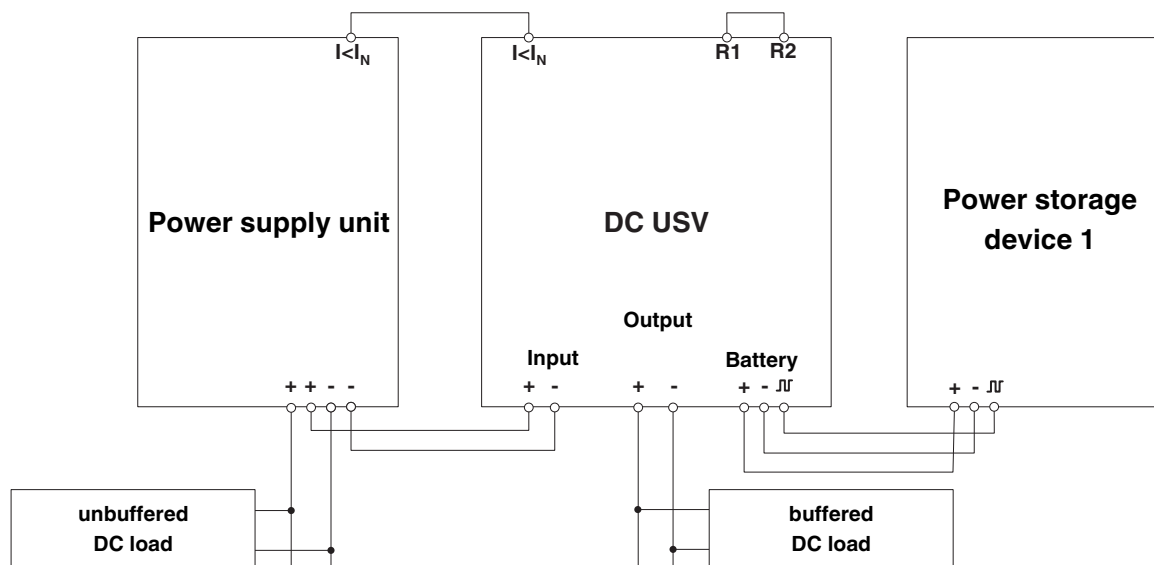

Figure 7 Schematic design



The image is a schematic representation of the design and does not contain all parts. Observe the installation instructions.

### Power supply unit

Use current-limited source (e. g., QUINT POWER power supply) or a suitable fuse. If loads must **not** be supplied in the event of a mains breakdown or failure, they must be connected directly to the output of the power supply as unbuffered DC load.

### DC UPS

- Input: the input is supplied with 18 ... 30 V DC.
- Output: in the event of mains interruption or failure, the connected DC load is supplied with voltage without interruption.
- Battery: the required power is made available by the power storage device. The signal cable is used for communication between the UPS and power storage device.
- Signal I<sub>I<sub>N</sub>: when connected to the I<sub>I<sub>N</sub> output of the QUINT POWER power supply unit, the power supply unit is charged with the maximum charging current as quickly as possible (fast battery charging). Supply of the buffered DC load always has priority. This function is available when the power supply unit makes a static power reserve available with corresponding signal contact e. g., QUINT POWER with POWER BOOST and preventive function monitoring. Without this, charging is performed at reduced current.
- Signal R1, R2: remote control

### Power storage device

Depending on the desired buffering time, select the power storage device listed under accessories.



VRLA power storage devices are temperature dependent. If possible and to ensure optimum function, install at a cool location e. g., at the bottom of the control cabinet.

## 9 Connection and protection

### 9.1 Input and protection of the primary side

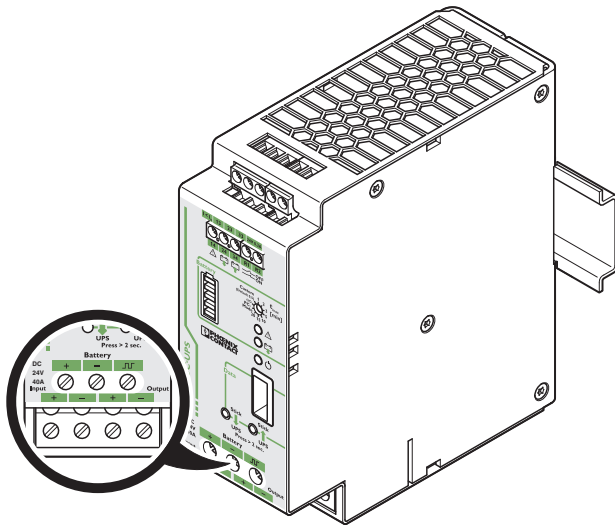

Figure 8 Input

Connection of the input is made via connection terminal blocks "Input +/-" (input reverse polarity protection).

The maximum current for each input is 53 A.

Therefore use a current-limited source (e. g., QUINT POWER) or a suitable fuse.

Installation of the device must correspond to EN 60950 regulations.

All cables must have large cross sections in order to keep voltage drops as small as possible.

### 9.2 Output and protection on the secondary side

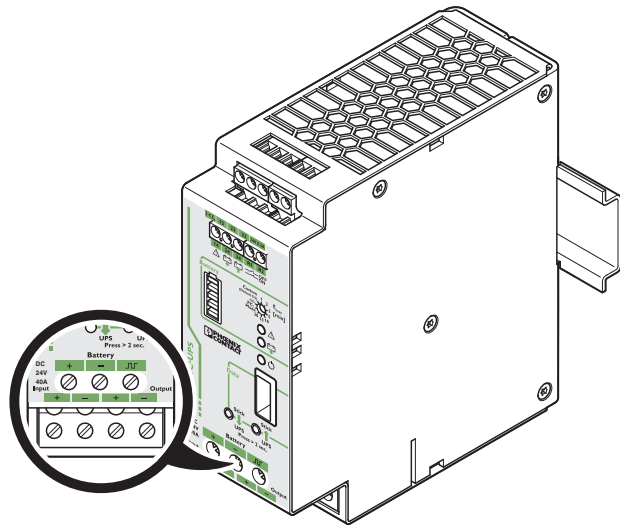

Figure 9 Output

Connection of the output takes place via the connection terminal block "Output +/-".

The device is electronically short-circuit-proof and idle-proof. In the event of a malfunction, the output voltage is limited to a maximum of 35 V DC. It must be ensured that all output cables are dimensioned or separately protected according to the maximum output current. All cables must have large cross sections in order to keep voltage drops as small as possible.

9.3 Power storage device

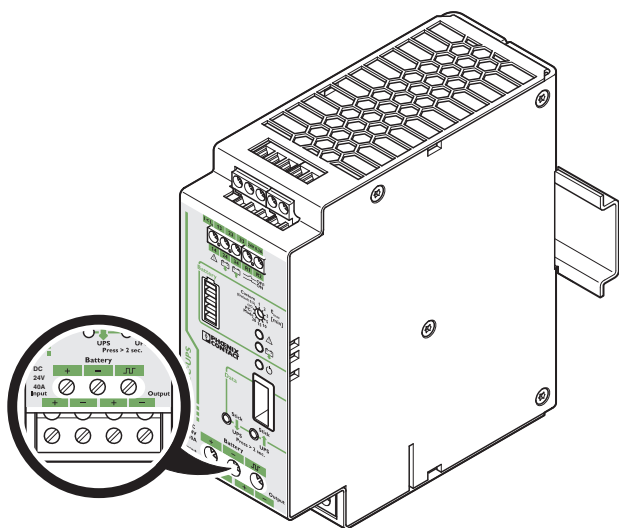

Figure 10 Output, battery

Connection of the power storage device takes place via the connection terminal block "Battery +/-". To make use of intelligent IQ technology, you must also install a cable for the communication between the UPS and power storage device.

You will find a clearly arranged selection table for suitable power storage devices next to the product at [www.phoenixcontact.net/catalog](http://www.phoenixcontact.net/catalog).

9.4 SFB technology

SFB (Selective Fuse Breaking) technology reliably switches off faulty current paths in the event of a short circuit. It supplies six times the nominal current for 12 ms in mains mode and for 15 ms in battery mode. SFB technology therefore safely triggers standard circuit breakers. Faults are located reliably and important system parts remain in operation.

9.5 Power reserves

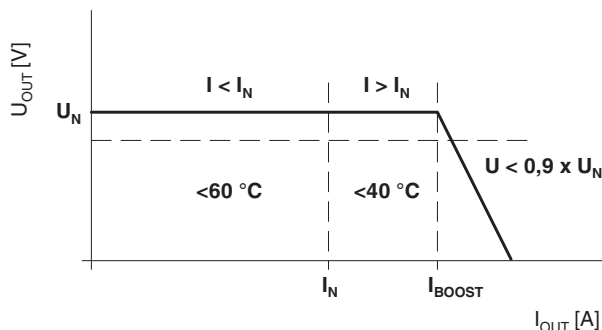

Figure 11 Output characteristic curve

Both the POWER BOOST static power reserve and the SFB (Selective Fuse Breaking) technology dynamic power reserve are available in mains and battery mode if a QUINT POWER power supply unit from Phoenix Contact is connected upstream.

In mains mode, the power reserve is forwarded to the buffered DC load via the UPS.

In battery mode, the power storage device supplies sufficient power to ensure the same behavior as a QUINT POWER power supply unit with SFB technology.

9.6 Temperature response

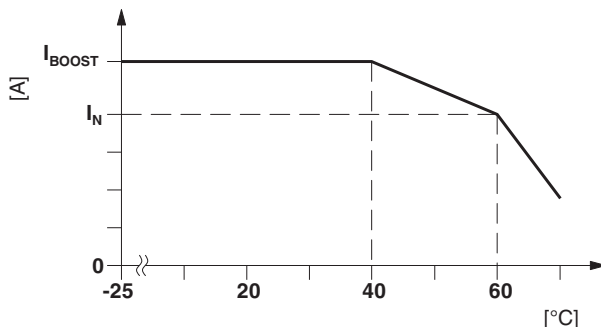

Figure 12 Derating diagram

At an ambient operating temperature of up to +40 °C, the UPS makes the I\_BOOST continuous output current available. The device can supply the I\_N nominal output current up to ambient temperatures of +60 °C. In the case of ambient temperatures above +60 °C, The output power must be decreased by 2.5 % per Kelvin temperature increase.

## 10 Signaling

Three LED indicators, an LED bar graph and three floating relay contacts are available for function monitoring.

In addition, you can use the UPS-CONF configuration and management software.



The software and the associated user manual are available free of charge at [www.phoenixcontact.net/catalog](http://www.phoenixcontact.net/catalog).

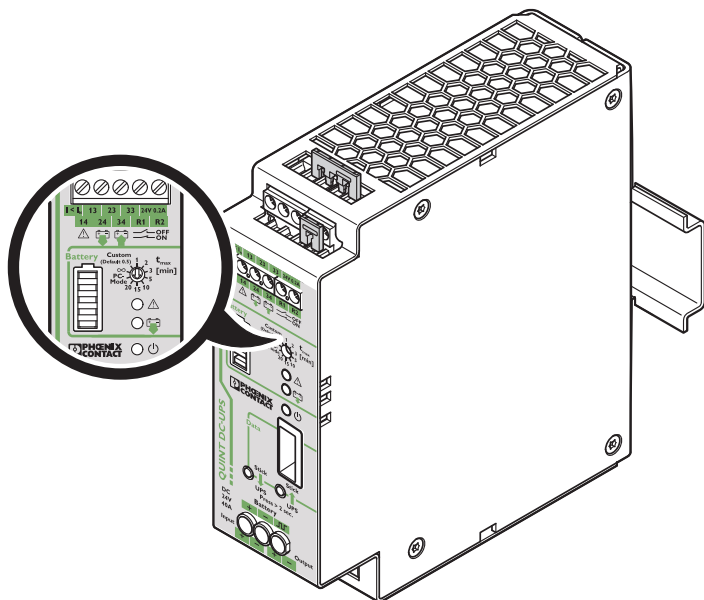

Figure 13 Display elements

State	LED	Switching output	Signal, default
Power In OK, mains mode	Green	-	-
Alarm	Red	13/14	Active low
Battery mode	Yellow	23/24	Active high
Battery charge	Bar graph	33/34	Active high

Alarms, warnings and/or operating states can be individually assigned to the battery mode and battery charge switching outputs via the UPS-CONF configuration and management software. Warnings are not indicated by the LED indicators.



**ATTENTION:**

LED indicator states are also simultaneously signaled via the switching outputs in the default settings. If an individual assignment of the switching outputs takes place, signal states deviating from the LED indicators are possible. Make sure that only sensible combinations are signaled.

## 10.1 LED and bar graph test

An LED test is performed automatically during startup of the device. The LEDs indicate the following error states:

1. All LEDs and the bar graph light up.
2. The LEDs light up, the bar graph does not light up, the lower bar changes its color from green to red.
3. All LEDs and the bar graph are off.
4. The LEDs and the bar graph light up according to their current status.

## 10.2 LED indicator

State	Green LED	Red LED	Yellow LED	Description
1	OFF	OFF	Lit	Battery mode, bar graph displays current charging state
2	OFF	Lit	Lit	Battery mode, power storage device is almost empty, lower bar graph LED is red
3	Lit	OFF	OFF	Mains mode, bar graph displays current charging state
4	Lit	Lit	OFF	Mains mode, alarm in the event of battery problem: lower bar graph LED flashes red

### Green LED (mains mode), yellow LED (battery mode)

Either the green or the yellow LED lights up.

Green LED lights up, yellow LED is off: the load connected to the UPS is supplied from the mains.

Green LED off, yellow LED lights up: mains is not available. The load connected to the UPS is supplied by the power storage device.

### Red LED, alarm in mains mode

Red LED lights up, the lower bar graph LED flashes red: there is a problem with the power storage device.

When using the UPS-BAT... power storage device and a connected communication cable, the current life expectancy (SOH, State of Health) is determined via the IQ technology. An alarm is signaled in the following cases:

- The adjustable threshold "remaining life expectancy" is reached.
- Different types of battery technology were connected that cannot be charged simultaneously, e. g. VRLA and LI-ION.
- The presence check is negative.
- The quality check is negative.

When using power storage devices other than UPS-BAT..., an alarm is signaled if it is not present or if the quality of the power storage device is no longer sufficient for supplying the load in the event of a mains failure.

If the lower bar graph LED does not flash, the alarm indicates overload or service mode.

### Red LED, alarm in battery mode

Red LED lights up: the power storage device is almost completely discharged.

When using the recommended UPS-BAT power storage device and connected communication cable, the current charging state (SOC, State of Charge), is displayed via the IQ technology. The preset alarm signaling threshold is 10%. The lower bar graph LED lights up red.

As an option, a time can be set via the UPS-CONF software, for example, 10 mins. In this case, the UPS signals an alarm when the power storage device is able to supply the connected load for a further 10 minutes.

When using power storage devices other than the UPS-BAT..., the alarm indicates battery voltage too low (default: 20.4 V).



#### ATTENTION:

Signaling of all states is determined by calculated, individual or preset thresholds and operating states. The detection that is the base of signaling takes place with high accuracy. However, detection is subject to the respective ambient conditions in each case. In particular power storage devices can contribute to further deviations, irrespective of the storage technology.

### **10.3 Bar graph-display when the communication cable is installed**

The current charging state and the remaining runtime of the power storage device is determined during startup of the UPS. The LED light lights up from bottom to top during this (charging the battery in mains mode) or from top to bottom (discharging the battery in battery mode).

When the power storage device is fully charged and the charging state is determined, this is displayed by the bar graph. Depending on the charging state and the size of the power storage device, this can range from a few minutes to hours.

Each LED corresponds to 20% of the total capacity. The lowest LED is divided into two parts: red for 0-10%, green for 11-20%.

The current capacity level is indicated by flashing during charging.

### **10.4 Bar graph display without communication cable**

If no communication cable is installed between the UPS and the power storage device, the LEDs indicate the following states during startup of the UPS in mains mode.

The upper 4 LEDs are off.

The lower LED can indicate the following states.

- Flashing: power storage device is being charged
- Off: power storage device is not being charged
- Red: battery problem

## 11 Function

In mains mode (DC input voltage present), the output voltage corresponds to the applied input voltage. In the event of a failure of the voltage supply, switching to battery mode takes place without interruption. The output voltage is not directly dependent on the battery voltage.

### 11.1 IQ technology

#### Intelligent Battery Management

- SOC (State of Charge): current charging state and remaining runtime of the power storage device is always available.
- SOH (State of Health): displays the remaining life expectancy of the power storage device and warns of failures at an early stage.
- SOF (State of Function): determines the current performance of the power storage device.

#### Intelligent Battery Control

Intelligent Battery Control – automatically detects the connected battery type via the connected communication cable and maximizes the remaining service life of the power storage device via an optimally adapted charging characteristic.

#### Intelligent Charging

The device adapts the charging current and thereby ensures the fastest possible recharging and maximum availability

#### Intelligent Communication

The data port is used for communication between the UPS and PC, e. g., for configuring the UPS.

### 11.2 SOC application example

**Task:** an industrial PC must be continuously supplied with 24 V DC.

**Previous solution:** the UPS is buffered with 3.4 Ah and supplies 24 V DC / 5 A for 20 under optimum conditions  
Minutes

**Problem:** can the power storage device actually bridge this time? Charging state, performance and remaining runtime of the battery are unknown.

#### Solution with IQ technology:

The intelligent UPS determines all relevant battery states. This ensures the transparency required to guarantee the stability of the supply and optimum use of the battery at all times.

The intelligent battery management detects the current charging state of the connected battery and uses this to calculate the remaining runtime.

The QUINT UPS-IQ also signals whether the buffer time is actually 20 minutes. As soon as an adjustable threshold value is

reached, the floating relay contact or the software generates a warning message or the PC is shut down. The industrial PC works for as long as possible and is shut down only if absolutely necessary.

### 11.3 SOH/SOF application example

**Task:** electrical loads in remote systems widely separated from each other must be continuously supplied with 24 V DC.

**Previous solution:** The user invests in a new battery every two years assuming that the system is reliably protected by this.

**Problem:** is the power storage device really 100% available for two years? Has the battery aged more quickly as a result of higher ambient temperatures and cannot deliver sufficient performance?

#### Solution with IQ technology:

The remaining life expectancy of the battery is known. This allows servicing to be planned. If the battery is replaced at the ideal time, costs are also avoided that would occur by replacing the battery too early or after failure. It is particularly important for applications that are widely separated from each other to ascertain whether the battery works reliably for another two years or only two months. For example, replacing power storage devices in offshore wind power plants is associated with high costs. Indication of the current life expectancy of the battery saves unnecessary labor and material costs.

## 11.4 Charging characteristic

When the recommended UPS-BAT... power storage device is used, the intelligent battery management of the UPS adapts itself to the respective connected storage technology such as Lithium or lead (VRLA – Valve Regulated Lead Acid) batteries. Additional settings of charging parameters are not necessary due to automatic detection.

The UPS is equipped with an integrated charging unit. Charging is performed according to the current battery state. By measuring the current temperature at the battery, temperature-compensated charging takes place. The intelligent battery management ensures fast availability and maximum service life of the power storage device. Depending on the performance class of the UPS, the integrated charging unit can have the following maximum charging current.

UPS	Max. charging current
5 A	1.36 A
10 A	2.88 A
20 A	5 A
40 A	5 A

The recharging time results from the maximum available charging current and the total capacity of the storage device type connected.

Charge control depends on the IUoU charging characteristic. This is a 3-stage charging process that is represented as follows.

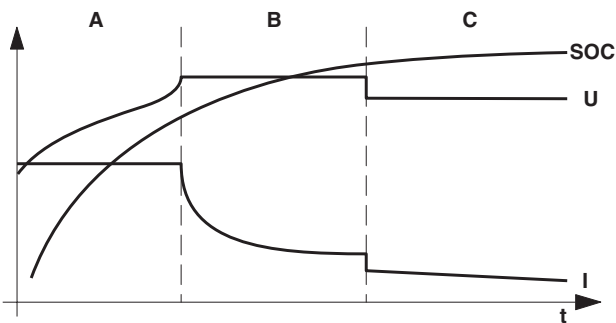

Figure 14 Charging curve

Stage	Name	Description
A	Main charge	Constant current charging phase (CC), initial charging current
B	Compensation charging	Constant voltage charging phase (CV), compensation trickle charge voltage
C	Trickle charging	Constant voltage charging phase (CV), trickle charging final voltage

If the communication cable between the UPS and the power storage device is interrupted, the temperature detected in the UPS module is used temporarily to ensure temperature compensation.

Temperature recording only takes place in the UPS module when using power storage devices other than the UPS-BAT.... In addition, adjustment and adherence to the charging parameters is necessary.

## 11.5 Fast battery charging, intelligent charging (contact $I < I_N$ )

The adaptive current management of the charging unit charges the power storage device considerably faster when the  $I < I_N$  input of the UPS is connected to the corresponding output of the power supply. This ensures shorter recharging times and the power storage device is available with full capacity much more quickly.

At the same time, the module supplies sufficient power for buffered DC loads. As long as the upstream connected power supply unit has sufficient power reserves, charging continues with high current. If the load requires a higher current, this is supplied at the highest priority. In this case the power storage device is charged more slowly.

The fast battery charging function is only available when the power supply unit makes a static power reserve available with corresponding signal contact, e. g., QUINT POWER with POWER BOOST and preventive function monitoring.

### 11.6 Setting the buffer time

You can set the time for exiting battery mode via the selection switch on the front of the device.

$t_{\max}$ [min] setting	Meaning
1, 2, 3, 5, 10, 15, 20	The UPS switches off after the set buffer time.
Custom (default 0.5)	The UPS switches off after the individual buffer time set via UPS-CONF.
≤ (unlimited, delivery state)	Buffering with the total stored power. A warning is generated as soon as the power storage device only has 10 % charge (default).
PC mode	In PC mode, it is possible to continue working with a PC after a mains failure, perform a controlled shutdown and restart automatically.

### 11.7 PC mode

In "PC mode", the UPS function follows a chronological sequence that can be parameterized via the software and individually optimized for the relevant application.

In the event of a mains failure, PC can continue to work, perform a controlled shutdown and restart automatically.



It is required that the following is installed:  
 IFS-USB-DATACABLE data cable (Order No. 2320500)  
 UPS-CONF software (Order No. 2320403, available free of charge at [www.phoenixcontact.net/catalog](http://www.phoenixcontact.net/catalog))  
 Communication cable between the UPS and the power storage device

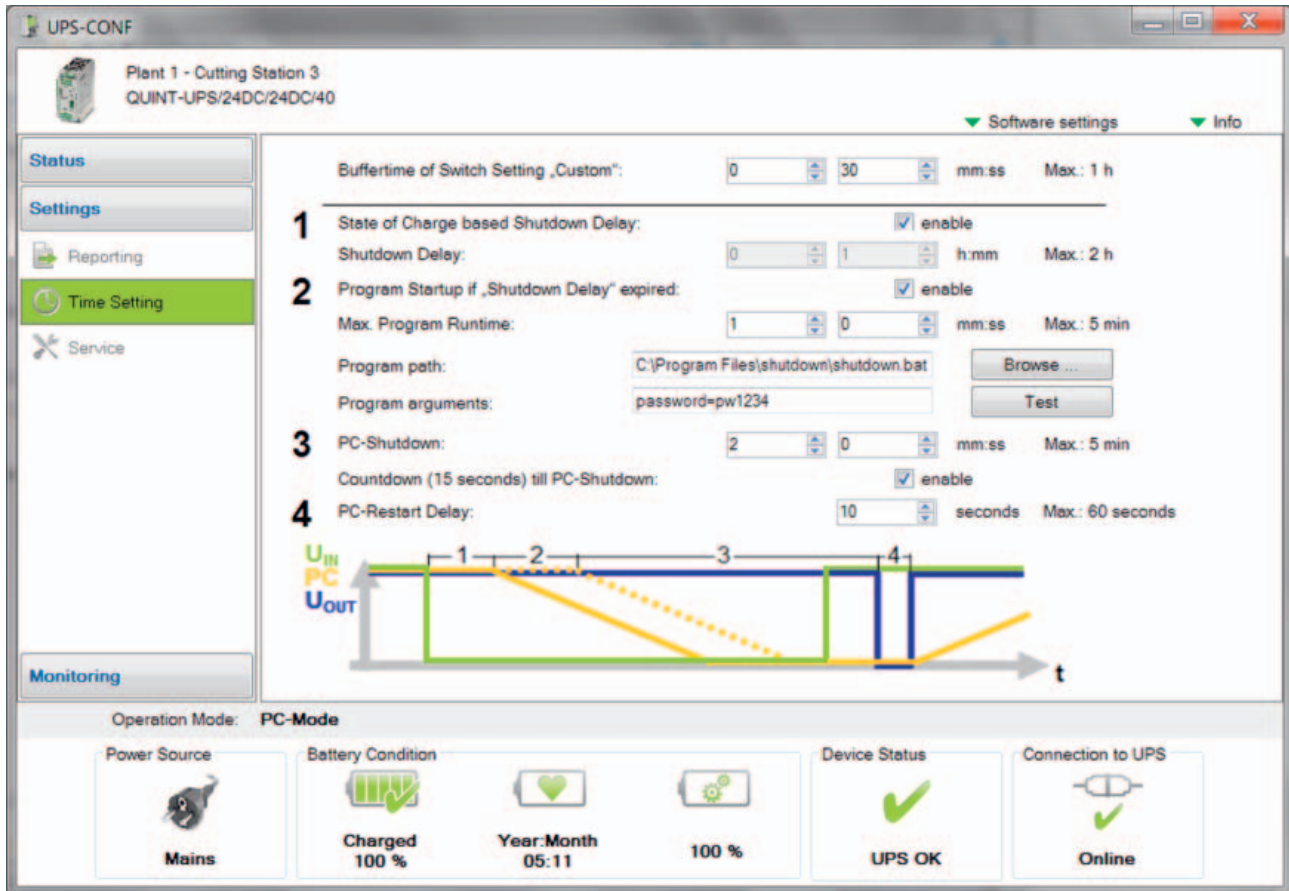

Figure 15 PC mode

### 1: Delay time

Delay time is calculated automatically from the current remaining battery life minus the time required by the PC to shut down. Alternatively, a fixed delay time may be chosen. Example: setting is 10 mins. and if mains power has not returned within 10 minutes, a corresponding alarm is signaled.

### 2: Program start

After the delay time has expired, it is possible to start a program.

Example: the software starts and begins successive back up of system data.

In the "PC-Mode" setting, on the selection switch of the UPS, the UPS function follows a chronological sequence that can be parameterized via the software and individually optimized for the relevant application

Menu: Settings > Time setting

### 3: PC shut-down

The time required for shutdown of the PC is set here.

### 4: PC idle time

The output voltage is interrupted during the reset time and the PC automatically restarted only if the PC is shut down and the mains returned in the mean time

### 11.8 Remote control (contact R1, R2)

The module can be switched on and off via a signal to contacts R1 / R2. Shutdown can take place in mains mode or while battery mode is active

#### Remote shutdown is deactivated

UPS in function (delivery state)

- The "R1" and "R2" terminal points are short circuited (delivery with plug-in bridge) OR 24 V DC is present at terminal point "R2".
- In the event of a voltage supply failure, the UPS switches over to battery mode.

#### Remote shutdown is activated

- The "R1" and "R2" terminal points are not short circuited AND 0 V is present at terminal point "R2".
- In the event of a voltage supply failure, the UPS does not switch over to battery mode and the device shuts down.

## 12 Interfaces

Optionally, you can the data port interface.

### 12.1 IFS-USB-DATACABLE

The module is connected via the data port to the USB port of the PC using the IFS-USB-DATACABLE.

The data cable between the PC and the UPS is necessary for parameterization and monitoring. It contains the interface electronics and electrical isolation.

### 12.2 IFS-CONFSTICK

The IFS-CONFSTICK is a multi-functional memory block for easy storage and backup of configuration and parameter data. You can copy the parameterization of one UPS to another UPS of the same type using the IFS-CONFSTICK.

#### Transferring UPS parameters to the IFS-CONFSTICK

1. Press the "UPS -> Stick" button and hold for at least 2 seconds.
2. Insert the IFS-CONFSTICK carefully into the "Data Port" of the UPS while observing the plug-in direction.
3. Parameter transfer is started and indicated by cyclic control of the three LED indicators. Light-up sequence: green/yellow/red
  - Error-free transfer: green LED indicator on
  - Transfer error: red LED indicator on

#### Transferring IFS-CONFSTICK parameters to the UPS

1. Press the "Stick -> UPS" button and hold for at least 2 seconds.
2. Insert the IFS-CONFSTICK carefully into the "Data Port" of the UPS while observing the plug-in direction.
3. Parameter transfer is started and indicated by cyclic control of the three LED indicators. Light-up sequence: green/yellow/red
  - Error-free transfer: green LED indicator on
  - Transfer error: red LED indicator on

## 13 Servicing

To switch to service mode, the following options are available:

- Button on the front of the UPS
- UPS-CONF software
- Service stick

Details can be found in the UPS-CONF user manual at [www.phoenixcontact.net/catalog](http://www.phoenixcontact.net/catalog).

### Replacing the battery

- Press and hold down both buttons on the front of the UPS longer than 6 s to switch to service mode. The red LED lights up.

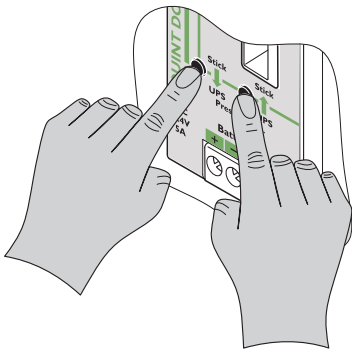

- Remove the fuses.

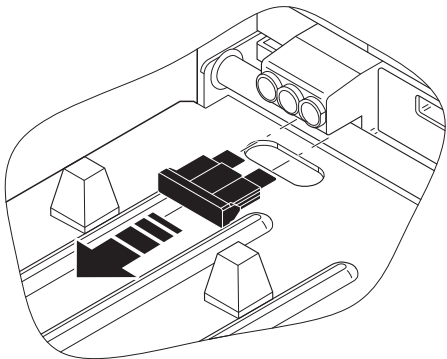

- Remove the cabling of the battery blocks.
- Remove the batteries.
- Install new batteries.
- Connect the cabling of the battery blocks.
- Insert the fuses.

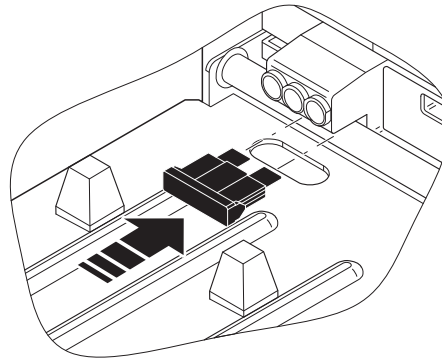

- Press and hold down both buttons on the front of the UPS for longer than 6 s to register the batteries. The bar graph flashes.

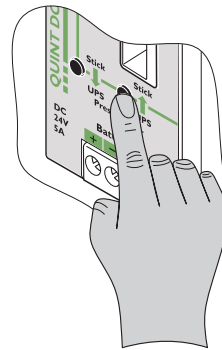

- Press and hold down both buttons on the front of the UPS for longer than 6 s to exit the service mode. The red LED extinguishes.

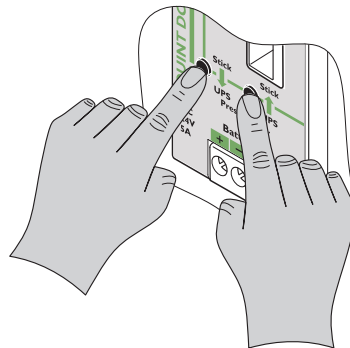

An exact description of the replacement procedure for all power storage devices can be found in the corresponding data sheet at [www.phoenixcontact.net/catalog](http://www.phoenixcontact.net/catalog).

## 14 Application examples

### 14.1 Parallel connection of the power storage devices

To increase the buffer time, a maximum of 15 power storage devices can be switched in parallel. It is recommended to keep the number as low as possible and use power storage devices with a higher capacity of necessary. For parallel operation, only use power storage devices with the same batch number .

After discharging of the power storage device, the recharging time depends on the maximum charging current that the UPS can make available.

Use a suitable fuse. Flat-type fuse inserts with the same nominal values from the battery used are recommended.

If possible, install at a cool location e. g., at the bottom of the control cabinet to ensure optimum function. For this, the following cabling design is advantageous.

Value	Description
$l_1$	Cable distance to the power storage device, to the node in the case of parallel connection, including fuse terminal block
$\text{mm}^2$	Conductor cross section to the power storage device
$l_2$	Cable distance between the power storage device and node

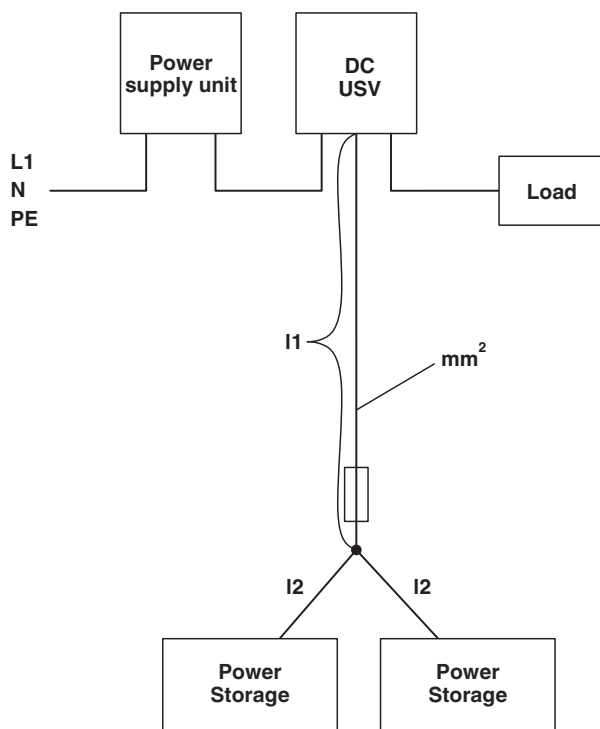

Figure 16 Parallel connection of the power storage devices in the control cabinet

## 14.2 Parallel connection for redundancy

Redundant circuits are suitable for supplying systems, which place particularly high demands on operational safety.

In order to set up a redundant power supply solution, two UPS systems of the same type (consisting of a power supply unit, DC-PS, redundant 1 .... n) are connected in parallel and de-coupled. No further adjustments to the default setting are necessary.

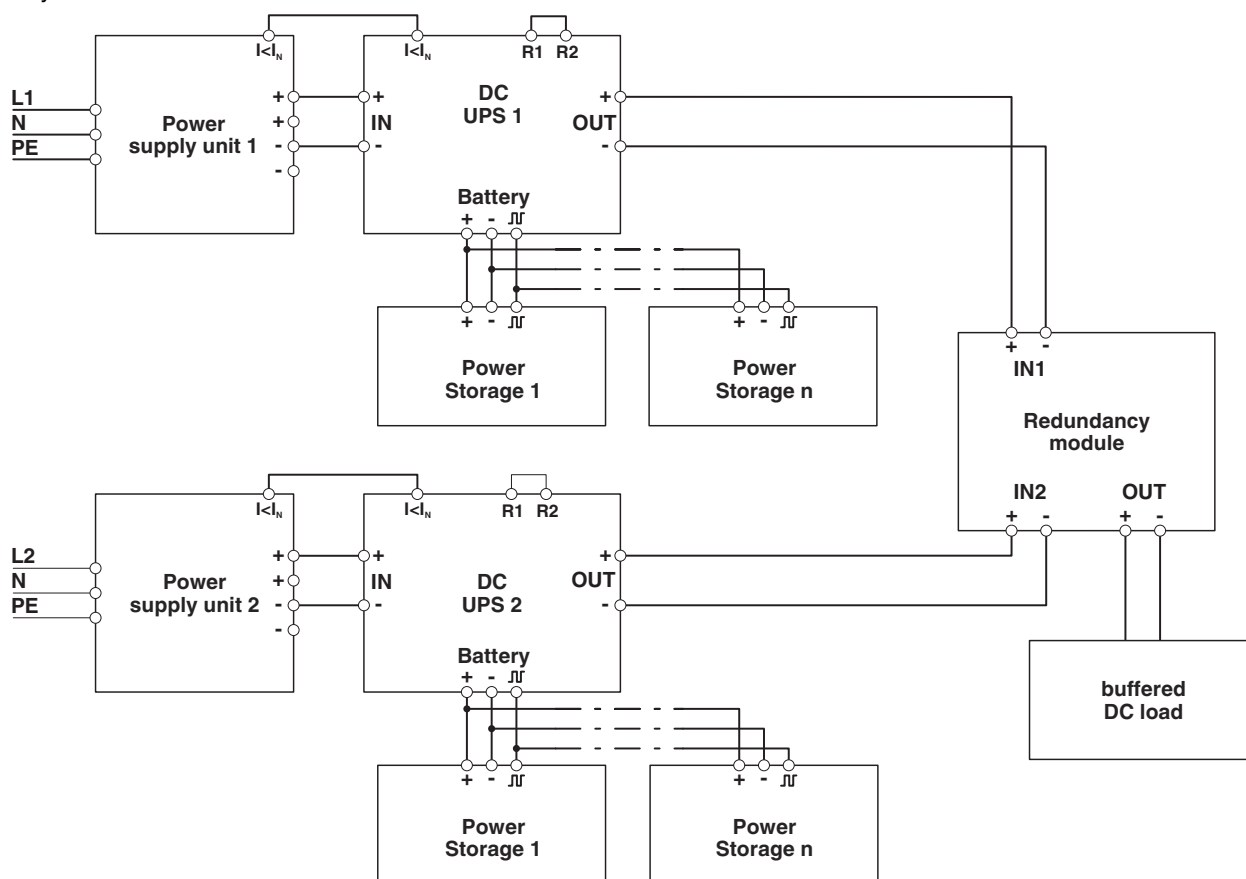

Figure 17 Parallel connection for redundancy

If a fault occurs in the first UPS system, the second UPS system automatically takes over the entire supply without interruption and vice versa. For this purpose, the UPS systems to be connected in parallel are dimensioned so that the total current requirements of all loads can be fully met by one UPS system.



# SCATTERGOOD & JOHNSON LTD

ELECTRICAL ENGINEERING & FLUID CONTROL DISTRIBUTORS

Est.1899

At Scattergood & Johnson Ltd, we pride ourselves on being a technical distributor to specialist industries.

Working with a range of quality product suppliers across a number of specialist markets, we are not your average 'box shifter' - we are your technical and supply chain partner.

We fully support every product we sell - for free! Our internal team and external sales engineers can answer any product or application question, no matter the complexity.

Backing up this technical ability is a range of 50,000+ products available from stock for nationwide next day delivery (same day if required!), or you can collect what you need from any of our trade counters around the UK.

Select your specialist interest below to learn more about how we can help.



Online, In Branch and On the Road - Scattergood & Johnson Ltd, there when you need us.

# [www.scatts.co.uk](http://www.scatts.co.uk)