

Uninterruptible power supply - QUINT-UPS/ 24DC/ 24DC/10/3.4AH - 2320267

Please be informed that the data shown in this PDF Document is generated from our Online Catalog. Please find the complete data in the user's documentation. Our General Terms of Use for Downloads are valid (<http://phoenixcontact.com/download>)



Uninterruptible energy supply with IQ technology and integrated energy storage for DIN rail mounting, input 24 V DC, output: 24 V DC/10 A, energy storage: lead AGM 3.4 Ah, incl. mounted UTA 107/30 universal DIN rail adapter

Product Description

UPS modules with integrated energy storage are particularly space saving: UPS module and energy storage are combined in one housing. It's just a case of connecting a power supply upstream.

Your advantages

- ✓ Easy handling thanks to automatic battery detection, tool-free battery replacement during operation, and communication via the IFS interface
- ✓ Reliable starting of difficult loads with the static POWER BOOST power reserve with up to 1.5 times the nominal current permanently
- ✓ Fast tripping of standard circuit breakers with SFB (selective fuse breaking) technology
- ✓ Device suitable for universal use thanks to comprehensive license package and extensive parameterization and diagnostics options



Key Commercial Data

Packing unit	1 pc
GTIN	 4 046356 554183
GTIN	4046356554183
Weight per Piece (excluding packing)	4,434.000 g
Custom tariff number	85371091
Country of origin	China

Technical data

Dimensions

Width	120 mm
Height	169 mm
Depth	125 mm

Ambient conditions

Degree of protection	IP20
----------------------	------

Uninterruptible power supply - QUINT-UPS/ 24DC/ 24DC/10/3.4AH - 2320267

Technical data

Ambient conditions

Ambient temperature (operation)	0 °C ... 40 °C
Ambient temperature (storage/transport)	-15 °C ... 40 °C
Max. permissible relative humidity (operation)	≤ 95 % (25 °C, non-condensing)
Climatic class	3K3 (in acc. with EN 60721)
Degree of pollution	2

Input data

Input voltage	24 V DC
Input voltage range	18 V DC ... 30 V DC
Current consumption (maximum)	18.6 A (24 V DC)
Current consumption (idle)	9.5 mA
Current consumption (charging process)	3.6 A

Output data (24 V DC mains operation)

Nominal output voltage	24 V DC
Output voltage range (depends on the input voltage)	18 V DC ... 30 V DC
Nominal output current (I_N)	10 A (0 °C ... 40 °C)
POWER BOOST (I_{Boost})	15 A (0 °C ... 40 °C)
Selective Fuse Breaking (I_{SFB})	60 A (0 °C ... 40 °C)

Output data (24 V DC battery operation)

Nominal output voltage	24 V DC
Output voltage range (depends on the input voltage)	19.2 V DC ... 27.6 V DC ($U_{OUT} = U_{BAT} - 0.5 \text{ V DC}$)
Nominal output current (I_N)	10 A (0 °C ... 40 °C)
POWER BOOST (I_{Boost})	15 A (0 °C ... 40 °C)
Selective Fuse Breaking (I_{SFB})	65 A (0 °C ... 40 °C)

General output data

Efficiency	> 97.6 % (Mains operation, with charged energy storage)
------------	---

General

IQ technology	Yes
Disposal	Used batteries must not be thrown away with household waste, they should instead be disposed of in accordance with applicable national regulations. They can also be returned to Phoenix Contact or the manufacturer.
Net weight	3.8 kg
Memory medium	Lead rechargeable battery module, 3.4 Ah
Protection class	III
MTBF (IEC 61709, SN 29500)	> 806000 h (40 °C)
Mounting position	horizontal DIN rail NS 35, EN 60715
Assembly instructions	alignable: horizontal 5 mm, vertical 50 mm

Uninterruptible power supply - QUINT-UPS/ 24DC/ 24DC/10/3.4AH - 2320267

Technical data

Connection data, input

Connection method	Pluggable screw connection
Conductor cross section solid min.	0.2 mm ²
Conductor cross section solid max.	2.5 mm ²
Conductor cross section flexible min.	0.2 mm ²
Conductor cross section flexible max.	2.5 mm ²
Conductor cross section AWG min.	16
Conductor cross section AWG max.	12
Stripping length	7 mm
Screw thread	M4

Connection data, output

Connection method	Pluggable screw connection
Conductor cross section solid min.	0.2 mm ²
Conductor cross section solid max.	2.5 mm ²
Conductor cross section flexible min.	0.2 mm ²
Conductor cross section flexible max.	2.5 mm ²
Conductor cross section AWG min.	16
Conductor cross section AWG max.	12
Stripping length	7 mm
Screw thread	M4

Connection data for signaling

Conductor cross section solid min.	0.2 mm ²
Conductor cross section solid max.	2.5 mm ²
Conductor cross section flexible min.	0.2 mm ²
Conductor cross section flexible max.	2.5 mm ²
Conductor cross section AWG min.	24
Conductor cross section AWG max.	12
Screw thread	M4

Standards

EMC requirements for noise immunity	EN 61000-6-1
	EN 61000-6-2
EMC requirements for noise emission	EN 61000-6-3
	EN 61000-6-4
Standard - Electrical safety	EN 60950-1/VDE 0805 (SELV)
Standard – Electronic equipment for use in electrical power installations and their assembly into electrical power installations	EN 50178/VDE 0160 (PELV)
Rail applications	EN 50121-4

Conformance/approvals

UL approvals	UL/C-UL Recognized UL 60950-1
--------------	-------------------------------

Uninterruptible power supply - QUINT-UPS/ 24DC/ 24DC/10/3.4AH - 2320267

Technical data

Conformance/approvals

	UL Listed UL 508
--	------------------

EMC data

Electromagnetic compatibility	Conformance with EMC Directive 2014/30/EU
Low Voltage Directive	Conformance with LV directive 2006/95/EC
Electrostatic discharge	EN 61000-4-2
Contact discharge	8 kV (Test Level 4)
Discharge in air	15 kV (Test Level 4)
Electromagnetic HF field	EN 61000-4-3
Frequency range	80 MHz ... 1 GHz
Test field strength	20 V/m
Frequency range	1 GHz ... 3 GHz
Test field strength	10 V/m
Frequency range	2 GHz ... 3 GHz
Test field strength	3 V/m
Comments	Criterion A
Fast transients (burst)	EN 61000-4-4
Input	2 kV (Test Level 3 - asymmetrical)
Output	2 kV (Test Level 3 - asymmetrical)
Signal	2 kV (Test Level 4 - asymmetrical)
Comments	Criterion A
Surge voltage load (surge)	EN 61000-4-5
Input	1 kV (Test Level 2 - symmetrical)
	2 kV (Test Level 3 - asymmetrical)
Output	1 kV (Test Level 2 - symmetrical)
	2 kV (Test Level 3 - asymmetrical)
Signal	1 kV (Test Level 2 - asymmetrical)
Comments	Criterion A
I/O/S	asymmetrical
Frequency range	0.15 MHz ... 80 MHz
Voltage	10 V (Test Level 3)
Comments	Criterion A
Criterion A	Normal operating behavior within the specified limits.
Criterion B	Temporary impairment to operational behavior that is corrected by the device itself.

Environmental Product Compliance

REACH SVHC	Lead 7439-92-1
China RoHS	Environmentally Friendly Use Period = 3

Uninterruptible power supply - QUINT-UPS/ 24DC/ 24DC/10/3.4AH - 2320267

Technical data

Environmental Product Compliance

	For details about hazardous substances go to tab "Downloads", Category "Manufacturer's declaration"
--	---

Drawings

Block diagram

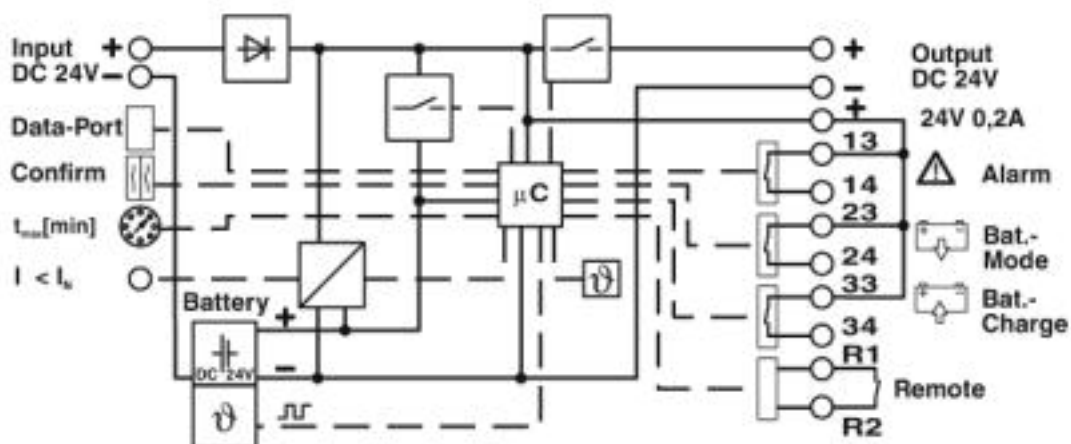

Classifications

eCl@ss

eCl@ss 4.0	27040600
eCl@ss 4.1	27040600
eCl@ss 5.0	27040600
eCl@ss 5.1	27040600
eCl@ss 6.0	27040600
eCl@ss 7.0	27040603
eCl@ss 8.0	27040603
eCl@ss 9.0	27040705

ETIM

ETIM 3.0	EC001039
ETIM 4.0	EC000382
ETIM 5.0	EC000382
ETIM 6.0	EC000382
ETIM 7.0	EC000382

UNSPSC

UNSPSC 6.01	30211510
UNSPSC 7.0901	39121011



Uninterruptible power supply - QUINT-UPS/ 24DC/ 24DC/10/3.4AH - 2320267

Classifications

UNSPSC

UNSPSC 11	39121011
UNSPSC 12.01	39121011
UNSPSC 13.2	39121011

Approvals

Approvals

Approvals

UL Listed / UL Recognized / cUL Recognized / cUL Listed / EAC / cULus Recognized / cULus Listed

Ex Approvals

UL Listed / cUL Listed / cULus Listed

Approval details

UL Listed		http://database.ul.com/cgi-bin/XYV/template/LISEXT/1FRAME/index.htm	FILE E 123528
-----------	---	---	---------------

UL Recognized		http://database.ul.com/cgi-bin/XYV/template/LISEXT/1FRAME/index.htm	FILE E 211944
---------------	---	---	---------------

cUL Recognized		http://database.ul.com/cgi-bin/XYV/template/LISEXT/1FRAME/index.htm	FILE E 211944
----------------	---	---	---------------

cUL Listed		http://database.ul.com/cgi-bin/XYV/template/LISEXT/1FRAME/index.htm	FILE E 123528
------------	---	---	---------------

EAC		EAC-Zulassung
-----	---	---------------

cULus Recognized	
------------------	---

<https://www.phoenixcontact.com/gb/products/2320267>



Uninterruptible power supply - QUINT-UPS/ 24DC/ 24DC/10/3.4AH - 2320267

Approvals

cULus Listed



Phoenix Contact 2019 © - all rights reserved
<http://www.phoenixcontact.com>



SCATTERGOOD & JOHNSON LTD

ELECTRICAL ENGINEERING & FLUID CONTROL DISTRIBUTORS

Est.1899

At Scattergood & Johnson Ltd, we pride ourselves on being a technical distributor to specialist industries.

Working with a range of quality product suppliers across a number of specialist markets, we are not your average 'box shifter' - we are your technical and supply chain partner.

We fully support every product we sell - for free! Our internal team and external sales engineers can answer any product or application question, no matter the complexity.

Backing up this technical ability is a range of 50,000+ products available from stock for nationwide next day delivery (same day if required!), or you can collect what you need from any of our trade counters around the UK.

Select your specialist interest below to learn more about how we can help.



Online, In Branch and On the Road - Scattergood & Johnson Ltd, there when you need us.

www.scatts.co.uk