

QUINT-BUFFER/24DC/24DC/40

Buffer module

Data sheet
105496_en_01

© PHOENIX CONTACT 2013-11-01



1 Description

The QUINT BUFFER buffer module combines the electronic switchover unit and power storage in the same housing. The buffer module stores the power required to bridge mains failures in maintenance-free capacitors.

Depending on the load current required, long mains buffering in the range from 200 ms at 40 A to 8 s at 1 A is possible. SFB (selective fuse breaking) technology can be used to trip standard circuit breakers quickly and reliably. Faulty current paths are switched off selectively, the fault is located, and important system parts remain in operation.

Features

Maximum system availability

- Long mains buffering from 200 ms at 40 A to 8 s at 1 A load current
- Using SFB technology, circuit breakers are tripped quickly and important system parts remain in operation
- Wide temperature range from -20°C to +80°C
- High MTF > 900,000 h (40°C)

Flexible use

- In auto mode which is optimized for QUINT power supplies
- Manually adjustable activation thresholds for applications using transformers or for long cable lengths

Saves space

- Space-saving electronic switchover unit and power storage in the same housing



Make sure you always use the latest documentation.
It can be downloaded from the product at phoenixcontact.net/products.

2	Table of contents	
1	Description	1
2	Table of contents	2
3	Ordering data	3
4	Technical data	3
5	Safety regulations and installation notes.....	7
6	Structure	8
7	Basic circuit diagram	8
8	Installation	9
	8.1 Mounting on a DIN rail	9
	8.2 Normal mounting position	9
	8.3 Removal.....	9
	8.4 Mounting position rotated 90°	9
	8.5 Convection.....	10
	8.6 Dimensional drawing	11
9	Device connection terminal blocks	12
	9.1 DC input	12
	9.2 DC output	12
	9.3 Power Good signal output.....	12
	9.4 Power Good status LED	12
	9.5 Rotary selector switch (activation threshold).....	13
10	Function.....	16
	10.1 Buffer time extension	16
11	Derating.....	16
12	Application example	17
	12.1 Parallel connection of buffer modules	17

3 Ordering data

Description	Type	Order No.	Pcs. / Pkt.
QUINT buffer module with maintenance-free capacitor-based power storage for DIN rail mounting, input: 24 V DC, output: 24 V DC/40 A, with integrated SFB (selective fuse breaking) technology, including mounted universal DIN rail adapter UTA 107	QUINT-BUFFER/24DC/24DC/40	2320393	1

Accessories	Type	Order No.	Pcs. / Pkt.
Universal DIN rail adapter	UTA 107	2853983	5
Universal wall adapter	UWA 182/52	2938235	1
Assembly adapter for QUINT POWER 10A on S7-300 rail	QUINT-PS-ADAPTERS7/2	2938206	1



Our range of accessories is being continually extended, our current range can be found in the download area.

4 Technical data

Input data	
Input voltage	24 V DC
Input voltage range DC	18 V DC ... 30 V DC
Buffer period	0.2 s (40 A) ... 8 s (1 A)
Connect threshold (fixed, variable)	< 20 V DC (< 22 V; < 24 V; < 26 V) ($U_{IN} - 1$ V)/0.1 s
Current consumption	0.1 A (No-load) 0.7 A (charging process)
Protective circuit	Transient surge protection

Output data	
Nominal output voltage	24 V DC (depending on the input voltage)
Output voltage in relation to the activation threshold	22 V DC ... 28.5 V DC
Buffer voltage	$U_{IN} - 0.8$ V and > 20 V
Output current	40 A 120 A (SFB technology, 12 ms)
Output current limit	45 A (According to current limitation of the power supply connected upstream)
Max. transit current	45 A (40 °C) 40 A (80 °C)
Efficiency	> 99 % (with charged power storage device)
Connection in parallel	Yes, for increasing the buffer time and for redundancy
Connection in series	No

Power consumption	
Power loss	8 W (Normal operation) 48 W (buffer mode)

Power Good signal output active (high = buffer module charged)

Output description	Power Good
Voltage/current	+ 24 V / 20 mA
Status display	LED "Power Good", green / Buffer module is loaded: LED ON

General data

Memory medium	Electrolytic capacitor
Insulation voltage input, output / housing	500 V
Degree of protection	IP20
Protection class	III
MTBF (EN 29500, 40°C)	> 902725 h
Side element version	Aluminum (AlMg3)
Hood version	Galvanized sheet steel, free from chrome (VI)
Mounting position	horizontal DIN rail NS 35, EN 60715
Dimensions W / H / D (state of delivery)	64 mm / 130 mm / 125 mm
Dimensions W / H / D (90° turned)	122 mm / 130 mm / 67 mm
Weight	1.1 kg

Ambient conditions

Ambient temperature (operation)	-25 °C ... 80 °C
Ambient temperature (storage/transport)	-40 °C ... 85 °C
Max. permissible relative humidity (operation)	≤ 95 % (at 25 °C, no condensation)
Vibration (operation)	< 15 Hz, amplitude ±2.5 mm (according to IEC 60068-2-6) 15 Hz ... 150 Hz, 2.3g, 90 min.
Shock	30 g in each direction, according to IEC 60068-2-27
Pollution degree	2
Climatic class	3K3 (in acc. with EN 60721)

Standards

Electrical Equipment for Machinery	EN 60204
Safety transformers for power supply units	EN 61558-2-17
Electrical safety (of information technology equipment)	EN 60950-1/VDE 0805 (SELV)
Electronic equipment for use in electrical power installations	EN 50178/VDE 0160 (PELV)
SELV	EN 60950-1 (SELV) and EN 60204 (PELV)
Safe isolation	DIN VDE 0106-101

Approvals

UL	UL/C-UL Recognized UL 60950 UL Listed UL 508 UL ANSI/ISA-12.12.01 Class I, Division 2, Groups A, B, C, D (Hazardous Location)
----	---



Conformance with EMC Directive 2004/108/EC			
Noise immunity according to EN 61000-6-2			
		EN 61000-6-2 requirement	Tested
Electrostatic discharge EN 61000-4-2			
	Housing contact discharge	4 kV (Test intensity 2)	8 kV (Test intensity 4)
	Housing air discharge	8 kV (Test intensity 3)	15 kV (Test intensity 4)
	Comments	Criterion B	Criterion A
Electromagnetic HF field EN 61000-4-3			
	Frequency range	80 MHz ... 1 GHz	80 MHz ... 1 GHz
	Test field strength	10 V/m	20 V/m
	Frequency range	1.4 GHz ... 2 GHz	1 GHz ... 6 GHz
	Test field strength	3 V/m	10 V/m
	Comments	Criterion A	Criterion A
Fast transients (burst) EN 61000-4-4			
	Input	2 kV (Test intensity 3 - asymmetrical)	2 kV (Test intensity 3 - asymmetrical)
	Output	2 kV (Test intensity 3 - asymmetrical)	2 kV (Test intensity 3 - asymmetrical)
	Signal	1 kV (Test intensity 3 - asymmetrical)	2 kV (Test intensity 4 - asymmetrical)
	Comments	Criterion B	Criterion A
Surge current loads (surge) EN 61000-4-5			
	Input	0.5 kV (Test intensity 1 - symmetrical) 0.5 kV (Test intensity 1 - asymmetrical)	1 kV (Test intensity 2 - symmetrical) 2 kV (Test intensity 3 - asymmetrical)
	Output	0.5 kV (Test intensity 1 - symmetrical) 0.5 kV (Test intensity 1 - asymmetrical)	1 kV (Test intensity 2 - symmetrical) 2 kV (Test intensity 3 - asymmetrical)
	Signal	1 kV (Test intensity 2 - asymmetrical)	1 kV (Test intensity 2 - asymmetrical)
	Comments	Criterion B	Criterion A
Conducted interference EN 61000-4-6			
	Input/Output/Signal	asymmetrical	asymmetrical
	Frequency range	0.15 MHz ... 80 MHz	0.15 MHz ... 80 MHz
	Voltage	10 V (Test intensity 3)	10 V (Test intensity 3)
	Comments	Criterion A	Criterion A
Criterion A			
		Normal operating behavior within the specified limits.	
Criterion B			
		Temporary impairment to operational behavior that is corrected by the device itself.	

Emitted interference in acc. with EN 61000-6-3

Radio interference voltage in acc. with EN 55011

EN 55011 (EN 55022) Class B, area of application: Industry and residential

Emitted radio interference in acc. with EN 55011

EN 55011 (EN 55022) Class B, area of application: Industry and residential



All technical specifications are nominal and refer to a room temperature of 25 °C and 70% relative humidity at 100 m above sea level.



Current approvals/permissions for the product can be found in the download area under phoenixcontact.net/products.

5 Safety regulations and installation notes

**EXPLOSION HAZARD!**

Only remove equipment when it is disconnected and not in the potentially explosive area.

DANGER

Never carry out work on live parts!
The housing can become very hot, depending on the ambient temperature and load!

**CAUTION:**

Before startup please ensure:

The connection must be carried out by a competent person and protection against electric shock guaranteed.

It must be possible to switch off power to device according to EN 60950.

All feed lines are sufficiently protected and dimensioned!

All output lines are dimensioned according to the maximum output current of the device or separately protected!

Sufficient convection must be guaranteed.

Observe mechanical and thermal limits.

**NOTE: Danger if used improperly**

The buffer modules are built-in devices. Installation and startup may only be carried out by qualified personnel. The relevant country-specific regulations must be observed.

**CAUTION: Risk of injury**

Cover termination area after installation in order to avoid accidental contact with live parts (e. g., installation in control cabinet).

6 Structure

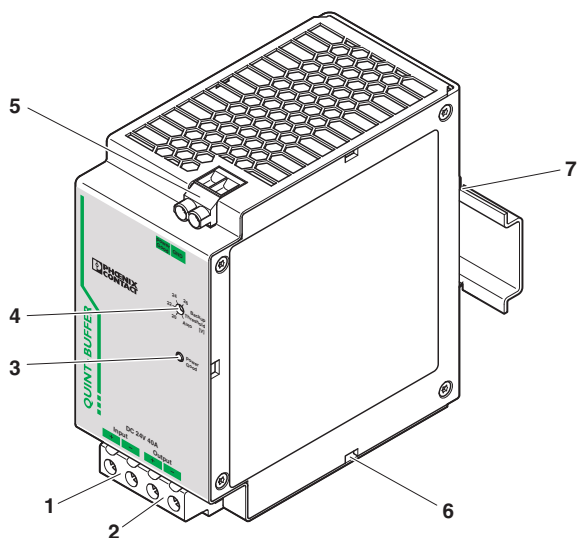
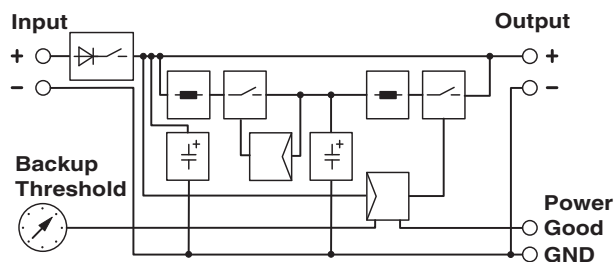

Figure 1 Position of the function elements

1 Strain relief for connecting cables

No.	Connection terminal blocks and function elements
1	DC input
2	DC output
3	Power Good signal LED, green
4	Rotary selector switch for setting the switchover threshold (buffer mode)
5	Active signal output (Power Good)
6	Strain relief for connecting cable
7	Universal DIN rail adapter

7 Basic circuit diagram



Element	Meaning
	Rectification
	Rotary selector switch
	Inductance
	Capacitance
	Switch
	Controller

8 Installation

8.1 Mounting on a DIN rail



Observe the required locked areas in order to ensure correct operation of the device.

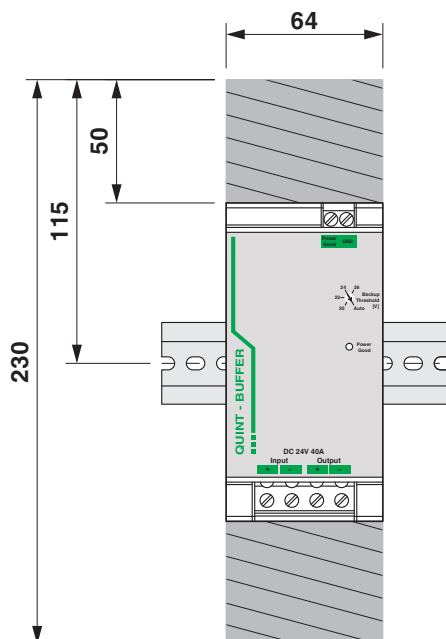

Figure 2 Installation dimensions and locked areas

8.2 Normal mounting position



Installation depth: 125 mm (+ DIN rail)

Position the module with the DIN rail guide on the upper edge of the DIN rail, and snap it in with a downward motion.

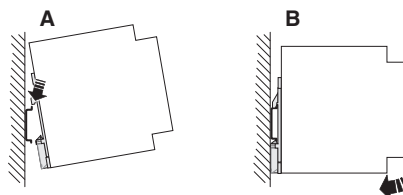

Figure 3 Assembly

8.3 Removal

Pull the snap lever open with the aid of a screwdriver and slide the module out at the lower edge of the DIN rail.

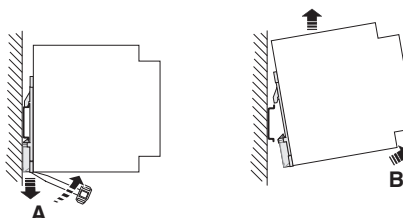

Figure 4 Removal

8.4 Mounting position rotated 90°



Installation depth: 67 mm (+ DIN rail)

For a mounting position rotated at 90° to the DIN rail, mount the DIN rail adapter (UTA 107) as shown in the figure. No additional assembly material is required. Mounting screws: Torx® T10 (0.8 Nm ... 0.9 Nm tightening torque).

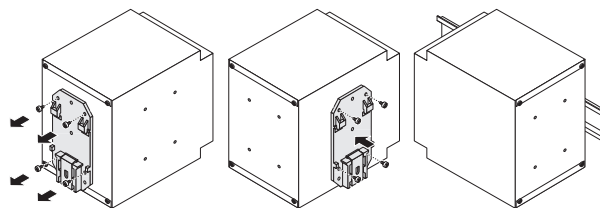

Figure 5 Schematic view of UTA change

8.5 Convection

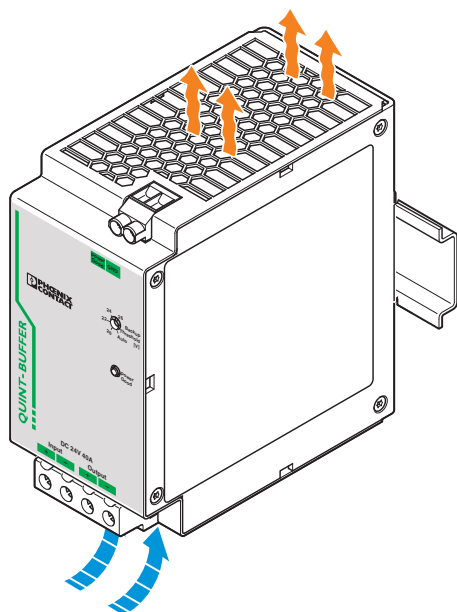

Figure 6 Convection



NOTE: enable convection

The housing can become very hot, depending on the ambient temperature and module load.

NOTE: Spacing when mounting

The module can be aligned: 0 mm horizontally, 50 mm vertically



The device can be snapped onto all DIN rails in accordance with EN 60715 and should be mounted in the normal mounting position (connection terminal blocks on top and bottom).

8.6 Dimensional drawing

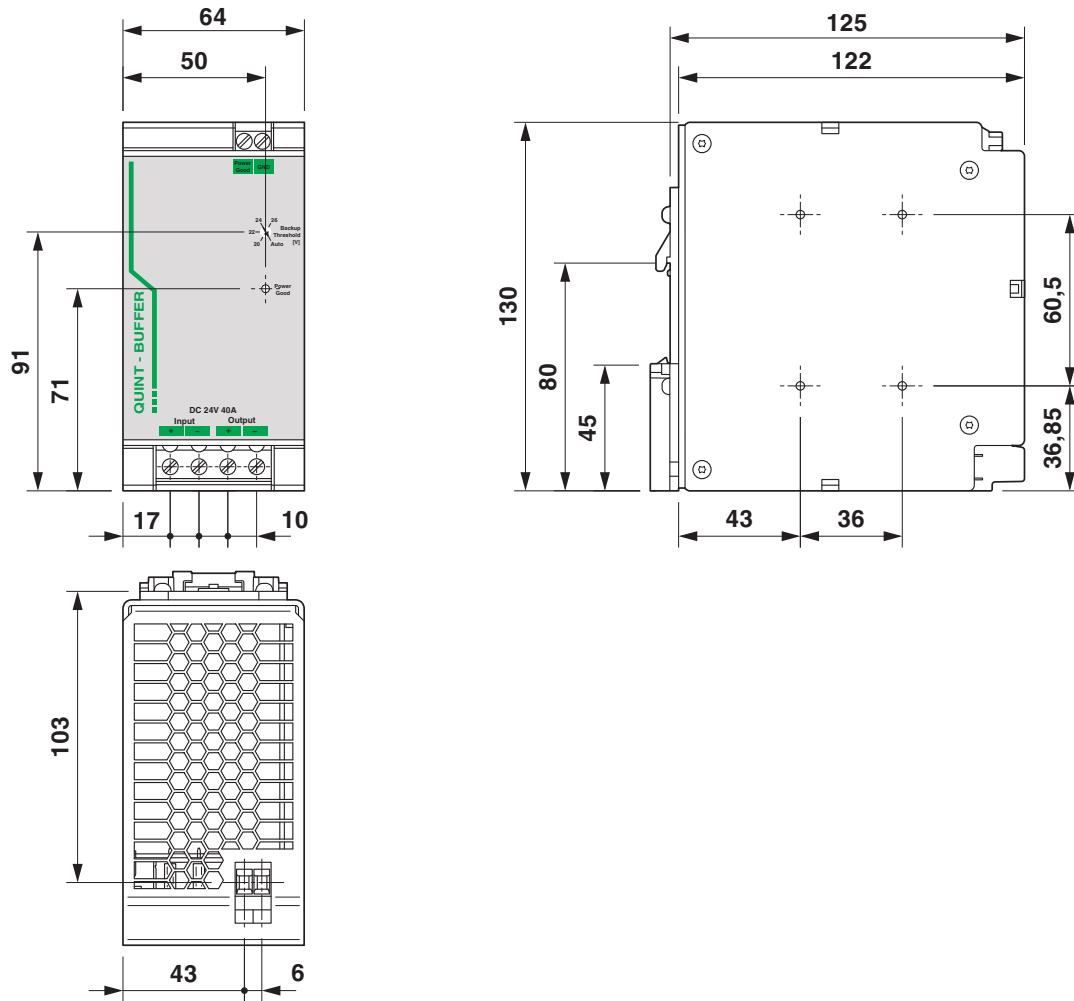

Figure 7 Device dimensions

9 Device connection terminal blocks



Observe the correct polarity when connecting the device.

9.1 DC input

The device is supplied with power via the input +/- screwable device connection terminal blocks of the 24 V DC input.

Connect a suitable power supply which can supply sufficient current to power the device in buffer mode.



Minimum requirement:
QUINT POWER SUPPLY SFB with a nominal output current from 10 A or higher.

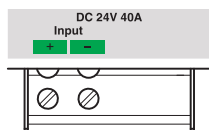

Figure 8 Input connection terminal blocks

9.2 DC output

In buffer mode, the load is supplied via the output +/- screwable device connection terminal blocks. The internal diode ensures that the unbuffered load (2-pos.) is decoupled from the buffered load (4-pos.).

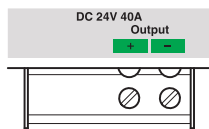

Figure 9 Output connection terminal blocks

9.3 Power Good signal output

The active signal output can be used to forward data to a higher-level control system. The signal output is activated for the duration of buffer mode and can carry a maximum of 24 V DC/20 mA.

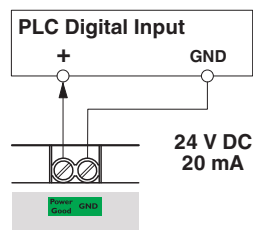

Figure 10 Power Good connection terminal blocks

9.4 Power Good status LED

The current device status can be determined at any time via the green Power Good status LED. Depending on the relevant device status, the green Power Good LED is either on, flashing or deactivated.

Power Good status LED			
	ON	Flashing	OFF
	Power Good signal high	Power Good signal low	
Normal operation	UIN = OK	QUINT BUFFER is charging	
	QUINT BUFFER is charged		
Buffer mode		Power is output to the load	QUINT BUFFER is discharged



Figure 11 Power Good status LED

9.5 Rotary selector switch (activation threshold)

The rotary selector switch on the front of the device is used to set the required activation threshold for buffer mode. A suitable screwdriver is required for this.



To ensure that the correct activation threshold is also observed, the rotary selector switch should only be modified when the device is disconnected from the power supply.

Select the required operating mode according to the table below.

Rotary selector switch	Buffer mode activated at	Mains operation activated at
U_{IN} 20 V DC	19.2 V DC	20 V DC
U_{IN} 22 V DC	21.2 V DC	22 V DC
U_{IN} 24 V DC	23.2 V DC	24 V DC
U_{IN} 26 V DC	25.2 V DC	26 V DC
Auto	$U_{IN} - 1$ V DC	$U_{IN} > (U_{IN} - 1$ V DC)



Auto mode should preferably be selected in the case of large distances between the buffer module and load. In this operating mode, the cable-related voltage drop is compensated by automatically adjusting the supply voltage.



In auto mode, the average value for determining the activation threshold is calculated over the last five seconds.

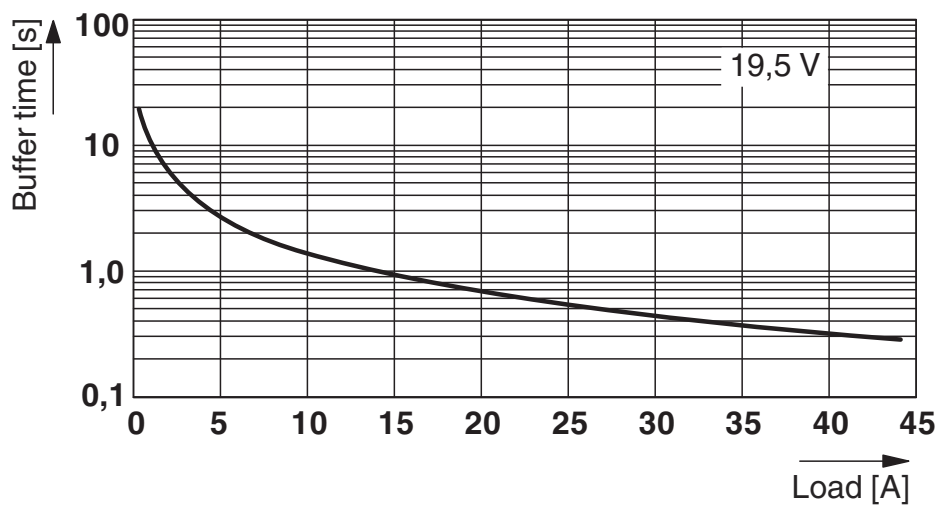
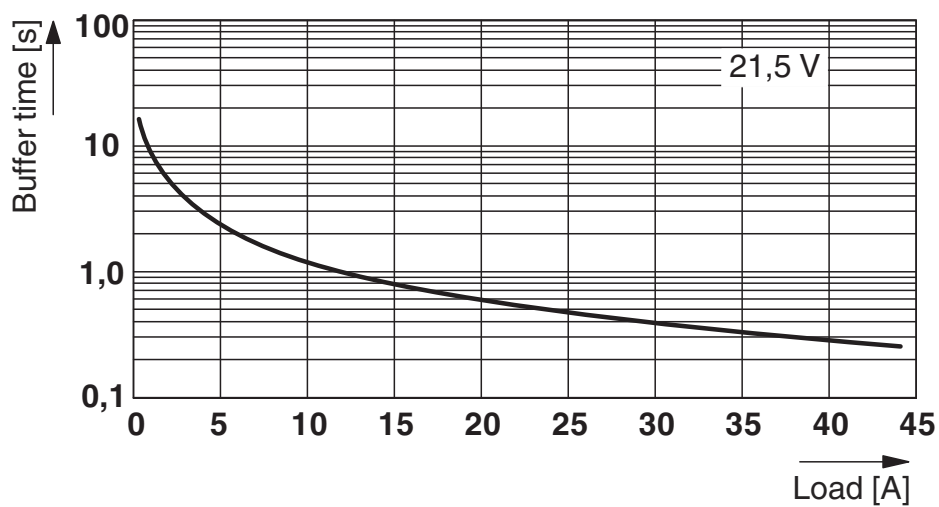

Figure 12 Rotary switch in automatic mode

Example 1: buffer time in U_{IN} 20 V mode**Example 2: buffer time in U_{IN} 22 V mode**

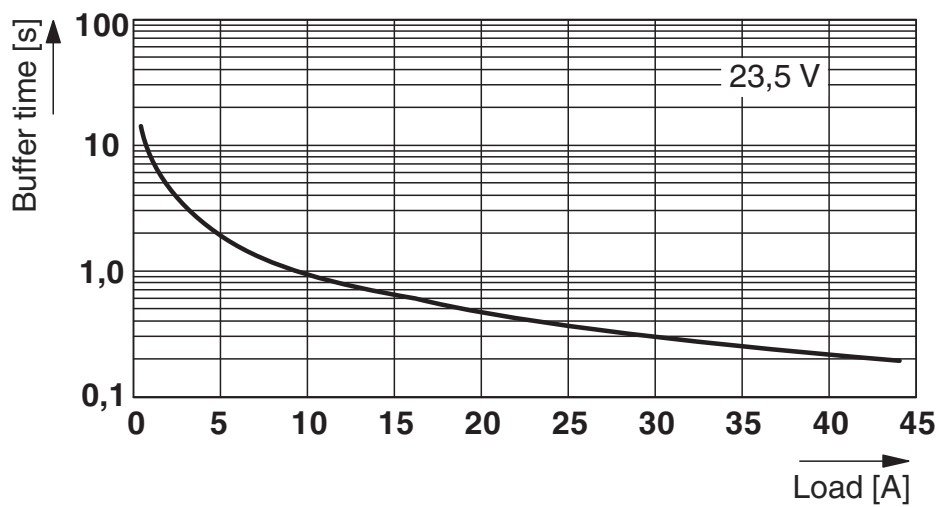
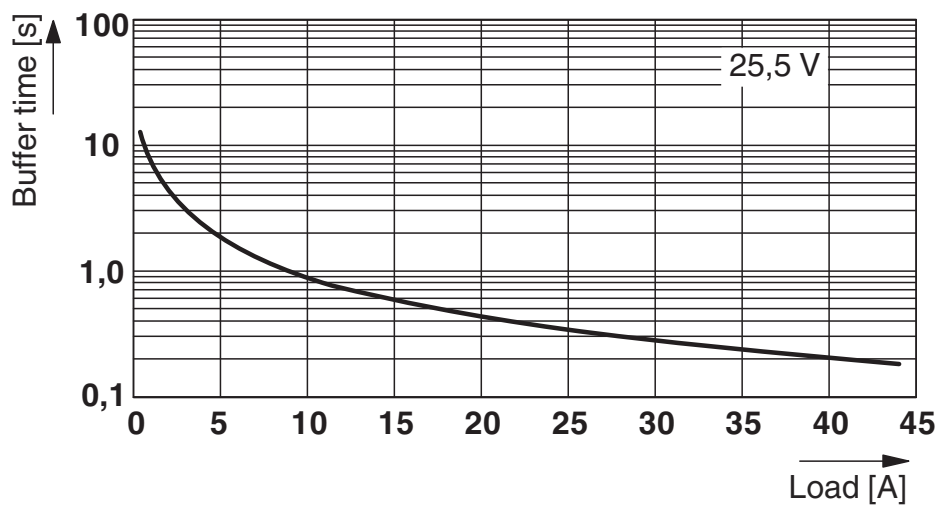
Example 3: buffer time in U_{IN} 24 V mode**Example 3: buffer time in U_{IN} 26 V mode**

10 Function

The device supplies a regulated and uninterruptible 24 V DC voltage, for a maximum load current of 40 A, at the output for all connected loads. When the supply voltage is connected, the integrated power storage is charged. In the event of supply voltage failure, the connected load is supplied with power without interruption.

Depending on the load current required, long mains buffering in the range from 200 ms at 40 A to 8 s at 1 A is possible.

Buffer mode is indicated by a flashing signal LED and active signal output.

Example:

The device is operated by the power supply connected upstream with an input voltage of 27 V DC. Auto mode is set with the rotary selector switch.

The average value of the input voltage is steadily determined over the course of the last five seconds. The device uses this to determine the required activation threshold for buffer mode and the switching threshold for mains operation.

Activation of buffer mode/mains operation

The device detects a voltage dip > 1 V DC compared to the previous input voltage at the input DC input terminal blocks. Buffer mode remains active until the input voltage reaches the switching threshold for mains operation again.

10.1 Buffer time extension

With the decoupled input, connected loads can be divided into unbuffered loads (2-pos.) and buffered loads (4-pos.).

The following options are available for extending the buffer time:

- Since the buffer time is directly dependent on the load current provided, only critical loads should be protected (4-pos.).
- A maximum of five buffer modules can be connected in parallel to increase the storage capacity.



In parallel operation, the same activation threshold must be set at each of the buffer modules.

11 Derating



There is no voltage or position-dependent derating.

12 Application example

12.1 Parallel connection of buffer modules

To increase the buffer time, a maximum of five buffer modules can be connected in parallel. After discharging the buffer modules, the required recharging time depends on the remaining charge available at the buffer modules and the maximum charging current that the power supply connected upstream can provide.



When wiring several buffer modules, the same cable cross sections and cable lengths should always be used.



For the parallel connection of buffer modules, the same activation threshold must be set at each power storage.

Operation as 2-pos. (load not decoupled from the input)

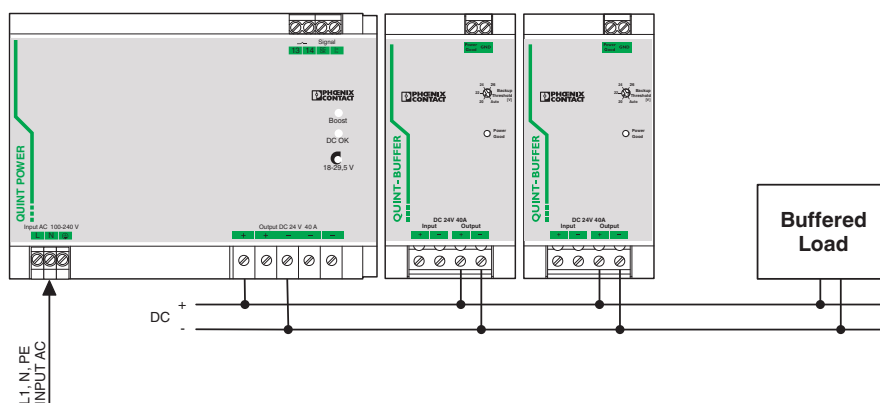

Operation as 4-pos. (load not decoupled from the input)

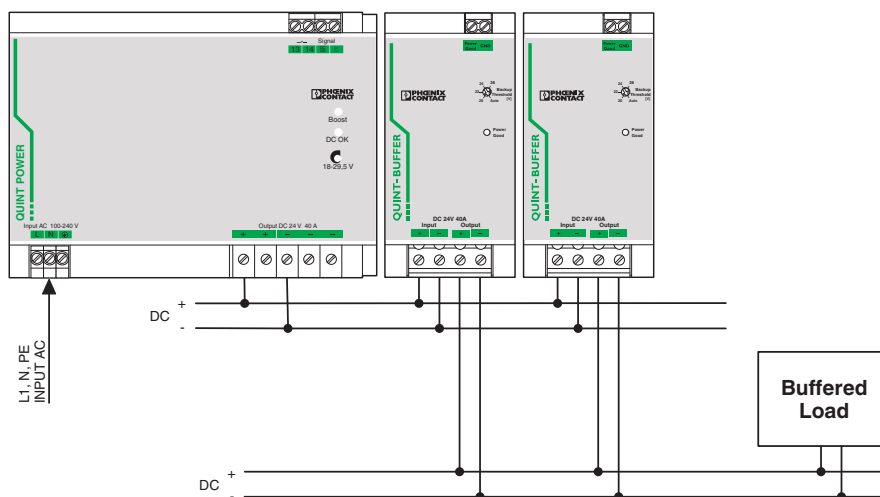



SCATTERGOOD & JOHNSON LTD

ELECTRICAL ENGINEERING & FLUID CONTROL DISTRIBUTORS

Est.1899

At Scattergood & Johnson Ltd, we pride ourselves on being a technical distributor to specialist industries.

Working with a range of quality product suppliers across a number of specialist markets, we are not your average 'box shifter' - we are your technical and supply chain partner.

We fully support every product we sell - for free! Our internal team and external sales engineers can answer any product or application question, no matter the complexity.

Backing up this technical ability is a range of 50,000+ products available from stock for nationwide next day delivery (same day if required!), or you can collect what you need from any of our trade counters around the UK.

Select your specialist interest below to learn more about how we can help.

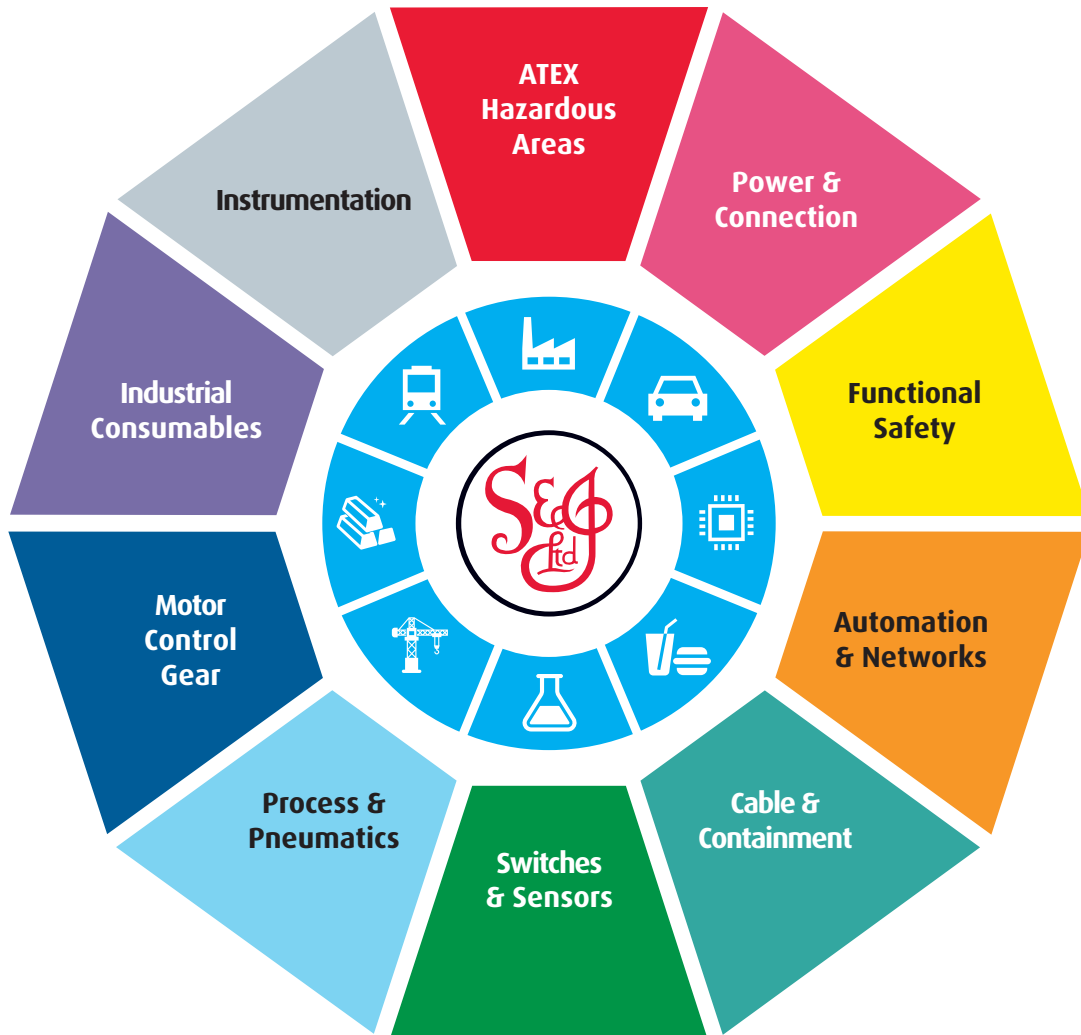

Online, In Branch and On the Road - Scattergood & Johnson Ltd, there when you need us.

www.scatts.co.uk