

DC/DC converter, protective coating - QUINT-PS/24DC/24DC/10/CO - 2320555

Please be informed that the data shown in this PDF Document is generated from our Online Catalog. Please find the complete data in the user's documentation. Our General Terms of Use for Downloads are valid (<http://phoenixcontact.com/download>)



Primary-switched QUINT DC/DC converter for DIN rail mounting with SFB (Selective Fuse Breaking) Technology, with protective coating, input: 24 V DC, output: 24 V DC/10 A

Product Description

QUINT DC/DC converter with maximum functionality

DC/DC converters alter the voltage level, regenerate the voltage at the end of long cables or enable the creation of independent supply systems by means of electrical isolation.

QUINT DC/DC converters magnetically and therefore quickly trip circuit breakers with six times the nominal current, for selective and therefore cost-effective system protection. The high level of system availability is additionally ensured, thanks to preventive function monitoring, as it reports critical operating states before errors occur.

Your advantages

- ✓ Reliable starting of difficult loads, thanks to the static POWER BOOST power reserve with up to 125% nominal current permanently
- ✓ Preventive function monitoring indicates critical operating states before errors occur
- ✓ Constant voltage: output voltage regenerated even at the end of long cables
- ✓ Support conversion to various voltage levels
- ✓ Electrical isolation: for setting up independent supply systems
- ✓ Optimum protection with dip coating for 100 % humidity



Key Commercial Data

Packing unit	1 pc
GTIN	 4 046356 693646
GTIN	4046356693646
Weight per Piece (excluding packing)	900.000 g
Custom tariff number	85044030
Country of origin	China

Technical data

Dimensions

Width	48 mm
-------	-------

DC/DC converter, protective coating - QUINT-PS/24DC/24DC/10/ CO - 2320555

Technical data

Dimensions

Height	130 mm
Depth	125 mm
Width with alternative assembly	122 mm
Height with alternative assembly	130 mm
Depth with alternative assembly	51 mm

Ambient conditions

Degree of protection	IP20
Ambient temperature (operation)	-25 °C ... 70 °C (> 60 °C derating, 2.5 %/K, startup at -40 °C type-tested)
Ambient temperature (start-up type tested)	-40 °C
Ambient temperature (storage/transport)	-40 °C ... 85 °C
Max. permissible relative humidity (operation)	100 % (at 25 °C, non-condensing)
Climatic class	3K3 (in acc. with EN 60721)
Degree of pollution	2

Input data

Nominal input voltage range	24 V DC
Input voltage range	18 V DC ... 32 V DC
Extended input voltage range in operation	14 V DC ... 18 V DC (Derating)
Current consumption	14 A (24 V, I _{BOOST})
Inrush current	typ. 15 A
Mains buffering time	typ. 12 ms (24 V DC)
Input fuse	25 A (device protection)
Recommended breaker for input protection	16 A ... 20 A (Characteristics B, C, D, K)
Type of protection	Transient surge protection
Protective circuit/component	Varistor

Output data

Nominal output voltage	24 V DC ±1 %
Setting range of the output voltage (U _{Set})	18 V DC ... 29.5 V DC (> 24 V DC, constant capacity restricted)
Nominal output current (I _N)	10 A (-25 °C ... 60 °C)
POWER BOOST (I _{Boost})	12.5 A (-25 °C ... 40 °C permanent, U _{OUT} = 24 V DC)
Selective Fuse Breaking (I _{SFB})	60 A (12 ms)
Derating	60 °C ... 70 °C (2.5%/K)
Connection in parallel	Yes, for redundancy and increased capacity
Connection in series	yes
Feedback voltage resistance	35 V DC
Protection against overvoltage at the output (OVP)	< 35 V DC
Max. capacitive load	unlimited
Active current limitation	Approx. 18 A
Control deviation	< 1 % (change in load, static 10 % ... 90 %)

DC/DC converter, protective coating - QUINT-PS/24DC/24DC/10/ CO - 2320555

Technical data

Output data

	< 2 % (change in load, dynamic 10 % ... 90 %)
	< 0.1 % (change in input voltage ± 10 %)
Residual ripple	< 20 mV _{PP}
Peak switching voltages nominal load	< 10 mV _{PP} (20 MHz)
Maximum power dissipation in no-load condition	1.6 W
Power loss nominal load max.	24 W

General

Net weight	0.9 kg
Efficiency	> 92 %
Insulation voltage input/output	1.5 kV (type test)
	1 kV (routine test)
Protection class	III
Degree of protection	IP20
	> 763000 h (40 °C)
Mounting position	horizontal DIN rail NS 35, EN 60715
Assembly instructions	alignable: $P_N \geq 50\%$, 5 mm horizontally, 15 mm next to active components, 50 mm vertically alignable: $P_N < 50\%$, 0 mm horizontally, 40 mm vertically top, 20 mm vertically bottom

Connection data, input

Connection method	Pluggable screw connection
Conductor cross section solid min.	0.2 mm ²
Conductor cross section solid max.	2.5 mm ²
Conductor cross section flexible min.	0.2 mm ²
Conductor cross section flexible max.	2.5 mm ²
Conductor cross section AWG min.	24
Conductor cross section AWG max.	12
Stripping length	8 mm
Screw thread	M3

Connection data, output

Connection method	Pluggable screw connection
Conductor cross section solid min.	0.2 mm ²
Conductor cross section solid max.	2.5 mm ²
Conductor cross section flexible min.	0.2 mm ²
Conductor cross section flexible max.	2.5 mm ²
Conductor cross section AWG min.	24
Conductor cross section AWG max.	12
Stripping length	7 mm
Screw thread	M3

DC/DC converter, protective coating - QUINT-PS/24DC/24DC/10/ CO - 2320555

Technical data

Connection data for signaling

Conductor cross section solid min.	0.2 mm ²
Conductor cross section solid max.	2.5 mm ²
Conductor cross section flexible min.	0.2 mm ²
Conductor cross section flexible max.	2.5 mm ²
Conductor cross section AWG min.	24
Conductor cross section AWG max.	12
Screw thread	M3

Standards

EMC requirements for noise immunity	EN 61000-6-1
	EN 61000-6-2
EMC requirements for noise emission	EN 61000-6-3
	EN 61000-6-4
Standard - Electrical safety	EN 60950-1/VDE 0805 (SELV)
Standard – Electronic equipment for use in electrical power installations and their assembly into electrical power installations	EN 50178/VDE 0160 (PELV)
Standard – Safety extra-low voltage	EN 60950-1 (SELV)
	EN 60204 (PELV)
Standard - Safe isolation	DIN VDE 0100-410
Rail applications	EN 50121-4
	EN 50155

Conformance/approvals

UL approvals	UL/C-UL listed UL 508
	UL/C-UL Recognized UL 60950-1
	UL ANSI/ISA-12.12.01 Class I, Division 2, Groups A, B, C, D (Hazardous Location)
Shipbuilding approval	DNV GL (EMC B)

EMC data

Electromagnetic compatibility	Conformance with EMC Directive 2014/30/EU
Electrostatic discharge	EN 61000-4-2
Contact discharge	8 kV (Test Level 4)
Discharge in air	15 kV (Test Level 4)
Electromagnetic HF field	EN 61000-4-3
Frequency range	80 MHz ... 1 GHz
Test field strength	10 V/m
Frequency range	1 GHz ... 2 GHz
Test field strength	10 V/m
Frequency range	2 GHz ... 3 GHz
Test field strength	10 V/m
Comments	Criterion A

<https://www.phoenixcontact.com/gb/products/2320555>



DC/DC converter, protective coating - QUINT-PS/24DC/24DC/10/ CO - 2320555

Technical data

EMC data

Fast transients (burst)	EN 61000-4-4
Input	2 kV (Test Level 3 - asymmetrical)
Output	2 kV (Test Level 3 - asymmetrical)
Signal	2 kV (Test Level 4 - asymmetrical)
Comments	Criterion A
Surge voltage load (surge)	EN 61000-4-5
Input	1 kV (Test Level 2 - symmetrical)
	2 kV (Test Level 3 - asymmetrical)
Output	1 kV (Test Level 2 - symmetrical)
	2 kV (Test Level 3 - asymmetrical)
Signal	1 kV (Test Level 2 - asymmetrical)
Comments	Criterion A
I/O/S	asymmetrical
Frequency range	0.15 MHz ... 80 MHz
Voltage	10 V (Test Level 3)
Comments	Criterion A
Criterion A	Normal operating behavior within the specified limits.
Criterion B	Temporary impairment to operational behavior that is corrected by the device itself.

Environmental Product Compliance

REACH SVHC	Lead 7439-92-1
China RoHS	Environmentally Friendly Use Period = 25;
	For details about hazardous substances go to tab "Downloads", Category "Manufacturer's declaration"

Drawings

DC/DC converter, protective coating - QUINT-PS/24DC/24DC/10/CO - 2320555

Block diagram

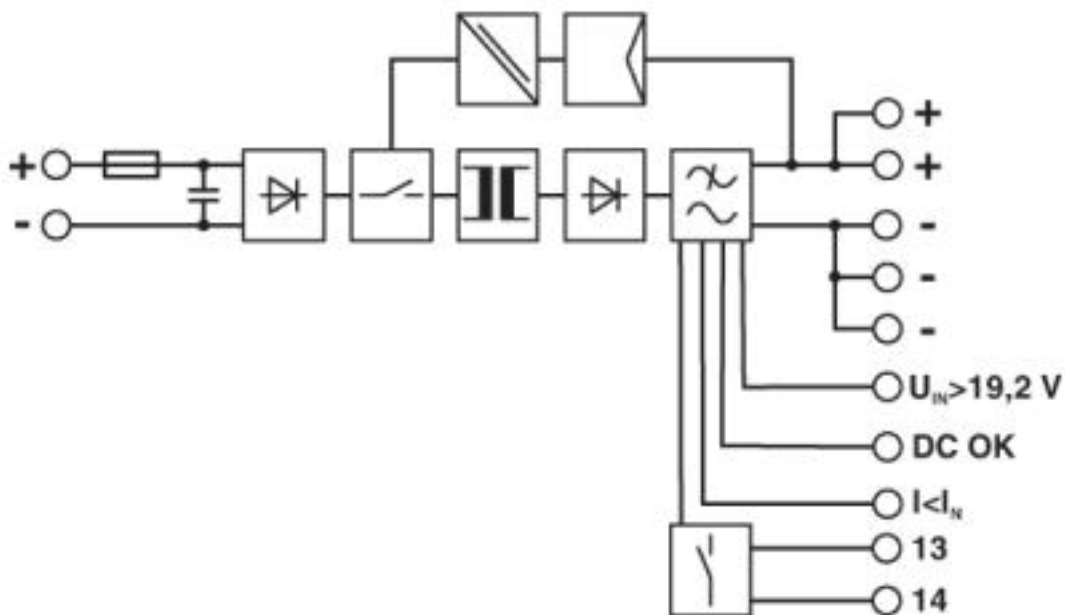

Classifications

eCl@ss

eCl@ss 4.0	27210900
eCl@ss 4.1	27210900
eCl@ss 5.0	27210900
eCl@ss 5.1	27210900
eCl@ss 6.0	27210900
eCl@ss 7.0	27210901
eCl@ss 8.0	27210901
eCl@ss 9.0	27210901

ETIM

ETIM 3.0	EC001039
ETIM 4.0	EC002540
ETIM 5.0	EC002046
ETIM 6.0	EC002046
ETIM 7.0	EC002046

UNSPSC

UNSPSC 6.01	30211502
UNSPSC 7.0901	39121004
UNSPSC 11	39121004
UNSPSC 12.01	39121004



DC/DC converter, protective coating - QUINT-PS/24DC/24DC/10/CO - 2320555

Classifications

UNSPSC

UNSPSC 13.2	39121041
-------------	----------

Approvals

Approvals

Approvals

BV / LR / NK / ABS / RINA / UL Listed / UL Recognized / cUL Recognized / cUL Listed / EAC / EAC / DNV GL / cULus Recognized / cULus Listed

Ex Approvals

IECEX / ATEX / UL Listed / cUL Listed / cULus Listed

Approval details

BV		http://www.veristar.com/portal/veristarinfo/generalinfo/approved/approvedProducts/equipmentAndMaterials	27662/B0 BV
----	---	---	-------------

LR		http://www.lr.org/en	12/20030
----	---	---	----------

NK		http://www.classnk.or.jp/hp/en/	12A013
----	---	---	--------

ABS		http://www.eagle.org/eagleExternalPortalWEB/	15-GD1363806-PDA
-----	--	---	------------------

RINA		http://www.rina.org/en	ELE112814XG
------	---	---	-------------

UL Listed		http://database.ul.com/cgi-bin/XYV/template/LISEXT/1FRAME/index.htm	FILE E 123528
-----------	---	---	---------------

UL Recognized		http://database.ul.com/cgi-bin/XYV/template/LISEXT/1FRAME/index.htm	FILE E 211944
---------------	---	---	---------------

DC/DC converter, protective coating - QUINT-PS/24DC/24DC/10/ CO - 2320555

Approvals

cUL Recognized		http://database.ul.com/cgi-bin/XYV/template/LISEXT/1FRAME/index.htm	FILE E 211944
----------------	--	---	---------------

cUL Listed		http://database.ul.com/cgi-bin/XYV/template/LISEXT/1FRAME/index.htm	FILE E 123528
------------	--	---	---------------

EAC		EAC-Zulassung
-----	--	---------------

EAC		RU C- DE.A*30.B.01082
-----	--	--------------------------

DNV GL		https://approvalfinder.dnvgl.com/	TAA000010E
Nominal voltage UN	750 V		
Nominal current IN	15 A		
mm ² /AWG/kcmil	4		

cULus Recognized	
------------------	--

cULus Listed	
--------------	--



SCATTERGOOD & JOHNSON LTD

ELECTRICAL ENGINEERING & FLUID CONTROL DISTRIBUTORS

Est.1899

At Scattergood & Johnson Ltd, we pride ourselves on being a technical distributor to specialist industries.

Working with a range of quality product suppliers across a number of specialist markets, we are not your average 'box shifter' - we are your technical and supply chain partner.

We fully support every product we sell - for free! Our internal team and external sales engineers can answer any product or application question, no matter the complexity.

Backing up this technical ability is a range of 50,000+ products available from stock for nationwide next day delivery (same day if required!), or you can collect what you need from any of our trade counters around the UK.

Select your specialist interest below to learn more about how we can help.



Online, In Branch and On the Road - Scattergood & Johnson Ltd, there when you need us.

www.scatts.co.uk