

Power Supply Unit, Primary Switched, Narrow Design MINI-PS-48-60DC/24DC/1

- **Extra narrow** design with widths of 22.5 mm, 45 mm, and 67.5 mm (0.886, 1.772, and 2.657 in.)
- **Global use** due to a wide-range input
- **A high level of operational safety** in complex global networks
- **Reliable startup** of heavy loads due to POWER BOOST

The reliability of a power supply unit determines the availability of individual components in a system and whether complex systems can function safely.

The globalization of markets increases the demands placed on the power supply unit. A wide-range input and a high level of availability are required. These requirements are met by MINI POWER.



1. Short Description

MINI POWER is the extra narrow power supply unit, which is available in widths of 22.5 mm, 45 mm, and 67.5 mm (0.886, 1.772, and 2.657 in.).

In addition to a 24 V version with output currents of 1 A, 2 A, and 4 A, special voltages are also available with 5 V/3 A, +/-15 V/1 A, and 10 - 15 V/2 A for connection to single-phase AC networks or to two external conductors in three-phase networks with nominal voltages of 100 - 240 V AC. Two DC/DC converters convert low direct voltages into an adjustable and regulated 24 V output voltage.

With the DIN rail bus connector, the MINI-SYS-PS can be connected in parallel to supply other modules in the same system with a regulated 24 V DC voltage.

Reliable startup of heavy loads is ensured by a power reserve of up to 100% – the POWER BOOST.

The high level of operational safety is also ensured in complex global networks. MINI POWER also operates in applications where static voltage dips, transient power supply failures or phase failure are common.

Powerful capacitors ensure mains buffering of more than 20 ms at full load.

2. Area of Application

MINI POWER can be used globally due to the consistent provision of a wide-range input.

In this way, your entire system can be tested at any production location in the world and can be delivered to any location in the world without faulty switching of the input voltage. This reduces storage costs and logistical effort.

An international approval package including UL 60950 for IT equipment and UL 508 for industrial control equipment enables the device to be used globally.

Headquarters: © Phoenix Contact GmbH & Co. KG • Flachsmarktstraße 8 • 32825 Blomberg • Germany

Phone +49 - 52 35 - 30 0 • Fax +49 - 52 35 - 34 12 00 • www.phoenixcontact.com

Local Contact: www.phoenixcontact.com/salesnetwork

Power Supply Unit, Primary Switched, Narrow Design – MINI-PS-48-60DC/24DC/1

3. Technical Data

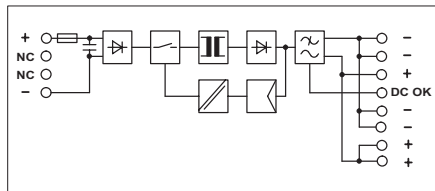

MINI-PS-48-60DC/24DC/1

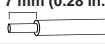
7 mm (0.28 in.)	Solid	Stranded	Torque		
	[mm ²]	AWG	[Nm]	[lb in]	
Input	0.2 - 2.5	0.2 - 2.5 25 - 14	0.5 - 0.6	4.4 - 5.3	
Output	0.2 - 2.5	0.2 - 2.5 25 - 14	0.5 - 0.6	4.4 - 5.3	
Signal	0.2 - 2.5	0.2 - 2.5 24 - 14	0.5 - 0.6	4.4 - 5.3	

DC/DC Converter



Description
Power supply, primary switched, narrow design

Type	Order No.	Pcs. Pkt.
MINI-PS-48-60DC/24DC/1	28 66 27 1	1

Technical Data

Input Data ①

Nominal input voltage
 Input voltage range (current consumption)
 Current consumption (for nominal values)
 Inrush current limiting
 Mains buffering for a nominal load (typical)
 Switch-on time after applying the mains voltage
 Transient surge protection
 Input fuse, internal

48 - 60 V DC (wide-range input)
 36 - 75 V DC
 0.6 (at 48 V DC), 0.5 (at 60 V DC)
 < 15 A, typical
 15 ms (at 48 V DC), 20 ms (device protection) (at 60 V DC)
 < 0.5 s
 Varistor
 T 3.15 AL 250 V (3.15 A)

Output Data ②

Nominal output voltage U_N /tolerance
 Setting range for the output voltage
 Output current during convection cooling and nominal values
 POWER BOOST I_{BOOST} (typical $t < 2$ min., -25°C to 60°C [-13°F to +140°F])
 Nominal output current I_N -25°C to +60°C (-13°F to +140°F)

24 V DC/±1%
 22.5 - 28.5 V DC

1.5 A ($U_{OUT} = 24$ V)
 1 A ($U_{OUT} = 24$ V)

Derating
 Short-circuit current limit
 Startup of capacitive loads
 System deviation on:

Static load change 10 - 90%
 Dynamic load change 10 - 90%
 Input voltage change ±10%
 No load/nominal load

From +60°C (+140°F), 2.5% per Kelvin
 6 A
 Unlimited

Maximum power dissipation
 Level of efficiency (typical)
 Response time U_{OUT} (10% - 90%)
 Residual ripple/switching peaks (20 MHz)
 Can be connected in parallel
 Internal surge protection
 Resistance to return supply



< 1%, typical
 < 3%, typical
 < 0.1%, typical
 1.2 W/5 W
 > 85% (at 60 V DC and at nominal values)
 < 30 ms, typical
 < 100 mV_{pp} (for nominal values)
 To increase redundancy and power
 Yes, limited to 35 V DC, approximately
 35 V DC

Signal Output Data

DC OK (active) ($U_{out} > 21.5$ V DC ≙ high signal)
 LED ($U_{out} > 21.5$ V DC ≙ LED permanently on)

+24 V signal/20 mA, maximum
 Green LED

Power Supply Unit, Primary Switched, Narrow Design – MINI-PS-48-60DC/24DC/1

General Data	
Insulation voltage:	Input/output 1.5 kV AC (type test)/1 kV AC (routine test)
Approval package	EN 60 204 (Surge Voltage Category III) EN 61 558-2-17 EN 60950/VDE 0805 UL/C-UL Recognized UL 60 950  UL/C-UL Listed UL 508  LISTED
Electrical equipment of machines	
Safety transformers for switched-mode power supply units	
Electrical safety (of IT equipment)	
Industrial control equipment	
Electronic equipment for use in electrical power installations	EN 50 178/VDE 0160 PELV (EN 60 204) SELV (EN 60 950) VDE 0100-410
Safety extra-low voltage	
Safe isolation	DIN VDE 0106-101 According to EN 61000-3-2
Protection against electric shock, basic requirements for safe isolation in electrical equipment	
Limitation of harmonic line currents	
Mounting position	On horizontal NS 35 DIN rail according to EN 60715
Can be mounted with spacing	With spacing of ≥ 5 cm (1.969 in.) 0 cm (0 in.)
Degree of protection	IP20
Class of protection	II, (in closed control cabinets)
MTBF	> 500,000 h according to IEC 1709 (SN 29 500)
Housing version	Polyamide PA, color green
Weight	0.2 kg, approximately
Dimensions (W x H x D)	22.5 x 99 x 114.5 mm (0.886 x 9.898 x 4.508 in.)
Climatic Data	
Ambient temperature	Operation: -25°C to +70°C [-13°F to +158°F] (> +60°C [140°F] derating) Storage: -40°C to +85°C [-40°F to +185°F]
Humidity	Up to 95% at +25°C [77°F], no condensation
Vibration	< 15 Hz, amplitude ±2.5 mm/15 Hz - 150 Hz, 2.3 g
Shock	30 g all space directions
Pollution degree	2 (according to EN 50 178)
Climatic category	3K3 (according to EN 60 721)



Conformance With EMC Directive 89/336/EEC and Low Voltage Directive 73/23/EEC

EMC (Electromagnetic Compatibility) Noise Immunity According to EN 61000-6-2:

Test	Standard	Notes
Electrostatic discharge (ESD)	EN 61000-4-2 ³⁾	Housing Contact discharge: Air discharge:
Electromagnetic HF field	EN 61000-4-3 ²⁾	Housing Frequency: Field strength:
Fast transients (burst)	EN 61000-4-4 ³⁾	Input: Output: Signal:
Surge current loads (surge)	EN 61000-4-5 ³⁾	
Conducted interference	EN 61000-4-6 ²⁾	I/O/S: Frequency: U ₀ :
Voltage dips	EN 61000-4-11 ³⁾	Input:

Requirements EN 61 000-6-2 MINI-PS-48-60DC/24DC/1

Requirements EN 61 000-6-2	MINI-PS-48-60DC/24DC/1
4 kV 8 kV	> Level 3 8 kV 8 kV
80 - 1000 MHz 10 V/m	Level 3 80 - 2000 MHz 10 V/m
2 kV asymmetrical ⁵⁾ 2 kV asymmetrical ⁵⁾ 1 kV asymmetrical ⁵⁾	2 kV (Level 3) 2 kV (Level 3) 1 kV (Level 2)
2 kV asymmetrical ⁵⁾ 1 kV symmetrical ⁴⁾	4 kV (Level 3) 2 kV (Level 3)
0.15 - 80 MHz 10 V	Level 3 0.15 - 80 MHz 10 V
30% reduction of the input voltage for 0.5 periods	See Input Data: Mains buffering > 20 ms

Noise Emission According to EN 50081-2:

Radio interference voltage	EN 55011
Radio interference emission	EN 55011
EN 55011 corresponds to CISPR11/EN 55022 corresponds to CISPR22	
EN 61000 corresponds to IEC 1000	

Class A ⁶⁾	EN 55011 (EN 55022) Class B ⁷⁾
Class A ⁶⁾	EN 55011 (EN 55022) Class B ⁷⁾

2) Criterion A: Normal operating characteristics within the specified limits.
3) Criterion B: Temporary adverse effects on the operating characteristics, which the device corrects automatically.

4) symmetrical: Cable to cable
5) asymmetrical: Cable to ground
6) Class A: Industrial applications
7) Class B: Industrial and domestic applications

Power Supply Unit, Primary Switched, Narrow Design – MINI-PS-48-60DC/24DC/1

4. Device View, Connections, and Control Elements

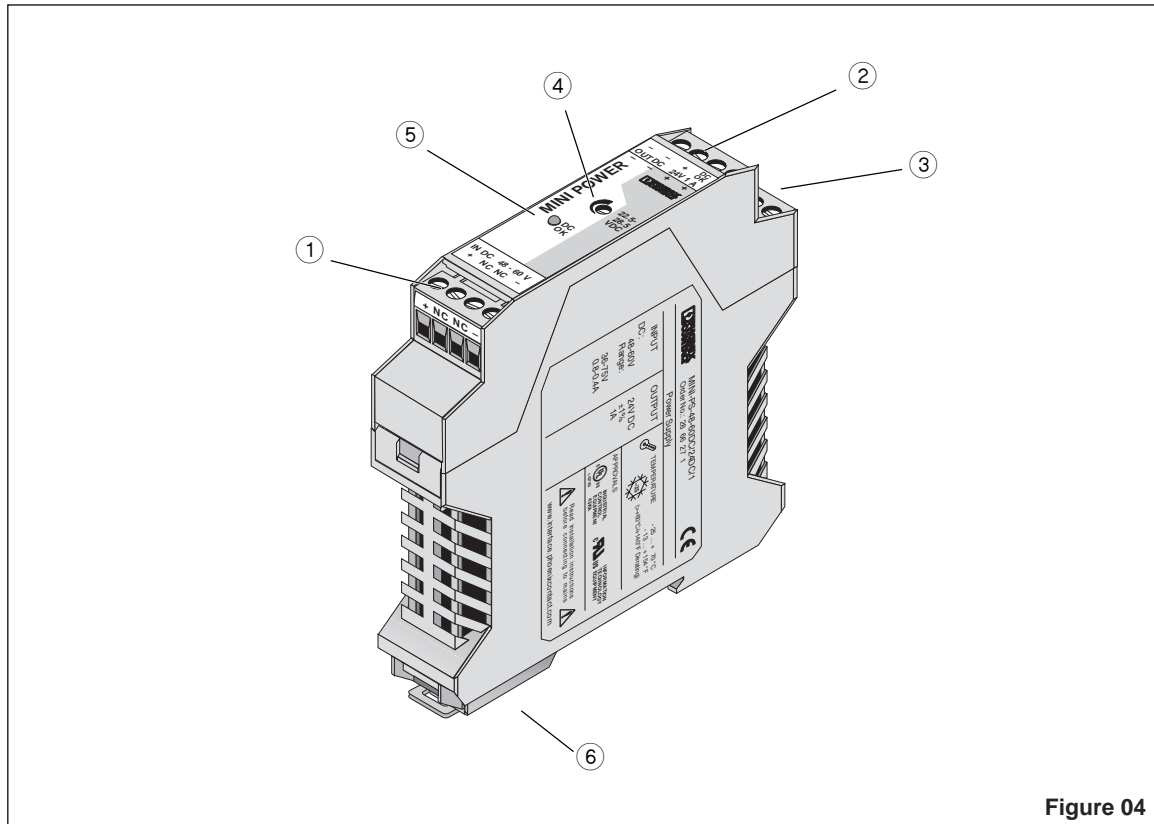

Figure 04

- ① **DC input:**
36 - 75 V DC input voltage
(0.2 mm² to 2.5 mm² solid)
(0.2 mm² to 2.5 mm² stranded) (25 - 14 AWG)
Internal fuse 3.15 A
- ② **DC output:**
24 V DC output voltage (default),
can be set from 22.5 - 28.5 V DC using
potentiometer ④ (0.2 mm² to 2.5 mm² solid)
(0.2 mm² to 2.5 mm² stranded) (25 - 14 AWG)
The device is idling-proof and short-circuit-proof.
- ③ **DC OK output active**
- ④ **Potentiometer 22.5 - 28.5 V DC**
- ⑤ **DC OK LED**
- ⑥ **Universal latching foot for EN DIN rails**

5. Safety Notes and Warning Instructions

To ensure that the device can be operated safely and all functions can be used, please read these instructions carefully.

Installation and startup must only be carried out by qualified personnel. The relevant country-specific regulations (e.g., VDE, DIN) must also be observed.

Before startup it is particularly important to ensure that:

- All supply lines have sufficient fuse protection and are the correct size.
- All output cables are the correct size for the maximum device output current or have separate fuse protection.
- Sufficient convection is ensured.

Power Supply Unit, Primary Switched, Narrow Design – MINI-PS-48-60DC/24DC/1

6. Installation

6.1. Mounting

The power supply unit can be snapped onto all DIN rails according to EN 60715. The device must be mounted horizontally (input terminal blocks facing downwards).

Installation Dimensions

 To ensure sufficient convection, a minimum spacing of 5 cm (1.969 in.) to other modules is required above and below the device.

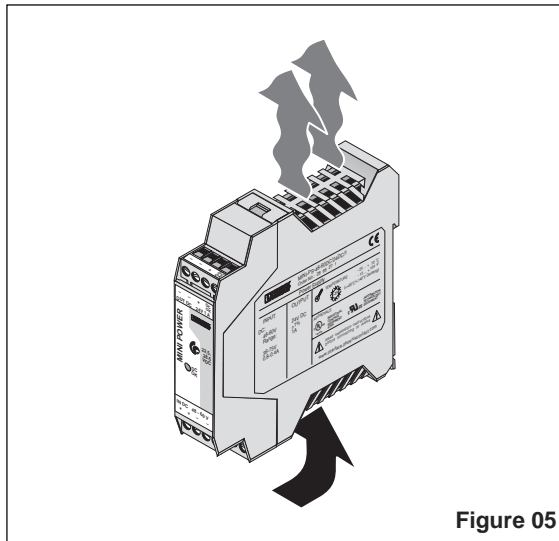

Figure 05

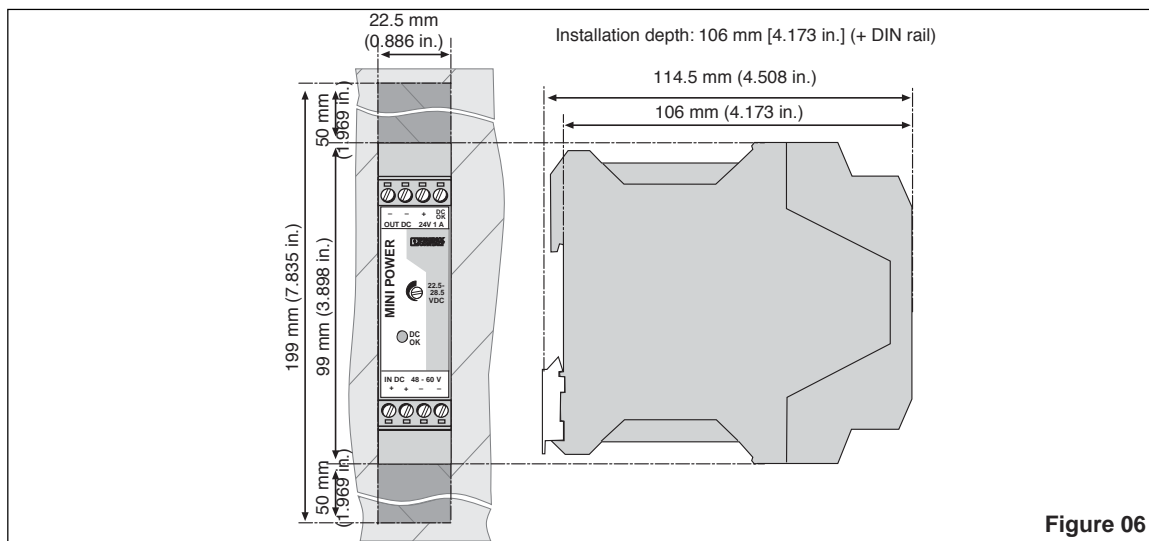

Figure 06

Mounting:

Place the module with the DIN rail guideway on the **top edge** of the DIN rail and then snap it **downwards**.

Removal:

Release the snap-on catch using a screwdriver and then detach the module from the **bottom edge** of the DIN rail.

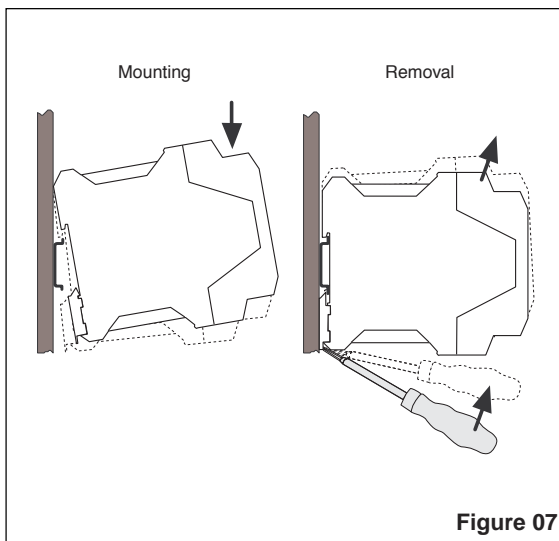

Figure 07

Power Supply Unit, Primary Switched, Narrow Design – MINI-PS-48-60DC/24DC/1

6.2 Connecting Cable

The device is equipped with COMBICON connectors. This reliable user-friendly connection method enables quick device connection and visible isolation of the electrical connection, if required.

Only operate connectors when the power is switched off.

The following cable cross sections can be connected:

	Solid [mm ²]	Stranded [mm ²]	AWG	Torque [Nm] [lb in]	
① Input:	0.2 - 2.5	0.2 - 2.5	25 - 14	0.5 - 0.6	4.4 - 5.3
② Output:	0.2 - 2.5	0.2 - 2.5	25 - 14	0.5 - 0.6	4.4 - 5.3
③ Signal:	0.2 - 2.5	0.2 - 2.5	25 - 14	0.5 - 0.6	4.4 - 5.3

7 mm (0.28 in.)



For reliable and safe-to-touch connections: Strip 7 mm (0.28 in.) from the connector ends.

6.3. Input (①, Figure 9)

The 48 - 60 V DC connection is made using the "+" and "-" screw connections.

Protecting the Primary Side

The device must be installed according to the specifications of EN 60 950.

Device protection is not required, as an internal fuse is present.



If the internal fuse is blown, this is most probably due to a device fault. In this case, the device should be checked in the factory.

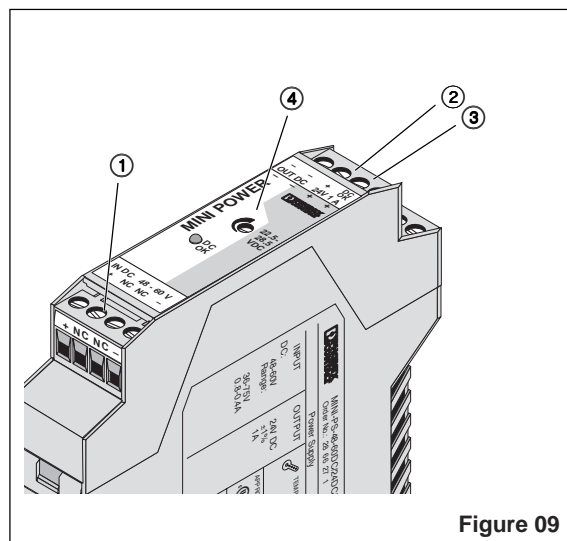

Figure 09

Power Supply Unit, Primary Switched, Narrow Design – MINI-PS-48-60DC/24DC/1

6.4. Output (②, Figure 9)

The 24 V DC connection is made using the "+" and "-" screw connections on the screw connection ②. The output voltage set upon delivery is 24 V DC.

The output voltage can be adjusted from 22.5 to 28.5 V DC on the potentiometer ④.

Protecting the Secondary Side:

The device is electronically short-circuit-proof and idling-proof. In the event of an error, the output voltage is limited to a maximum of 35 V DC.

It should be ensured that all output cables are the correct size for the maximum output current or have separate fuse protection.

The cable cross sections in the secondary circuit should be large enough to keep the voltage drops on the cables as low as possible.

Active Signal Output (③, Figure 10)

The 24 V DC signal is between the "DC OK" and "-" connection terminal blocks and can be loaded with 20 mA maximum. This signal output indicates that the output voltage has fallen below 21.5 V DC when "active high" changes to "low".

The DC OK signal is isolated from the power output. This ensures that a separate supply does not enter from devices connected in parallel.

The 24 V DC signal can be connected directly to a logic input for evaluation.

Signaling

The active DC OK switching output and the DC OK LED provide function monitoring.

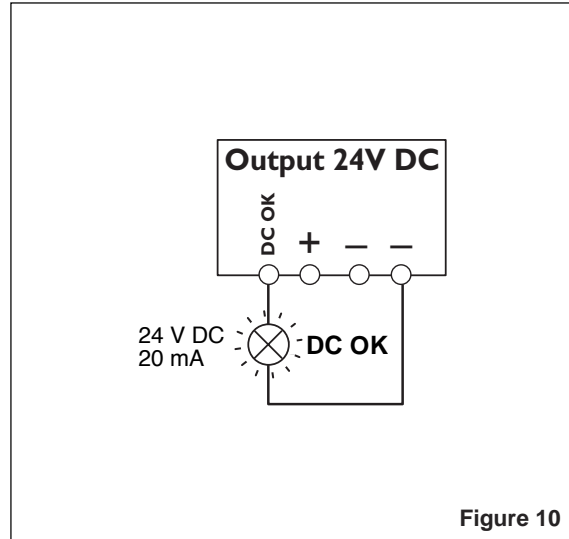

Figure 10

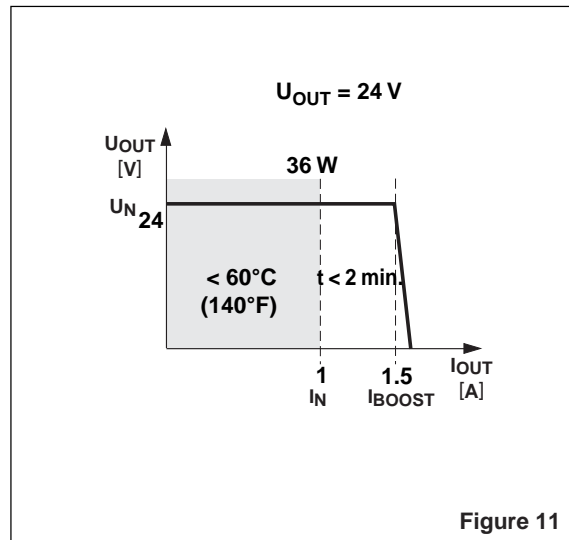

Figure 11

	Status 1	Status 2
Green "DC OK" LED ⑤	ON	OFF
Active DC OK switching output ③	U = +24 V (with reference to "-")	U = 0 V (with reference to "-")
Meaning	Normal operation of the power supply unit U _{OUT} > 21.5 V	U _{OUT} ≤ 21.5 V DC <ul style="list-style-type: none"> • Secondary load short circuit or overload • No mains voltage or device fault

7. Installation

7.1. Output Characteristic Curve

The device can supply a nominal output current of 1 A up to an ambient temperature of 60°C (140°F). At temperatures up to 60°C (140°F), the POWER BOOST provides a short-term output current of 1.5 A for a few minutes.

In the event of heavier loads the working point demonstrates the U/I characteristic curve shown in Figure 11.

On an overload or short circuit, the entire output current I_{BOOST} is provided permanently at a reduced output voltage.

Once the overload or short circuit has been removed, the entire set secondary voltage is available again.

The U/I characteristic curve ensures that both heavy capacitive loads and devices with DC/DC converters can be supplied by MINI POWER in the input circuit without any problems.

Connected fuses are reliably tripped. The selectivity in your system configuration is ensured at all times.

Power Supply Unit, Primary Switched, Narrow Design – MINI-PS-48-60DC/24DC/1

7.2. Temperature Response

The device can supply a nominal output current of 1 A up to an ambient temperature of 60°C (140°F). At temperatures up to 60°C (140°F), the POWER BOOST provides a short-term output current of 1.5 A for a few minutes.

The output power must be decreased by 2.5% per Kelvin temperature increase for ambient temperatures above +60°C (140°F). At ambient temperatures above +70°C (+158°F) or in the event of a thermal overload, the device reduces the output power to protect itself and returns to normal operation once it has cooled down.

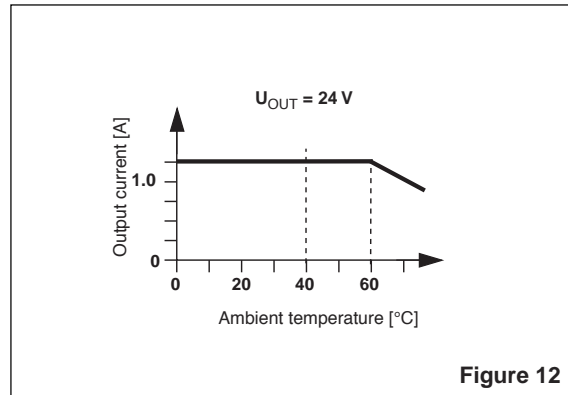

Figure 12

7.3. Parallel Operation

Devices of the same type can be connected in parallel to increase both redundancy and power. The default setting does not have to be adjusted.

If the output voltage is adjusted, an even current distribution can be ensured by precisely setting all power supply units that are operated in parallel to the same output voltage.

To ensure symmetrical current distribution we recommend that all cable connections from the power supply unit to the DIN rail are the same length and have the same cross section.

Depending on the system, for parallel connection of more than two power supply units a protective circuit should be installed at each individual device output (e.g., decoupling diode or DC fuse). This prevents high return currents in the event of a secondary device fault.

7.4. Redundancy Operation

Redundant connections are designed for supplying systems, which place particularly high requirements on operational safety. If a fault occurs in the primary circuit of the first power supply unit, the second device automatically takes over the complete power supply without interruption, and vice versa.

For this purpose, the power supply units to be connected in parallel must be large enough that the total current requirements of all loads can be fully met by one power supply unit. External decoupling diodes are required for 100% redundancy.

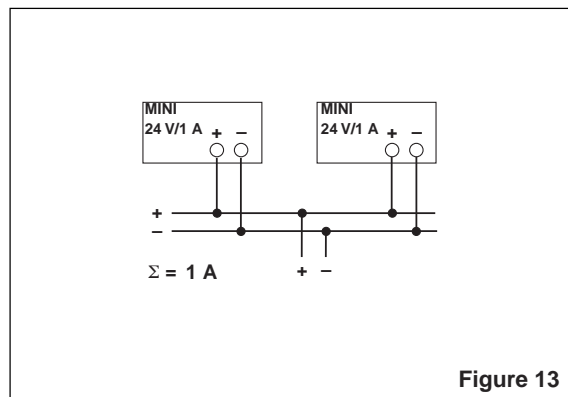

Figure 13

7.5. Increasing Power

The output current can be increased to $n \times I_N$ where n is the number of devices connected in parallel.

Parallel connection for increasing power is used when extending existing systems. A parallel connection is recommended if the power supply unit does not cover the current consumption of the most powerful load. Otherwise, the loads should be divided over independent individual devices.

A maximum of five devices can be connected in parallel.

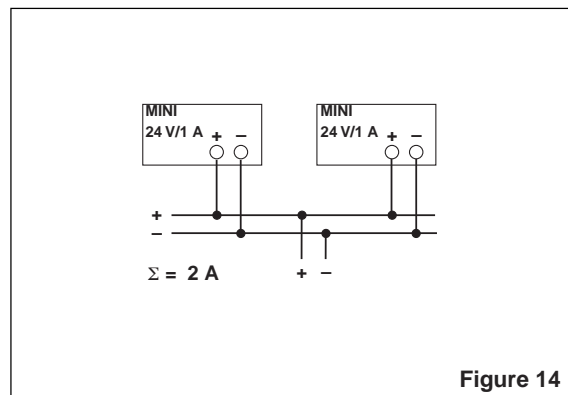

Figure 14



SCATTERGOOD & JOHNSON LTD

ELECTRICAL ENGINEERING & FLUID CONTROL DISTRIBUTORS

Est.1899

At Scattergood & Johnson Ltd, we pride ourselves on being a technical distributor to specialist industries.

Working with a range of quality product suppliers across a number of specialist markets, we are not your average 'box shifter' - we are your technical and supply chain partner.

We fully support every product we sell - for free! Our internal team and external sales engineers can answer any product or application question, no matter the complexity.

Backing up this technical ability is a range of 50,000+ products available from stock for nationwide next day delivery (same day if required!), or you can collect what you need from any of our trade counters around the UK.

Select your specialist interest below to learn more about how we can help.



Online, In Branch and On the Road - Scattergood & Johnson Ltd, there when you need us.

www.scatts.co.uk