

## QUINT-PS-24DC/24DC/10

QUINT DC-DC converter, primary switched mode,  
input: 24 V DC, output: 24 V DC/10 A



### INTERFACE

Data Sheet

© PHOENIX CONTACT - 02/2006

### Description

The QUINT DC-DC converter 24 V/10 A converts the DC voltage from 18 V ... 32 V to an adjustable, controlled and galvanically separated 24 V output voltage. If no regulated and stable 24 V DC voltage is available to supply a load, DC-DC converters ensure the adjustment of the 24 V load: A non-regulated DC voltage is converted to an adjustable output voltage of 22.5 V ... 28.5 V.

Due to electrical isolation, the DC voltage circuits are electrically isolated from each other in a safe way. With a design width of only 80 mm, the housing is extremely slim. The floating DC-OK output and an LED are available for signaling.



#### Danger!

**Components with dangerously high voltage and high stored energy are located in the device!  
Never carry out work on live parts!  
Depending on the ambient temperature and the load, the housing can become very hot!**



Make sure you always use the the latest documentation.  
It can be downloaded at [www.download.phoenixcontact.com](http://www.download.phoenixcontact.com).  
A conversion table is available on the Internet at  
[www.download.phoenixcontact.com/general/7000\\_en\\_00.pdf](http://www.download.phoenixcontact.com/general/7000_en_00.pdf).



This data sheet is valid for the following products listed on the following page:

## Order data

| Description  | Type                  | Order No. | Pcs./pkt. |
|--|-----------------------|-----------|-----------|
| QUINT DC-DC converter, primary switched mode, input: 24 V DC, output: 24 V DC/10 A | QUINT-PS-24DC/24DC/10 | 2866378   | 1         |

## Technical data

| Input data                                 |                                     |
|--|-------------------------------------|
| Nominal input voltage                      | 24 V DC                             |
| Input voltage range DC                     | 18 V DC ... 32 V DC                 |
| DC frequency range                         | 0 Hz                                |
| Current consumption                        | Approx. 11.4 A (at 24 V)            |
| Inrush current limitation/I <sup>2</sup> t | < 20 A (typical)                    |
| Power failure bypass                       | > 3 ms (for 24 V DC)                |
| Typical response time                      | < 1 s                               |
| Protective circuitry                       | Transient surge protection Varistor |
| Input fuse                                 | Internal, 25A T                     |

| Output data                                      |   |
|--|---|
| Nominal output voltage                           | 24 V ±1%  |
| Setting range of the output voltage              | 22.5 V DC ... 28.5 V DC   |
| Output current                                   | 10 A (-25 °C ... 60 °C)   |
| Derating   | From +60°C 2.5% per Kelvin  |
| Current limitation                               | Approx. 18 A  |
| Max. capacitive load                             | Unlimited   |
| Control deviation                                | < 1 % (change in load, static 10% ... 90%)<br>< 2 % (change in load, dynamic 10% ... 90%)<br>< 0.1 % (change in input voltage ±10%) |
| Power loss nominal load max.                     | 28 W  |
| Maximum power dissipation idling                 | 2 W   |
| Efficiency                                       | > 88 %  |
| Ascent time                                      | < 2 ms (U <sub>OUT</sub> (10% ... 90%))   |
| Residual ripple                                  | < 100 mV <sub>SS</sub>  |
| Peak switching voltages                          | < 100 mV <sub>SS</sub>  |
| Connection in parallel                           | Yes, for redundancy and increased capacity  |
| Surge protection against internal surge voltages | Yes, limited to approx. 35 V DC   |
| Resistance to reverse feed                       | 35 V DC   |

| Status indication |  |
|-------------------|--|
| Status display    | "DC OK" LED green                        |
|                   | U <sub>OUT</sub> > 21.5 V: LED lights up |

| Signal output      |  |
|--------------------|--|
| DC OK active       |  |
| Output description | U <sub>OUT</sub> > 21.5 V: High signal |
| Continuous current | Max. 40 mA                             |
| Output voltage     | + 24 V DC                              |

**Signal output**

|                           |   |
|---------------------------|---|
| DC OK floating            |   |
| Output description        | $U_{OUT} > 21.5 \text{ V}$ : Contact closed |
| Continuous current        | Max. 1 A                                    |
| Maximum switching voltage | Max. 30 V AC/DC                             |

**Ratings / standards**

|  |   |
|--|---|
| Electrical Equipment for Machinery   | EN 60204  |
| Safety transformers for power supply units   | EN 61558-2-17   |
| Electrical safety (of information technology equipment)  | EN 60950/VDE 0805 (SELV)<br>UL/C-UL recognized UL 60950 |
| Industrial control equipment   | UL/C-UL Listed UL 508                                   |
| Shipbuilding   | German Lloyd, ABS                                       |
| Electronic equipment for use in electrical power installations                                   | EN 50178/VDE 0160 (PELV)                                |
| SELV   | EN 60950 (SELV)<br>EN 60204 (PELV)                      |
| Safe isolation   | DIN VDE 0100-410  |
| Protection against electric shock, basic requirements for safe isolation in electrical equipment | DIN VDE 0106-101  |

**General data**

|                                  |   |
|----------------------------------|---|
| Insulation voltage input/output  | 1.5 kV AC (type test)<br>1 kV AC (routine test) |
| Installation position            | Horizontal DIN rail NS 35, EN 60715             |
| Degree of protection             | IP20  |
| Class of protection              | Class 3   |
| MTBF                             | > 500 000 h in acc. with IEC 61709 (SN 29500)   |
| Housing version                  | AluNox (AlMg1)                                  |
| Width                            | 80 mm   |
| Height                           | 130 mm  |
| Depth                            | 125 mm  |
| Width with alternative assembly  | 122 mm  |
| Height with alternative assembly | 130 mm  |
| Depth with alternative assembly  | 83 mm   |
| Weight                           | 0.95 kg   |

**Climatic data**

|   |   |
|---|---|
| Ambient temperature (operation)                 | -25 °C ... 70 °C (> 60°C derating)  |
| Ambient temperature (storage/transport)         | -40 °C ... 85 °C  |
| Max. permissible. relative humidity (operation) | 95 % (at 25°C, no condensation)   |
| Vibration (operation)                           | < 15 Hz, amplitude $\pm 2.5 \text{ mm}$ in acc. with IEC 60068-2-6<br>15 Hz ... 150 Hz, 2.3g, 90 min. |
| Shock   | 30g in all directions in acc. with IEC 60068-2-27   |
| Pollution degree in acc. with EN 50178          | 2   |
| Climatic class                                  | 3K3 (in acc. with EN 60721)   |

**Conformance with EMC directive 89/336/EEC****Immunity to interference in acc. with EN 61000-6-2**

Discharge of static electricity in acc. with EN 61000-4-2

|                   |             |
|-------------------|-------------|
| Housing           | Level 3     |
| Contact discharge | 8 kV        |
| Discharge in air  | 8 kV        |
| Comments          | Criterion B |

Electromagnetic HF field in acc. with EN 61000-4-3

|                 |                  |
|-----------------|------------------|
| Housing         | Level 3          |
| Frequency range | 80 MHz ... 2 GHz |
| Field intensity | 10 V/m           |
| Comments        | Criterion A      |

Fast transients (burst) in acc. with EN 61000-4-4

|        |                               |
|--------|-------------------------------|
| Input  | 2 kV (Level 3 - asymmetrical) |
| Output | 2 kV (Level 3 - asymmetrical) |
| Signal | 1 kV (Level 2 - asymmetrical) |

Surge voltage capacities (surge) in acc. with EN 61000-4-5

|                     |  |
|---------------------|--|
| Input/Output/Signal | 2 kV (Level 3 - asymmetrical)<br>1 kV (Level 3 - asymmetrical) |
| Comments            | Criterion B  |

Conducted disturbance in acc. with EN 61000-4-6

|                     |                        |
|---------------------|------------------------|
| Input/Output/Signal | Level 3 - asymmetrical |
| Frequency range     | 0.15 MHz ... 80 MHz    |
| Voltage             | 10 V                   |
| Comments            | Criterion A            |

**Emitted interference in acc. with EN 61000-6-3**

Radio interference voltage in acc. with EN 55011

EN 55011 (EN 55022) Class B, area of application: Industry and residential

Emitted radio interference in acc. with EN 55011

EN 55011 (EN 55022) Class B, area of application: Industry and residential

Note:

Criterion A: Normal operating behavior within the defined limits.

Criterion B: Temporary impairment to operational behavior that is corrected by the device itself

EN 55011 corresponds to CISPR11 / EN 55022 corresponds to CISPR22

EN 61000 corresponds to IEC 1000

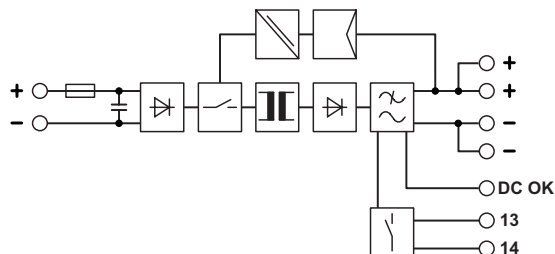
**Block diagram**

**Structure**

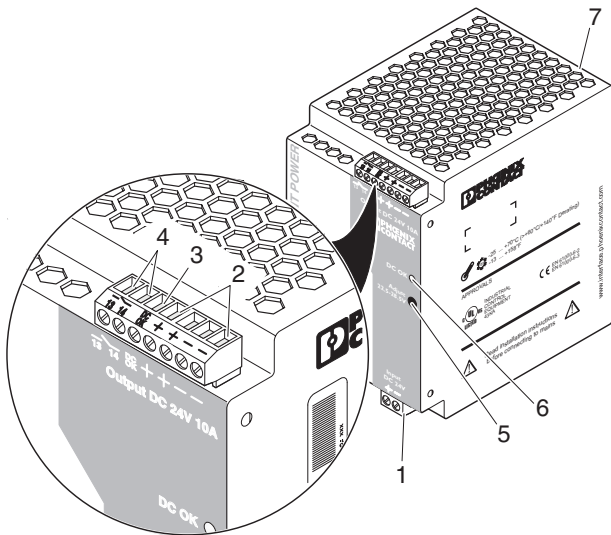

- 1 - DC input
- 2 - DC output
- 3 - DC OK output active
- 4 - DC OK output floating
- 5 - Potentiometer 22.5 V DC ... 28.5 V DC
- 6 - DC OK control lamp
- 7 - Universal DIN rail adapter UTA 107

|        | [mm <sup>2</sup> ] |           | AWG     | [Nm]<br>Torque |
|--------|--------------------|-----------|---------|----------------|
|        | solid              | stranded  |         |                |
| Input  | 0.2 - 2.5          | 0.2 - 2.5 | 24 - 12 | 0.5 - 0.6      |
| Output | 0.2 - 2.5          | 0.2 - 2.5 | 24 - 12 | 0.5 - 0.6      |
| signal | 0.2 - 2.5          | 0.2 - 2.5 | 24 - 12 | 0.5 - 0.6      |

**Input data**

|                        |                                |
|------------------------|--------------------------------|
| Nominal input voltage  | 24 V DC                        |
| Input voltage range DC | 18 V DC ... 32 V DC            |
| Input fuse             | internal, 25A T                |
| Type of connection     | COMBICON screw/plug connection |
| Stripping length       | 7 mm                           |

**Output data**

|                                     |                                |
|-------------------------------------|--------------------------------|
| Nominal output voltage              | 24 V ±1%                       |
| Setting range of the output voltage | 22.5 V DC ... 28.5 V DC        |
| Output current                      | 10 A (-25 °C ... 60 °C)        |
| Type of connection                  | COMBICON screw/plug connection |
| Stripping length                    | 7 mm                           |

## Safety and warning notes



The power supply units are built-in devices. The device may only be installed and put into operation by qualified personnel. The corresponding national regulations (e.g. VDE, DIN) must be observed.



### Danger!

**Components with dangerously high voltage and high stored energy are located in the device!  
Never carry out work on live parts!  
Depending on the ambient temperature and the load, the housing can become very hot!**



### Before startup please ensure:

**All feed lines are sufficiently protected and dimensioned!  
All output lines are dimensioned according to the maximum output current of the device or separately protected!  
Sufficient convection is guaranteed!**

## Installation

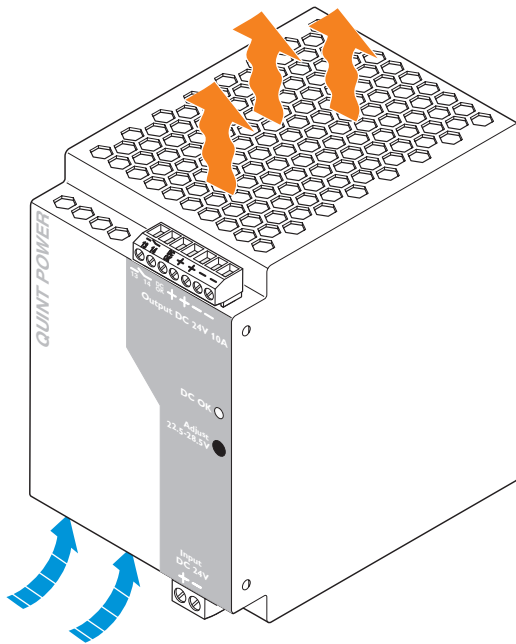

In order to guarantee sufficient convection, we recommend observing the following minimum distance to other modules: 5 cm in a vertical direction and 0 cm in a horizontal direction.



The power supply unit can be snapped onto all DIN rails in acc. with EN 60715. They must be horizontal (connecting terminal blocks below).

### Installation position

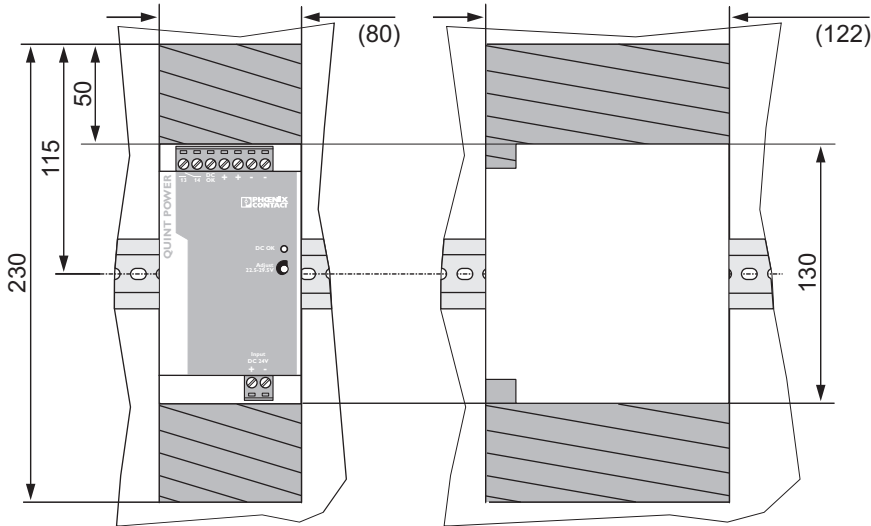

Slim-style installation: Installation depth 125 mm (+ DIN rail) (state at delivery)

Low-profile installation: Installation depth 83 mm (+ DIN rail)

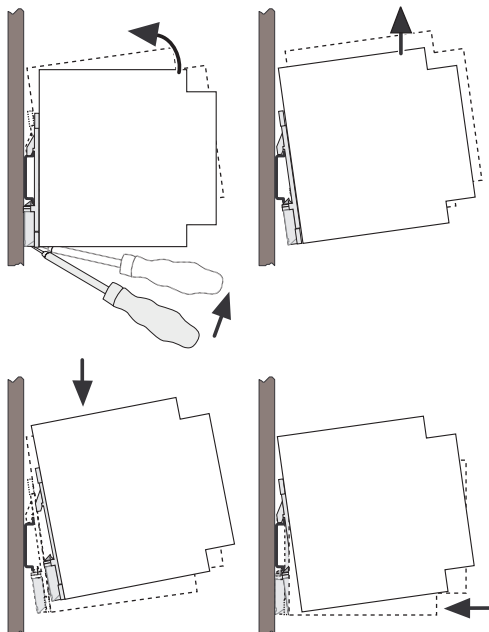

#### Slim-style installation:

##### Assembly

Position the module with the DIN rail guide on the upper edge of the DIN rail, and snap it in with a downward motion.

##### Dismantling

Pull the snap lever open with the aid of a screwdriver and slide the module out at the lower edge of the DIN rail.

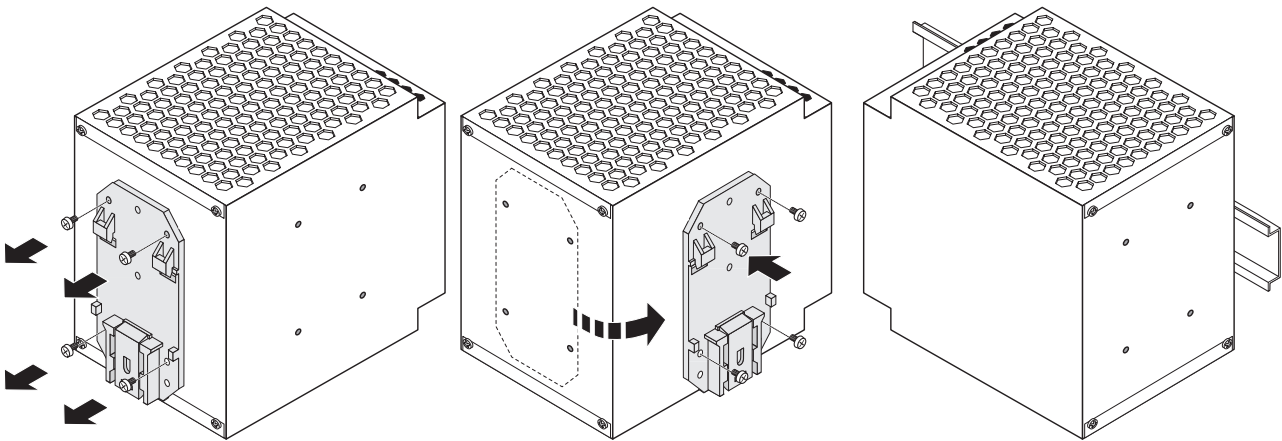

### Low-profile installation:

Low-profile installation can be achieved by mounting the device at right-angles to the DIN rail. Mount the DIN rail adapter (UTA 107) as described in the figure. No additional mounting material is required. Fixing screws: Torx T10 (torque 0.8 Nm ... 0.9 Nm).

### Input

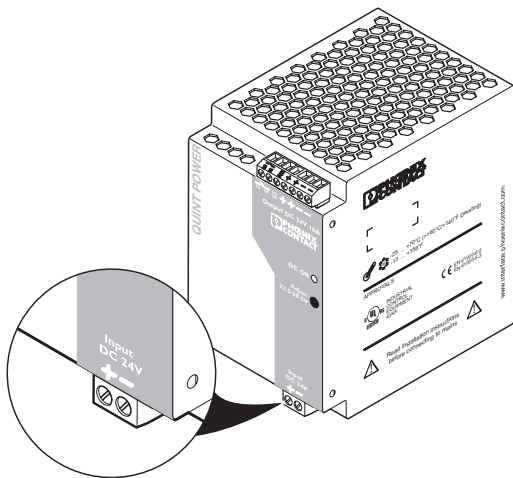

The connection is made using the "+" and "-" screw connections.

### Protection of the primary side

Device installation must be carried out according to the regulations in EN 60950.

For device protection, there is an internal fuse. Additional device protection is not necessary.



If an internal fuse is triggered, there is most probably a malfunction in the device. In this case, the device must be inspected in the factory!

## Output

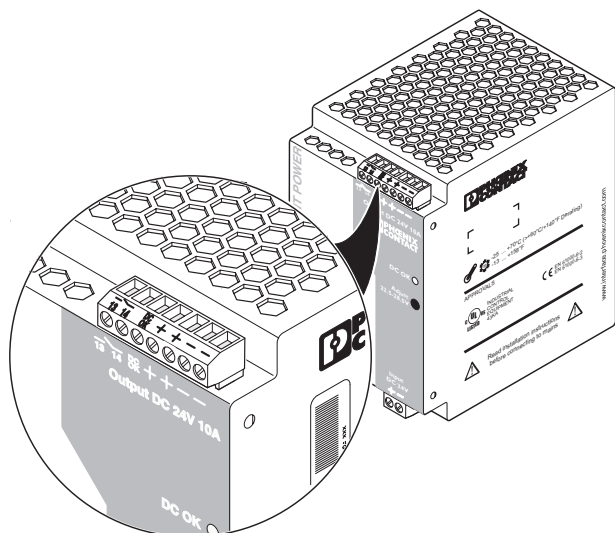

Make sure that all output lines are dimensioned according to the maximum output current or are separately protected! The cables on the secondary side must have large cross sections in order to keep the voltage drops on the lines as low as possible.

The connection is made using the "+" and "-" screw connections on the screw connection of the DC output. At the time of delivery, the output voltage is 24 V DC. The output voltage can be set on the potentiometer.

### Protection of the secondary side

The device is electronically protected against short circuit and idling. In the event of a malfunction, the output voltage is limited to 35 V DC.

### Signaling

The two DC OK outputs are for preventive monitoring of the functions of the power supply unit. A floating signal contact and an active DC OK signal are available. The DC OK LED also enables evaluation of the function of the power supply directly on site.

|                               | State 1   | State 2  |
|-------------------------------|---|--|
| DC OK LED                     | ON  | OFF  |
| Active DC OK switching output | U = +24 V (in reference to "-")                                     | U = 0 V (in reference to "-")  |
| Floating DC OK output         | Closed  | Open   |
| Meaning                       | Normal operation of the power supply ( $U_{OUT} > 21.5 \text{ V}$ ) | 1. The output voltage is less than 21.5 V.<br>There is a secondary consumer short circuit or overload.<br>2. There is no input voltage or there is a device fault. |

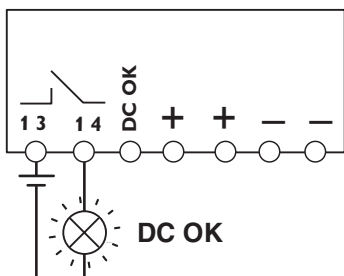

**Floating contact**

The floating signal contact opens and signalizes a drop in the output voltage of 21.5 V. Signals and ohmic loads of up to 30 V and currents of up to 1 A can be connected. For heavily inductive loads such as a relay, a suitable protection circuit (e.g. damping diode) is necessary.

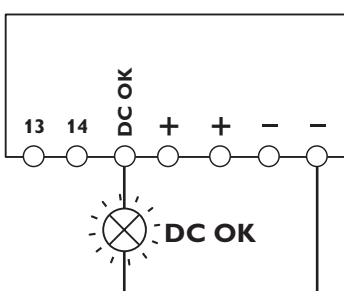

**Active signal output**

The 24 V DC signal is applied between the "DC OK" and "-" connecting terminal blocks and can carry up to 40 mA. When the output voltage drops below 21.5 V, this signal output signals by switching from "active high" to "low". The DC OK signal is decoupled from the power output. It is thus not possible for parallel switched devices to provide external supply. The 24 V DC signal can be directly connected to a logic input for evaluation.

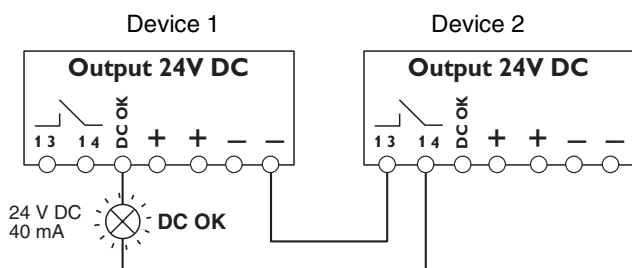

**Signal loop**

The two above-mentioned signal outputs can be easily combined.

Example: Monitoring of two devices. Use the active signal output of device 1 and loop in the floating signal output of device 2. In the event of malfunctioning, a common alarm is output. Any number of devices can be looped in. This signal combination saves wiring costs and logic inputs.

## Function

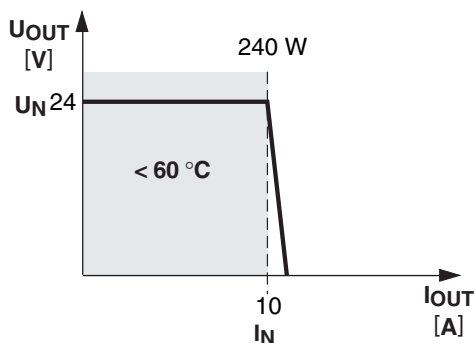

### Output characteristic curve

At environmental temperatures of  $T_{amb} < +60$  °C, the device can continuously supply 10 A at nominal voltage.

In the event of a higher load, the operating point follows the U/I characteristic curve depicted in the figure. The output current is limited to  $I_{BOOST}$ . Thereby, the device does not switch off, but rather supplies a continuous output current. The secondary voltage is reduced until the short circuit on the secondary side has been remedied.

The U/I characteristic curve ensures that both heavily capacitive loads and devices with DC/DC converters in the primary circuit can be fed without problems using QUINT POWER. Downstream fuses are triggered reliably. Selectivity in the design of your system is guaranteed at all times.

$$U_N = 24 \text{ V}$$

$$I_N = 10 \text{ A}$$

$$P_N = 240 \text{ W}$$

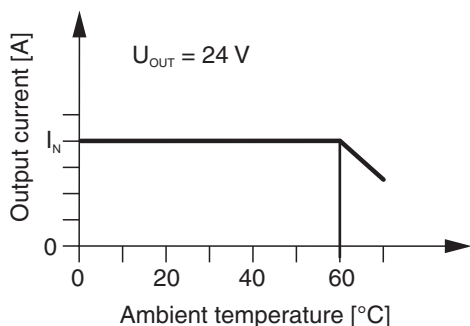

### Thermal behavior

With an ambient temperature of up to  $+60$  °C, the device supplies the continuous output current of  $I_N$ . In the case of ambient temperatures above  $+60$  °C, the output current must be reduced by 2.5% per Kelvin increase in temperature. The device does not switch off at ambient temperatures of  $+70$  °C or thermal overload. The output capacity is reduced as far as necessary to provide device protection. After it has cooled down, the output capacity is increased again.

### Parallel operation

Devices of the same type can be connected in parallel to enable both redundancy and an increase in efficiency. No other alignment is necessary when in the state of delivery.

If the output voltage is adjusted, a uniform distribution of power is guaranteed by setting all parallel operated power supply units to exactly the same output voltage.

To ensure symmetrical distribution of power, we recommend designing all cable connections from the power supply unit to a busbar of the same length and with the same conductor cross section. The system makes it advisable to install a protective circuit at the output of each device when more than two power supply units are connected in parallel (e.g. decoupling diode or DC fuse). This prevents high reverse feed currents in the event of a secondary device fault.

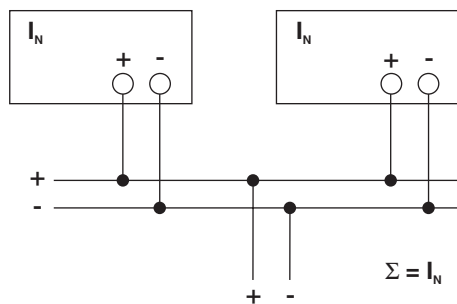

### Redundant operation

Redundant circuits are suitable for the supply of systems which make especially high requirements on the operational safety. If a fault occurs in the primary circuit of the first power supply unit, the second device automatically takes over the entire power supply, without interruption, and vice versa. For this reason, the power supply units to be connected in parallel are dimensioned in such a way that the total current requirement of all consumers can be completely covered by one power supply unit. 100% redundancy makes external decoupling diodes necessary (QUINT-DIODE/40, Order No. 2938963)!

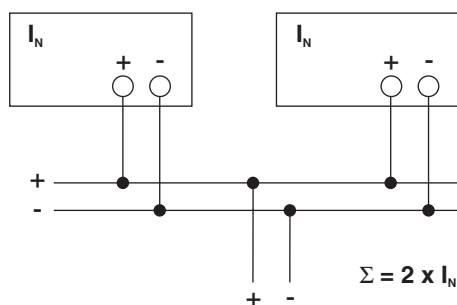

### Increased performance

For  $n$  parallel connected devices, the output current can be increased to  $n \times I_N$ . Parallel connection to increase efficiency is used for the expansion of existing systems. It is advisable to use parallel connection if the power supply unit does not cover the current requirement of the most powerful consumer. Otherwise the consumers should be spread among individual devices independent of one another. A maximum of five devices can be connected in parallel!



# SCATTERGOOD & JOHNSON LTD

ELECTRICAL ENGINEERING & FLUID CONTROL DISTRIBUTORS

Est.1899

At Scattergood & Johnson Ltd, we pride ourselves on being a technical distributor to specialist industries.

Working with a range of quality product suppliers across a number of specialist markets, we are not your average 'box shifter' - we are your technical and supply chain partner.

We fully support every product we sell - for free! Our internal team and external sales engineers can answer any product or application question, no matter the complexity.

Backing up this technical ability is a range of 50,000+ products available from stock for nationwide next day delivery (same day if required!), or you can collect what you need from any of our trade counters around the UK.

Select your specialist interest below to learn more about how we can help.



Online, In Branch and On the Road - Scattergood & Johnson Ltd, there when you need us.

# [www.scatts.co.uk](http://www.scatts.co.uk)