



## INTERFACE

### User Manual

#### SYS POWER SUPPLY UM E

Order No.: 27 45 85 5

Power Supply Units





## **INTERFACE**

### **User Manual**

### **Power Supply Units**

07/2005

---

Designation: SYS POWER SUPPLY UM E

Revision: 03

Order No.: 27 45 85 5

This manual is valid for:

All power supply units of the types

QUINT POWER, MINI POWER, and STEP POWER

## Please Observe the Following Notes

In order to guarantee the safe use of the product described, please read this manual carefully. The following notes give you information on how to use this manual.

### Qualifications of the User Group

The product usage described in this manual is exclusively aimed at electricians, or personnel trained by electricians, who are familiar with the valid national standards and other regulations on electrotechnology, in particular the pertinent safety concepts. Phoenix Contact assumes no liability for damage to any products resulting from disregard of information contained in this manual.

### Explanation of Symbols Used



The *attention* symbol refers to an operating procedure which, if not carefully followed, could result in damage to equipment or personal injury.



The *note* symbol informs you of conditions that must strictly be observed to achieve error-free operation. It also gives you tips and advice on hardware and software optimization to save you extra work.



The *text* symbol refers you to detailed sources of information (manuals, data sheets, literature, etc.) on the subject matter, product, etc. This text also provides helpful information for the orientation in the manual.

### We Are Interested in Your Opinion

We are constantly striving to improve the quality of our documents.

Should you have any suggestions or recommendations for improving the contents and layout of our documents, please send us your comments.

PHOENIX CONTACT GmbH & Co. KG  
Documentation Services  
32823 Blomberg  
GERMANY

Phone +49 - (0) 52 35 - 3-00  
Telefax +49 - (0) 52 35 - 3-4 20 21  
E-Mail [tecdoc@phoenixcontact.com](mailto:tecdoc@phoenixcontact.com)

**General Terms and Conditions of Use for Technical Documentation**

Phoenix Contact GmbH & Co. KG reserves the right to alter, correct, and/or improve the technical documentation and the products described in the technical documentation at its own discretion and without giving any notice.

The receipt of technical documentation (in particular data sheets, installation instructions, manuals, etc.) does not constitute any further duty on the part of Phoenix Contact GmbH & Co. KG to furnish information on alterations to products and/or technical documentation. Any other agreement shall only apply if expressly confirmed in writing by Phoenix Contact GmbH & Co. KG. Please note that the supplied documentation is a product-specific documentation only.

Although Phoenix Contact GmbH & Co. KG makes every effort to ensure that the information content is accurate, up-to-date and state-of-the-art, technical inaccuracies and/or printing errors in the information cannot be ruled out. Phoenix Contact GmbH & Co. KG does not offer any guarantees as to the reliability, accuracy or completeness of the information appearing on the Website. Phoenix Contact GmbH & Co. KG accepts no liability or responsibility for errors or omissions in the content of the technical documentation (in particular data sheets, installation instructions, manuals, etc.).

As far as is permissible by applicable jurisdiction, no guarantee or claim for liability for defects whatsoever shall be granted in conjunction with the information available in the technical documentation, whether expressly mentioned or implied. This information does not include any guarantees on quality, does not describe any fair marketable quality and does not make any claims as to quality guarantees or guarantees on the suitability for a special purpose. Phoenix Contact GmbH & Co. KG reserves the right to alter, correct, and/or improve the information and the products described in the information at its own discretion and without giving any notice.

## SYS POWER SUPPLY UM E

---

### **Statement of Legal Authority**

This manual, including all illustrations contained herein, is copyright protected. This manual is to be used for its intended purpose only, all other usage is prohibited. Reproduction, translation and public disclosure, as well as electronic and photographic archiving and modification require written consent by Phoenix Contact. Violators are liable for damages.

Phoenix Contact reserves the right to make any technical changes that serve the purpose of technical progress.

Phoenix Contact reserves all rights in the case of patent award or listing of a registered design. External products are always named without reference to patent rights. The existence of such rights shall not be excluded.

### **Internet**

You will find current information on products from Phoenix Contact on the Internet at:

[www.phoenixcontact.com](http://www.phoenixcontact.com).

All the latest Phoenix Contact documentation can be found on the Internet at:

[www.download.phoenixcontact.com](http://www.download.phoenixcontact.com).

# Table of Contents

1	General .....	1-1
2	Basics .....	2-1
	2.1 Mechanical Structure .....	2-1
	2.1.1 Open Frame Devices .....	2-2
	2.1.2 Enclosed Devices .....	2-3
	2.2 Electrical Structure .....	2-4
	2.3 Regulation Types .....	2-10
	2.3.1 Unregulated Devices .....	2-10
	2.3.2 Regulated Devices .....	2-11
	2.4 Converter Types.....	2-14
	2.4.1 Flyback Converter .....	2-15
	2.4.2 Forward Converter .....	2-19
	2.4.3 Push-Pull Converter .....	2-23
3	Useful Information from Everyday Practice .....	3-1
	3.1 Parallel Connection .....	3-1
	3.1.1 Parallel Connection for Increasing Power .....	3-3
	3.1.2 Parallel Connection for Designing Redundant Circuits .....	3-7
	3.2 Series Connection for Increasing Voltage (48 V DC).....	3-11
	3.3 Preventive Function Monitoring DC OK .....	3-12
	3.4 Adjustability of the Output Voltage .....	3-20
	3.5 Wide-Range Input .....	3-23
	3.6 Connection to Different Network Configurations .....	3-24
	3.7 Selective Protection by Means of Fusing in the Secondary Circuit.....	3-28
	3.8 Layout of External Primary-Circuit Fusing.....	3-31
	3.9 Layout of 24 V DC Supply Cables (Cable Cross Section).....	3-32
	3.10 Rating of the AC Low Voltage Supply Line .....	3-34
	3.11 Questions on EMC .....	3-35
	3.12 Pollution Degree.....	3-36
	3.13 Short-Term Mains Buffering .....	3-37
	3.14 Starting Behavior of the Power Supply Unit.....	3-38
	3.15 Output Characteristic Curves of Power Supply Units.....	3-39
	3.15.1 Fold-Back Characteristic .....	3-40
	3.15.2 U/I Characteristic .....	3-41
	3.15.3 U/I Characteristic With Power Boost .....	3-42
	3.16 Installation and Connection.....	3-43
	3.17 Emergency Stop Circuit .....	3-46

**SYS POWER SUPPLY UM E**

---

3.18	Harmonics .....	3-47
3.18.1	Harmonic Filter (Inductance) .....	3-51
3.18.2	PFC .....	3-52
3.19	Approvals .....	3-54
4	Selecting a Power Supply Unit .....	4-1
4.1	Supplying Electromechanical Components.....	4-3
4.2	Supplying Electronic Modules and Systems .....	4-3
4.3	Using Power Supply Units on Strongly Fluctuating Networks .....	4-4
4.4	Installation in Distributed Control Cabinets .....	4-4
4.5	Applications in Building Services Automation/Facility Management .....	4-5
4.6	Outlook.....	4-6
5	Product Overview .....	5-1
A	Appendices.....	A-1
A 1	List of Figures.....	A-1
A 2	Explanation of Abbreviations.....	A-5
A 3	Index .....	A-9

# 1 General

Power supply units have a great influence on the availability and operational safety of electrical systems. Therefore, the power supply unit should be chosen as carefully as all the other system components.

In the field of automation technology the innovation cycles are getting shorter and shorter. For this reason the system planner must concentrate on the major tasks. Universal power supply units must therefore meet all the demands required. This reduces work for the planner and increases electrical system reliability at the same time.

This manual will help you choose the right power supply unit for your needs. The "Basics" section provides information on the different types of power supply units. The following sections are intended to answer frequently asked questions, which arise when working with power supply units, and help you to choose the right device. At the end of this manual the complete product range of Phoenix Contact power supply units is listed.

**SYS POWER SUPPLY UM E**

---

## 2 Basics

This section introduces the most important basic terms with regard to "power supply units". This information will enable you to choose the power supply unit that best meets your requirements.

### 2.1 Mechanical Structure

#### Shock protection Foreign body protection Water protection

The mechanical structure and the housing of the device largely determine its compliance with safety regulations and thus the possible installation location of the power supply unit. According to EN 60529, particular attention must be paid to shock protection, foreign body protection and water protection. These degrees of protection are listed in the IP (International Protection) code.

#### IP20

Generally, IP20 protection is adequate for dry rooms and control cabinets. This degree of protection ensures reliable protection from touching live components and prevents penetration of foreign particles with a diameter of more than 12.5 mm (0.5 in.). Protection against water is not provided. If required, the devices are installed in a control cabinet, which itself ensures the desired degree of protection.

#### Shock resistance Vibration resistance

Further important parameters are the resistance of the power supply unit to shock and vibration.

The parameters "shock resistance" and "vibration resistance" provide information on what mechanical pressures the device structure will withstand. The shock resistance of devices is specified in IEC 60068-2-27. The vibration resistance is tested according to IEC 60068-2-6.

Solidly-constructed devices should be able to withstand vibration of 2.3g in the frequency range from 10 Hz to 150 Hz (g = gravitational acceleration).

Examples are devices for general industrial applications, power stations and devices used in the operating area of heavy rotating machine parts.

Shock resistance provides information on the operating and transport conditions of the devices. For industrial requirements, acceleration peaks of 30g over a shock period of 18 ms is considered sufficient. Power supply units tested according to these conditions can, in the completely installed control cabinet, be transported to the installation location without slipping from the mounting rail.

### 2.1.1 Open Frame Devices

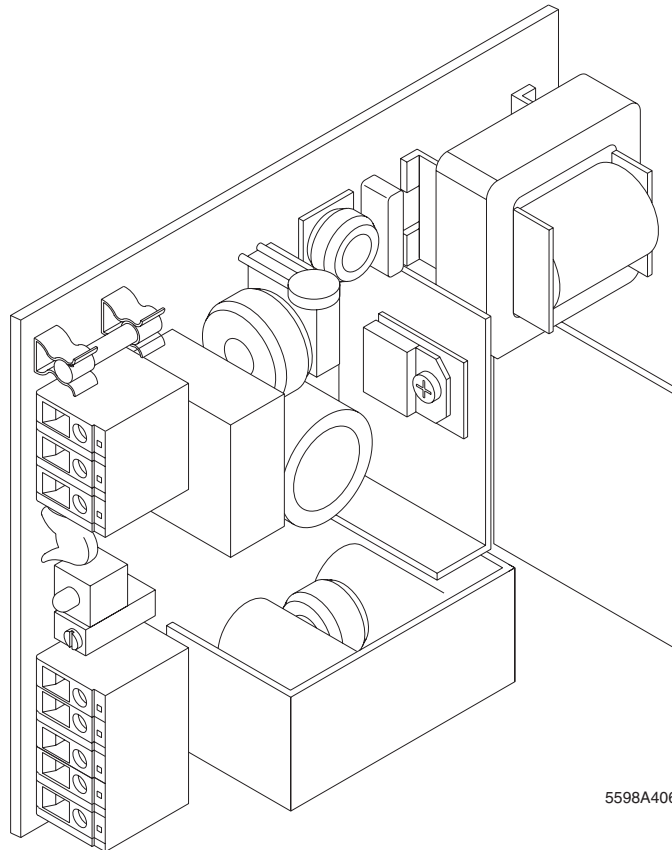
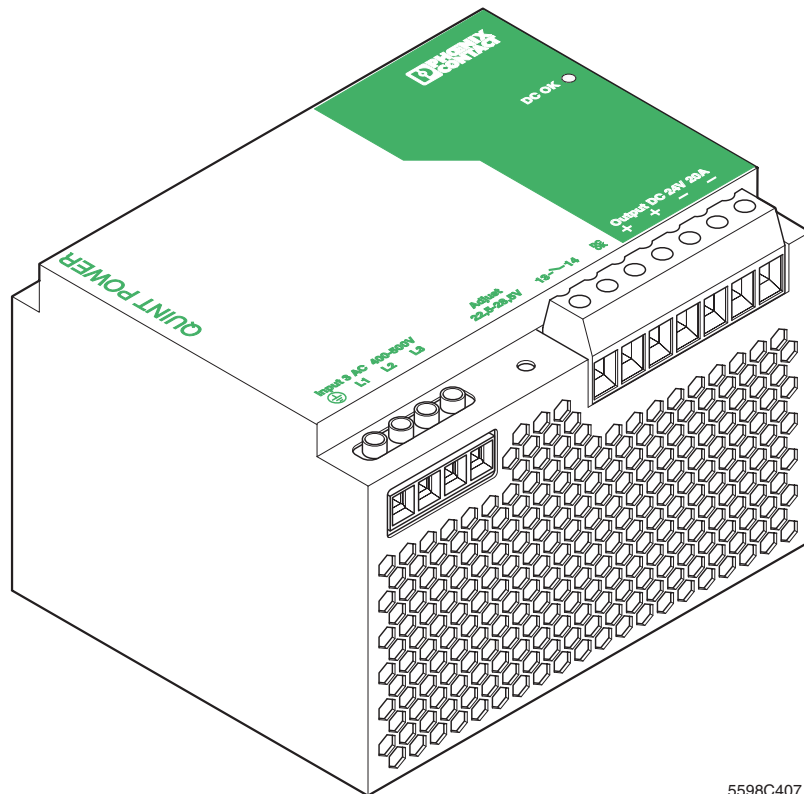

Figure 2-1 Open frame device

Power supply units constructed for 19" racks or as open frame modules are mainly used to supply single components within an existing housing (e.g., internal power supply of an oscilloscope).

Devices with an open frame structure correspond to IP00 protection. These devices are not protected against the penetration by foreign bodies or water.

## 2.1.2 Enclosed Devices



5598C407

Figure 2-2 Enclosed device (example: QUINT POWER 20A/3-phase)

Power supply units accommodated in a housing are known as "enclosed devices". These can be simple plug-in supply units for supplying portable domestic appliances or high-grade industrial power supply units for installation on standardized mounting rails.

These devices types are mainly designed with IP20 protection.

## 2.2 Electrical Structure

For power supply units a distinction is made between input and output variables. For a better understanding, the variables are illustrated in Figure 2-3.

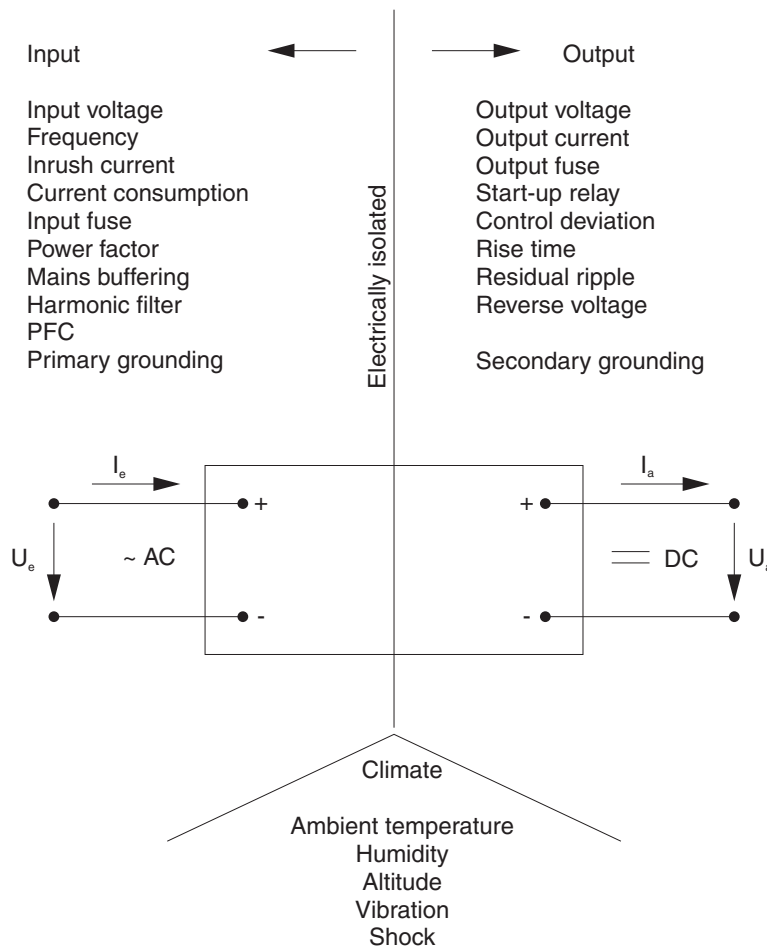

5598D003

Figure 2-3 Assignment of technical data

The electrical configuration of a power supply unit determines its operational safety, availability and the guaranteed protection of persons. Compliance with all safety parameters is of decisive importance.

<b>Class of protection</b>	<p>According to DIN VDE 0106 Part 1, electrical equipment (including power supply units) is divided into the classes of protection 0, I, II and III. Devices with class of protection 0 are not permitted in Germany.</p> <p>Compact power supply units are usually designed to meet class of protection I or II.</p> <p>The classes of protection each relate to the single device. To guarantee the safety of the entire system, all the wiring required must be implemented by trained personnel as defined in the current VDE guidelines and DIN standards.</p> <p><b>Devices with Class of Protection I</b></p>
<b>Protective earth ground (PE)</b>	<p>For devices with class of protection I protection against electric shock is not only based on the basic insulation. In addition, parts are connected to the protective conductor of the permanent installation in such a way that no voltage can remain even if the basic insulation fails. These devices are always provided with a protective earth ground connection (PE).</p> <p>QUINT POWER power supply units correspond to class of protection I. These units are usually grounded using the PE connection on the input terminal. The power supply unit is electrically connected to the mounting rail via the mounting rail adapter. PE connection via the terminal point is not required if the mounting rail is grounded.</p> <p><b>Devices with Class of Protection II</b></p> <p>For devices with class of protection II protection against electric shock is not only based on the basic insulation. In addition, a double or reinforced insulation is used. There is no possibility for connecting a protective conductor for these devices. With regard to safety the device is therefore independent of installation conditions.</p> <p>Due to their good insulation concept and the non-conductive housing, MINI POWER and STEP POWER power supply units from Phoenix Contact do not require any protective conductor. Class of protection II is obtained when the unit is installed in a closed control cabinet.</p>
<b>Electrical isolation</b>	<p>A further requirement for the professional use of a power supply unit is electrical isolation. It is essentially determined by the insulation, the transformer and a suitable closed-loop control circuit. For power supply units with electrical isolation there is no continuous conductive connection from the device input to the device output.</p> <p>When designing the insulation, it is the task of the manufacturer to select a suitable insulating material and to provide clearances that are large enough. Besides other parameters the insulation voltage and the maximum installation altitude of the devices depend on the choice of insulation clearances.</p>
<b>Installation altitude</b>	<p>Power supply units designed according to DIN VDE 0110 Part 1 are suitable for installation altitudes up to 2000 m (6562 ft.) above sea level, minimum.</p>

## SYS POWER SUPPLY UM E

---

### Safe isolation

According to DIN VDE 0106 Part 101, two circuits are safely isolated if there is an adequate degree of certainty that the voltage of one circuit cannot affect the other circuit. This includes a careful choice of the insulation, the use of safety transformers and complete electrical isolation including the isolation of the closed-loop control circuit by optocouplers.

Primary switched-mode QUINT POWER, MINI POWER and STEP POWER power supply units have been tested with regard to safe isolation according to DIN VDE 0100-410, DIN VDE 0106-1010 and EN 61558-2-17.

DIN VDE 0555/EN 60742 deals with electrical safety of isolation transformers and safety transformers with a rated frequency of more than 500 Hz.

Due to the system, primary switched-mode power supply units are not provided with a transformer according to DIN VDE 0551 but with a transformer operating at a frequency of 40 kHz to 180 kHz. Because of these high frequencies transformers of primary switched-mode power supply units cannot be tested according to DIN VDE 0551.

DIN VDE 0570-2-17/EN 61558-2-17 is a subsequent standard to DIN VDE 0551. It deals with the safe isolation of transformers with an increased rated frequency and is used as a basis for testing transformers of primary switched-mode power supply units.

Because the power supply units are safely isolated there is no need for expensive isolating transformers in order to comply with DIN VDE 0551.

### SELV Safety Extra Low Voltage

The Safety Extra Low Voltage (SELV) is always kept if, on the one hand, overspill of a voltage from one circuit into another is prevented and, on the other hand, safety extra low voltages with a nominal voltage of  $U_N \leq 50 \text{ V AC}$  or  $120 \text{ V DC}$  are not exceeded.

For keeping the SELV, secondary grounding is permissible but not required.

### PELV Protective Extra Low Voltage

For keeping the PELV, secondary grounding is absolutely necessary. Otherwise, the same regulations apply as for keeping the SELV.

**Secondary grounding**

The secondary grounding ensures reliable protection in case of ground faults in DC circuits of electrical systems. Ground faults may lead to dangerous situations for persons and machines.

A ground fault is an impermissible conductive connection to PE, e.g., if the bare wire touches a grounded housing as a result of a damaged insulation.

Figure 2-4 shows that ground faults are extremely critical when occurring in the current path between the secondary fuse and load. A double ground fault in this area leads to a short circuit across the switch in the worst case and thus to an unintentional machine start.

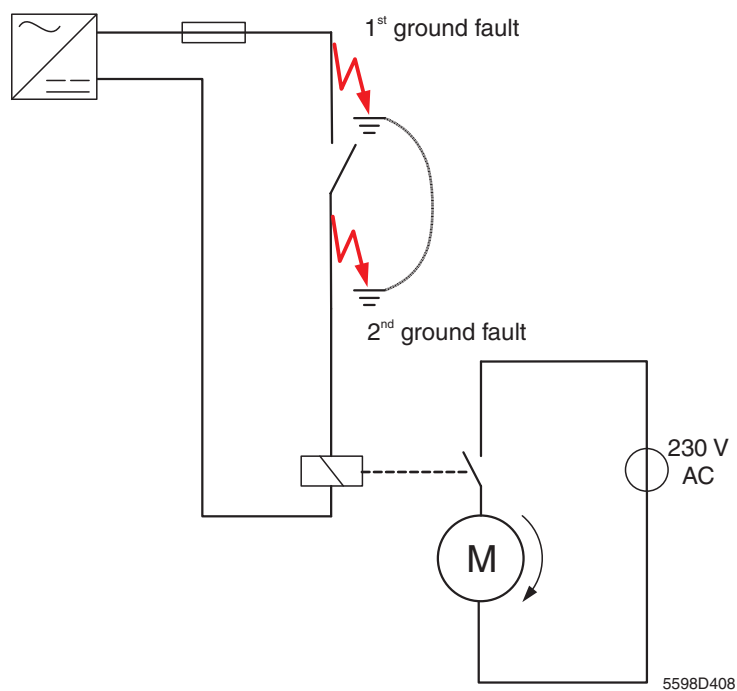

Figure 2-4 Without secondary grounding

**SYS POWER SUPPLY UM E**

Reliable protection can be obtained by grounding the safety extra low voltage after PE on the secondary side at a defined position. Ideally, the secondary grounding is established directly on the output terminal of the power supply unit as shown in Figure 2-5. If, in this way, the first ground fault is generated intentionally and at a defined position, every other unintentional ground fault will cause an output voltage short circuit in the critical area between the fuse and the load. This will cause the fuse to blow and the faulty area of the electrical system to shut down. In this way persons and machines are being protected.

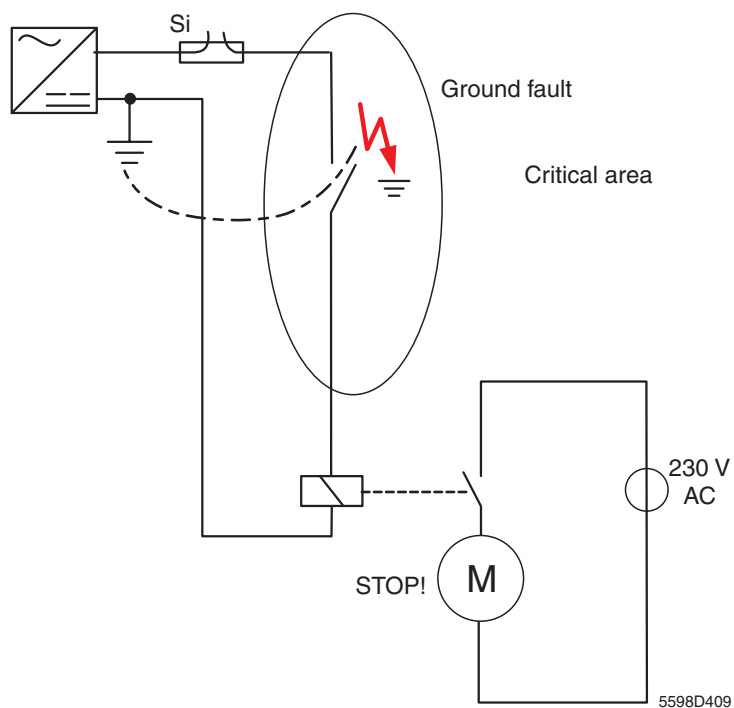
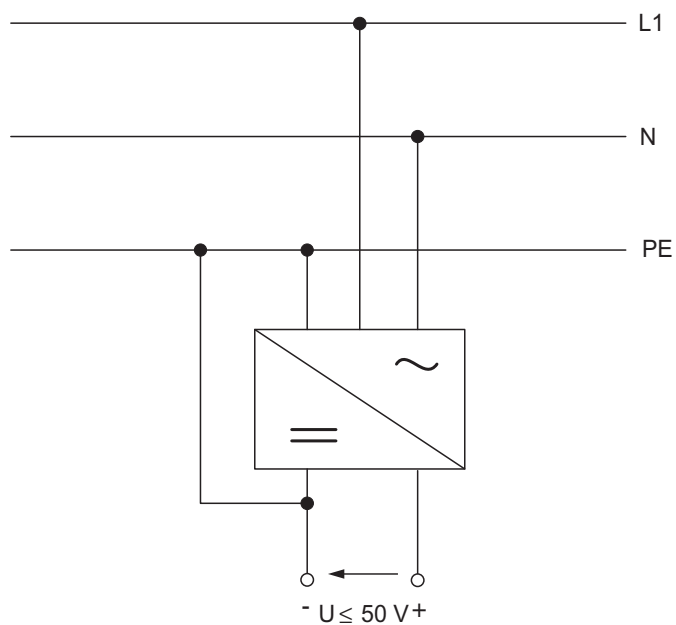

Figure 2-5 With secondary grounding

Figure 2-6 shows how the secondary grounding of the safety extra low voltage to PE according to VDE 0100-410 can be created.



5598D410

Figure 2-6 Secondary protection

## 2.3 Regulation Types

Apart from the mechanical and electrical structure, the type of regulation is of major importance for the choice of a power supply unit.

A distinction must generally be made between regulated and unregulated devices.

### 2.3.1 Unregulated Devices

#### Voltage fluctuations at the output, good efficiency

With unregulated devices, the AC line voltage is transformed using a 50 Hz transformer and then rectified. The pulsating DC voltage resulting from this process is smoothed and filtered using capacitors.

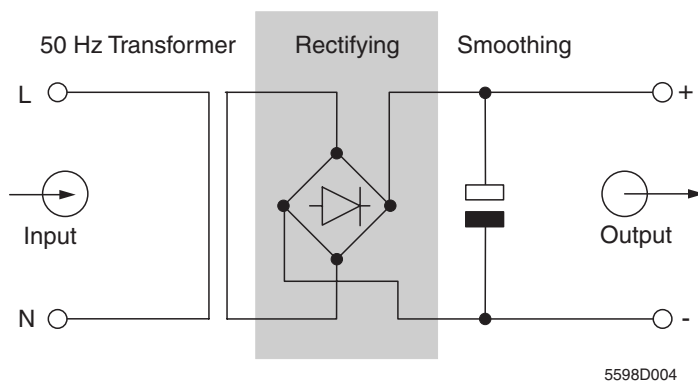

5598D004

Figure 2-7 Circuit diagram for unregulated devices

Because of its few components this relatively simple circuit has the advantage of a particularly long service life and a typical efficiency of 80%.

Due to the missing control level, output voltage fluctuations will occur in the case of fluctuating input voltages and fluctuating current output.

Unregulated devices are used for supplying electromechanical loads such as contactors, electromagnetic switches etc., which do not require a regulated output voltage.

### 2.3.2 Regulated Devices

#### Series controller Primary-switched controller

Two types of regulated power supply units have been successfully implemented: On the one hand, the widely distributed series controllers and on the other hand, the primary switched-mode controllers. Success in the development of power electronics has contributed to primary switched-mode power supply units gaining more and more importance.

#### Linearly Regulated Devices

#### Constant output voltage, poor efficiency

With linearly regulated devices, the AC line voltage is transformed using a 50 Hz transformer and then rectified. The pulsating DC voltage is smoothed and filtered using capacitors. Up to there, the technical configuration is very similar to the one of the unregulated device.

After rectification, linearly regulated power supply units either have a DC series controller or a DC quadrature controller in the form of a power transistor, which functions as a variable resistor. Depending on the forward DC resistance of the transistor, the current flowing through the load is regulated in such a way that the voltage across the load remains constant.

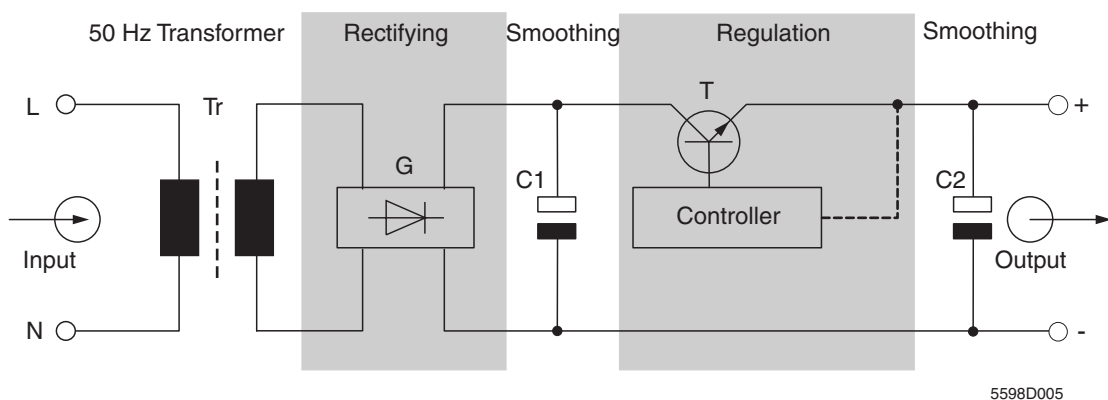

Figure 2-8 Circuit diagram for linearly regulated devices

The efficiency of these circuits is approximately 40% to 60%, depending on the circuit structure. The power dissipation consists of the losses in the 50 Hz transformer, the rectifier, the transistor and the closed-loop control circuit.

The transformer must be designed large enough to provide useful power and power dissipation. This means an increased size of the transformer of at least 50%.

The field of electronics is the optimum application for these devices. Here, a precisely regulated 24 V DC voltage, which is as free as possible from harmonics, is required.

## SYS POWER SUPPLY UM E

## Regulated Primary Switched-Mode Devices

**Constant output voltage,  
good efficiency**

In primary switched-mode power supply units the AC line voltage is first rectified. The DC voltage generated in this way is then smoothed and chopped or switched. This is carried out periodically by a power transistor at frequencies from 40 kHz to 180 kHz. The square-wave voltage resulting from this process is transformed by means of a high-frequency transformer.

The main difference between primary switched-mode devices and linearly regulated devices is that primary switched-mode controllers first rectify and then transform, whereas linear controllers first transform and then rectify.

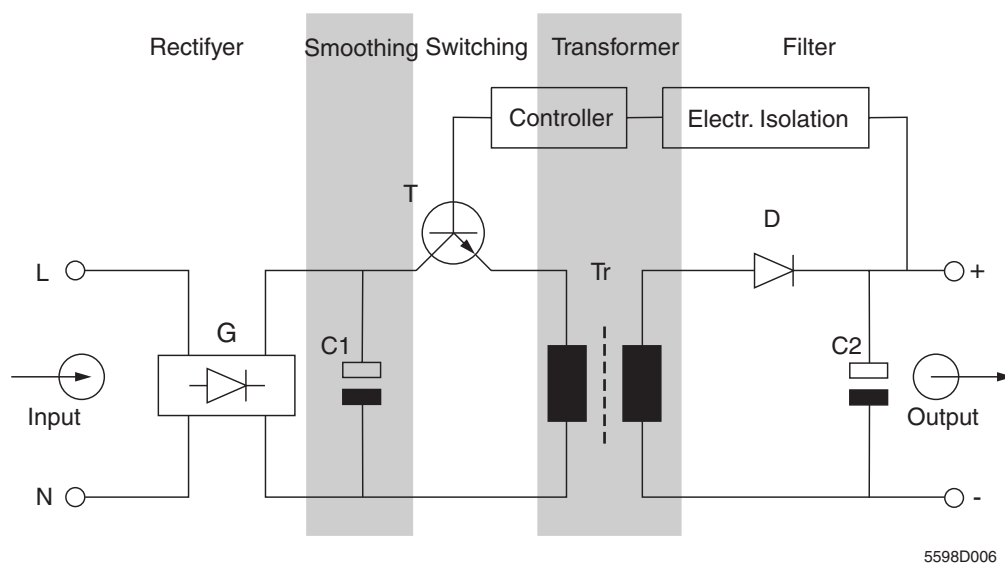

Figure 2-9 Circuit diagram for primary switched-mode devices

Because the frequency at which the voltage is transformed is very much higher than the line frequency, the volume and thus the weight of the magnetic transformer can be reduced considerably.

If the transistor is used as a variable resistor in linearly regulated devices, it operates as a switch in primary switched-mode controllers. This reduces the power dissipation considerably.

In the secondary circuit the pulsating DC voltage is again smoothed. The output voltage is regulated depending on the load using the amount of energy transferred in one period. The amount of energy transferred can be varied by the pulse duty factor  $P$ .

$$P = (t_{ON}) / (t_{ON} + t_{OFF}).$$

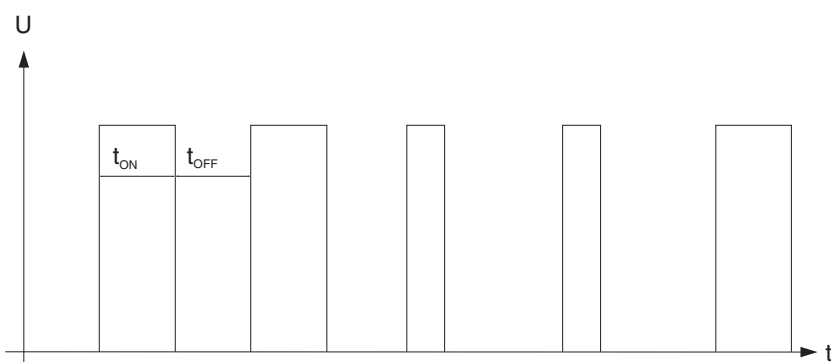

5598D007

Figure 2-10 Pulse duty factor diagram



The efficiency of primary switched-mode devices is 80% to 90% - much better than the efficiency of linearly regulated devices. Therefore, in a primary switched-mode device less heat loss is generated and the relatively small transformer needs to provide only a small amount of dissipated power.

### Light and compact

Circuits based on the primary switched-mode controller principle enable the design of extremely light and compact devices.

Primary switched-mode devices are intended for general use in the field of automation technology. Low heat loss, compact design and a wide input voltage range make these devices ideally suitable for use in distributed junction boxes.

### Example

The following example will illustrate the advantages of primary switched-mode power supply units in contrast to linearly regulated devices by comparing the power dissipation.

Modern primary switched-mode power supply units have a typical efficiency greater than 90%. This results in a total power dissipation of only about 75 W for an output voltage of 24 V DC and an output current of 40 A.

The typical efficiency of 50% of a linearly regulated device results in a power dissipation of about 500 W. Dissipation occurs in the form of heat, which causes the control cabinet temperature to rise unnecessarily.

## 2.4 Converter Types

For use in primary switched-mode power supply units different types of converters have proved to be effective. Generally, a distinction must be made between single-ended converters and push-pull converters.

Single-ended converters are the simplest primary switched-mode power supply units.

The most important converter types are described in Figure 2-11.

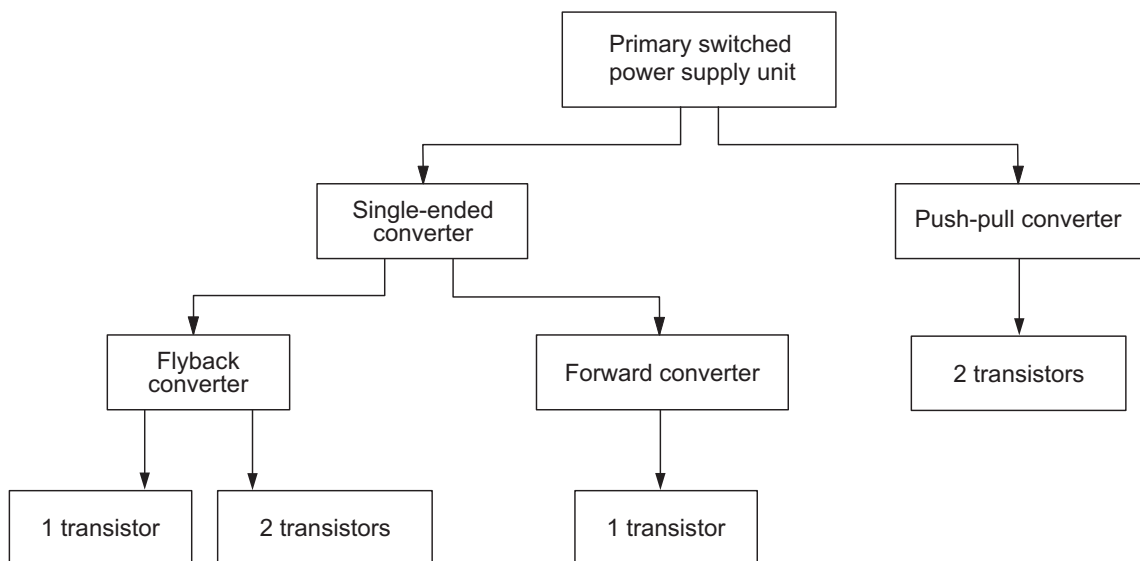

5598D411

Figure 2-11 Converter types

### 2.4.1 Flyback Converter

Flyback converters enable wide distribution of "low" power. Up to now, flyback converters have only been used in power supply units with up to 200 W, approximately. Thanks to more powerful components with reduced power dissipation, flyback converters can now be used for power supply units with an output power of up to 1000 W, approximately.

Flyback converters are categorized according to the number of power switches used. Up to 200 W, flyback converters require one power switch. Up to 1000 W, each flyback converter uses two power switches.

Flyback converters consist of a smaller number of components than forward converters. For this reason, devices with flyback converters have a light and small design and operate particularly reliably.

Therefore, all QUINT POWER, MINI POWER and STEP POWER power supply units from Phoenix Contact are designed as flyback converters. They cover a performance range from 15 W to 960 W.

#### Method of Operation

Figure 2-12 shows the simplified structure of a flyback converter with one power switch.

The power switch S1 is switched on and off by means of a controller with the control voltage  $U_{ctrl}$ . The value of the output voltage  $U_{out}$  depends on the winding factor of the transformer Tr and the pulse duty factor of switch S1. The value of the output voltage  $U_{out}$  is continuously measured and transmitted to the controller. In this way, a stabilized output voltage  $U_{out}$  is generated.

Because of the switching process the energy transport in the flyback converter is carried out in two steps. For easier understanding, the procedures are illustrated in two different graphics.

Figure 2-12 shows the circuit with switch S1 closed. During this operating cycle an amount of energy is taken from the supplying network and stored in the transformer Tr.

Figure 2-13 shows the circuit with switch S1 opened. The energy stored in the transformer is passed on to the secondary circuit.

The corresponding characteristic curves of the voltage and current are shown in Figure 2-14.

SYS POWER SUPPLY UM E

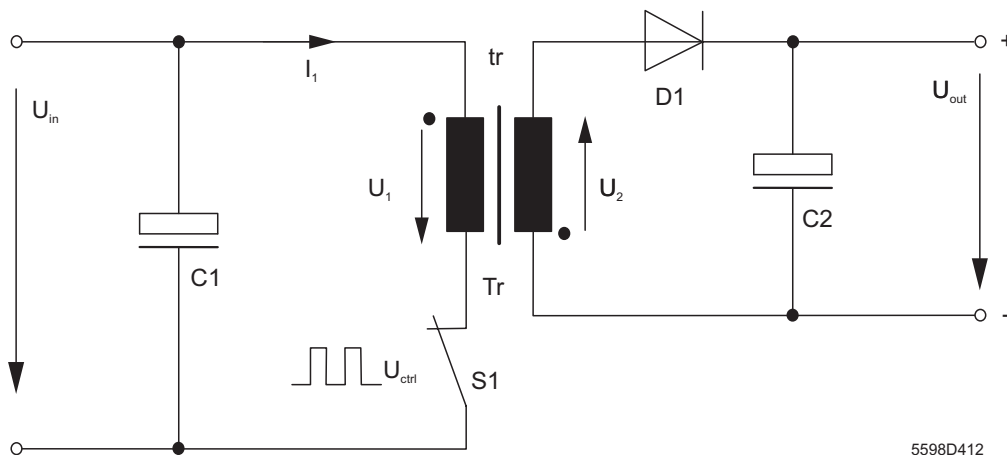

Figure 2-12 Flyback converter with switch S1 closed

The rectified line voltage  $U_{in}$  is applied to the input of the flyback converter. Capacitance  $C1$  is used as temporary storage because the energy is stored there during the off-state phase. When power switch  $S1$  is closed, the primary voltage of the transformer  $U_1$  is equal to the input voltage  $U_{in}$ . A constantly rising current  $I_1$  is flowing through the primary winding of transformer  $Tr$ . During this time the transformer  $Tr$  consumes magnetic energy and stores it in the air gap.

Because of the differential winding sense voltages  $U_1$  and  $U_2$  on the primary and secondary winding are opposite to each other. There is no current flow through the secondary winding because diode  $D1$  is in the off state. No energy is transferred into the output circuit.

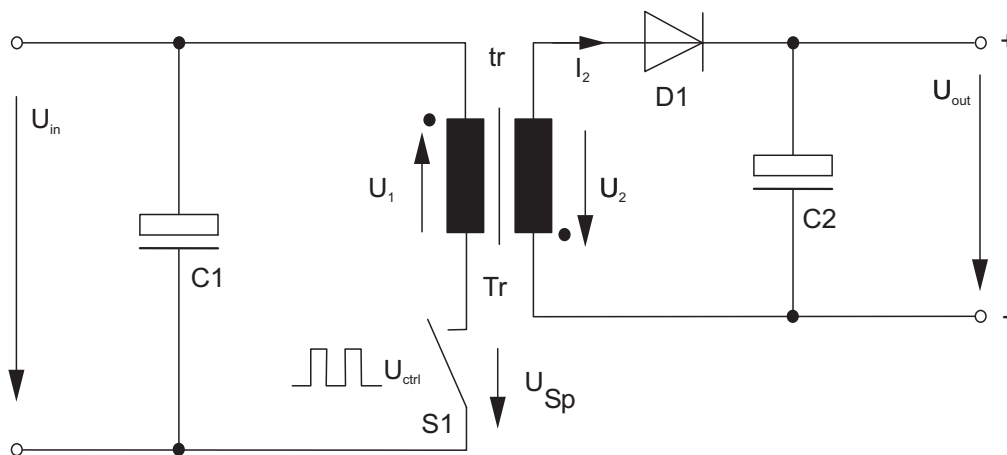
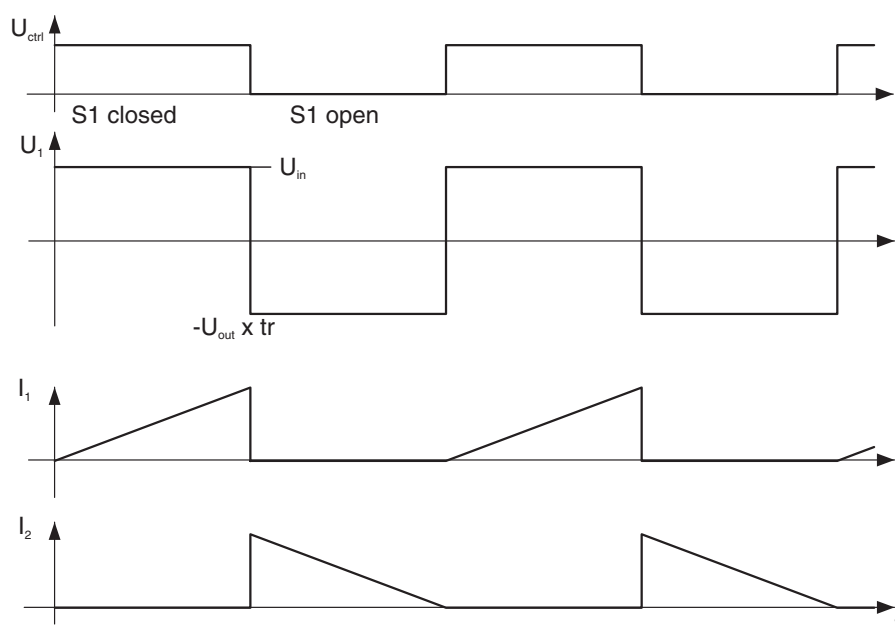

Figure 2-13 Flyback converter with switch S1 opened

If the power switch S1 is opened the polarity of the voltages  $U_1$  and  $U_2$  on the transformer Tr is reversed according to Faraday's law. The transformer is now acting as a current source. Diode D1 becomes conductive and forwards the stored energy to capacitance C2.

In this type of converter energy is not transported continuously. Energy is only transmitted to the output circuit if power switch S1 is opened. Therefore this type of converter is known as flyback converter. If power switch S1 is closed the flow of energy into the output circuit through diode D1 is interrupted. Capacitance C2 then again generates a continuous energy flow from the transmitted energy in the output circuit.

For the flyback converter the transformer Tr is acting as a temporary storage. The load connected to the output does not directly affect the input voltage source. Only the energy stored in the transformer Tr is available in the output circuit. Due to this power limitation flyback converter outputs are short-circuit-proof.



5598D414

Figure 2-14 Characteristic curves of voltage and current for flyback converters

## SYS POWER SUPPLY UM E

**Flyback Converters With Two Power Transistors**

For the performance range from 200 W to 1000 W flyback converters with two power transistors are used. These power transistors are controlled in parallel. The principle of function of this flyback converter is very similar to the basic principle mentioned above.

The two power switches in the primary circuit now require two diodes. The secondary circuit remains unchanged with regard to the basic principle of the flyback converter.

Using two power switches and diodes divides the reverse voltage  $U_{rev}$  in two for every power switch. Smaller power switches with reduced dissipation can be used.

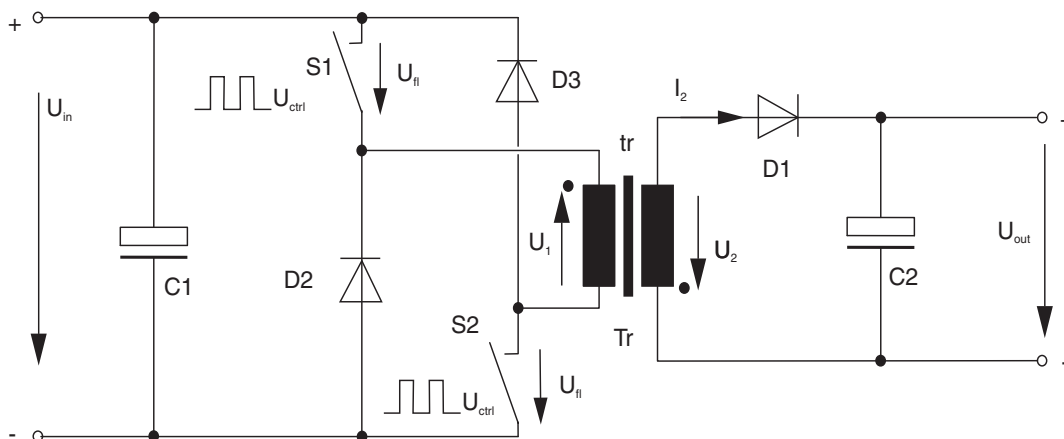

5598D415

Figure 2-15 Flyback converter with two transistors

## 2.4.2 Forward Converter

Primary switched-mode power supply units with an output power of greater than 200 W used to be designed with forward converters. Today, flyback converters may be used for an output power of up to 1000 W. Therefore, forward converters are more and more being replaced by space-saving and reliable flyback converters, also for higher performance ranges. The following section explains the circuit principle of forward converters.

The major difference between a flyback converter and a forward converter is that in the forward converter the energy transport from the primary to the secondary circuit is carried out with the switch closed. The forward converter owes its name to this principle.

The design of the forward converter is more complicated than the design of the flyback converter. The transformer requires an additional primary winding and the output circuit additional diodes and an inductance. This makes forward converters larger in size and heavier than flyback converters.

### Method of Operation

Figure 2-16 shows the simplified structure of a forward converter.

The power switch S1 is switched on and off by means of a controller with the control voltage  $U_{ctrl}$ . The value of the output voltage  $U_{out}$  depends on the pulse duty factor of switch S1. The value of the output voltage  $U_{out}$  is continuously measured and transmitted to the controller. In this way, a stabilized output voltage  $U_{out}$  is generated.

Energy transport in the forward converter is carried out in two steps. For easier understanding, the procedures are illustrated in two different graphics.

Figure 2-16 shows the circuit with switch S1 closed. During this operating cycle energy is taken from the supplying network and transformed into the output circuit.

Figure 2-17 shows the circuit with the switch opened. In this operating cycle no energy is transformed into the secondary circuit. Storage inductance L1 avoids interruptions of the energy flow in the secondary circuit.

The corresponding characteristic curves of the voltage and current are shown in Figure 2-18.

SYS POWER SUPPLY UM E

If switch S1 is closed the current  $I_1$  flows through the primary winding N1 of the transformer Tr. As with the flyback converter, one part of the current  $I_1$  is stored in the transformer Tr in the form of magnetic energy. Unlike the flyback converter the windings N1 and N2 have the same winding sense. As a result, the current  $I_1$  induces the square-wave voltage  $U_2$  of the same polarity in the secondary winding N2. The voltage  $U_2$  causes the current  $I_2$  to flow across diode D1 and the current  $I_3$  to flow across the inductance L1. It also loads the capacitance C2. Inductance L1 stores one part of the current  $I_3$  in the form magnetic energy.

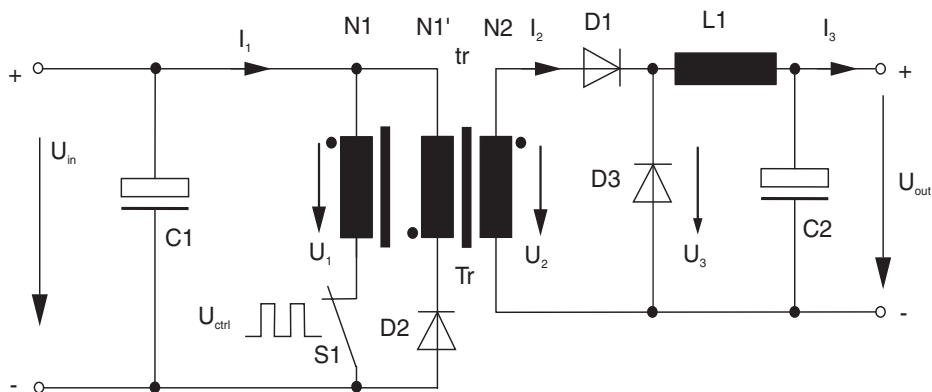

5598D416

Figure 2-16 Forward converter with power switch S1 closed

If the power switch S1 is opened, the polarities on the windings N1 and N2 are reversed. Diode D1 in the output circuit is now in reverse direction. Windings N1 and N2 are at zero current. As a result, the energy flow from the primary to the secondary circuit is interrupted. The energy stored in inductance L1 avoids interruptions of the energy flow in the secondary circuit. The storage inductance L1 avoids interruptions of the current  $I_3$  using the free-wheeling diode D3.

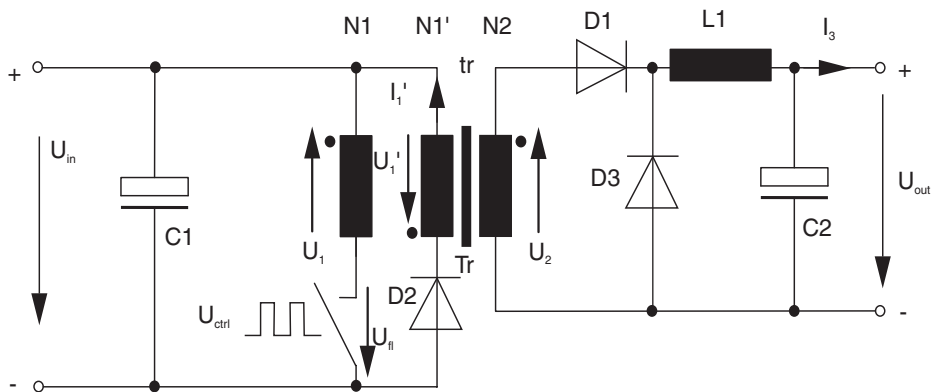

5598D417

Figure 2-17 Forward converter with power switch S1 opened

In order for the transformer  $T_r$  to be available for the maximum energy flow after re-closing the power switch  $S_1$ , the remaining magnetic energy in the transformer  $T_r$  must be discharged when the power switch  $S_1$  is open.

Because of the reversing diode  $D_1$  the secondary circuit is not available. This requires an additional winding  $N_1'$  in the primary circuit. The winding discharges the magnetic energy.

The winding  $N_1'$  consumes the magnetic energy and leads it back to capacitance  $C_1$  across diode  $D_2$  in the form of electrical energy. This energy is then again available for transmission into the output circuit when closing switch  $S_1$ .

Both primary windings  $N_1$  and  $N_1'$  often have the same number of turns but an opposite winding sense. Therefore, the time required for energy storage and energy discharge is the same. Power switch  $S_1$  must be opened for the same time as it was closed before.

The reverse voltage  $U_{rev}$  is the sum of the inverse transformation voltage  $U_1$  and the input voltage  $U_{in}$ . It is present at the opened power switch  $S_1$ . The reverse voltage of conventional forward converters is lower than the reverse voltage of flyback converters with one power switch. For a long time, this was the reason for only designing forward converters for this performance range.

SYS POWER SUPPLY UM E

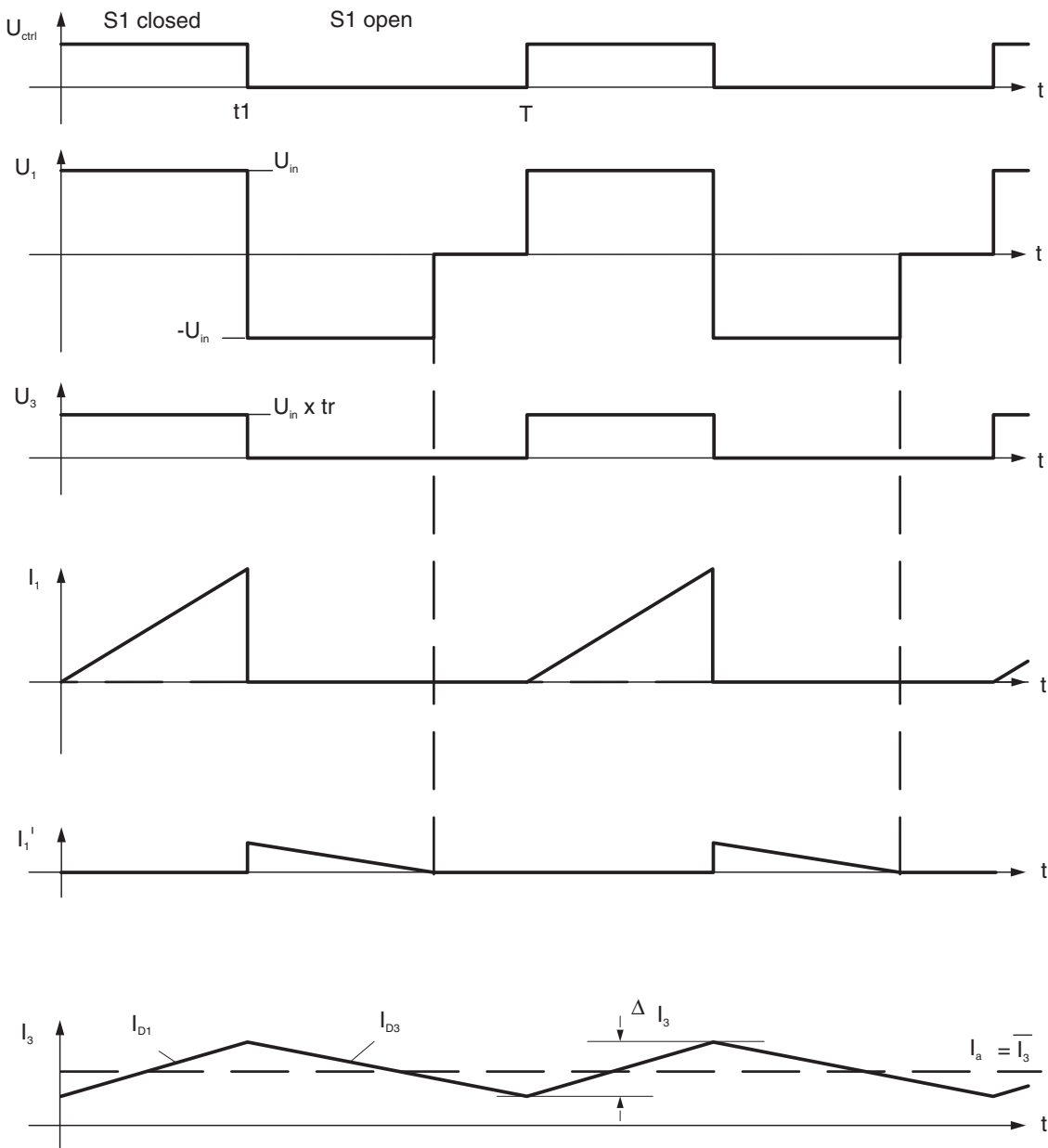

5598D418

Figure 2-18 Characteristic curves of current and voltage for forward converters

### 2.4.3 Push-Pull Converter

Push-pull converters are used for very high performance ranges beginning at 1000 W. Basically, a push-pull converter consists of two forward converters and therefore always has two power switches. Using push-pull converters, every clock is used for power transmission. As a result, the output power is much higher compared to forward converters.

As with flyback and forward converters, the rectified line voltage  $U_{in}$  is used as the input voltage. The power switches S1 and S2 in the primary circuit are switched alternately by means of the control voltage  $U_{ctrl}$ . Both switches are never closed at the same time. Otherwise, there would be no input short circuit. Each switching process of S1 and S2 causes the polarity of the primary winding N1 to change. The transformer is thus operated with an AC voltage.

In every switching phase of S1 and S2 the transformer Tr transmits power into the output circuit. This power is then rectified by the alternately conductive and reversing diodes D1 to D4.

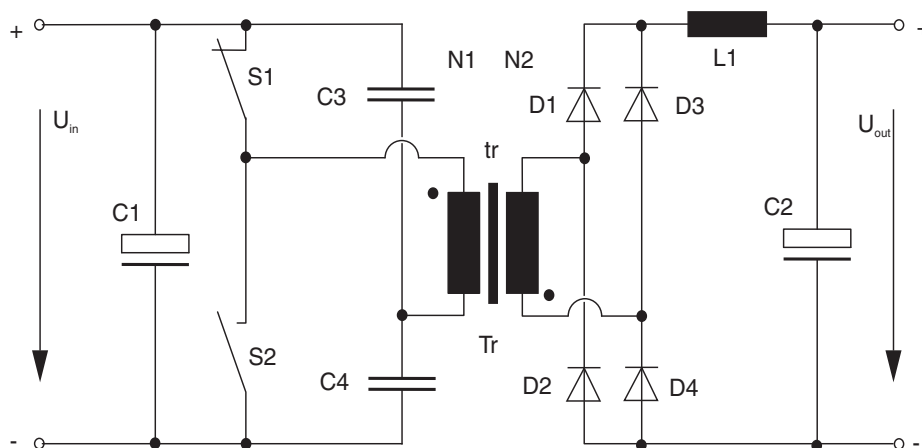

5598D419

Figure 2-19 Half-bridge push-pull converter

**SYS POWER SUPPLY UM E**

---

### 3 Useful Information from Everyday Practice

Questions arising from practical work are being answered in this section. The questions have been sorted by subjects and serve as a reference work for the user, both in the planning stage and when maintaining and expanding existing systems.

#### 3.1 Parallel Connection

Only specifically designed power supply units can be connected in parallel. The systems engineer can pursue two different objectives using parallel connection:

##### Increasing power/ Redundancy

- Increasing power: The existing power supply unit is no longer adequate for the supplying the expanded system.
- Redundancy: Operation can be maintained in the event of a power supply failure.

For both objectives, the total power should be distributed as uniformly as possible onto the single units. Voltage balancing is required for all power supply units with adjustable output voltage if the default 24 V output voltage has been set to a different value. Voltage balancing is shown in Figure 3-1 and Figure 3-2.

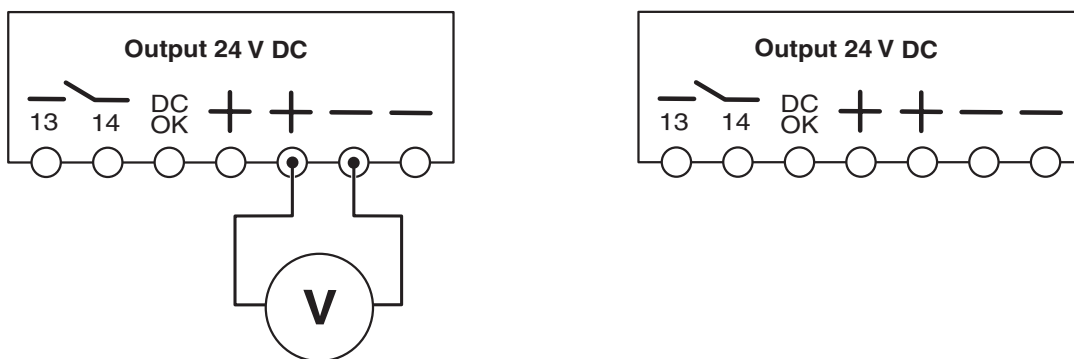

5598D021

Figure 3-1 Voltage balancing (1st step)

## SYS POWER SUPPLY UM E

### Device balancing

1. Power supply unit 1 is in operation and at no-load mode. The desired output voltage is set via the potentiometer using a voltmeter (see Figure 3-1).

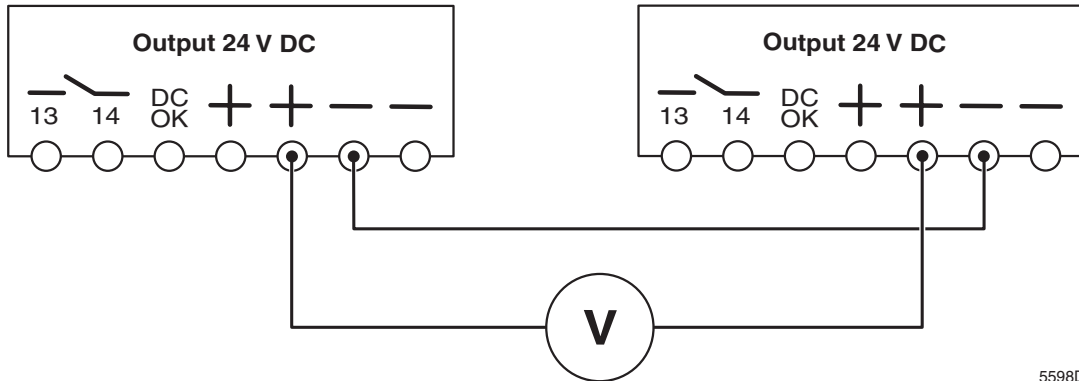

5598D008

Figure 3-2 Voltage balancing (2nd step)

2. Both power supply units and the voltmeter are connected as shown in Figure 3-2. Both power supply units are in operation and at no-load mode. Balancing of the power supply units is carried out by means of differential voltage measurement. For this, the output voltage of power supply unit 2 is adjusted using the potentiometer until the voltmeter no longer measures any voltage. Both output voltages are exactly set if the differential voltage between both power supply units is 0 V. The lower the differential voltage of the power supply units 1 and 2 the more symmetrical the distribution of the total current for the two single units.

### 3.1.1 Parallel Connection for Increasing Power

#### Field of application System expansion

Parallel connection for increasing power is used when expanding existing systems. Parallel connection is only required if the most powerful load requires more current than the existing power supply unit can supply. It is recommended in all other cases to distribute the loads on individual devices independent from each other.

24 V DC devices with an output power of 15 W to 960 W are available as single units from the Phoenix Contact product range.

#### Example

#### Problem 1

In an existing system, three loads with a total current consumption of 18 A (5 A/5 A/8 A) are being supplied from a single 20 A device.

With a system expansion an **additional** load of 16 A must be supplied.

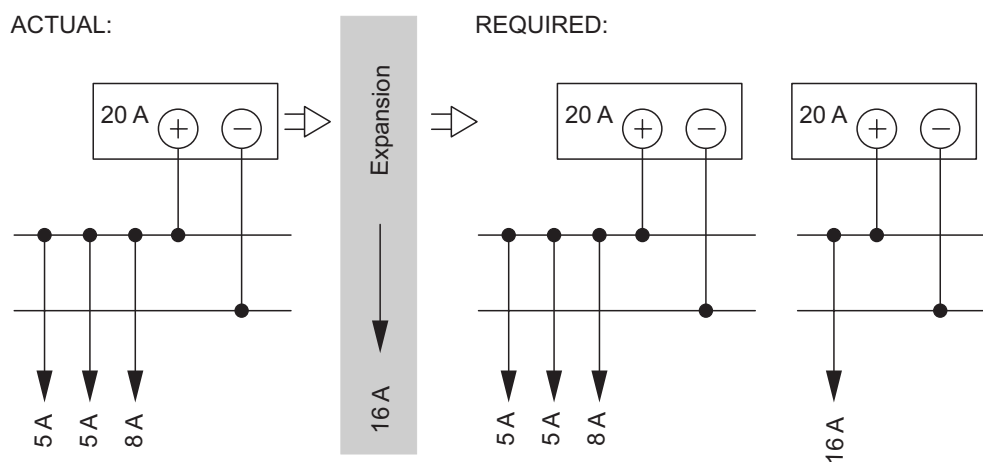

5598D023

Figure 3-3 Example with additional load

#### Solution

The best technical solution, which also has the lowest wiring costs, is to operate the existing loads on the 20 A power supply unit. A further 20 A power supply unit is installed as a single device for the additional 16 A load.

**SYS POWER SUPPLY UM E**

**Problem 2**

The existing 5 A load from the system described in problem 1 is to be replaced by a 25 A load.

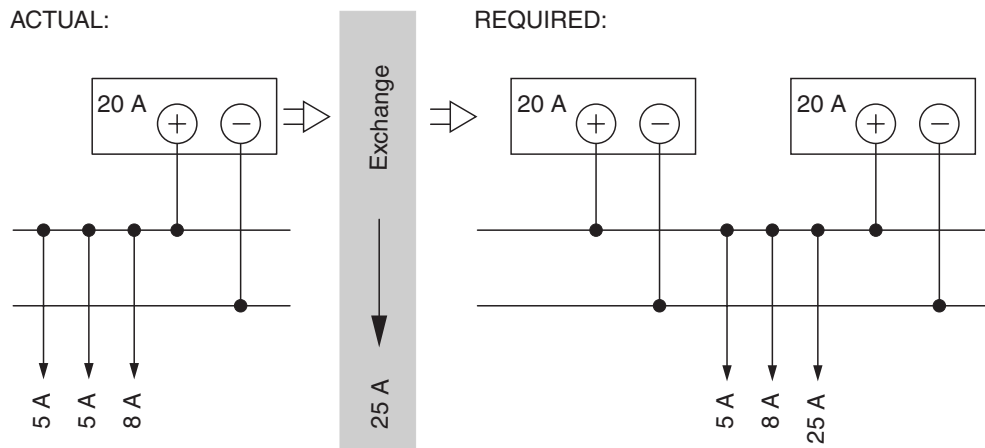

5598D022

Figure 3-4 Example with 25 A load

**Solution**

A single 20 A device cannot supply this load with electrical energy on its own. In order to avoid increased investment costs for a 40 A power supply unit a second 20 A power supply unit is connected in parallel to the existing 20 A power supply unit.

This makes 40 A output current available to supply the total load of 38 A (5 A/25 A/8 A).



Power supply units of the same type, QUINT POWER, MINI POWER and STEP POWER, can be connected in parallel for increasing power.

## Tips for Implementation

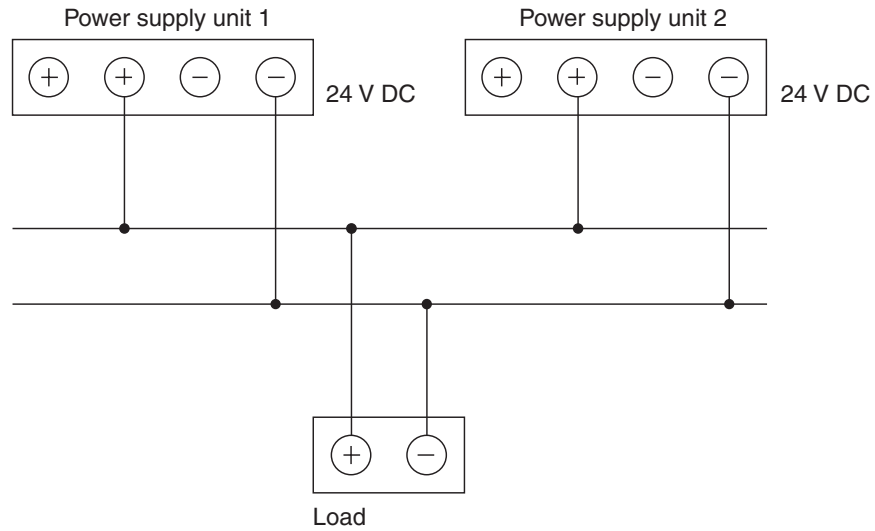

5598D009

Figure 3-5 **Correct** parallel connection in the secondary circuit

All cable connections must have the same length and the same cross section from the power supply unit to the busbar.

## SYS POWER SUPPLY UM E



The devices must **never** be connected as shown in Figure 3-6. Otherwise, the connection terminals might be overloaded.  
All devices with COMBICON connections must only carry a load of 20 A on each terminal point.

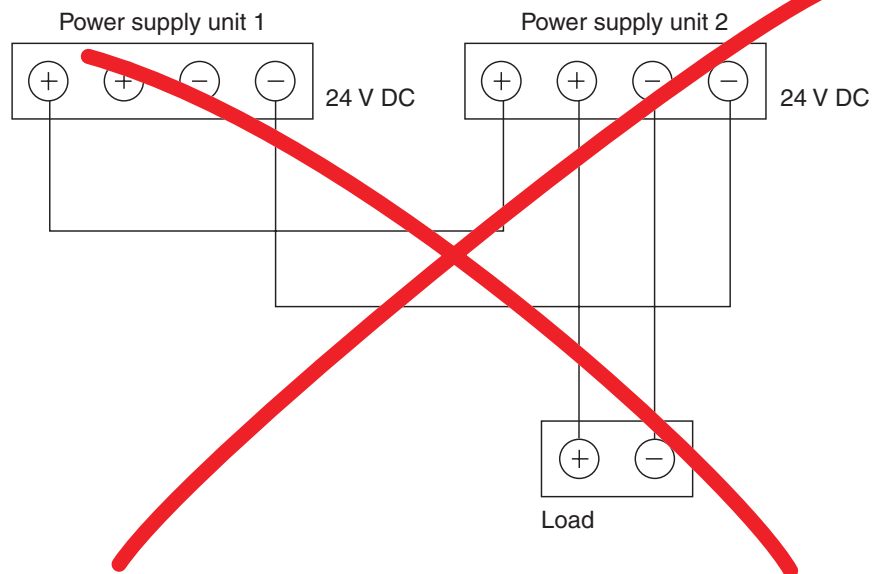

5598D010

Figure 3-6 **Incorrect** parallel connection in the secondary circuit

### Uniform current distribution

For a uniform current distribution to the power supply units connected in parallel it is useful to clamp a "+" and a "-" busbar from the 24 V DC outputs. All cables of the power supply units to this busbar should have the same length and the same cross section.

The cable cross sections in the secondary circuit should be large enough to keep the voltage drops on the cables as low as possible.

For cable connections in the primary circuit, please refer to section 3.1.2, "Parallel Connection for Designing Redundant Circuits".

### 3.1.2 Parallel Connection for Designing Redundant Circuits

#### Fields of Application

#### Increasing system availability

Redundant circuits are intended to supply systems, which have a high demand concerning operational reliability. If a fault occurs in the primary circuit of the first power supply unit, the second device automatically takes over the complete power supply without interruption, and vice versa.

For this purpose, the power supply units to be connected in parallel are designed large enough to enable the power supply of all loads using only one power supply unit.

#### Method of Operation

Two suitably designed power supply units from Phoenix Contact with identical functions are connected in parallel for simple redundancy. N-fold redundancy can be achieved by connecting n+1 devices in parallel (without additional power share cable).



No additional measures are required in redundancy operation as all one-phase power supply units of Phoenix Contact are internally protected in the primary circuit.

**SYS POWER SUPPLY UM E**

In order to operate the devices independently from a phase failure each single unit should be connected to a different phase, if possible (see Figure 3-7).

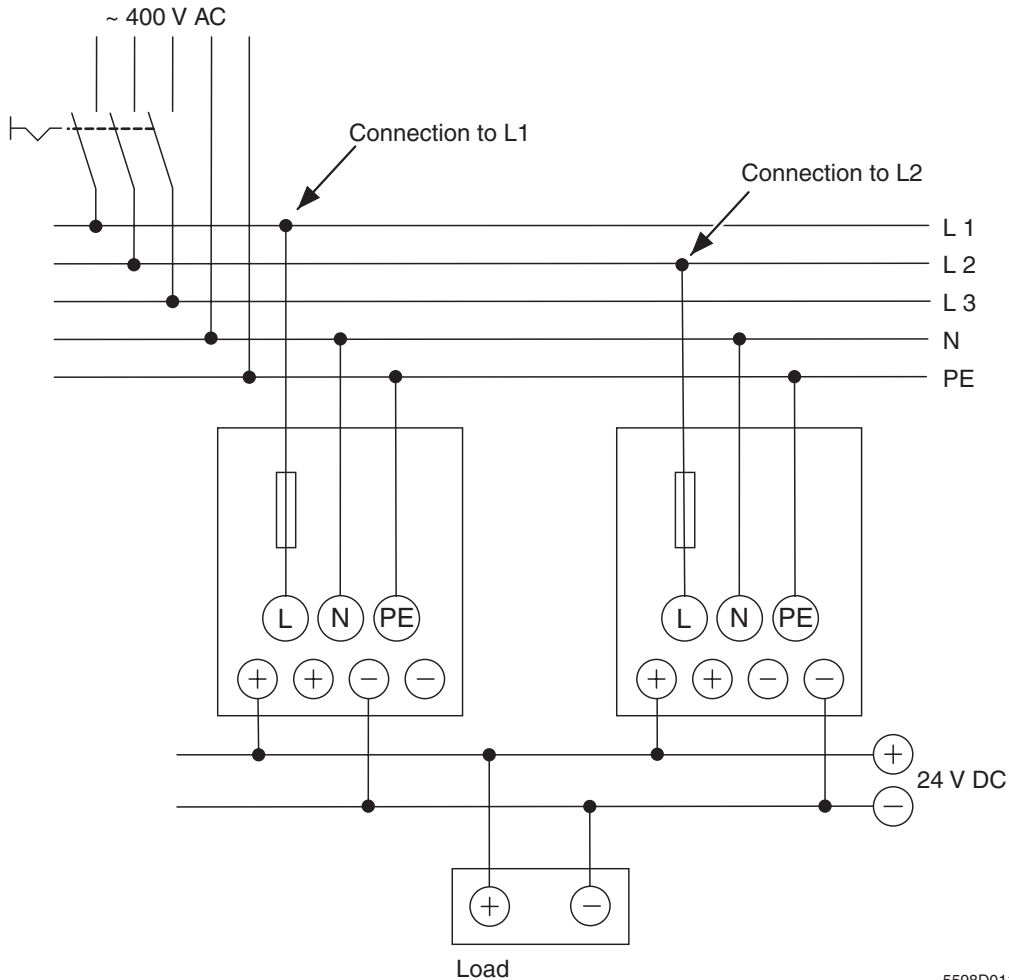

5598D011

Figure 3-7 One-phase redundancy operation

For three-phase devices with external protection, individual protection must be provided for each device.



To increase operational reliability all three-phase QUINT POWER power supply units also operate when a phase permanently fails. It must be noted that the devices have reduced mains buffering and the amount of harmonics in the primary circuit increases.

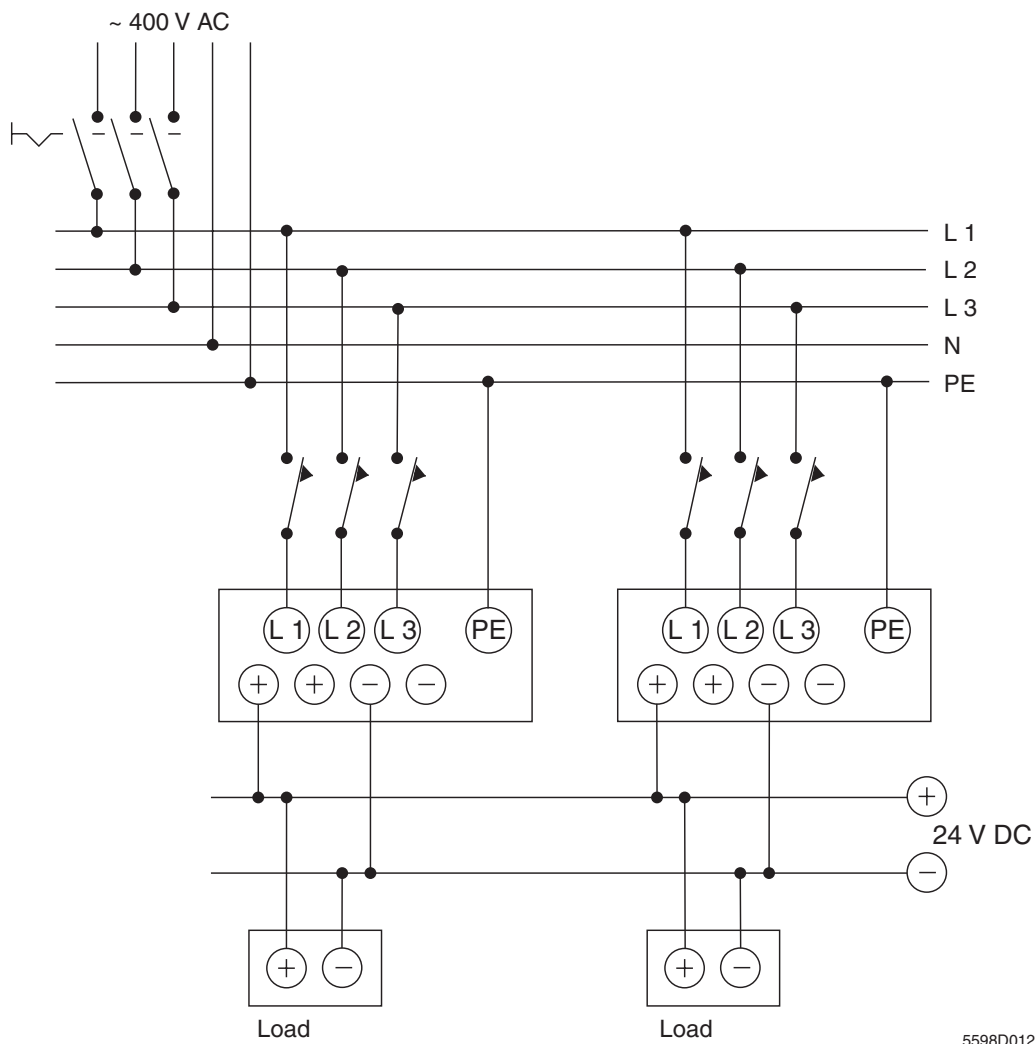

5598D012

Figure 3-8 Three-phase redundancy operation

## SYS POWER SUPPLY UM E

---

### **Output circuit decoupling diodes required for 100% redundancy**

All power supply units from Phoenix Contact, which can be connected in parallel, are dimensioned in such a way that an internal short circuit in the secondary circuit is virtually impossible. This means that for parallel connection of multiple power supply units no decoupling diodes are required in the output circuit. External diodes are only needed for a 100% redundancy and when more than two units are required.

The following example shows unnecessary power dissipation when using decoupling diodes:

A 40 A QUINT POWER power supply unit has an efficiency of 92% and a maximum power dissipation of 75 W at nominal load. There is a voltage drop across the decoupling diode of 1 V, approximately. The product of voltage and current results in a power dissipation of 40 W. The total power dissipation for the power supply unit with decoupling diode thus increases to 115 W, i.e., 53%. At the same time, the efficiency is reduced to 88%.

For redundant circuits monitoring of the individual power supply units is recommended in order to detect any failure.

### 3.2 Series Connection for Increasing Voltage (48 V DC)

#### Voltage doubling 48 V DC

Two devices designed for this purpose can be connected in series for voltage doubling (48 V DC).

All QUINT POWER power supply units from Phoenix Contact are designed for use in series connection. Only devices of the same performance class should be connected in series. STEP POWER and MINI POWER power supply units cannot be connected in series for increasing the voltage.

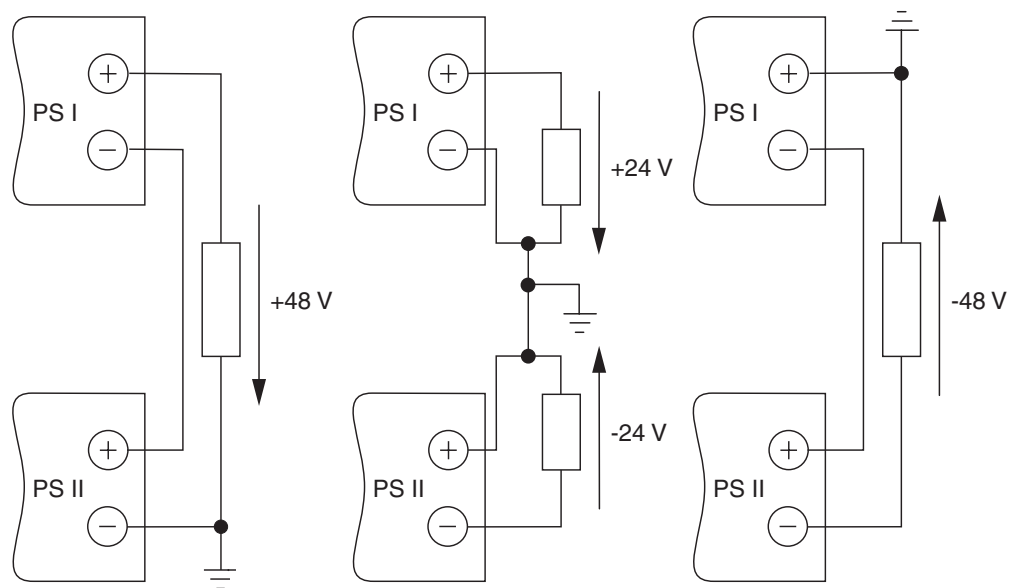

5598D013

Figure 3-9 Series connection

#### Fields of Application

QUINT POWER power supply units are always used when an output voltage of more than 24 V DC is required. An output voltage of 48 V can be provided if two 24 V power supply units are connected in series.

Depending on the specification of the PE connection output voltages of  $\pm 48$  V and  $\pm 24$  V DC can be provided.



Phoenix Contact offers QUINT POWER power supply units which can be connected as shown in Figure 3-9. No additional diodes are required for this circuit design.

### 3.3 Preventive Function Monitoring DC OK

The combination of function monitoring and early error detection is called "Preventive Function Monitoring" at Phoenix Contact. This technology allows reliable monitoring of the output voltage and early error detection on a load.

Function monitoring is designed as a separate electronic circuit in the power supply unit, which continuously monitors the output voltage set. Components of electrical systems are adequately supplied with power if the output voltage is more than 90% of the value set. Monitoring of the output voltage is carried out by means of a signaling threshold value. This value is set to 90% of the output voltage. For an output voltage of 24 V, for example, this value is 21.6 V. If a different output voltage value is set using the potentiometer, the signaling value is automatically adjusted.

A signal is indicated if the output voltage falls below the signaling threshold value. Table 3-1 shows, which signal output is available for which power supply unit. Remote monitoring of the power supply unit is possible using the active switching output and the electrically isolated contact.

Table 3-1 Signal outputs

Power Supply Unit	LED	Active DC OK Switching Output	Electrically Isolated Relay Contact
		Switching Voltage 24 V DC, Short-Circuit-Proof	30 V AC/DC max., 1 A
QUINT POWER	Yes	Yes	Yes
MINI POWER	Yes	Yes	
STEP POWER	Yes		

**Useful Information from Everyday Practice**

Figure 3-10 shows the curve of the voltage  $U$  over the time  $t$ . The output voltage is above 90% of the value set. This state is indicated by the LED, which is permanently on, by a 24 V DC voltage level of at the switching output and by the relay contact closed.

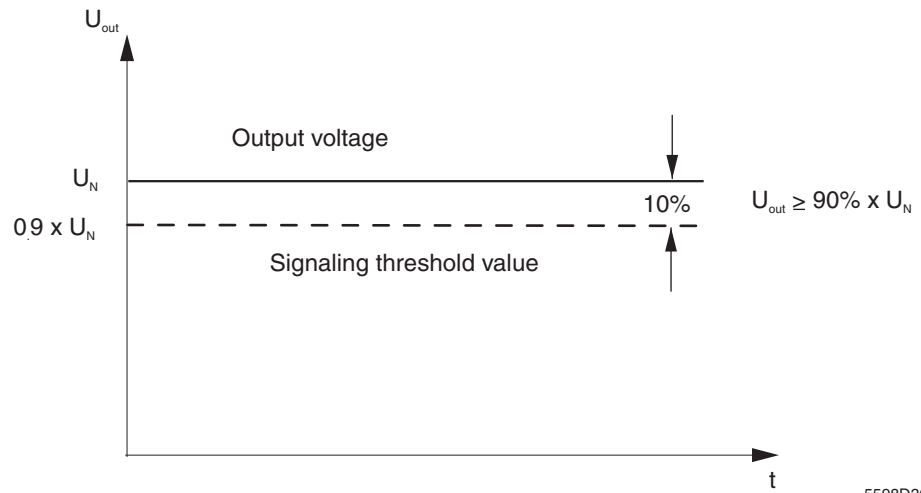

Figure 3-10 Output voltage OK

- Relay contact closed
- 24 V switching output
- LED ON

## SYS POWER SUPPLY UM E

Figure 3-11 shows the curve of the voltage  $U$  over the time  $t$ . Point  $t_1$  indicates the falling of the output voltage below the signaling threshold value. This state is indicated by a flashing LED, a 0 V voltage level at the switching output and the relay contact opened.

A load error often causes the output voltage to fall down. Short circuit and overload are typical errors. Function monitoring not only monitors the output voltage but also the connected loads.

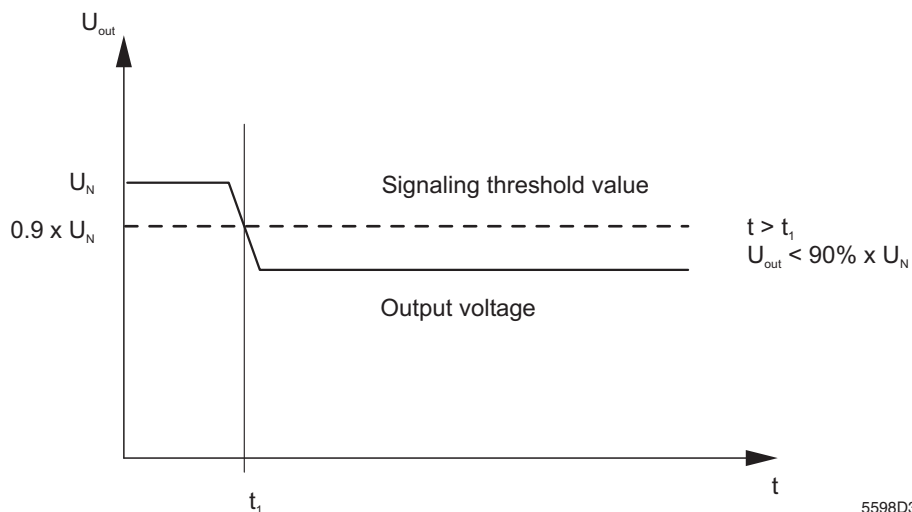

5598D304

Figure 3-11 Output voltage not OK

- Relay contact opened
- 0 V switching output
- LED flashing

Useful Information from Everyday Practice

Figure 3-12 and Figure 3-13 show the possible signal output circuits for evaluation using signal indicators. Both signal outputs can also be directly read by a higher-level control system, e.g., PLC.

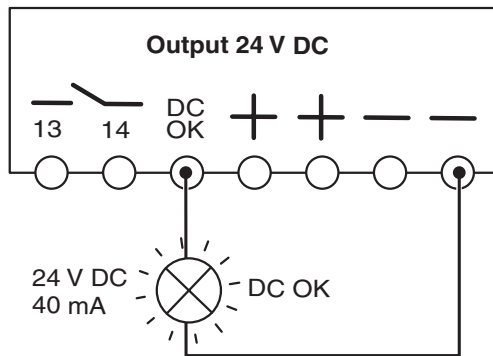

5598D302

Figure 3-12 DC OK switching output

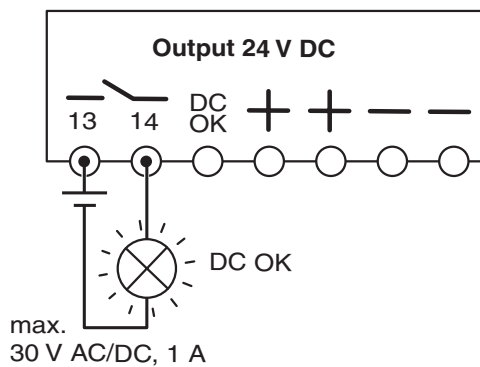

5598D303

Figure 3-13 Electrically isolated contact

## SYS POWER SUPPLY UM E

### Early error detection

Power supply units with function monitoring are always used if maximum system availability and minimum downtimes are important. Load errors, which may lead to power supply unit overload, can often only hardly be localized. In the worst case, they cannot be localized at all. On a long-term view, this can lead to expensive system downtimes, which are difficult to maintain. The solution is an early error detection called preventive function monitoring.

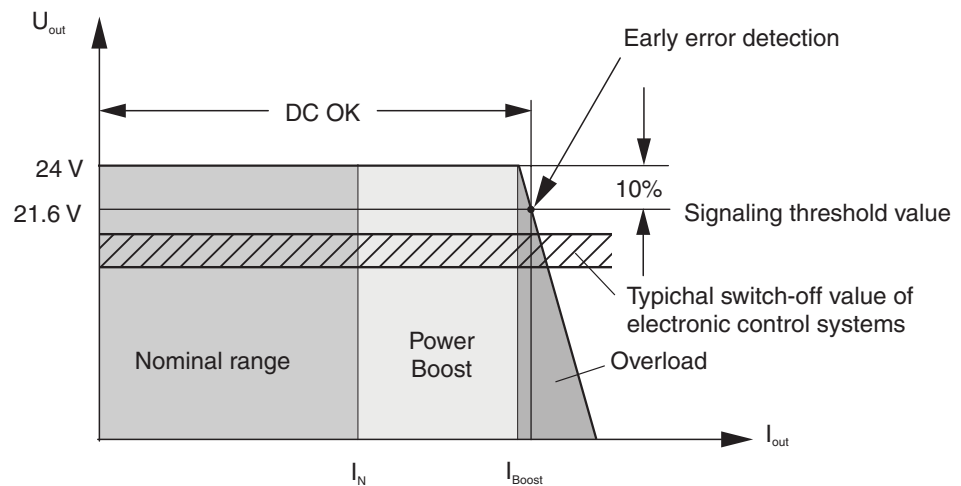

5598D305

Figure 3-14 Early error detection with power boost and DC OK

Figure 3-14 shows the U/I characteristic curve of a power supply unit with power boost and preventive function monitoring. If the power boost is fully consumed the overload of the power supply unit caused by the load results in the output voltage falling down.

Overload may occur slowly or sporadically if, for example, the power consumption of solenoid valves increases due to more and more dirt on the valves. Incorrect system expansion leads to permanent overload of the power supply unit.

A signal is indicated if the output voltage falls below the signaling threshold value. The lower voltage value for typical loads, e.g., PLC, is between 18 V and 20 V. When the signaling threshold value is reached (e.g., 21.6 V for an output voltage of 24 V) the PLC is still supplied with adequate voltage. Evaluation of the signal outputs helps to respond to load errors early and prevent a total system failure.

## Useful Information from Everyday Practice

**Signaling in parallel operation**

System availability is additionally increased if two power supply units are connected in parallel for redundancy reasons. Remote monitoring is recommended for each power supply unit in order to immediately detect a device failure and to keep the redundancy at any point of time.

Multiple power supply units can either be monitored individually or using a common signal. As shown in Figure 3-15 a loop connects the active switching output of the first device and the electrically isolated contacts of further devices.

For function monitoring the signal output is isolated from the power output. "Reverse supply" by a power supply unit to the "DC OK" output of the power supply units connected in parallel is not possible. A clear function signal is generated at any point of time.

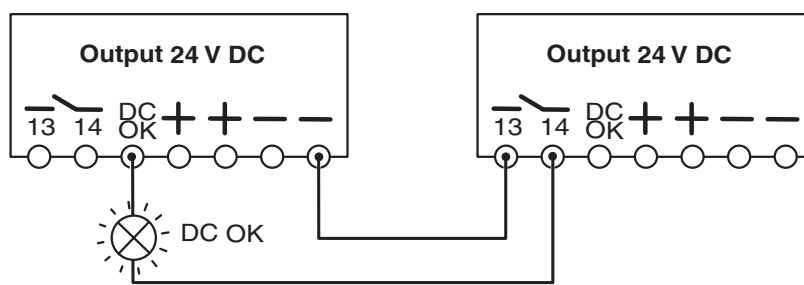

5598D306

Figure 3-15 Monitoring multiple power supply units using only one signal

## SYS POWER SUPPLY UM E

The following tables give you an overview of the signal meanings:

Table 3-2 QUINT POWER

Green "DC OK" LED	LED ON	LED Flashing	LED OFF
<b>Transistor switching output</b>	U = 24 V	U = 0 V	U = 0 V
<b>Electrically isolated contact</b>	Closed	Opened	Opened
<b>Meaning</b>	Output voltage above 90% of the voltage set	Output voltage below 90% of the voltage set	No voltage at the output
<b>State description</b>	<ul style="list-style-type: none"> <li>– QUINT POWER operational</li> <li>– Output voltage and output current OK</li> </ul>	<ul style="list-style-type: none"> <li>– QUINT POWER operational</li> <li>– Load error</li> <li>– Current consumption is higher than <math>I_{BOOST}</math></li> <li>– Output short-circuited</li> </ul>	<ul style="list-style-type: none"> <li>– QUINT POWER out of service</li> <li>– No line voltage present</li> <li>– Fuse blown in primary circuit</li> <li>– QUINT POWER faulty</li> </ul>
<b>Remedy</b>		<ul style="list-style-type: none"> <li>– Remove load error</li> <li>– Use more powerful QUINT POWER</li> <li>– Connect QUINT POWER of the same type in parallel to the existing device</li> <li>– Remove short circuit</li> </ul>	<ul style="list-style-type: none"> <li>– Apply line voltage</li> <li>– Reactivate fuse</li> <li>– Replace QUINT POWER, if required</li> </ul>

Table 3-3 MINI POWER

Green "DC OK" LED	LED ON	LED OFF
<b>Transistor switching output (only for MINI 24 V DC)</b>	U = 24 V	U = 0 V
<b>Meaning</b>	Output voltage greater than 21.6 V	Output voltage lower than 21.6 V
<b>State description</b>	<ul style="list-style-type: none"> <li>– MINI POWER operational</li> <li>– Output voltage and output current OK</li> </ul>	<ul style="list-style-type: none"> <li>– Load error</li> <li>– MINI POWER out of service</li> <li>– Output current is higher than <math>I_{BOOST}</math></li> <li>– Output short-circuited</li> <li>– No line voltage present</li> <li>– Fuse blown in primary circuit</li> <li>– MINI POWER faulty</li> </ul>
<b>Remedy</b>		<ul style="list-style-type: none"> <li>– Remove load error</li> <li>– Connect MINI POWER of the same type in parallel to the existing device</li> <li>– Apply line voltage, reactivate fuse, or replace MINI POWER, if required</li> </ul>

## Useful Information from Everyday Practice

Table 3-4 STEP POWER

Green "POWER" LED	LED ON	LED ON	LED OFF
Red "OVERLOAD" LED	LED OFF	LED ON	LED OFF
<b>Meaning</b>	<ul style="list-style-type: none"> <li>- STEP POWER operational</li> <li>- Output voltage OK</li> </ul>	<ul style="list-style-type: none"> <li>- Load error</li> <li>- STEP POWER operational</li> <li>- Thermally or electrically overloaded</li> </ul>	<ul style="list-style-type: none"> <li>- STEP POWER out of service</li> <li>- No line voltage present</li> <li>- Fuse blown in primary circuit</li> <li>- STEP POWER faulty</li> </ul>
<b>Remedy</b>		<ul style="list-style-type: none"> <li>- Remove load error</li> <li>- Connect STEP POWER of the same type in parallel to the existing device</li> <li>- Reset STEP POWER by shortly disconnecting the line voltage or the load</li> </ul>	<ul style="list-style-type: none"> <li>- Apply line voltage</li> <li>- Reactivate fuse</li> <li>- Replace STEP POWER, if required</li> </ul>

### 3.4 Adjustability of the Output Voltage

**Adjustment range:**  
+22.5 V DC to +28.5 V DC

Phoenix Contact offers power supply units with either fixed voltage output or adjustable voltage output.

QUINT POWER power supply units have a nominal output voltage of 24 V. This voltage can be freely adjusted in the range from 22.5 V to 28.5 V. By default, these devices are set to a voltage of exactly 24 V DC.

#### Fields of Application

The adjustable outputs allow for compensation of voltage drops in connected cables for spatially distributed systems. Adjusting the charging voltage also enables charging lead-gel accumulators.

**Compensating power dissipation**

Power dissipation in the supply cable for the secondary circuit increases linearly with increasing current and cable length. Table 3-5 shows the voltage losses in function of the cable cross section and the output current. For the calculation of the voltage losses also see section 3.9, "Layout of 24 V DC Supply Cables (Cable Cross Section)".



If the default 24 V DC setting has been adjusted for devices, which are to be connected in parallel, it is strictly necessary to carry out a balancing procedure as described in section 3.1, "Parallel Connection".

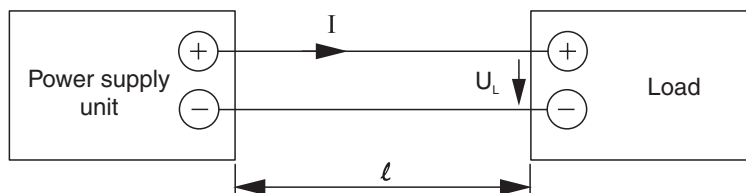

5598D024

Figure 3-16 Cable length

#### Explanation of the Tables:

Table 3-5 shows the on-load voltages  $U_L$  for an output voltage of 24 V and 28.5 V. The first line indicates the nominal output voltage of the power supply unit. Lines 3 to 8 indicate the cable lengths in meters. The cable path from the power supply unit to the load has been taken into account.

## Useful Information from Everyday Practice

Table 3-5 On-load voltage  $U_L$  as a function of the output current  $I$  and the cable length  $l$  for copper cables with a cross section of  $1.5 \text{ mm}^2$  (16 AWG)

$l \backslash I$	2.5 A		5 A		10 A		20 A		30 A		40 A	
0 m	<b>24.0 V</b>	<b>28.5 V</b>	<b>24.0 V</b>	<b>28.5 V</b>	<b>24.0 V</b>	<b>28.5 V</b>	<b>24.0 V</b>	<b>28.5 V</b>	<b>24.0 V</b>	<b>28.5 V</b>	<b>24.0 V</b>	<b>28.5 V</b>
10 m (33 ft.)	23.42	27.92	22.83	27.33	21.66	26.16	19.32	23.82	16.98	21.48	14.64	19.14
20 m (66 ft.)	22.83	27.33	21.66	26.16	19.32	23.82	14.64	19.14	9.96	14.46	5.29	9.79
30 m (98 ft.)	22.25	26.75	20.49	24.99	16.98	21.48	9.96	14.46	2.95	7.45	0.00	0.43
40 m (131 ft.)	21.66	26.16	19.32	23.82	14.64	19.14	5.29	9.79	0.00	0.43	0.00	0.00
50 m (164 ft.)	21.08	25.58	18.15	22.65	12.30	16.80	0.61	5.11	0.00	0.00	0.00	0.00
60 m (197 ft.)	20.49	24.99	16.98	21.48	9.96	14.46	0.00	0.43	0.00	0.00	0.00	0.00

Table 3-6 On-load voltage  $U_L$  as a function of the output current  $I$  and the cable length  $l$  for copper cables with a cross section of  $2.5 \text{ mm}^2$  (14 AWG)

$l \backslash I$	2.5 A		5 A		10 A		20 A		30 A		40 A	
0 m	<b>24.0 V</b>	<b>28.5 V</b>	<b>24.0 V</b>	<b>28.5 V</b>	<b>24.0 V</b>	<b>28.5 V</b>	<b>24.0 V</b>	<b>28.5 V</b>	<b>24.0 V</b>	<b>28.5 V</b>	<b>24.0 V</b>	<b>28.5 V</b>
10 m (33 ft.)	23.65	28.15	23.30	27.80	22.60	27.10	21.19	25.69	19.79	24.29	18.39	22.89
20 m (66 ft.)	23.30	27.80	22.60	27.10	21.19	25.69	18.39	22.89	15.58	20.08	12.77	17.27
30 m (98 ft.)	22.95	27.45	21.89	26.39	19.79	24.29	15.58	20.08	11.37	15.87	7.16	11.66
40 m (131 ft.)	22.60	27.10	21.19	25.69	18.39	22.89	12.77	17.27	7.16	11.66	1.54	6.04
50 m (164 ft.)	22.25	26.75	20.49	24.99	16.98	21.48	9.96	14.46	2.95	7.45	0.00	0.43
60 m (197 ft.)	21.89	26.39	19.79	24.29	15.58	20.08	7.16	11.66	0.00	3.24	0.00	0.00

Table 3-7 On-load voltage  $U_L$  as a function of the output current  $I$  and the cable length  $l$  for copper cables with a cross section of  $4 \text{ mm}^2$  (12 AWG)

$l \backslash I$	10 A		20 A		30 A		40 A	
0 m	<b>24.0 V</b>	<b>28.5 V</b>	<b>24.0 V</b>	<b>28.5 V</b>	<b>24.0 V</b>	<b>28.5 V</b>	<b>24.0 V</b>	<b>28.5 V</b>
10 m (33 ft.)	23.12	27.62	22.25	26.75	21.37	25.87	20.49	24.99
20 m (66 ft.)	22.25	26.75	20.49	24.99	18.74	23.24	16.98	21.48
30 m (98 ft.)	21.37	25.87	18.74	23.24	16.11	20.61	13.47	17.97
40 m (131 ft.)	20.49	24.99	16.98	21.48	13.47	17.97	9.96	14.46
50 m (164 ft.)	19.61	24.11	15.23	19.73	10.84	15.34	6.46	10.96
60 m (197 ft.)	18.74	23.24	13.74	17.97	8.21	12.71	2.95	7.45

## SYS POWER SUPPLY UM E

Table 3-8 On-load voltage  $U_L$  as a function of the output current  $I$  and the cable length  $l$  for copper cables with a cross section of  $6 \text{ mm}^2$  (10 AWG)

$l \backslash I$	30 A		40 A	
0 m	24.0 V	28.5 V	24.0 V	28.5 V
10 m (33 ft.)	22.25	26.75	21.66	26.16
20 m (66 ft.)	20.49	24.99	19.32	23.82
30 m (98 ft.)	18.74	23.24	16.98	21.48
40 m (131 ft.)	16.98	21.48	14.64	19.14
50 m (164 ft.)	15.23	19.73	12.30	16.80
60 m (197 ft.)	13.47	17.97	9.96	14.46

Table 3-9 On-load voltage  $U_L$  as a function of the output current  $I$  and the cable length  $l$  for copper cables with a cross section of  $10 \text{ mm}^2$  (8 AWG)

$l \backslash I$	30 A		40 A	
0 m	24.0 V	28.5 V	24.0 V	28.5 V
10 m (33 ft.)	22.95	27.45	22.60	27.10
20 m (66 ft.)	21.89	26.39	21.19	25.69
30 m (98 ft.)	20.84	25.34	19.79	24.29
40 m (131 ft.)	19.79	24.29	18.39	22.89
50 m (164 ft.)	18.74	23.24	16.98	21.48
60 m (197 ft.)	17.68	22.18	15.58	20.08

### Example

A power supply unit with a nominal output current of  $I = 10 \text{ A}$  supplies a load with an input voltage of  $U_L = 23.0 \text{ V DC}$  via a copper cable with a cross section of  $4 \text{ mm}^2$  (12 AWG).

1. Table 3-7 shows the cable cross section of  $4 \text{ mm}^2$  (12 AWG).
2. A power supply unit with a nominal current of  $10 \text{ A}$  is shown in the second and third columns.

### Solution

If the power supply unit is set to  $24 \text{ V}$ , the supply voltage across the load is above  $23 \text{ V}$  for a cable length of up to  $10 \text{ m}$  (33 ft.). If the output voltage of the power supply unit is set to  $28.5 \text{ V}$ , the voltage across the load is above  $23 \text{ V}$  for a cable length of up to  $60 \text{ m}$  (197 ft.).

Table 3-7 makes clear that central power supply over greater distances very quickly leads to large cable cross sections or high losses. Both dramatically increases installation and operating costs.

### Positioning power supply units close to the load center

The best technical and most cost-effective solution is to use several distributed power supply units, each positioned close to the load center.

Power supply units, which have a low overall depth, are particularly suitable for distributed control boxes. QUINT POWER power supply units from Phoenix Contact fulfill these requirements.

### 3.5 Wide-Range Input

All QUINT POWER, MINI POWER and STEP POWER power supply units are equipped with a wide-range input. Therefore, all one-phase power supply units can be operated on line voltages from 85 to 264 V AC and all three-phase power supply units on line voltages from 320 to 575 V AC. These voltage ranges cover the most important supply networks worldwide.

Compared to devices with a fixed voltage input, devices with wide-range input have the following advantages:

- Systems may be tested at any production location and may be operated anywhere in the world without erroneous switching over of the input voltage.
- Wide-range inputs ensure reliable functioning of the power supply units even in the event of high voltage fluctuations caused by instable supply networks.
- Using power supply units with wide-range inputs reduces storage and logistics because for one performance class only one device is required, independent of the input voltage.

When selecting a power supply unit it must be considered that the term "wide-range input" is not always used clearly. Automatic switching over of the input voltage ranges ("Auto Range"), for example, is incorrectly used for wide range.

Auto-range devices detect the applied input voltage and switch over internally between the different input voltage ranges. Operation between these defined input ranges, e.g., in the event of voltage fluctuations, is not reliable.

### 3.6 Connection to Different Network Configurations

Figure 3-17 shows the connection of a one-phase power supply unit to different network configurations.

Network configurations:

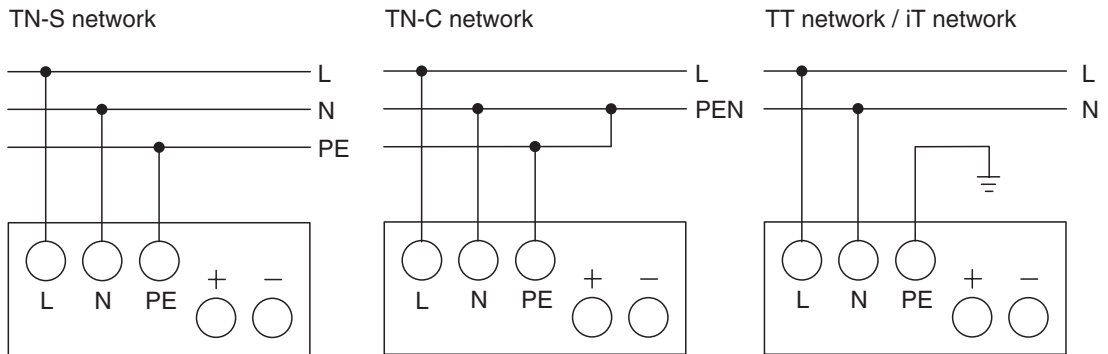

5598D015

Figure 3-17 Connection of a one-phase power supply unit

Useful Information from Everyday Practice

The following graphics show the connection of a three-phase power supply unit to different network configurations.

Network configurations:

TN-S network

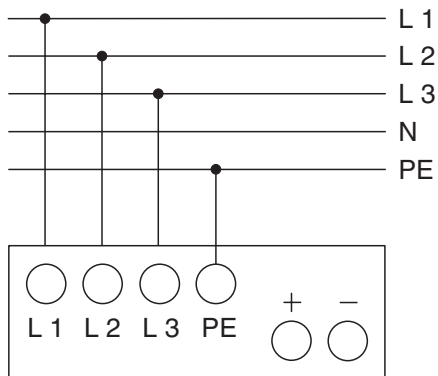

TN-C network

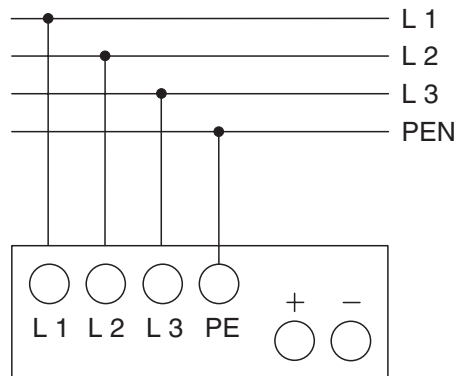

TT network

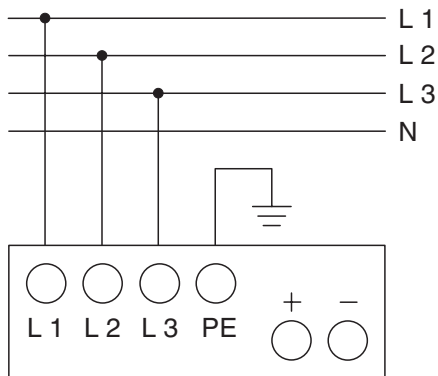

iT network

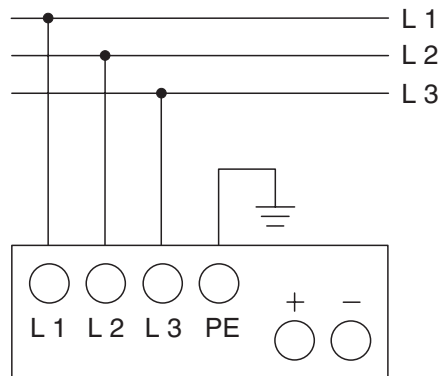

5598D016

Figure 3-18 Connection of a three-phase power supply unit

**SYS POWER SUPPLY UM E**

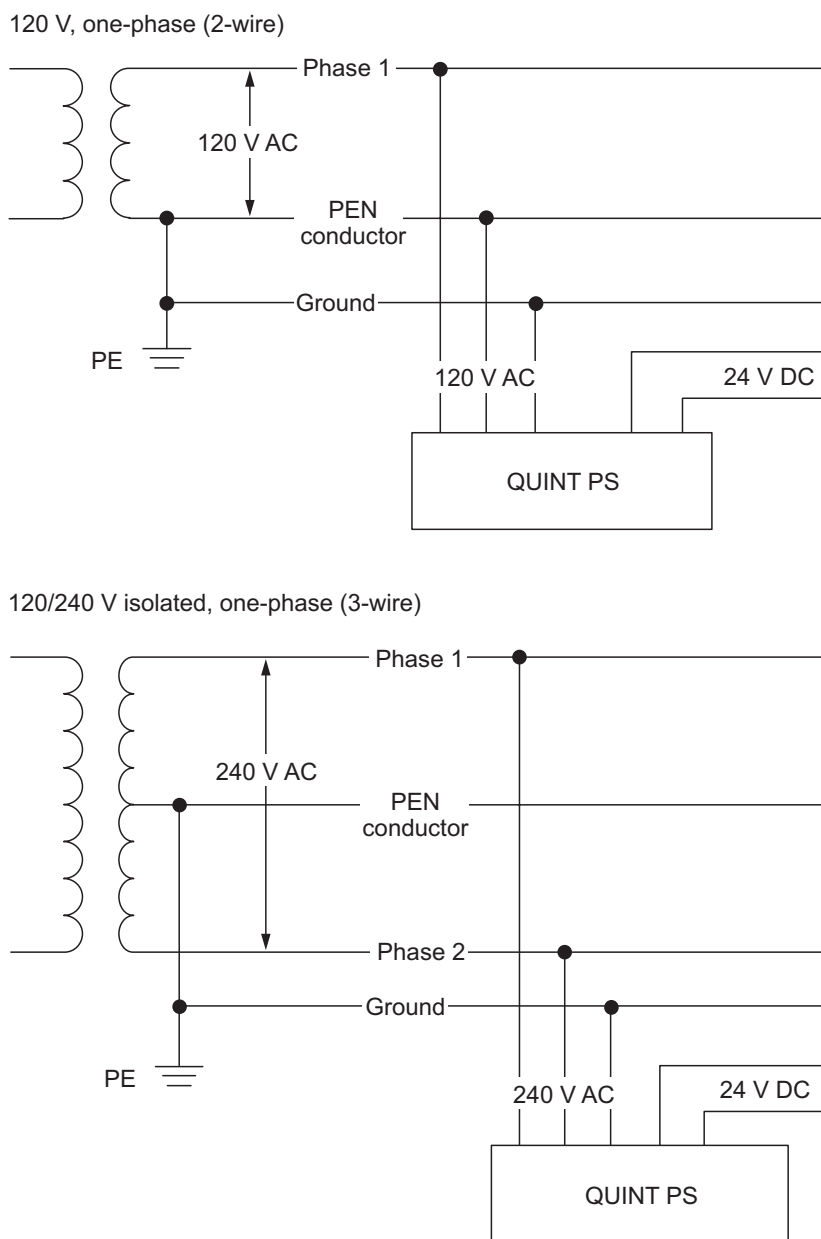

5598D321

Figure 3-19 US network configurations (one-phase)

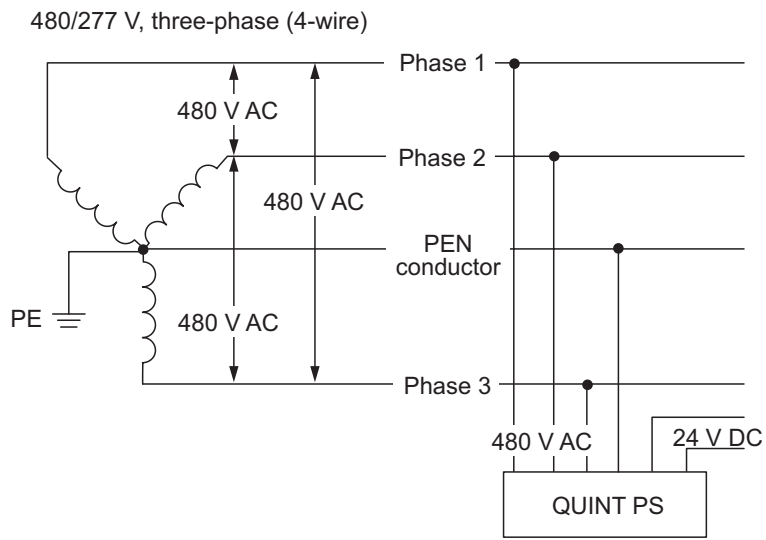

5598D322

Figure 3-20 US network configurations (three-phase)



Phoenix Contact power supply units are suitable for connection to all network configurations shown above.

### 3.7 Selective Protection by Means of Fusing in the Secondary Circuit

High-quality power supply units are electronically protected against short circuit and overload. For device protection external fuses in the secondary circuit are thus not required for these power supply units.

#### Protecting current paths individually

If the output current of a central 24 V power supply is distributed onto several loads, it is recommended to protect each current path individually. In this way only the assigned fuse blows in the event of a load failure. All remaining loads are still supplied with electrical energy. In practice, the output current of a power supply unit is mainly distributed for powerful power supply units. Maximum short-circuit current is of decisive importance to reliable blowing of the fuse.

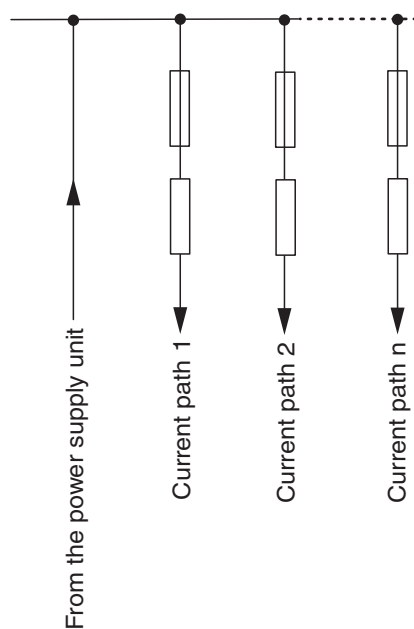

5598D029

Figure 3-21 Selective protection

---

**Useful Information from Everyday Practice**

---

<b>Unregulated</b>	Unregulated power supply units provide the highest short-circuit current. The maximum short-circuit current of these devices is only limited by the fuse at the device output and can typically be ten times the nominal output current for a short period.
<b>Linearly regulated</b>	With linearly regulated devices, the short-circuit current is limited by the output fuse and the controller temperature and can be two to three times the nominal current for a short period.
<b>Primary-switched mode</b>	<p>Many of the primary-switched mode power supply units available operate according to the fold-back characteristic curve. In order to avoid high component temperatures they switch off in the event of an overload or a load short circuit and attempt to start again after a short time. The short circuit current is about 1.1 times the nominal current <math>I_{nom}</math>. The power supply unit continues to operate normally as soon as the overload or short circuit have been removed (see section 3.15, "Output Characteristic Curves of Power Supply Units").</p> <p>In order to guarantee system selectivity at any time the blowing of the fuses used must occur earlier than the switching off of the power supply unit. If not, the erroneous path is not enabled and the short circuit will remain. The power supply unit permanently tries to carry out an unsuccessful warm start and changes to clock operation.</p> <p>As a result, the supply of all the loads connected in the system will be interrupted. The faulty load can only hardly be localized because no fuse has blown. This leads to long downtimes and unnecessary costs.</p> <p>Fuse blowing depends on the <math>I^2t</math> value (pre-arcing) of the fuse. The higher the short-circuit current the more reliable the fuse blowing. Reliable solutions can thus be implemented using power supply units, which do not switch off in the event of an overload or a load short circuit but permanently supply output current. These power supply units operate according to the U/I characteristic.</p> <p>When selecting miniature circuit breakers, modules with low internal resistance must be used. Using thermomagnetic circuit breakers (TMC), which have a low internal resistance, is recommended. Cable cross sections should also be chosen large enough. It must be noted that cable resistance increases with reduced cable cross section. Too high cable resistance causes too high cable losses. According to Ohm's law, the maximum current is therefore not able to flow. However, the maximum current is required for reliable fuse blowing.</p> <p>All QUINT POWER and MINI POWER power supply units from Phoenix Contact are being provided with a U/I-controlled characteristic.</p>

## SYS POWER SUPPLY UM E

**Secondary-circuit fusing** When using secondary miniature circuit breakers/fuses the question arises what type to use. Table 3-10 shows, which circuit breaker/fuse is activated by which power supply unit. In the shown combinations the miniature circuit breaker/fuse is activated by means of the magnetic portion of the protection characteristic.

Table 3-10 Secondary circuit breakers/fuses

Type	Circuit Breaker						TMC								NEOZED			
	B		C				F1 (Fast-Blow)				M (Medium-Blow)							
	6 A	10 A	2 A	4 A	6 A	10 A	2 A	4 A	6 A	10 A	2 A	4 A	6 A	10 A	2 A	4 A	6 A	10 A
QUINT 2.5 A one-phase							X	X										
QUINT 5 A one-phase			X	X*			X	X	X	X	X				X			
QUINT 5 A three-phase			X	X*			X	X	X	X	X				X			
QUINT 10 A one-phase	X		X	X*	X*		X	X	X	X	X	X*	X*		X	X*		
QUINT 10 A three-phase	X		X	X*	X*		X	X	X	X	X	X*	X*		X	X*		
QUINT 20 A one-phase	X	X	X	X	X	X*	X	X	X	X	X	X	X*	X*	X	X	X	
QUINT 40 A one-phase	X	X	X	X	X	X*	X	X	X	X	X	X	X*	X*	X	X	X	
QUINT 20 A three-phase	X	X	X	X	X	X*	X	X	X	X	X	X	X*	X*	X	X	X	
QUINT 30 A three-phase	X	X	X	X	X	X*	X	X	X	X	X	X	X*	X*	X	X	X	X*
QUINT 40 A three-phase	X	X	X	X	X	X*	X	X	X	X	X	X	X	X*	X	X	X	X*

\* In this combination, the power supply unit activates the circuit breaker/fuse by means of the thermal portion of the protection characteristic.

For measuring the blowing times a test set-up according to the standard has been used. The testing and ambient conditions are based on DIN VDE 0641 Part 11.

The warm-up phase of the power supply unit is more than 60 s, the cooling phase of the TMC more than 60 s. The base load is 0.5 times  $I_N$ , and the ambient temperature is 20°C to 25°C (68°F to 77°F) according to Section 8.2. The cable length (terminal to terminal) in the secondary circuit is 1 m (3 ft.) according to Section 8.2, the cable cross section is 1.5 mm<sup>2</sup> (16 AWG).

### 3.8 Layout of External Primary-Circuit Fusing

All one-phase power supply units from Phoenix Contact are provided with internal fuses in the primary circuit. If the fuse blows there probably is a device fault. In this case, the device must be sent back to and checked by Phoenix Contact.

The primary circuits of three-phase QUINT POWER power supply units are protected externally using three-phase thermomagnetic circuit breakers. For protection, either 6 A, 10 A or 16 A circuit breakers (characteristic B) can be used.



The three-phase circuit breakers must not be coupled mechanically. Two-phase operation is permanently possible without restrictions.

It must be noted that the devices have reduced mains buffering and the amount of harmonics is increased.

It is recommended to provide circuit breakers in the primary circuit for each power supply unit. Device installation must be carried out according to the regulations in EN 60950. It must be possible to switch the device when the power is switched off using an appropriate external disconnecting device. For this, primary-circuit line protection, for example, is suitable.

### 3.9 Layout of 24 V DC Supply Cables (Cable Cross Section)

Cables are designed according to VDE 0100 Part 523 (current carrying capacity of conductors and cables). The following current carrying capacities for isolated multi-wire cables are permitted:

Table 3-11 Cable cross sections

Nominal cross section Cu in mm <sup>2</sup>	1.5	2.5	4	6	10	16
Current carrying capacity in A	18	26	34	44	61	82

The following formula is used for rating the 24 V DC cable:

$$A = \frac{200 \cdot P}{u \cdot U^2 \cdot \kappa} \cdot \ell \quad [1]$$

$$\Rightarrow u[\%] = \frac{200 \cdot P}{U^2 \cdot \kappa \cdot A} \cdot \ell \quad [2]$$

Where

- A = Cross section in mm<sup>2</sup>
- $\ell$  = single cable length in m

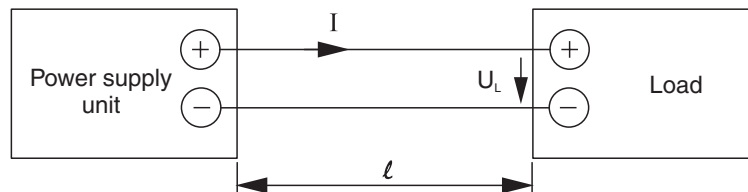

5598D024

Figure 3-22 Cable length

- U = voltage in Volts
- P = load power in Watts
- u = voltage drop in %
- $\kappa$  = conductivity in m/ $\Omega$  mm<sup>2</sup>  
Copper 57 m/ $\Omega$  mm<sup>2</sup>  
Aluminum 36 m/ $\Omega$  mm<sup>2</sup>

## Useful Information from Everyday Practice

**Example**

A power supply unit with the output values  $I_a = 5 \text{ A}$  and  $U_a = 24 \text{ V}$  supplies a load, which is connected to it via a 5 m (16 ft.) copper cable with a cross section of  $A = 2.5 \text{ mm}^2$  (14 AWG).

How high is the voltage  $U_L$  across the load?

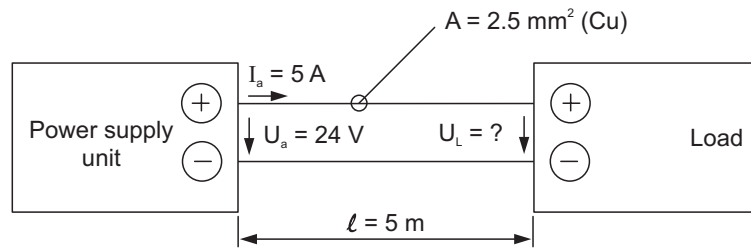

5598D026

Figure 3-23 Voltage across the load

According to formula [2] there is (with  $P = U \cdot I$ ):

$$u[\%] = \frac{200 \cdot 24 \text{ V} \cdot 5 \text{ A}}{(24 \text{ V})^2 \cdot 57 \frac{\text{m}}{\Omega \text{mm}^2} \cdot 2.5 \text{ mm}^2} \cdot 5 \text{ m} = 1.5\%$$

The output voltage  $U_A = 24 \text{ V}$  falls by 1.5% to  $U_L = 23.64 \text{ V}$ .

### 3.10 Rating of the AC Low Voltage Supply Line

For one-phase systems (with  $p = U \cdot I \cdot \cos \varphi$ ) according to formula [2] there is:

$$1 \sim u [\%] = \frac{200 \cdot p}{U^2 \cdot \kappa \cdot A} \cdot \ell = \frac{200 \cdot I \cdot \cos \varphi}{U \cdot \kappa \cdot A} \cdot \ell \quad [3]$$

For three-phase systems (with  $p = \sqrt{3} U \cdot I \cdot \cos \varphi$ ) according to formula [2] there is:

$$3 \sim u [\%] = \frac{100 \cdot p}{U^2 \cdot \kappa \cdot A} = \frac{100 \cdot \sqrt{3} \cdot I \cdot \cos \varphi}{U \cdot \kappa \cdot A} \cdot \ell \quad [4]$$

All formulaic symbols are defined in section 3.9, "Layout of 24 V DC Supply Cables (Cable Cross Section)".

$\cos \varphi$  = power factor of the power supply unit

#### Example

A three-phase QUINT POWER 20 A / 3 · 400V power supply unit is connected to a free output of a distribution box via a 75 m (246 ft.) copper cable with  $A = 2.5 \text{ mm}^2$  (14 AWG). A voltage of  $U_{L\Delta} = 3 \cdot 400 \text{ V AC}$  is measured at the distribution box.

How high is the AC voltage at the input of the power supply unit?

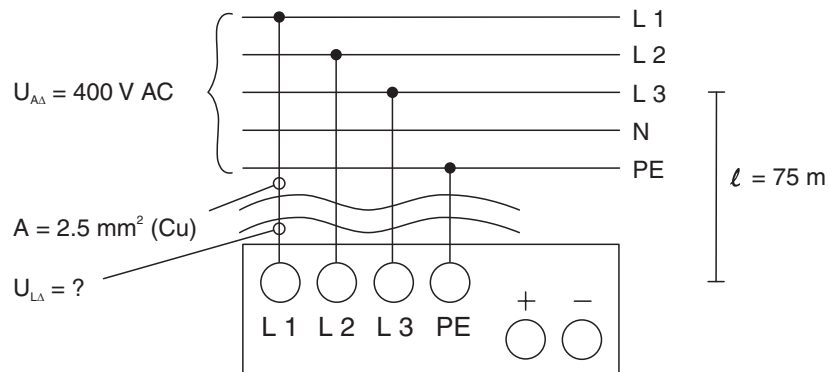

5598D027

Figure 3-24 TN-S network

According to formula [4] there is:

$$3 \sim u [\%] = \frac{100 \cdot \sqrt{3} \cdot 1.4 \text{ A} \cdot 0.7}{400 \text{ V} \cdot 2.5 \text{ mm}^2 \cdot 57 \frac{\text{m}}{\Omega \text{mm}^2}} \cdot 75 \text{ m} = 0.22\%$$

The AC input voltage across the power supply unit is

$$U_{L\Delta} = 3 \cdot 400 \text{ V} \cdot (1 - 0.0022) = 3 \cdot 399.2 \text{ V}.$$

### 3.11 Questions on EMC

#### **ElectroMagnetic Compatibility**

The major EMC standards ((E)lectro(M)agnetic C(ompatibility)) for EU conformity of compact power supply units are listed in the following table.

In general, power supply units, which are provided with the CE conformity mark, must not interfere with other devices in an unauthorized manner and must not be interfered with in their function in an unauthorized manner by other devices. Noise emission is described in the European standard EN 61000-6-3, noise immunity is defined in EN 61000-6-2.

Noise emission is divided into two classes: domestic sector (Part 1) and industrial sector (Part 2). The domestic sector comprises all loads, which are connected to the public medium voltage transformer. The industrial sector comprises all loads, which are connected to the non-public medium voltage transformer.

Table 3-12 Major standards

	<b>Part 1: Domestic, Office and Commercial Sector</b>	<b>Part 2: Industrial Sector</b>
	Noise Emission According to EN 61000-6-3	
<b>Housing</b>	EN 60715, Class B	EN 55011, Class A
<b>AC line supply current</b>	EN 60715, Class B	EN 55011, Class A
<b>Limit values for harmonic currents</b>	EN 61000-3-2	
<b>Limit values for voltage fluctuations (flicker)</b>	EN 61000-3-3	
	Noise Immunity According to EN 61000-6-2	
<b>Electrostatic discharge (ESD)</b>	EN 61000-4-2	
<b>Electromagnetic HF field</b>	EN 61000-4-3	
<b>Fast transients (burst)</b>	EN 61000-4-4	
<b>Surge current load</b>	EN 61000-4-5	
<b>Conducted interference</b>	EN 61000-4-6	
<b>Voltage fluctuations</b>	EN 61000-4-11	

#### **EN 61000-6-2**

For complying with the basic EMC standard EN 6100-6-2 a power supply unit must for example have effective protective equipment against noise, e.g. lightning, burst, surge or electrostatic discharge in the range of more than one kV.

#### **Burst**

Low-energy but quickly recurring (transient) interferences are known as "burst". These interferences occur in welding systems but they are also caused by lightning strikes close to electrical lines. The lightning bolt must not even directly strike the line. Inducing electromagnetic fields in the lines will already lead to a voltage discharge.

#### **Surge**

High-energy and transient interferences are known as "surge". They occur in the form of surge current loads, e.g., in the event of high load changes in the primary network. A short circuit in the supply lines through the following fuse blowing causes a short and high current load.

## SYS POWER SUPPLY UM E

---

### Harmonics

Suppressing high-frequently reverse currents is explained in the EN 61000-3-2 standard. This standard is valid since January 1st, 2001, and is based on the predecessor standard EN 60555-2. EN 61000-3-2 is part of the basic EMC standard EN 61000-6-3 (noise emission) (see also section 3.18, "Harmonics").

This standard contains limit values for harmonic currents, which are determined with reference to the input network current. It is valid for all electrical devices that are intended for use on the public low-voltage network. The standard is only valid for 75 W to 1000 W devices used within the European Union.

With regard to noise emission, primary-switched mode QUINT POWER, MINI POWER and STEP POWER devices may be used in domestic applications as well as in industrial applications. Concerning noise emission this means that the limit values for harmonic currents must not be exceeded. A decisive factor for noise immunity is that interferences of any kind do not affect the function of a power supply unit.

### 3.12 Pollution Degree

Depending on their load and use, power supply units are exposed to certain environmental influences such as dust, humidity and aggressive substances. The resistance of an electrotechnical component to these influences is described by the pollution degree. The pollution degree is divided into classes from 1 through 4. For industrial use, power supply units with class 2 have proved to be effective. Non-conducting pollution may occur with class 2 devices. In the event of condensation, this pollution may temporarily become conductive.

Fields of application for class 2 devices are, for example, the domestic, sales and office areas, precision engineering workshops etc.

If class 2 power supply units are to be used in applications in which a higher degree of pollution must be expected, the power supply units are installed in a distribution cabinet with an appropriate degree of protection (see section 2.1, "Mechanical Structure").

### 3.13 Short-Term Mains Buffering

In many applications the power supply unit must also buffer the DC voltage during short-term interruptions of the supplying AC voltage.

For primary-switched mode power supply units this can be achieved with a minimum effort by buffering the 600 V DC voltage in the intermediate circuit using capacitors.

The aim should be mains buffering of at least 20 ms in order to be able to buffer the voltage dip of a complete line supply cycle.

For three-phase power supply units the mains buffering time is reduced in the event of a phase failure because the capacitors in the intermediate circuit have not been completely charged.

#### Emergency stop



To implement emergency stop circuits in conjunction with energy-storing power supply units, please refer to section 3.16, "Installation and Connection".

All QUINT POWER, MINI POWER and STEP POWER power supply units from Phoenix Contact are able to buffer the output voltage for more than 20 ms in the event of a power failure.

### 3.14 Starting Behavior of the Power Supply Unit

#### Active inrush current limiting instead of NTC

Particular attention should be paid to the starting behavior of the power supply units in warm operating state. The cost-effective circuit version protects the power supply unit inputs from high input currents by means of an ohmic resistor and an NTC thermistor connected in series. The disadvantages of these circuits for powerful devices are that electrical power is always converted to heat loss across the ohmic resistor, and that the NTC has a very low resistance when switching warm devices on again. With powerful devices ( $P > 250 \text{ W}$ ), low-resistance inputs allow inrush currents, which may become so high that the primary fuses blow unintentionally.

When using active current limiting the power supply unit input is also protected against high inrush currents by means of an ohmic resistor. However, this resistor is bypassed in normal operating mode, i.e., there are no losses. When using active inrush current limiting, starting up warm devices is no problem.

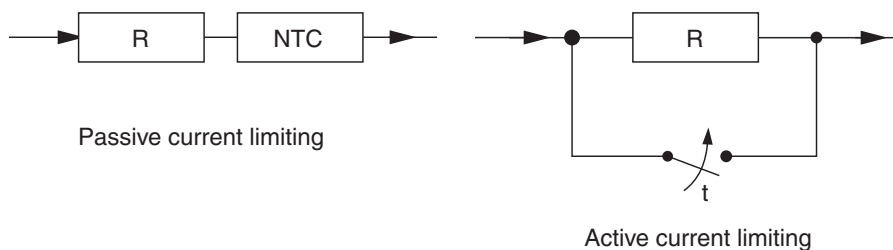

5598D028

Figure 3-25 Current limiting



All QUINT POWER power supply units from Phoenix Contact are provided with active inrush current limiting.

This ensures safe starting up of warm devices and provides high efficiency.

Due to their low output power, MINI POWER and STEP POWER are provided with passive inrush current limiting.

### 3.15 Output Characteristic Curves of Power Supply Units

A sound circuit concept is often revealed when it is first started. The output characteristic curve used is typical of the power supply unit behavior. The characteristic curve specifies the history of the output voltage as a function of the output current. It must be noted that capacitive loads (e.g., DC/DC converter or PTC thermistor) consume a much higher current during start up than during nominal operation.

Capacitive loads represent an overload or a short circuit for the power supply unit for a short time. It is therefore of great importance to the design of an operational system that the power supply unit does not interpret this transient overload or short circuit as an error and does not shut down. It greatly depends on the output characteristic curve to determine which loads can be safely started with which power supply unit.

For this reason, the different characteristic curves are explained in more detail in the following.

- When using the fold-back characteristic, power supply units switch off shortly in the event of a short circuit or an overload and restart the load after a short time.
- Power supply units with U/I characteristic continue to provide the complete output current while reducing the output voltage.
- Power supply units with U/I characteristic and power boost have the advantages of a U/I characteristic combined with an additional power reserve. The power reserve ensures a constant output voltage even in the event of an overload.

### 3.15.1 Fold-Back Characteristic

Power supply units with fold-back characteristic are electronically protected against overload and short circuit. The maximum output current is typically 1.1 times the nominal current. In the event of an overload the working point passes along the curve shown in Figure 3-26. Depending on the controller temperature and in the event of a short circuit the device output is switched off to be protected against high currents.

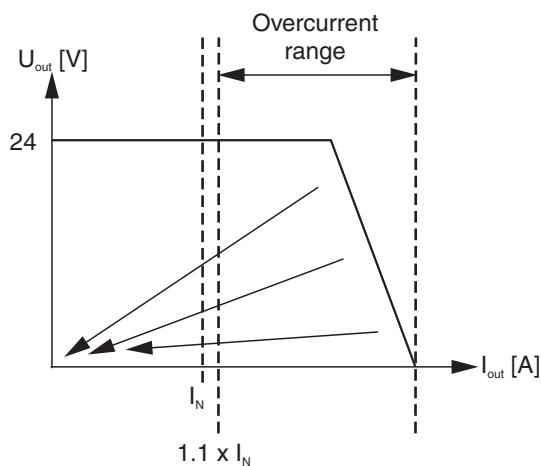

5598D017

Figure 3-26 Fold-back characteristic

After approximately one second the device tries again to start the connected load. This procedure is repeated until the overload or short circuit has been removed.

The power supply unit will not start the load in the event of an overload, which is caused by the high inrush current during starting up when using heavier loads. If these devices switch off too quickly in the event of a short circuit, secondary fuses will not blow. The faulty current path cannot be isolated from the remaining system parts. This results in a failure of the entire system.

### 3.15.2 U/I Characteristic

Power supply units with U/I characteristic are electronically protected against overload and short circuit. For a 24 V DC voltage, the maximum output current is typically 1.1 times the nominal current. In the event of an overload or a short circuit the output current of 1.1 times  $I_N$  is still available while the output voltage is reduced.

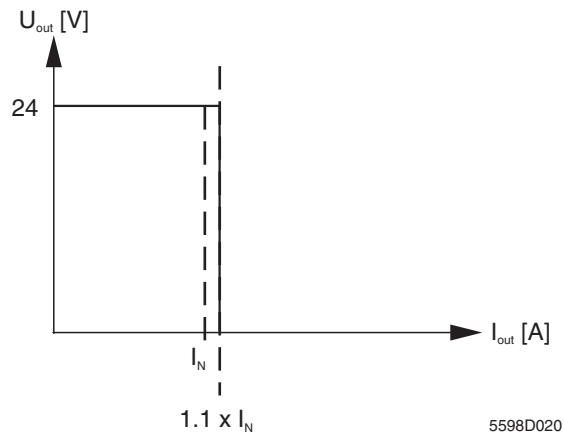

Figure 3-27 U/I characteristic

There are two significant advantages of using devices with U/I characteristic compared to using devices with fold-back characteristic:

- Capacitive loads of any size and loads with DC/DC converter can be started.
- When dividing the output into individual, selectively fused current paths reliable fuse blowing is ensured thanks to the continuous current (see also section 3.7, "Selective Protection by Means of Fusing in the Secondary Circuit").

This makes power supply units with this characteristic more suitable for use in the industrial area.

### 3.15.3 U/I Characteristic With Power Boost

Power supply units with U/I characteristic and power boost are electronically protected against overload and short circuit. At nominal voltage the maximum output current of these devices is up to two times the nominal current, depending on the type and ambient temperature.

Overloading individual power supply units is thus permitted up to 100%. In the event of heavier loads the working point uses the U/I curve shown in Figure 3-28. In the event of a short circuit the output current of up to two times the nominal current is still available while the output voltage is reduced.

The power reserve ensures that highly capacitive loads and loads with DC/DC converters in the input circuit are supplied at any time without problems.

In the event of a load short circuit, the high short circuit current ensures reliable fuse blowing in the secondary circuit in order to keep the selectivity.

These properties make power supply units with U/I characteristic and power boost optimally suitable for use in universal industrial applications.

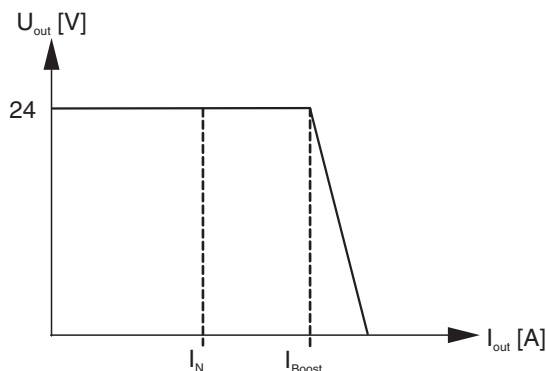

5598D307

Figure 3-28 U/I characteristic with power boost



QUINT POWER, MINI POWER and STEP POWER power supply units from Phoenix Contact operate according to the U/I characteristic and are provided with the power boost power reserve.

### 3.16 Installation and Connection

It is of decisive importance for quick and safe installation of industrial power supply units that the power supply unit can be mounted on DIN rails and is provided with a reliable connection method.



All Phoenix Contact power supply units can be mounted on DIN rails. This also applies to powerful devices with output currents of up to 40 A.

For quick device connection and visible isolation of the electrical connection, if required, all MINI POWER and QUINT POWER power supply units with an output current of up to 10 A are equipped with COMBICON connectors.

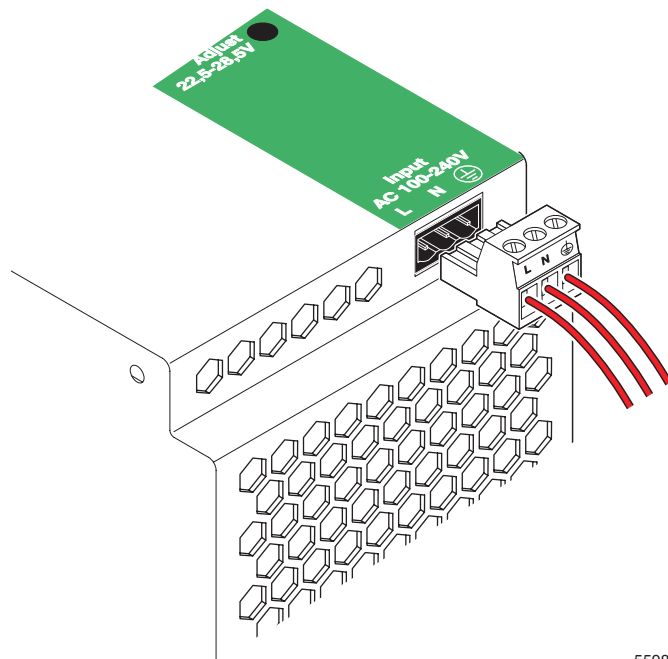

5598C404

Figure 3-29 Primary connection using COMBICON

## SYS POWER SUPPLY UM E

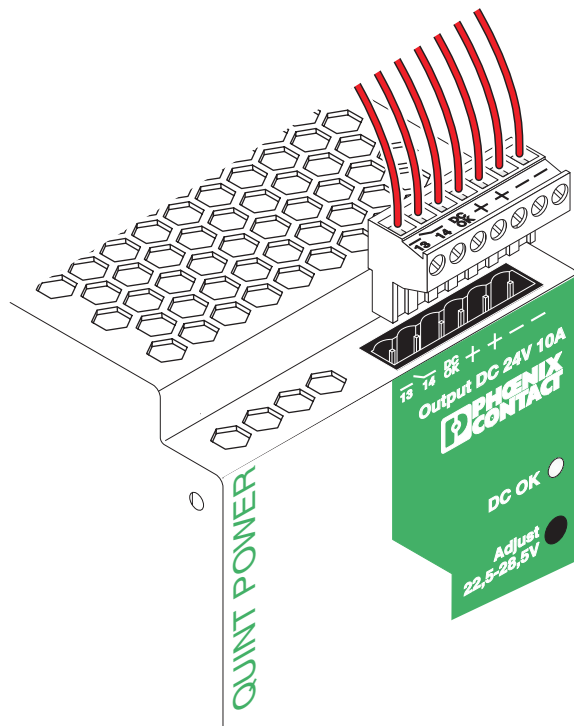

5598C402

Figure 3-30 Secondary connection using COMBICON

In these connector systems the supply lines are fastened to the connector using screws at initial installation. If required, the connector can be removed from the power supply unit without any tools. The connector must not be removed while power is connected. COMBICON connectors are being labeled by default.

It is therefore impossible to mix up the input and output connectors when using COMBICON devices. With MINI POWER, the COMBICON connector encoding prevents secondary connectors of power supply units with different output voltages from being mixed up.

QUINT POWER power supply units with output currents of 20 A and higher and STEP POWER power supply units are equipped with p.c.b. terminal blocks.

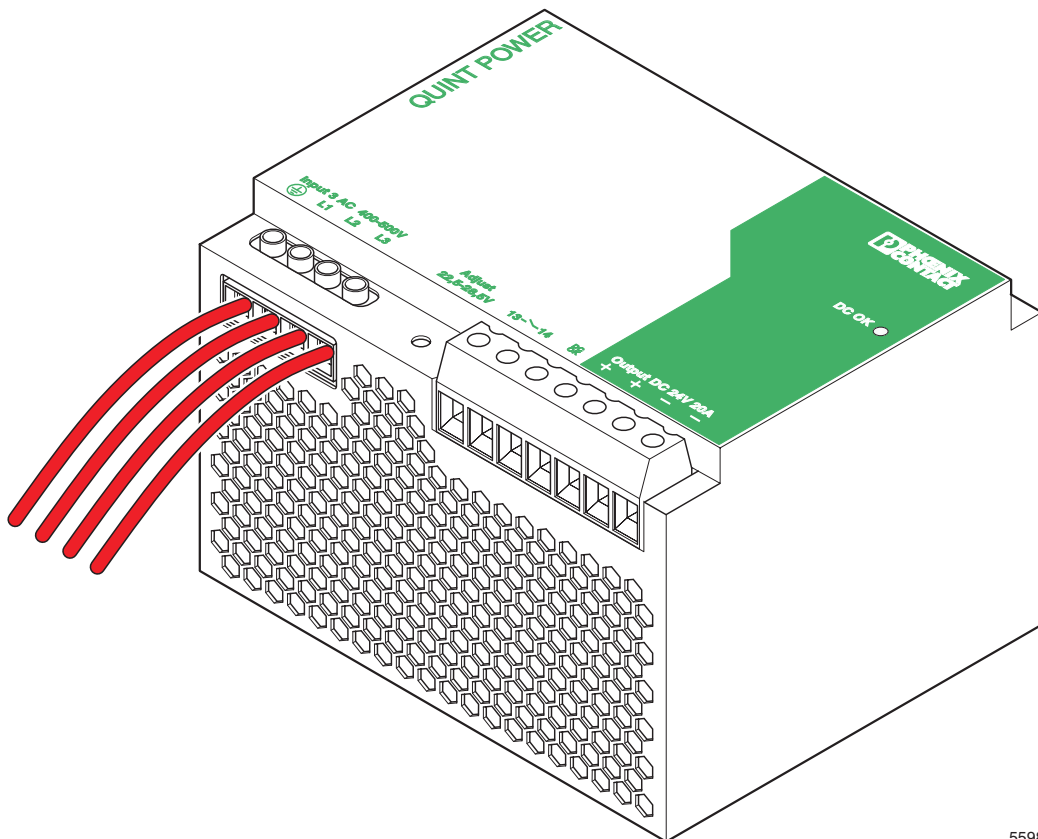

5598C401

Figure 3-31 Connection using p.c.b. terminal block

In order to handle high output currents safely and to enable the connection of cable cross sections of up to 10 mm<sup>2</sup> (8 AWG), p.c.b. terminal blocks are used for QUINT POWER with output currents of 20 A and higher.

To comply with the UL approval, use copper cables designed for operating temperatures of 75°C (167°F).

## SYS POWER SUPPLY UM E

### Installation turned by 90°

The DIN rail adapter, already mounted upon delivery, enables easy snapping on of the power supply unit onto the DIN rail. It is therefore ideal for the installation on NS 35 DIN rails.

QUINT POWER can be adapted to the geometric demands of the most different applications. By adjusting the universal DIN rail adapter, the devices may be installed if space requirements are either particularly narrow or flat (see Figure 3-32).

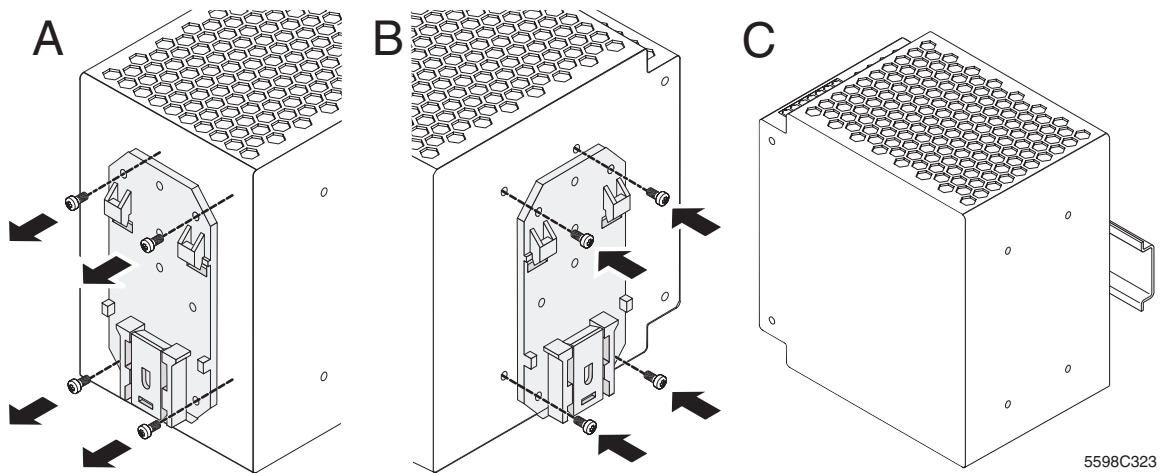

Figure 3-32 Installation turned by 90° (example: adjustment from narrow to flat)

## 3.17 Emergency Stop Circuit

In many applications with an integrated emergency stop circuit, switching off is carried out centrally in the AC circuit. When using power supply units with energy-storing intermediate circuits (this includes all primary-switched mode power supply units) it must be noted that there may be a DC current in the secondary circuit for a certain period of time when the primary circuit is switched off, e.g., in the event of an emergency stop. This effect has been deliberately implemented in the devices to buffer a possible power failure. To clearly isolate the loads connected to the primary-switched mode power supply units from the supply line, it is therefore recommended to use a relay circuit, which interrupts the secondary DC circuit.

### 3.18 Harmonics

Each power supply unit transforming an AC (line) voltage in a DC voltage in order to supply electrical loads generates unwanted harmonics. The functioning mode of the power supply unit used has no influence on the generation of harmonics.

Harmonics, which are generated by rectifiers with downstream smoothing capacitors or primary-switched mode power supply units, will be fed back into the electrical supply network if no appropriate limiting measures are taken. This affects sensitive electronic loads. Harmonics cause the power consumption of the loads to increase. Cable cross sections would unnecessarily need to be designed larger.

Harmonics are caused by a pulse-shaped current, which is generated by the current consumption of rectifiers with a downstream capacitance or primary-switched mode power supply units.

A simple rectifier with diode D1 and capacitance C1 is shown in Figure 3-33. The time history of voltage and current is shown in Figure 3-34. The  $U_{in}$  AC voltage is rectified by diode D1 and smoothed by capacitance C1. The pulse-shaped current  $I_{in}$  is generated when capacitance C1 is recharged with a positive half wave of the input voltage  $U_{in}$ . The capacitance is always recharged when the supply voltage  $U_{in}$  is higher than the voltage  $U_c$  across capacitance C1.

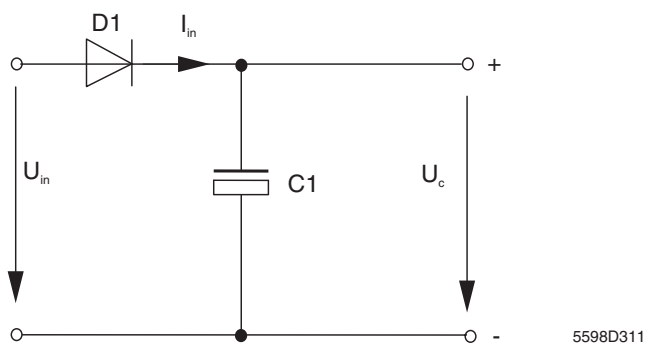

Figure 3-33 Rectifier with diode and capacitance

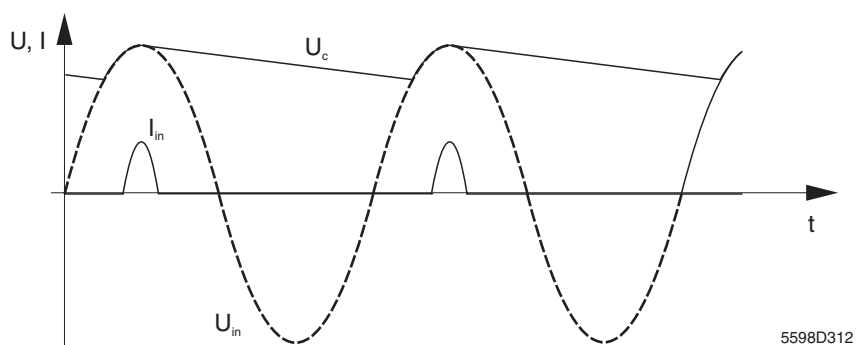

Figure 3-34 Time history of voltage and current

## SYS POWER SUPPLY UM E

---

All periodic functions can be evolved into a Fourier series, i.e., they can be divided into sinusoidal portions. The pulse-shaped current  $i_{in}$  can therefore be considered as a superimposition of a sinusoidal current with the network frequency as the basic frequency and several sinusoidal currents with integer multiples of this basic frequency. These currents are called harmonics (harmonic currents).

### Reactive power

The sum of all harmonic currents represents a reactive power. In addition to the real power  $P$  the reactive power  $Q$  must be provided from the supply network and paid by the system operator.

The relationship between consumed power (apparent power  $S$ ), actually provided power (real power  $P$ ) and reactive power  $Q$  is:

$$S^2 = P^2 + Q^2 \quad [5]$$

### Apparent power

The apparent power  $S$  is the product of the effective current and voltage values. The unit of the apparent power  $S$  is VA (Volt-Ampere):

$$S = \hat{U} \cdot \hat{I} \quad [6]$$

$$[S] = \text{VA}$$

### Power factor

The power factor  $\lambda$  indicates the ratio between the real power  $P$  and the apparent power  $S$ :

$$\lambda = \frac{P}{S} \quad [7]$$

According to formula [5] the power factor  $\lambda$  is reduced with increasing reactive power  $Q$  via the apparent power  $S$ .

Basically, there are two different types of reactive power: displacement power and distortion power. A distinction is made because both reactive powers are generated in different ways.

**Displacement power**

The reactive power that is occurring most often in the field of electrical power engineering is called displacement power. It is generated in AC circuits with linear capacitive and inductive loads.

With ohmic loads the current consumption is in phase with the sinusoidal voltage. In the load, the consumed apparent power  $S$  is completely converted to real power  $P$ . Reactive power  $Q$  is not generated and the value of the power factor  $\lambda$  is 1.

With capacitive or inductive loads, the current consumption also has a sinusoidal shape but is not in phase with the voltage (see Figure 3-35). In this example, the current lags behind the voltage. In general, the voltage lags behind the current when using capacitive loads and vice versa when using inductive loads.

The time shift between current and voltage is called phase displacement. The size of this displacement is measured by means of the phase displacement angle  $\varphi$ .

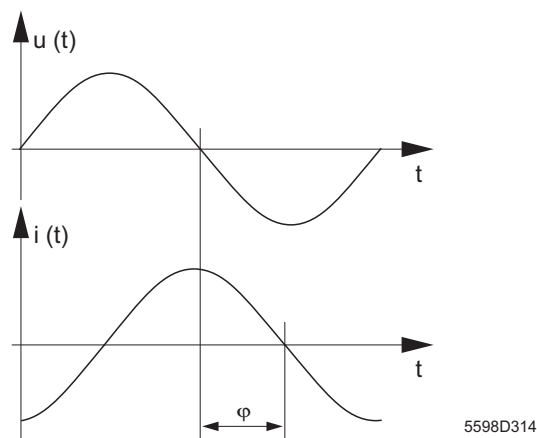

Figure 3-35 Phase displacement  $\varphi$

The real power  $P$  actually transformed in the load in the event of a phase displacement  $\varphi$  between current and voltage is the product of the effective values of current, voltage and cosine of the displacement angle  $\varphi$ . The unit of the real power  $P$  is W (Watt):

$$P = \hat{U} \cdot \hat{I} \cdot \cos \varphi \quad [8]$$

$$[P] = W$$

Because of the phase displacement the consumed apparent power  $S$  is not completely converted to real power  $P$  in the load. As a result, reactive power  $Q$  is generated.

If the reactive power  $Q$  is only generated by the phase displacement the power factor  $\lambda$  corresponds to the cosine of the displacement angle  $\varphi$  (according to formulas [7] and [8]).

$$\lambda = \frac{P}{S} = \frac{\hat{U} \cdot \hat{I} \cdot \cos \varphi}{\hat{U} \cdot \hat{I}} = \cos \varphi$$

Therefore, the terms power factor and  $\cos \varphi$  are often used as synonyms.

## SYS POWER SUPPLY UM E

---

### Distortion power

Non-linear loads, e.g., rectifiers with smoothing capacitors or primary-switched mode power supply units, often do not have a sinusoidal-shaped current consumption. Reactive power  $Q$  is generated, with these loads, due to a distorted current consumption and harmonic currents. This reactive power is called distortion power.

For calculating the apparent power  $S$  for non-linear loads, the sum of all harmonic currents is being considered.

$$S = \hat{U} \cdot \sum_n \hat{I}_n \quad [9]$$

$n$  = number of harmonics

The power factor  $\lambda$  is calculated according to the above formula:

$$\lambda = \frac{P}{S} \quad [7]$$

For non-linear loads the power factor  $\lambda$  does therefore not correspond to  $\cos \varphi$ . Phase displacement and  $\cos \varphi$  cannot be specified because there is no sinusoidal current consumption. For primary-switched mode power supply units the terms power factor and  $\cos \varphi$  must **not** be used as synonyms.

### EN 61000-3-2

The European Standard EN 61000-3-2 for the limitation of harmonics is valid since January 1st, 2001. This standard is valid for loads connected to the public network with a real power consumption of between 75 W and 1000 W. Loads with lower real power consumption or loads, which are supplied using a medium voltage transformer, must not comply with these standardized limit values. EN 61000-3-2 is valid for the European market. There are attempts to introduce similar standards to the US market.

Feedback of harmonics into the supply network may technically be prevented by means of two methods: PFC or harmonic filters. Both methods will be explained in the following.

### 3.18.1 Harmonic Filter (Inductance)

Harmonic filters prevent harmonics from feeding back into the electrical supply network. Using inductance  $L_1$  in the primary circuit of the power supply unit the harmonic content is filtered. Figure 3-37 shows a simple rectifier with inductance  $L_1$  as an example. Because of using a filter this limiting method is often called passive limitation of harmonics.

Figure 3-36 shows the pulse-shaped current curve of a power supply unit with and without harmonic inductance. The inductance causes the narrow and high-energy current pulse to be attenuated and enlarged in time. This reduces the amount of harmonics. The shorter and higher a current pulse the more harmonics are generated.

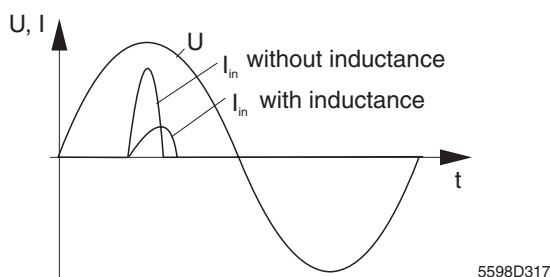

Figure 3-36 Harmonic filter

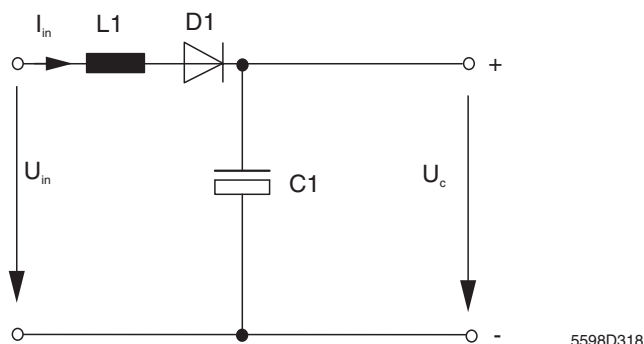

Figure 3-37 Simple rectifier with inductance

### 3.18.2 PFC

Ideally, the generation of harmonics is already avoided when using primary-switched mode power supply units. With a sinusoidal current consumption the power supply unit responds like a linear load. Harmonics and distortion power are not generated. The power factor increases with reduced reactive power. Ideally, the apparent power is completely converted to real power. In this case, the power factor is exactly one.

In order to draw sinusoidal-shaped current from the supply network an additional and complicated circuit is required. This complicated circuit is correctly known as PFC (Power Factor Correction). PFC is often called active limitation of harmonics.

A PFC circuit usually exists in a step-up transformer. Figure 3-38 shows the simplified structure of a PFC circuit with a downstream flyback converter. The step-up transformer is also a power supply unit. It basically consists of the coil L1, the diode D2 and the power switch S1.

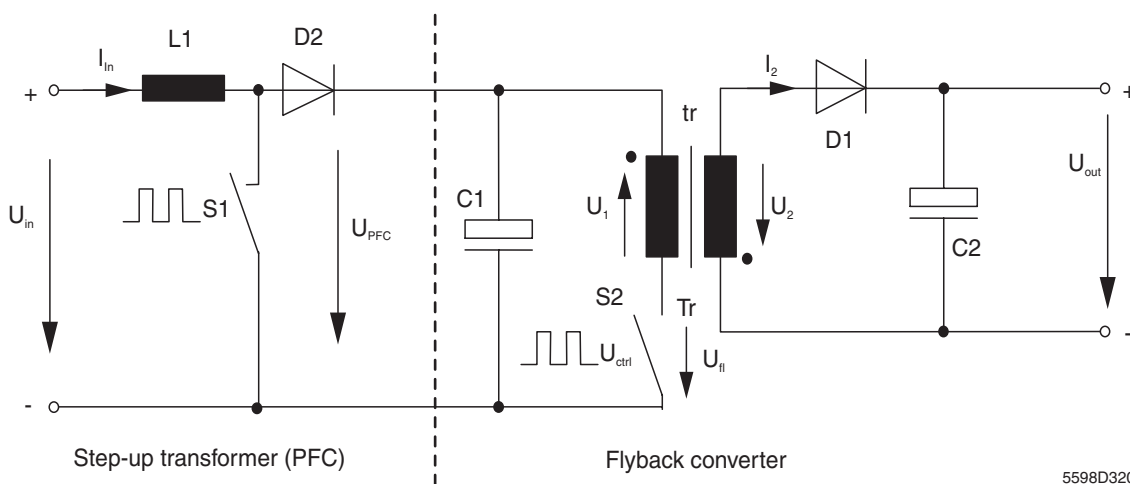
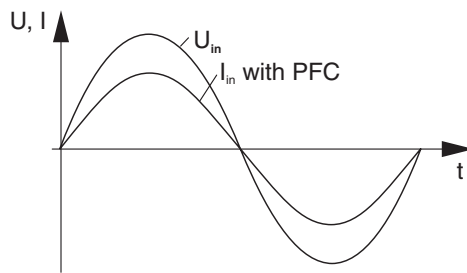

Figure 3-38 PFC with downstream flyback converter

Power switch S1 is controlled by controlling the step-up transformer. The closed-loop control circuit controls the input current  $I_{in}$ . The sinusoidal voltage  $U_{in}$  serves as the setpoint definition. This makes the current consumption  $I_{in}$  follow the sinusoidal voltage, as shown in Figure 3-38.

At the output the step-up transformer generates the constant voltage  $U_{pfc}$ , which is independent from the line frequency. This voltage is always higher than the maximum supply voltage of  $U_{in}$ . Capacitor C1 is therefore permanently being charged and thus buffers the pulse-shaped current consumption of the flyback converter.



5598D319

Figure 3-39 Limitation of harmonics by means of PFC



All QUINT POWER, MINI POWER and STEP POWER power supply units from Phoenix Contact are below the limit values for harmonics and comply with EN 61000-3-2.

### 3.19 Approvals

Each device must comply with the safety directives of the country in which the device is intended to be used. For power supply units this, for example, applies to the device safety, which is defined by EN 60950 in Europe, by UL 60950 in the USA and by CSA-C22.2 in Canada.

For industrial applications, compliance with EN 50178 is often required in Europe and with UL 508 in the USA.

With the CE certification the manufacturer guarantees that the device is being developed, produced and sold according to the applicable directives of the European Union. Particularly for power supply units compliance with the low voltage directive and the EMC directive is required.

Further approvals not being required by law underline additional safety: In Germany, the approval "Geprüfte Sicherheit (GS)" (approved safety) provides an additional safety certification for devices. The approval "Germanischer Lloyd (GL)" (German Lloyd) certifies maximum reliability under extreme climatic conditions and maximum vibration resistance in continuous operation.

The following table lists the major approvals:

Table 3-13 Approvals

Standard	Meaning
EN 60950	Electrical safety for information technology equipment
UL 60950	US version of EN 60950
EN 50178	Electronic equipment for use in power installations
UL 508	US safety standard for industrial control systems, similar to EN 50178
EN 61000-3-2	Limits for harmonic currents in the public network
EN 60204	Electrical equipment of machines
EN 61558-2-17	Safety transformers for power supply units
EN 61000-6-3/ EN 50082	Basic standard on electromagnetic compatibility (EMC)
GS	Geprüfte Sicherheit (approved safety) (see below)
CE	EU declaration of conformance
GL	Germanischer Lloyd (German Lloyd) (see below)
CB Scheme	Basic safety certification (see below)

**Geprüfte Sicherheit (GS) (Approved Safety)**

"GS" stands for "Geprüfte Sicherheit" (approved safety). It is a European certification for devices according to the German Equipment Safety Law "GS". It is provided for products, which are included in the application area of the equipment safety law. This application area includes power supply units because the minimum distance, for example, between line voltage and output voltage is important for safety-related considerations.

The "Geprüfte Sicherheit" (approved safety) mark is issued by an approved body (e.g., TÜV = Technischer Überwachungsverein [technical supervision body]) when carrying out a type approval test. For testing the safety features of the power supply units, the insurance conditions against occupational accidents (German: Berufsgenossenschaft) are applied. These conditions are much more difficult to fulfill than the demands of the European Machinery Directive (CE mark).

**Germanischer Lloyd (GL) (German Lloyd)**

The German Lloyd approval is a type approval test required in naval and offshore engineering. Power supply units with this approval fulfill maximum demands with regard to the climatic and mechanical environment.

**CB Scheme**

CB Scheme is operated by numerous international safety-related committees of different countries and testing organizations. CB Scheme developed a system for approvals dealing with the safety of electrical and electronic products. A power supply unit tested according to CB Scheme safety directives can obtain national certification in all other member countries of the CB Scheme.

**SYS POWER SUPPLY UM E**

---

## 4 Selecting a Power Supply Unit

Selecting a power supply unit for a specific application is the subject of this section. The power supply unit is selected successively on the basis of the following two lists of questions: "mechanical structure" and "electrical structure". All terms used are explained in section 2, "Basics".

The following must be considered for devices, which are mainly used in the control cabinet for industrial applications:

### **What kind of shock protection is required?**

Protection against finger contact of dangerous parts is ensured as from IP20 class of protection.

### **What kind of water protection is required?**

As from IP23, devices are protected against spraying water. For higher demands, installation in a control cabinet with appropriate class of protection is necessary.

Phoenix Contact recommends IP20 class of protection for devices installed in a control cabinet.

### **What kind of shock/vibration resistance is required?**

The vibration resistance for industrial applications should be 2.3g (g = gravitational acceleration).

Shock resistance of 30g ensures safety transportation of preassembled control cabinets.

### **Which device is required for which supply voltage?**

Thanks to the wide-range input the power supply unit can be used all over the world. This simplifies the choice of a suitable device. At the same time logistics is reduced because only one device type is required for one performance class.

### **What installation options are required?**

For devices installed in a control cabinet mounting on NS 35 DIN rails according to EN 50022 has proved to be most suitable. A universal mounting rail adapter ensures easy mounting on and removal from the DIN rail.

With QUINT POWER devices the mounting rail adapter can be replaced by a special S7 adapter to enable mounting on different mounting rail systems (e.g., S7-300 rail).

## SYS POWER SUPPLY UM E

---

Table 4-1 Device comparison

	Unregulated, Filtered	Linearly Regulated	Primary-Switched Mode
<b>Weights for the same performance range (standardized)</b>	5	7	1
<b>Volume for the same performance range (standardized)</b>	2.1	2.2	1
<b>Efficiency</b>	80%, approx.	40% to 60%, approx.	> 90%
<b>Power dissipation at <math>P_{out} = 1000\text{ W}</math></b>	200 W, approx.	600 W, approx.	< 75 W
<b>Input range</b>	$-10\% < U_n < +6\%$	$-10\% < U_n < +6\%$	$-20\% < U_n < +15\%$ , approx.
<b>Output voltage</b>	Depending on input voltage and load	Precisely adjusted	Precisely adjusted; adjustable versions available 22.5 V DC to 28.5 V DC
<b>Residual ripple</b>	2000 mV <sub>pp</sub> , approx.	50 mV <sub>pp</sub> , approx.	< 100 mV <sub>pp</sub>
<b>Short-circuit current</b>	10 x I <sub>N</sub> , approx.	2 to 3 x I <sub>N</sub> , approx.	1.1 to 1.5 x I <sub>N</sub> , approx. (U/I characteristic, no switch off)
<b>Field of application</b>	Electromechanical engineering	Highly sensitive analog technology	Universally applicable

## 4.1 Supplying Electromechanical Components

Phoenix Contact generally recommends using enclosed devices for industrial applications because they ensure particularly high protection of persons and systems.

A regulated output voltage is not generally required for supplying electromechanical components such as valves, relays or electromagnetic switches.

It is therefore sufficient to use an unregulated power supply unit for this.

If, additionally, reduced space requirement and high efficiency are demanded, Phoenix Contact recommends using primary-switched mode power supply units.

## 4.2 Supplying Electronic Modules and Systems

Open frame devices are often used for supplying devices inside an existing housing. 19" slide-in modules are most common for this.

For safety reasons the use of enclosed devices is recommended in control cabinets.

The use of regulated power supply units providing a stable 24 V DC output voltage independent of input voltage fluctuations and the connected load has proved to be effective for supplying electronic modules and systems.

In recent years, the technical development of electronic components has led to primary-switched mode devices being used more and more instead of linearly regulated devices. The major reasons for using primary-switched mode devices are high efficiency and the associated low heat dissipation, low weight and compact design.

Phoenix Contact recommends primary-switched mode devices for universal use.



Phoenix Contact offers regulated, primary-switched mode power supply units with output currents of 1 a to 40 A covering the complete voltage range of 5, 10, 12, 15, 24 and 48 V DC (QUINT POWER, MINI POWER and STEP POWER devices).

For supplying highly sensitive analog technology, linearly regulated devices still maintain their position. Compared to earlier primary-switched mode controllers, linearly regulated power supply units generate a smoother output voltage, which is almost free from residual ripple and switching peaks.

### 4.3 Using Power Supply Units on Strongly Fluctuating Networks

Strongly fluctuating input networks are on the one hand present in countries which do not have a stable interconnected network, and on the other hand when starting and braking large electric motors.

In these cases, it is unsuitable to use unregulated devices because the input voltage fluctuations are directly transferred to the output voltage. Phoenix Contact recommends using primary-switched mode power supply units for unstable networks. These devices provide a fixed output voltage even in the event of a strongly fluctuating input voltage.

### 4.4 Installation in Distributed Control Cabinets

In the field of automation technology, a growing trend away from central control cabinets and towards distributed control cabinets can be observed. Power supply units for use in distributed control cabinets must above all meet two important requirements: flat design and very high efficiency to keep the power dissipation to a minimum.



The primary-switched mode QUINT POWER, MINI POWER, and STEP POWER power supply units from Phoenix Contact meet both requirements (flat design and high efficiencies of approx. 90%).

## 4.5 Applications in Building Services Automation/ Facility Management

Electrical power is mainly supplied to buildings via the public low-voltage network. Compliance with EN 55022, Class B, is essential for equipment in the commercial, business and domestic sector. In addition, all power supply units connected to the public network must comply with the European standard EN 61000-3-2 on limitation of harmonic currents.

EN 61000-3-2 is valid since January 1st, 2001. All power supply units above 75 W connected to the public supply network must comply with this standard. Irrespective of compliance with the standard, it is useful from an electrical point of view to equip power supply units with a filter for suppressing network harmonics, in order to avoid undesirable interference with other electronic components.



All QUINT POWER, MINI POWER and STEP POWER power supply units from Phoenix Contact comply with both standards.

Power supply units with a flat design are suitable for installation in junction and sub-distribution boxes as well as in operating panels. STEP POWER power supply units have a flat double-step housing with standardized dimensions.

## 4.6 Outlook

In the field of electrical engineering the level of innovation - i.e., continual innovation - increases at an enormous rate. To the same extent the life cycle of the products becomes shorter.

The technical development of electrotechnical systems and components follows two directions:

- Expensive mechanical and electromechanical components are more and more being replaced by electronic solutions.
- Centrally structured electrical installations and systems are continuously being supplemented or even replaced by distributed electronics.

Power supply units are taking on the central task of supplying electrical modules and systems with the established 24 V control voltage. The use of regulated power supply units is recommended for electronic components.

In the past, the devices were large and heavy. Together with their high heat loss this contributed to the undesirable control cabinet heating.

The trend towards distributed electronics provide a new role for power supply units. Today, the reliability of power supply units is not only responsible for the availability of individual components but also for safe and reliable operation of complex systems. Thanks to developments in the field of power electronics it is possible to introduce primary-switched mode devices, which have four important advantages over conventional linearly regulated power supply units:

- Weight reduced by a factor of 3 to 5
- Increased efficiency from approx. 50% to 90%, and consequently
- Heat loss reduced by a factor of 5
- Volume reduced by a factor of 1.5

The future definitely lies with regulated primary-switched mode power supply units.



Phoenix Contact has recognized this development at an early stage, and now offers the complete performance range from 15 W to 960 W in a uniform design with its QUINT POWER, MINI POWER, and STEP POWER primary-switched mode controllers.

## 5 Product Overview



For ordering data on the Phoenix Contact power supply units, please refer to the Phoenix Contact INTERFACE catalog and to the internet at [www.interface.phoenixcontact.com](http://www.interface.phoenixcontact.com).

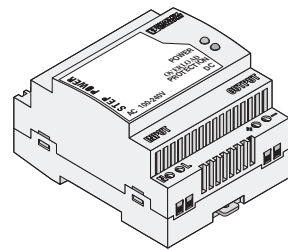
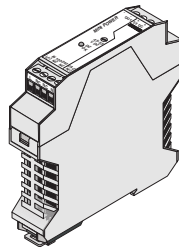
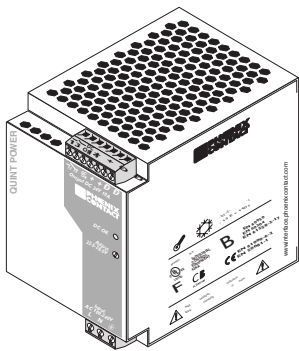

5598C420

Figure 5-1 QUINT POWER, MINI POWER, and STEP POWER

**SYS POWER SUPPLY UM E**

---

# A Appendices

## A 1 List of Figures

### Section 2

Figure 2-1:	Open frame device .....	2-2
Figure 2-2:	Enclosed device (example: QUINT POWER 20A/3-phase) .....	2-3
Figure 2-3:	Assignment of technical data .....	2-4
Figure 2-4:	Without secondary grounding .....	2-7
Figure 2-5:	With secondary grounding .....	2-8
Figure 2-6:	Secondary protection .....	2-9
Figure 2-7:	Circuit diagram for unregulated devices .....	2-10
Figure 2-8:	Circuit diagram for linearly regulated devices .....	2-11
Figure 2-9:	Circuit diagram for primary switched-mode devices .....	2-12
Figure 2-10:	Pulse duty factor diagram .....	2-13
Figure 2-11:	Converter types .....	2-14
Figure 2-12:	Flyback converter with switch S1 closed .....	2-16
Figure 2-13:	Flyback converter with switch S1 opened .....	2-16
Figure 2-14:	Characteristic curves of voltage and current for flyback converters .....	2-17
Figure 2-15:	Flyback converter with two transistors .....	2-18
Figure 2-16:	Forward converter with power switch S1 closed .....	2-20
Figure 2-17:	Forward converter with power switch S1 opened .....	2-20
Figure 2-18:	Characteristic curves of current and voltage for forward converters .....	2-22
Figure 2-19:	Half-bridge push-pull converter .....	2-23

### Section 3

Figure 3-1:	Voltage balancing (1st step) .....	3-1
Figure 3-2:	Voltage balancing (2nd step) .....	3-2
Figure 3-3:	Example with additional load .....	3-3
Figure 3-4:	Example with 25 A load .....	3-4
Figure 3-5:	<b>Correct</b> parallel connection in the secondary circuit .....	3-5
Figure 3-6:	<b>Incorrect</b> parallel connection in the secondary circuit .....	3-6
Figure 3-7:	One-phase redundancy operation .....	3-8
Figure 3-8:	Three-phase redundancy operation .....	3-9

**SYS POWER SUPPLY UM E**

Figure 3-9:	Series connection .....	3-11
Figure 3-10:	Output voltage OK .....	3-13
Figure 3-11:	Output voltage not OK .....	3-14
Figure 3-12:	DC OK switching output .....	3-15
Figure 3-13:	Electrically isolated contact .....	3-15
Figure 3-14:	Early error detection with power boost and DC OK .....	3-16
Figure 3-15:	Monitoring multiple power supply units using only one signal .....	3-17
Figure 3-16:	Cable length .....	3-20
Figure 3-17:	Connection of a one-phase power supply unit .....	3-24
Figure 3-18:	Connection of a three-phase power supply unit .....	3-25
Figure 3-19:	US network configurations (one-phase) .....	3-26
Figure 3-20:	US network configurations (three-phase) .....	3-27
Figure 3-21:	Selective protection .....	3-28
Figure 3-22:	Cable length .....	3-32
Figure 3-23:	Voltage across the load .....	3-33
Figure 3-24:	TN-S network .....	3-34
Figure 3-25:	Current limiting .....	3-38
Figure 3-26:	Fold-back characteristic .....	3-40
Figure 3-27:	U/I characteristic .....	3-41
Figure 3-28:	U/I characteristic with power boost .....	3-42
Figure 3-29:	Primary connection using COMBICON .....	3-43
Figure 3-30:	Secondary connection using COMBICON .....	3-44
Figure 3-31:	Connection using p.c.b. terminal block .....	3-45
Figure 3-32:	Installation turned by 90° (example: adjustment from narrow to flat) .....	3-46
Figure 3-33:	Rectifier with diode and capacitance .....	3-47
Figure 3-34:	Time history of voltage and current .....	3-47
Figure 3-35:	Phase displacement $\varphi$ .....	3-49
Figure 3-36:	Harmonic filter .....	3-51
Figure 3-37:	Simple rectifier with inductance .....	3-51
Figure 3-38:	PFC with downstream flyback converter .....	3-52
Figure 3-39:	Limitation of harmonics by means of PFC .....	3-53

**Section 5**

Figure 5-1:	QUINT POWER, MINI POWER, and STEP POWER .....	5-1
-------------	---	-----

## A 2 Explanation of Abbreviations

### General Abbreviations:

<b>CE</b>	<b>Communauté Européenne</b> (conformity mark)
<b>CSA</b>	<b>Canadian Standards Association</b>
<b>COMBICON</b>	<b>Combined Connection</b>
<b>DIN</b>	<b>Deutsche Industrie Norm</b> (German Standards Associations)
<b>ELV</b>	<b>Extra Low Voltage</b>
<b>EMV</b>	<b>ElectroMagnetic Compatibility</b>
<b>EN</b>	<b>European Standard</b>
<b>EVU</b>	<b>Elektrizitäts-Versorgungs-Unternehmen</b> (power supply company)
<b>GS</b>	<b>Geprüfte Sicherheit</b> (approved safety)
<b>IEC</b>	<b>International Electrotechnical Commission</b>
<b>ISO</b>	<b>International Organization for Standardization</b>
<b>LS switch</b>	<b>Leitungsschutzschalter</b> (circuit breaker)
<b>NTC</b>	<b>Negative Temperature Coefficient</b>
<b>PELV</b>	<b>Protective Extra Low Voltage</b>
<b>RC</b>	<b>Recognized Component</b>
<b>SELV</b>	<b>Safety Extra Low Voltage</b>
<b>UPS</b>	<b>Uninterruptible Power Supply</b>
<b>UL</b>	<b>Underwriters Laboratories</b>
<b>VDE</b>	<b>Verband Deutscher Elektrotechniker e.V.</b> (German Association of Electrical Engineers)

**SYS POWER SUPPLY UM E**

---

**Technical Abbreviations:**

<b>AC</b>	<b>A</b> lternating <b>C</b> urrent
<b>DC</b>	<b>D</b> irect <b>C</b> urrent
<b>f</b>	Frequency
<b>I</b>	Electrical current
<b>IP Code</b>	<b>I</b> nternational <b>P</b> rotection Code Two-digit number indicating the degree of protection. The first number indicates the shock protection in ascending order and the second number indicates the foreign body protection in ascending order.
<b>l</b>	Length
<b>LED</b>	<b>L</b> ight <b>E</b> mitting <b>D</b> iode
<b>L1, L2, L3</b>	External AC conductors
<b>N</b>	Neutral conductor
<b>N.N.</b>	<b>N</b> ormal <b>N</b> ull (above sea level)
<b>P</b>	Power
<b>PE</b>	<b>P</b> rotective <b>E</b> arth
<b>PFC</b>	<b>P</b> ower <b>F</b> actor <b>C</b> orrection
<b>U</b>	Electrical voltage

**Units**

<b>A</b>	Ampere (unit of the electrical current)
<b>Ah</b>	Ampere hours (unit of electricity)
<b>°C</b>	Degrees Celsius (unit of temperature)
<b>g</b>	Gravitational acceleration
<b>Hz</b>	Hertz (unit of frequency)
<b>m</b>	Meter (unit of length)
<b>ms</b>	Millisecond (1/1000 second)
<b>Ω</b>	Ohm (unit of electrical resistance)
<b>s</b>	Second (unit of time)
<b>V</b>	Volt (unit of electrical voltage)
<b>V<sub>pp</sub></b>	Volt peak-to-peak (peak voltage)

**SYS POWER SUPPLY UM E**

---

## A 3 Index

### A

Apparent power ..... 3-48  
Automation technology ..... 4-4

### B

Building services automation ..... 4-5

### C

Class of protection I ..... 2-5  
Class of protection II ..... 2-5  
COMBICON ..... 3-43  
Contactors ..... 2-10  
Control cabinet, distributed ..... 4-4  
Current path ..... 3-28

### D

Degree of protection ..... 2-1  
Device structure, mechanical ..... 2-1  
DIN VDE 0106 Part 1 ..... 2-5  
DIN VDE 0106 Part 101 ..... 2-6  
Displacement power ..... 3-48, 3-49  
Distortion power ..... 3-48, 3-50  
Domestic sector ..... 3-35

### E

Early error detection ..... 3-12, 3-16  
Electrical isolation ..... 2-5  
Electromagnetic switch ..... 2-10  
EMC standards ..... 3-35  
Emergency stop ..... 3-46  
EN 60529 ..... 2-1  
EN 61000-6-2 ..... 3-35  
EN 61000-6-3 ..... 3-35  
Enclosed devices ..... 2-3  
EU conformity ..... 3-35

### F

Facility management ..... 4-5  
Flyback converter ..... 2-15  
Fold-back characteristic ..... 3-40  
Foreign body protection ..... 2-1  
Function monitoring, preventive ..... 3-12

Fuse ..... 3-28  
Fuse, secondary-circuit ..... 3-30  
Fuses ..... 3-31

### G

Ground fault ..... 2-7, 2-8

### H

Harmonic filter ..... 3-51  
Harmonics ..... 3-47  
Housing ..... 2-1, 2-3

### I

IEC 60068-2-27 ..... 2-1  
IEC 60068-2-6 ..... 2-1  
Increasing power ..... 3-1, 3-3  
Industrial sector ..... 3-35  
Input variables ..... 2-4  
Inrush currents ..... 3-38  
Installation altitudes ..... 2-5  
IP (International Protection) code ..... 2-1

### L

Limitation of harmonics, active ..... 3-52  
Limitation of harmonics, passive ..... 3-51

### M

Mains buffering ..... 3-37

### N

Network configurations ..... 3-24  
Noise emission ..... 3-35  
NTC ..... 3-38

### O

Output variables ..... 2-4

### P

P.c.b terminal blocks ..... 3-45  
Parallel connection ..... 3-1  
PFC ..... 3-52  
Pollution degree ..... 3-36

**SYS POWER SUPPLY UM E**

---

Power boost.....	3-16, 3-39, 3-42
Power distribution .....	3-1
Power factor correction.....	3-52
Power reserve.....	3-39, 3-42
Primary switched-mode controller .....	2-12
Protective earth ground .....	2-5
Push-pull converter.....	2-14

**R**

Reactive power .....	3-48
Real power.....	3-48
Redundancy.....	3-1
Regulation types .....	2-10

**S**

Safe isolation .....	2-6
Safety extra low voltage.....	2-6
Selective protection .....	3-28
SELV.....	2-6
Shock.....	2-1
Shock protection .....	2-1
Short-circuit current .....	3-29
Single-ended converter.....	2-14
Starting behavior.....	3-38

**T**

Transport conditions .....	2-1
----------------------------	-----

**V**

Vibration.....	2-1
Voltage doubling .....	3-11

**W**

Water protection .....	2-1
Wide-range input .....	3-23



# SCATTERGOOD & JOHNSON LTD

ELECTRICAL ENGINEERING & FLUID CONTROL DISTRIBUTORS

Est.1899

At Scattergood & Johnson Ltd, we pride ourselves on being a technical distributor to specialist industries.

Working with a range of quality product suppliers across a number of specialist markets, we are not your average 'box shifter' - we are your technical and supply chain partner.

We fully support every product we sell - for free! Our internal team and external sales engineers can answer any product or application question, no matter the complexity.

Backing up this technical ability is a range of 50,000+ products available from stock for nationwide next day delivery (same day if required!), or you can collect what you need from any of our trade counters around the UK.

Select your specialist interest below to learn more about how we can help.

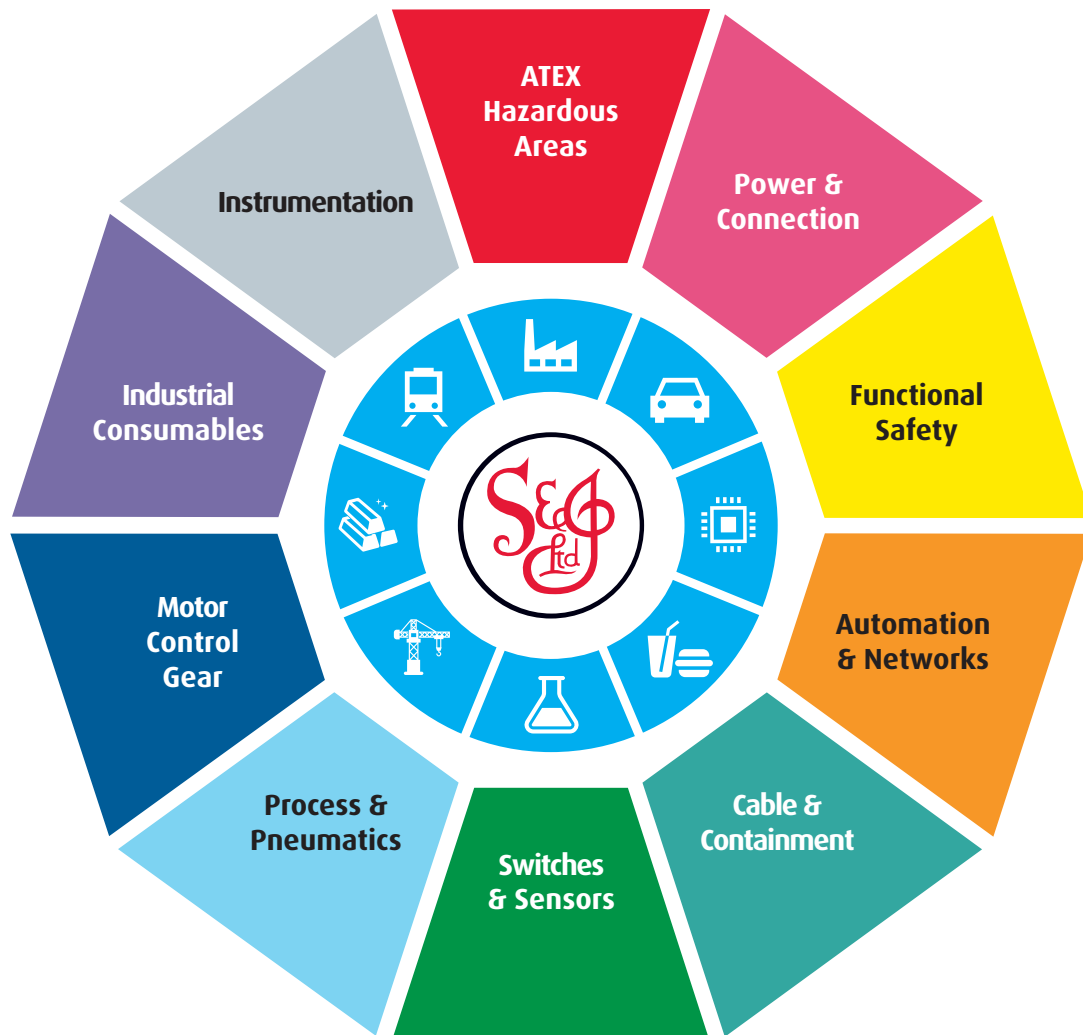

Online, In Branch and On the Road - Scattergood & Johnson Ltd, there when you need us.

# [www.scatts.co.uk](http://www.scatts.co.uk)