

TRIO-PS/1AC/48DC/ 5

**Primary switched power supply, 1-phase,
output current: 5 A**

INTERFACE

Data Sheet
103349_en_00

© PHOENIX CONTACT - 05/2008



1 Description

TRIO POWER is the DIN-rail-mountable power supply unit with basic functions. With an output voltage of 12 V DC, 24 V DC and 48 V DC and 1- and 3-phase versions with 60 W or 960 W, it is particularly suited for use in series production in mechanical engineering. The wide-range input and international certification package allows worldwide implementation.

The high MTBF of 500,000 h stands for high supply reliability. The devices can be connected in parallel to increase the capacity and redundancy.

The clear LED signaling and the device connection with double terminal block for plus and minus for fast potential distribution are further advantages of this device series. A third terminal block simplifies the grounding on the secondary side. All power supply units are idle proof and short circuit proof and provide a regulated and adjustable output voltage.

Features

- Reliable power supply unit even at high ambient temperatures
- No load and short circuiting resistance
- High dielectric strength
- Can be used worldwide in all industrial sectors due to a wide-range input and an international approval package



DANGER OF EXPLOSION!

Only remove equipment when it is disconnected and not in the potentially explosive area.



DANGER

Components with dangerously high voltage and high stored energy are located in the device!
Never carry out work on live parts!
Depending on the ambient temperature and the load, the housing can become very hot!



Make sure you always use the the latest documentation.
It can be downloaded at www.download.phoenixcontact.com.
A conversion table is available on the Internet at www.download.phoenixcontact.com/general/7000_en_00.pdf.

2 Table of contents

1	Description	1
2	Table of contents	2
3	Ordering data	3
4	Technical data	3
5	Structure	6
6	Block diagram	7
7	Safety notes	7
8	Installation	8
9	Installation position	8
10	Mounting on DIN rails	9
	Assembly	9
	Removing	9
11	Connection to various systems	9
12	Input	10
	Recommended backup fuse for mains protection	10
13	Output	11
	Protection of the secondary side	11
14	Signaling	11
15	Function	12
	Output characteristic curve	12
	Thermal behavior	12
	Parallel operation	12
	Redundant operation	13
	Increased performance	13

3 Ordering data

Description	Type	Order No.	Pcs. Pkt.
Primary switched power supply, 1-phase, output current: 5 A	TRIO-PS/1AC/48DC/ 5	2866491	1

4 Technical data

Input data	
Input nominal voltage range	100 V AC ... 240 V AC
AC input voltage range	85 V AC ... 264 V AC
AC frequency range	45 Hz ... 65 Hz
Current consumption	Approx. 2.5 A (120 V AC) Approx. 1.3 A (230 V AC)
Inrush current limitation	< 15 A
I^2t	< 0.7 A ² s
Power failure bypass	> 15 ms (120 V AC) > 16 ms (230 V AC)
Typical response time	< 1 s
Protective circuitry	Transient surge protection Varistor
Recommended backup fuse for mains protection	10 A (characteristic B) 16 A (characteristic B)
Discharge current to PE	< 3.5 mA
Output data	
Nominal output voltage	48 V DC \pm 1%
Setting range of the output voltage	30 V DC ... 56 V DC (> 48 V constant capacity)
Output current	5 A (-25°C ... 70°C)
Derating	Above +55°C: 2.5% per Kelvin
Current limitation	Approx 5.7 A (in the event of a short circuit)
Max. capacitive load	Unlimited
Control deviation	< 1 % (change in load, static 10% ... 90%) < 2 % (change in load, dynamic 10% ... 90%) < 0.1 % (change in input voltage \pm 10%)
Power loss nominal load max.	28 W
Maximum power dissipation idling	3.5 W
Efficiency	> 89 %
Ascent time	< 2 ms (U_{OUT} (10% ... 90%))
Residual ripple	< 50 mV _{PP}
Peak switching voltages	< 50 mV _{PP}
Connection in parallel	Yes, for redundancy and increased capacity
Connection in series	No
Surge protection against internal surge voltages	yes, limited to approx. 60 V DC
Resistance to reverse feed	60 V DC
Signal output DC OK active	
Status display	"DC OK" LED green / $U_{OUT} < 0.9 \times U_N$: LED flashing

General data

Insulation voltage input/output	4 kV AC (type test) 2 kV AC (routine test)
Insulation voltage input / PE	2 kV AC (type test) 2 kV AC (routine test)
Insulation voltage output / PE	500 V DC (type test)
Degree of protection	IP20
Class of protection	I, with PE connection
MTBF	> 500 000 h in acc. with IEC 61709 (SN 29500)
Type of housing	Steel sheet, zinc-plated
Side element version	Aluminum
Dimensions W / H / D (state of delivery)	60 mm / 130 mm / 152.5 mm
Weight	1.1 kg

Ambient conditions

Ambient temperature (operation)	-25 °C ... 70 °C (> 55° C derating)
Ambient temperature (storage/transport)	-40 °C ... 85 °C
Max. permissible relative humidity (operation)	95 % (at 25°C, no condensation)
Vibration (operation)	< 15 Hz, amplitude ±2.5 mm in acc. with IEC 60068-2-6 15 Hz ... 150 Hz, 2.3g, 90 min.
Shock	15g in all directions in acc. with IEC 60068-2-27
Pollution degree in acc. with EN 50178	2
Climatic class	3K3 (in acc. with EN 60721)

Standards

Electrical Equipment for Machinery	EN 60204 / Surge voltage category III
Safety transformers for power supply units	EN 61558-2-17
Electrical safety (of information technology equipment)	EN 60950/VDE 0805 (SELV) EN 61558-2-17
Electronic equipment for use in electrical power installations	EN 50178/VDE 0160 (PELV)
SELV	EN 60950 (SELV) EN 60204 (PELV)
Safe isolation	DIN VDE 0100-410 DIN VDE 0106-1010
Protection against electric shock	DIN 57100-410
Protection against electric shock, basic requirements for safe isolation in electrical equipment	DIN VDE 0106-101
Limitation of mains harmonic currents	EN 61000-3-2

Approvals

UL approvals	UL Listed UL 508 UL/C-UL Recognized UL 60950
--------------	---

Conformance with EMC directive 2004/108/EC**Noise immunity according to EN 61000-6-2**

Electrostatic discharge	EN 61000-4-2	
	Housing	Level 3
	Contact discharge	6 kV
	Discharge in air	8 kV
	Comments	Criterion B
Electromagnetic HF field	EN 61000-4-3	
	Housing	Level 3
	Frequency range	80 MHz ... 3 GHz
	Field intensity	10 V/m
	Comments	Criterion A
Fast transients (burst)	EN 61000-4-4	
	Input	4 kV (level 4 - asymmetrical: conductor to ground)
	Output	2 kV (level 3 - asymmetrical: conductor to ground)
	Comments	Criterion B
Surge current loads (surge)	EN 61000-4-5	
	Input	4 kV (level 4 - asymmetrical: conductor to ground) 2 kV (level 4 - symmetrical: conductor to conductor)
	Output	1 kV (Level 3 - symmetrical: Conductor to conductor) 2 kV (level 3 - asymmetrical: conductor to ground)
	Comments	Criterion B
Conducted interference	EN 61000-4-6	
	Input/output	Level 3 - asymmetrical
	Frequency range	10 kHz ... 80 MHz
	Voltage	10 V
	Comments	Criterion A
Voltage dips	EN 61000-4-11	
	Input	(mains buffering > 10 ms)
	Comments	Criterion B

Emitted interference in acc. with EN 61000-6-3

Radio interference voltage in acc. with EN 55011	EN 55011 (EN 55022) Class B, area of application: Industry and residential
Emitted radio interference in acc. with EN 55011	EN 55011 (EN 55022) Class B, area of application: Industry and residential

5 Structure

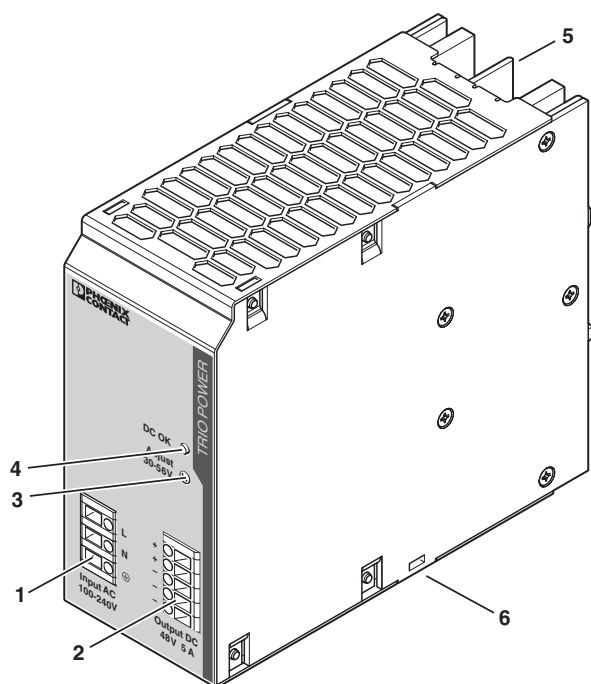

- 1 AC input
- 2 DC output
- 3 Potentiometer 30 V DC ... 56 V DC
- 4 "DC OK" LED
- 5 DIN rail adapter
- 6 Take-up for cable binders

	[mm ²]		AWG	[Nm] Torque
	solid	stranded		
Input	0.2 - 2.5	0.2 - 2.5	24 - 14	0.4 - 0.5
Output	0.2 - 2.5	0.2 - 2.5	24 - 14	0.4 - 0.5

Input data

Input nominal voltage range	100 V AC ... 240 V AC
AC input voltage range	85 V AC ... 264 V AC (derating < 90 V AC: 2.5% per Kelvin)
AC frequency range	45 Hz ... 65 Hz
Recommended backup fuse for mains protection	10 A (characteristic B) 16 A (characteristic B)
Type of connection	Screw connection
Stripping length	9 mm

Output data

Nominal output voltage	48 V DC \pm 1%
Setting range of the output voltage	30 V DC ... 56 V DC (> 48 V constant capacity)
Output current	5 A (-25°C ... 70°C)
Type of connection	Screw connection
Stripping length	9 mm

6 Block diagram

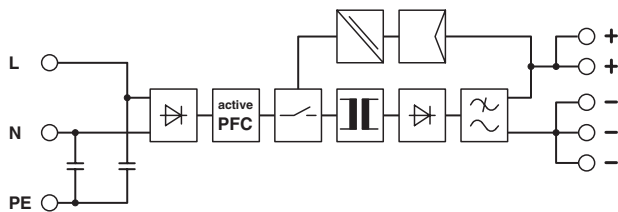

7 Safety notes



DANGER OF EXPLOSION!

Only remove equipment when it is disconnected and not in the potentially explosive area.

DANGER

Components with dangerously high voltage and high stored energy are located in the device!

Never carry out work on live parts!

Depending on the ambient temperature and the load, the housing can become very hot!



CAUTION

Before startup please ensure:

The mains connection has been carried out by a competent person and protection against electric shock is guaranteed!

The device can be disconnected outside the power supply unit in accordance with the regulations as in EN 60950 (e.g. through primary side line protection)!

The ground conductor is connected!

All feed lines are sufficiently protected and dimensioned!

All output lines are dimensioned according to the maximum output current of the device or separately protected!

Sufficient convection is guaranteed!



ATTENTION: Danger if used improperly

The power supply units are built-in devices. The device may only be installed and put into operation by qualified personnel. The corresponding national regulations must be observed.

8 Installation

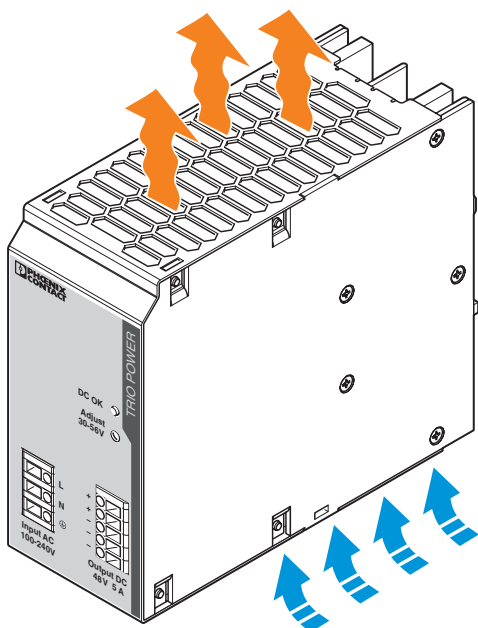

ATTENTION: Module can become damaged

In order to guarantee sufficient convection, we recommend observing the following minimum distance to other modules: 5 cm in a vertical direction and 0 cm in a horizontal direction.



The power supply unit can be snapped onto all DIN rails in acc. with EN 60715 and must be mounted vertically (connecting terminal blocks on bottom).

9 Installation position

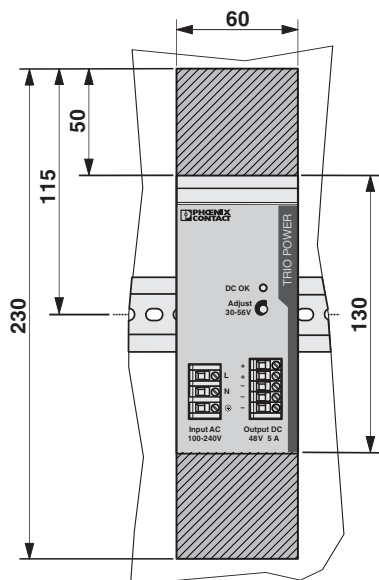

Mounting position: Installation depth 152.5 mm (+ DIN rail)

10 Mounting on DIN rails

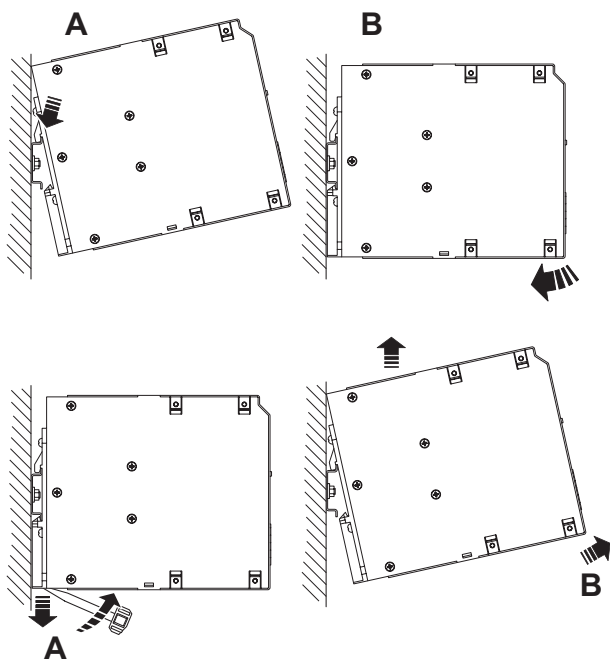

Assembly

Position the module with the DIN rail guide on the upper edge of the DIN rail, and snap it in with a downward motion.

Removing

Pull the snap lever open with the aid of a screwdriver and slide the module out at the lower edge of the DIN rail.

11 Connection to various systems

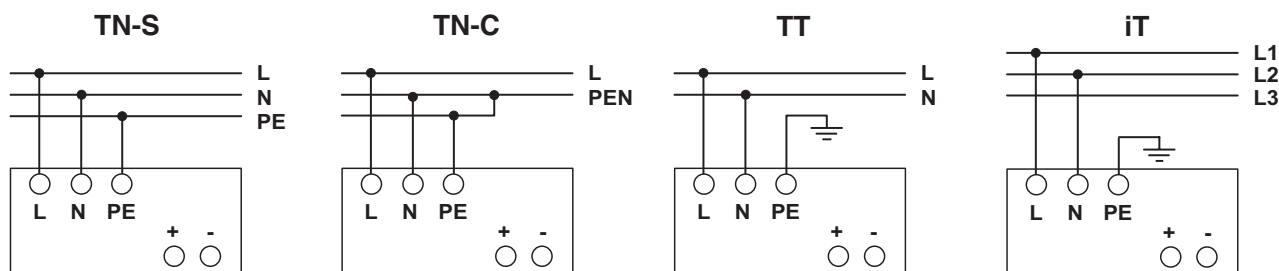

The 100 V AC ... 240 V AC connection is made using the L, N and PE screw connections.

The device can be connected to 1-phase AC systems or to two of the phase conductors of three-phase networks (TN, TT or iT system in acc. with VDE 0100-300/IEC 60364-3) with nominal voltages of 100 V AC ...240 V AC.

The device also continues to work on short-term input voltages > 300 V AC.

For operation on two of the phase conductors of a three-phase system, an isolating facility for all poles must be provided.



ATTENTION: Module can become damaged

In order to comply with the UL certification, use copper cables that are designed for operating temperatures of > 75°C.

In order to comply with EN 60950/UL 60950, flexible cables require ferrules. To safely connect a device, the ferrules should have a length of at least 10 mm. To achieve a reliable and shockproof connection, strip the connecting ends according to section "Structure".

12 Input

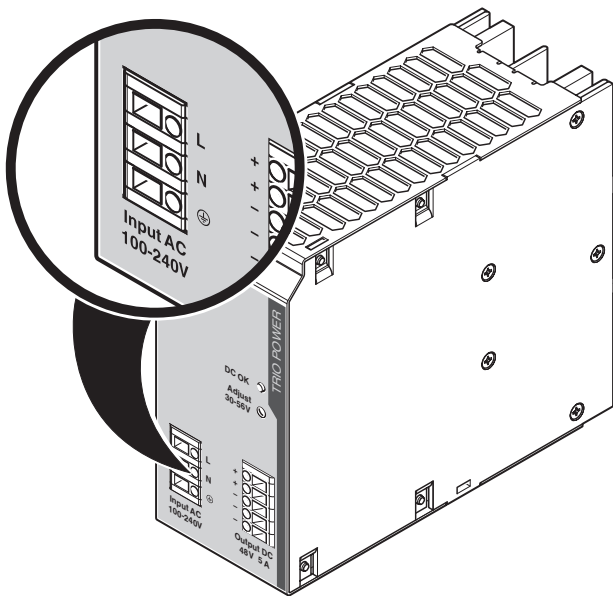

ATTENTION: Module can become damaged

If an external fuse is triggered, there is most probably a malfunction in the device. In this case, the device must be inspected in the factory!

The device must be installed in acc. with the regulations as in EN 60950. It must be possible to disconnect the device using a suitable isolating facility outside the power supply. Primary circuit mains protection, for example, is suitable for this purpose.

Recommended backup fuse for mains protection

Power circuit-breaker 10 A or 16 A, characteristic B (or identical function).

13 Output

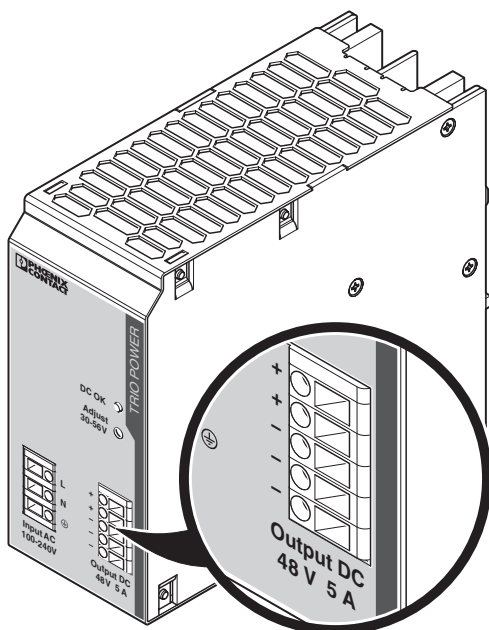

ATTENTION: Module can become damaged

Make sure that all output lines are dimensioned according to the maximum output current or are separately protected. The cables on the secondary side must have sufficiently large cross sections in order to keep the voltage drops on the lines as low as possible.



You can fasten the connection cables to the housing using cable binders. Ensure that the cable binders and the connection cables are designed for the surface temperatures that occur in operation. Make sure that the insulation of the connection cables is not damaged when tightening the cable binders.

The connection is made using the "+" and "-" screw connections on the screw connection of the DC output. The set output voltage is 48 V DC at the time of delivery. The output voltage can be set on the potentiometer.

Protection of the secondary side

The device is electronically protected against short circuit and idling. In the event of a malfunction, the output voltage is limited to 60 V DC.

14 Signaling

The "DC OK" LED enables evaluation of the function of the power supply directly on site.

	State 1	State 2
"DC OK" LED	ON	OFF
Cause	Output voltage > 0.9 x U _N	Output voltage > 0.9 x U _N or no voltage at output
Meaning	Output voltage and output current OK	The device is in operation, but there is a fault in the consumer, the current consumption is greater than I _N or the output is short circuited. The device is out of operation because there is no mains voltage, the fuse on the primary side has been triggered, or the device is faulty.

15 Function

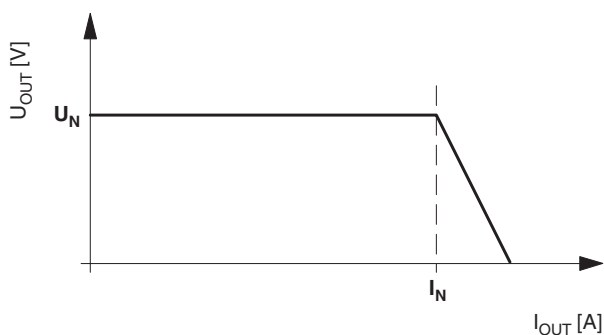

Output characteristic curve

The device functions following the U/I characteristic curve. Under load, the working point follows this curve. The output current is limited in the event of a short circuit or overload. Thereby, the device does not switch off, but rather supplies a continuous output current.

The secondary voltage is reduced until the short circuit or overload on the secondary side has been remedied. The U/I characteristic curve ensures that both heavily capacitive loads and loads with DC/DC converters in the primary circuit can be supplied. Downstream fuses are triggered. Selectivity in the design of your system is guaranteed at all times.

$$U_N = 48 \text{ V}$$

$$I_N = 5 \text{ A}$$

$$P_N = 240 \text{ W}$$

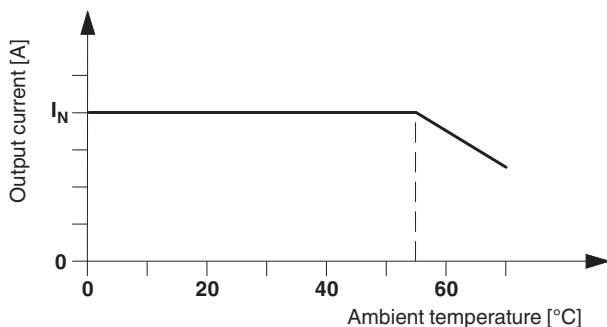

Thermal behavior

With an ambient temperature of up to +55°C, the device supplies the continuous output current of I_N . In the case of ambient temperatures above +55°C, the output current must be reduced by 2.5% per Kelvin increase in temperature. The device does not switch off at ambient temperatures of +70°C or thermal overload. The output capacity is reduced as far as necessary to provide device protection. After it has cooled down, the output capacity is increased again.

Parallel operation

Devices of the same type can be connected in parallel to enable both redundancy and an increase in efficiency. No other alignment is necessary when in the state of delivery. If the output voltage is adjusted, a uniform distribution of power is guaranteed by setting all parallel operated power supply units to exactly the same output voltage.

To ensure symmetrical distribution of power, we recommend designing all cable connections from the power supply unit to a busbar of the same length and with the same conductor cross section. The system makes it advisable to install a protective circuit at the output of each device when more than two power supply units are connected in parallel (e.g. decoupling diode or DC fuse). This prevents high reverse feed currents in the event of a secondary device fault.

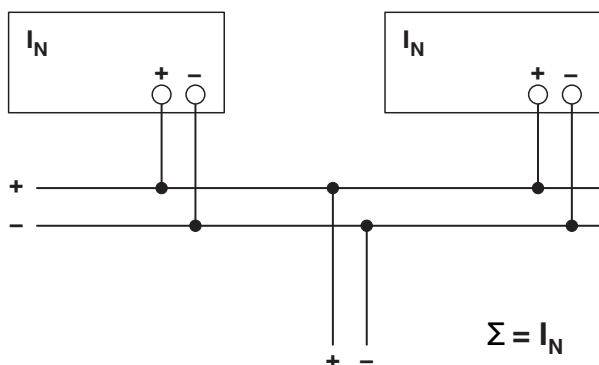

Redundant operation

Redundant circuits are suitable for the supply of systems which make especially high requirements on the operational safety. If a fault occurs in the primary circuit of the first power supply unit, the second device automatically takes over the entire power supply, without interruption, and vice versa. For this reason, the power supply units to be connected in parallel are dimensioned in such a way that the total current requirement of all consumers can be completely covered by one power supply unit. 100% redundancy makes external decoupling diodes necessary (QUINT-DIODE/40, Order No. 2938963)!

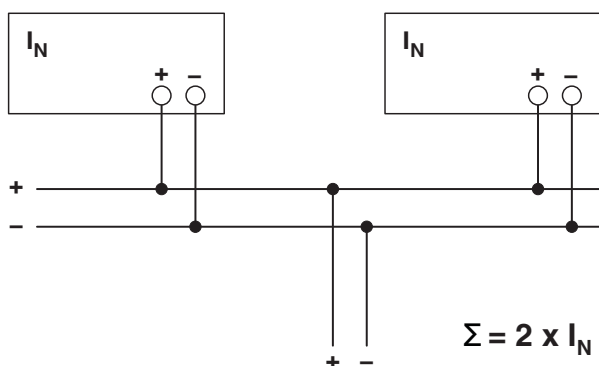

Increased performance

For n parallel connected devices, the output current can be increased to $n \times I_N$. Parallel connection to increase efficiency is used for the expansion of existing systems. It is advisable to use parallel connection if the power supply unit does not cover the current requirement of the most powerful consumer. Otherwise the consumers should be spread among individual devices independent of one another. A maximum of five devices can be connected in parallel!



SCATTERGOOD & JOHNSON LTD

ELECTRICAL ENGINEERING & FLUID CONTROL DISTRIBUTORS

Est.1899

At Scattergood & Johnson Ltd, we pride ourselves on being a technical distributor to specialist industries.

Working with a range of quality product suppliers across a number of specialist markets, we are not your average 'box shifter' - we are your technical and supply chain partner.

We fully support every product we sell - for free! Our internal team and external sales engineers can answer any product or application question, no matter the complexity.

Backing up this technical ability is a range of 50,000+ products available from stock for nationwide next day delivery (same day if required!), or you can collect what you need from any of our trade counters around the UK.

Select your specialist interest below to learn more about how we can help.



Online, In Branch and On the Road - Scattergood & Johnson Ltd, there when you need us.

www.scatts.co.uk