

# TRIO-DIODE/12-24DC/2X10/1X20

## Redundancy module

### INTERFACE

Data sheet  
104278\_en\_00

© PHOENIX CONTACT 2010-04-23



## 1 Description

TRIO DIODE is the DIN-rail mountable redundancy module from the TRIO POWER product range.

Using the redundancy module, it is possible for two power supply units of the same type connected in parallel on the output side to increase performance or for redundancy to be 100% isolated from one another.

Redundant systems are used in systems that place particularly high demands on operational reliability. The connected power supply units must be large enough that the total current requirements of all loads can be met by one power supply unit. The redundant structure of the power supply therefore ensures long-term, permanent system availability.

In the event of an internal device fault or failure of the mains power supply on the primary side, the other device automatically takes over the entire power supply of the loads without interruption. The floating signal contact and LED immediately indicate the loss of redundancy.

## Features

- 100% decoupling of power supply units connected in parallel
- Reliable signaling of redundancy
- Load currents up to 30 A supported
- Easy, space-saving DIN rail mounting
- High level of safety with regard to supply due to MTBF > 10 million h
- Reverse polarity protection



Make sure you always use the latest documentation.  
It can be downloaded from the product at [www.phoenixcontact.net/catalog](http://www.phoenixcontact.net/catalog).

**2 Table of contents****2 Table of Contents**

1	Description .....	1
	Features.....	1
2	Table of contents.....	2
3	Ordering data .....	3
4	Technical data.....	3
5	Structure.....	5
6	Block diagram .....	6
7	Safety and warning notes .....	6
8	Installation .....	7
9	Installation position.....	7
10	Mounting on DIN rails .....	8
	Assembly .....	8
	Removing.....	8
11	Input .....	8
12	Output .....	9
13	Function .....	9
	Input/output.....	9
	Signaling .....	10
	Thermal behavior .....	10

### 3 Ordering data

Description	Type	Order No.	Pcs. / Pkt.
Redundancy module with function monitoring, 12-24 V DC, 2x 10 A, 1x 20 A	TRIO-DIODE/12-24DC/2X10/1X20	2866514	1

### 4 Technical data

Input data/output data	
Input nominal voltage range	12 V DC ... 24 V DC
DC input voltage range	10 V DC ... 30 V DC
Voltage drop, input/output	Approx. 0.5 V
Nominal current	2x 10 A (-25°C to +55°C) 1x 20 A (-25°C to +55°C)
Maximum current	2x 15 A (-25°C to +40°C) 1x 30 A (-25°C to +40°C)
Derating	From +55°C to 70°C: 2.5% per Kelvin
Efficiency	> 97 %
Transient surge protection	Varistor
Protection against polarity reversal	Yes, with integrated diode, < 60 V
Power consumption	
Power loss nominal load max.	Approx. 10 W
Floating redundancy OK	
Output description	Contact closed when $U_{IN1}$ & $U_{IN2} > 8$ V
Voltage	+ 60 V DC
Current	≤ 100 mA (short circuit resistant)
Status display	LED redundancy OK / $U_{IN1}$ & $U_{IN2} > 8$ V: LED lights up green
General data	
Insulation voltage input / PE	500 V
Insulation voltage output / PE	500 V
Degree of protection	IP20
Class of protection	III, without PE connection
MTBF	> 10000000 h
Type of housing	Steel sheet, zinc-plated
Side element version	Aluminum
Dimensions W / H / D (state of delivery)	32 mm / 130 mm / 115 mm
Weight	0.37 kg
Ambient conditions	
Ambient temperature (operation)	-25 °C ... 70 °C (> 55°C derating)
Ambient temperature (storage/transport)	-40 °C ... 85 °C
Max. permissible relative humidity (operation)	≤ 95 % (at 25 °C, no condensation)
Vibration (operation)	< 15 Hz, amplitude ±2.5 mm 15 Hz ... 150 Hz, 2.3g, 90 min.
Shock	15g in all directions in acc. with IEC 60068-2-27
Pollution degree in acc. with EN 50178	2
Climatic class	3K3 (in acc. with EN 60721)

**Standards**

Electrical Equipment for Machinery	EN 60204
Electrical safety (of information technology equipment)	EN 60950/VDE 0805 (SELV)
Electronic equipment for use in electrical power installations	EN 50178/VDE 0160 (PELV)
SELV	IEC 60950 (SELV) and EN 60204 (PELV)
Safe isolation	DIN VDE 0100-410 DIN VDE 0106-1010
Protection against electric shock	DIN 57100-410
Protection against electric shock, basic requirements for safe isolation in electrical equipment	DIN VDE 0106-101

**Approvals**

UL approvals	UL/C-UL listed UL 508 UL/C-UL Recognized UL 60950
--------------	--



Current approvals can be found for the product in the download area.

**Conformance with EMC guideline 2004/108/EC and for low-voltage guideline 2006/95/EC****Noise immunity according to EN 61000-6-2**

Electrostatic discharge	EN 61000-4-2	
	Housing	Level 3
	Contact discharge	6 kV (Contact discharge)
	Discharge in air	8 kV (Air discharge)
Electromagnetic HF field	EN 61000-4-3	
	Housing	Level 3
	Frequency range	80 MHz ... 3 GHz
	Field intensity	10 V/m
Fast transients (burst)	EN 61000-4-4	
	Input	2 kV (level 3 - asymmetrical: conductor to ground)
	Output	2 kV (level 3 - asymmetrical: conductor to ground)
	Comments	Criterion B
Surge current loads (surge)	EN 61000-4-5	
	Input	2 kV (level 3 - asymmetrical: conductor to ground) 1 kV (Level 2 - symmetrical: Conductor to conductor)
	Output	2 kV (level 3 - asymmetrical: conductor to ground) 1 kV (Level 2 - symmetrical: Conductor to conductor)
	Comments	Criterion B
Conducted interference	EN 61000-4-6	
	Input/output	Level 3
	Frequency range	150 kHz ... 80 MHz
	Voltage	10 V
	Comments	Criterion A

**Emitted interference in acc. with EN 61000-6-3**

Radio interference voltage in acc. with EN 55011	EN 55011 (EN 55022) Class B, area of application: Industry and residential
Emitted radio interference in acc. with EN 55011	EN 55011 (EN 55022) Class B, area of application: Industry and residential

## 5 Structure

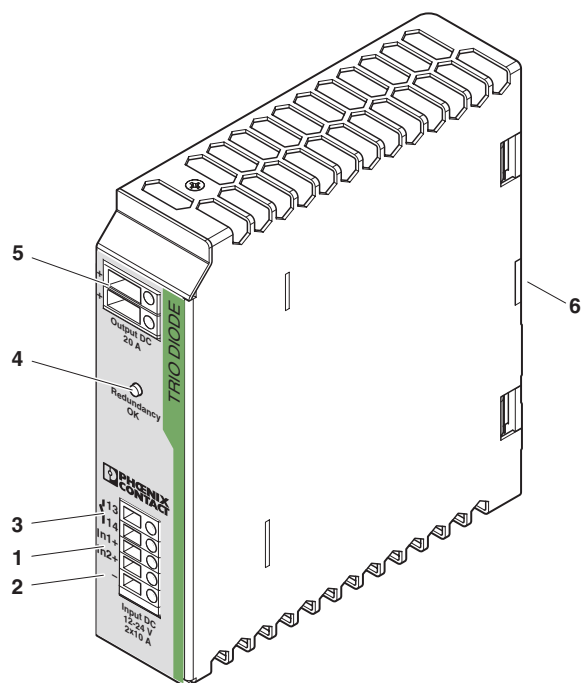

- 1 DC input In1/In2:  
Input voltage 12 ... 24 V,  $I_N = 2 \times 10 \text{ A}$
- 2 GND signal
- 3 Floating relay contact  
(maximum 60 V, 100 mA, short-circuit-proof)
- 4 "Redundancy OK" LED, green
- 5 DC output approximately  $0.5 \text{ V} < \text{DC input}$
- 6 Universal snap-on foot for EN DIN rails

	[mm <sup>2</sup> ]		AWG	[Nm] Torque
	solid	stranded		
Input	0.2 - 2.5	0.2 - 2.5	24 - 14	0.4 - 0.5
Output	0.5 - 6	0.5 - 4	20 - 10	0.5 - 0.6
Signal	0.2 - 2.5	0.2 - 2.5	24 - 14	0.4 - 0.5

### Input data

Input nominal voltage range	12 V DC ... 24 V DC
DC input voltage range	10 V DC ... 30 V DC
Type of connection	Screw connection
Stripping length	9 mm

### Output data

Nominal output voltage	$0.5 \text{ V} < \text{DC input}$
Type of connection	Screw connection
Stripping length	14 mm

## 6 Block diagram

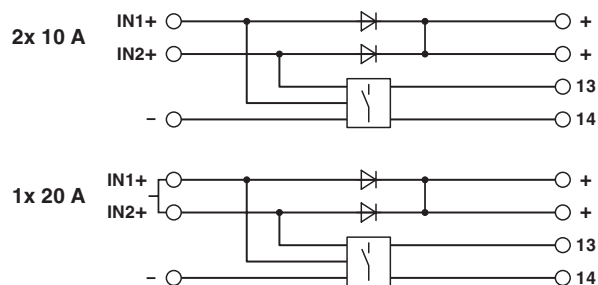

## 7 Safety and warning notes



The redundancy modules are built-in devices. Installation and startup must only be carried out by qualified personnel. The country-specific regulations (e.g., VDE, DIN) must be observed.



### Danger

Never carry out work when the power is turned on.

Depending on the ambient temperature and the load, the housing can become very hot.



### CAUTION

Before startup please ensure:

The connection must be carried out by a competent person and protection against electric shock guaranteed. All input and output lines are dimensioned according to the maximum output current of the device or separately protected.

Sufficient convection must be guaranteed.

## 8 Installation

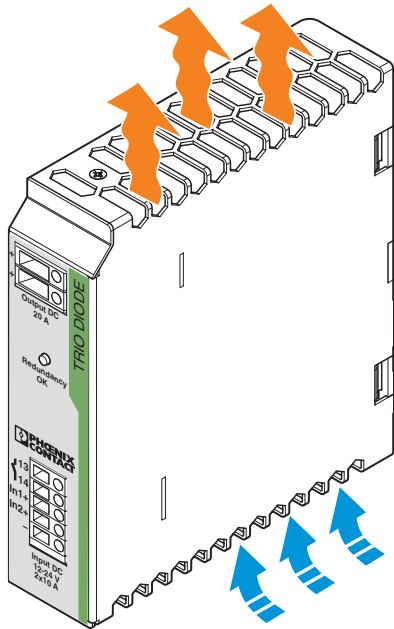

### ATTENTION

To ensure sufficient convection, we recommend the following minimum spacing be used between modules: 5 cm for vertical installation and 0 cm for horizontal installation.



The redundancy module can be snapped onto all DIN rails in accordance with EN 60715 and must be mounted horizontally (connecting terminal blocks on top and bottom).

## 9 Installation position

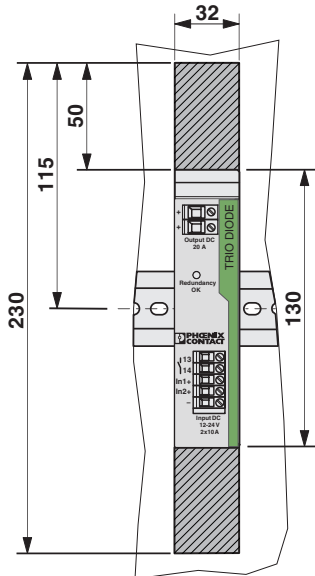

Mounting position: Installation depth 115 mm (+ DIN rail)

## 10 Mounting on DIN rails

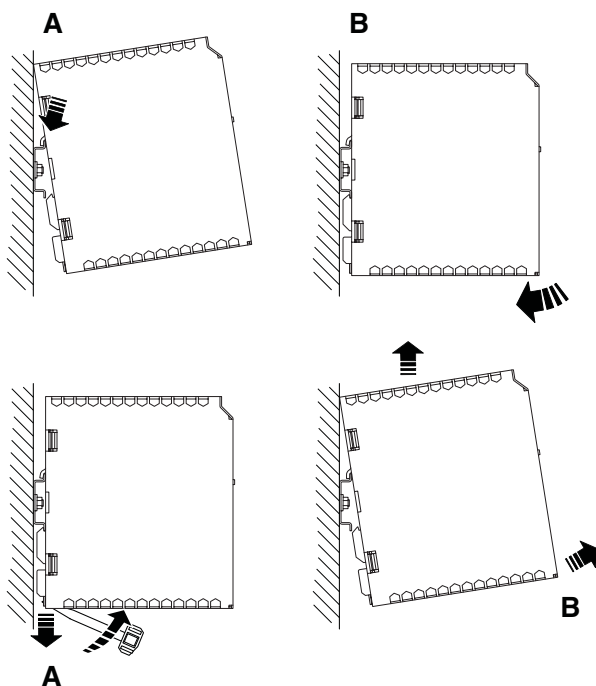

### Assembly

Position the module with the DIN rail guide on the upper edge of the DIN rail, and snap it in with a downward motion.

### Removing

Pull the snap lever open with the aid of a screwdriver and slide the module out at the lower edge of the DIN rail.

## 11 Input

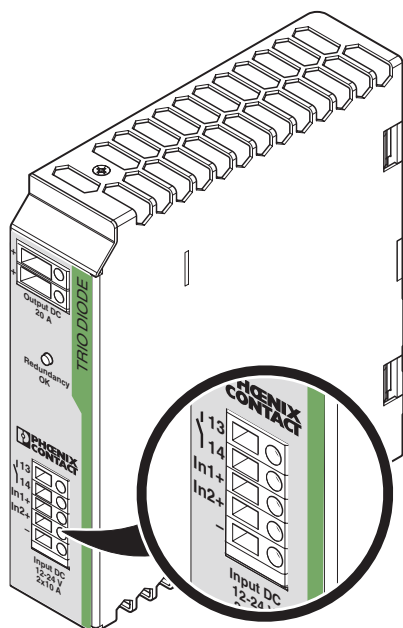

You can fasten the connection cables to the housing using cable binders.

Make sure that the connecting cables and cable binders used are designed for the surface temperatures on the housing.

When tightening the cable binders, the insulation of the connecting cables must not be damaged.

Connection of the input is made via connection terminal blocks "In1+" and "In2+". The "-" terminal is then only connected when signaling is necessary.

## 12 Output

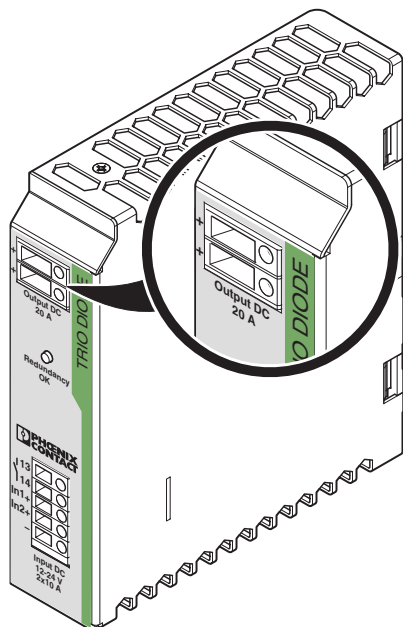

The output is connected via the internally connected "+" terminals.

## 13 Function

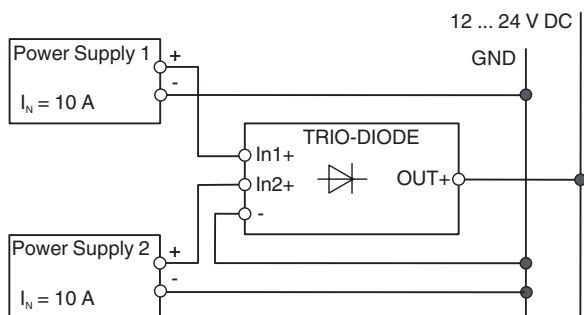

### Input/output

To decouple two parallel connected power supplies 1 and 2 with nominal currents of up to 10 A, one redundancy module is necessary.

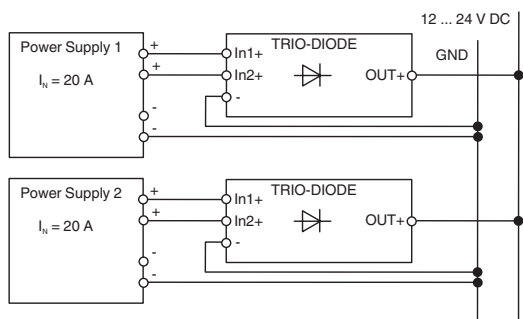

One redundancy module per power supply is required to decouple power supplies with nominal currents from 10 A to 20 A. Inputs "In1+" and "In2+" of the redundancy module must be connected to the power supply unit using two conductors. This is necessary because the maximum current carrying capacity of 15 A per input must not be exceeded. For connecting the redundancy module to the power supply unit, we recommend using two identical connecting cables (cable length/cable cross sections).

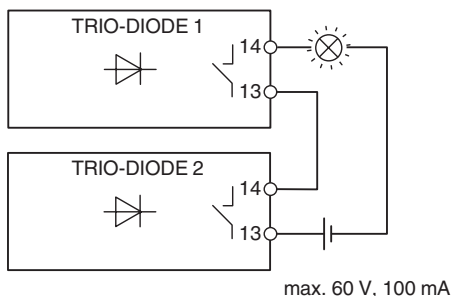
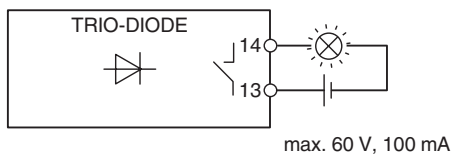

### Signaling

A floating relay contact and "Redundancy OK" LED are available for monitoring redundancy. In normal operation where input voltage > 8 V DC at input terminals "IN1+" and "IN2+", the relay contact (13/14) is closed and the "Redundancy OK" LED lights up. If the input voltage falls to below the value of 8 V DC at one of the input terminals, the floating relay contact opens and the "Redundancy OK" LED goes out.

Floating, current-limited "Redundancy OK" signal contacts are to be connected in series for monitoring redundancy. If monitoring the redundancy is not necessary, the "GND signal" does not need to be connected.

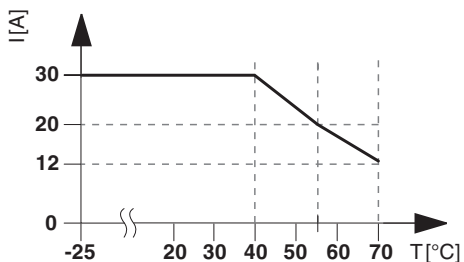

### Thermal behavior

The device can be operated at an ambient temperature of -25 °C to +70 °C. For ambient temperatures above +55, the output current must be reduced by 2.5% per Kelvin increase in temperature.



# SCATTERGOOD & JOHNSON LTD

ELECTRICAL ENGINEERING & FLUID CONTROL DISTRIBUTORS

Est.1899

At Scattergood & Johnson Ltd, we pride ourselves on being a technical distributor to specialist industries.

Working with a range of quality product suppliers across a number of specialist markets, we are not your average 'box shifter' - we are your technical and supply chain partner.

We fully support every product we sell - for free! Our internal team and external sales engineers can answer any product or application question, no matter the complexity.

Backing up this technical ability is a range of 50,000+ products available from stock for nationwide next day delivery (same day if required!), or you can collect what you need from any of our trade counters around the UK.

Select your specialist interest below to learn more about how we can help.

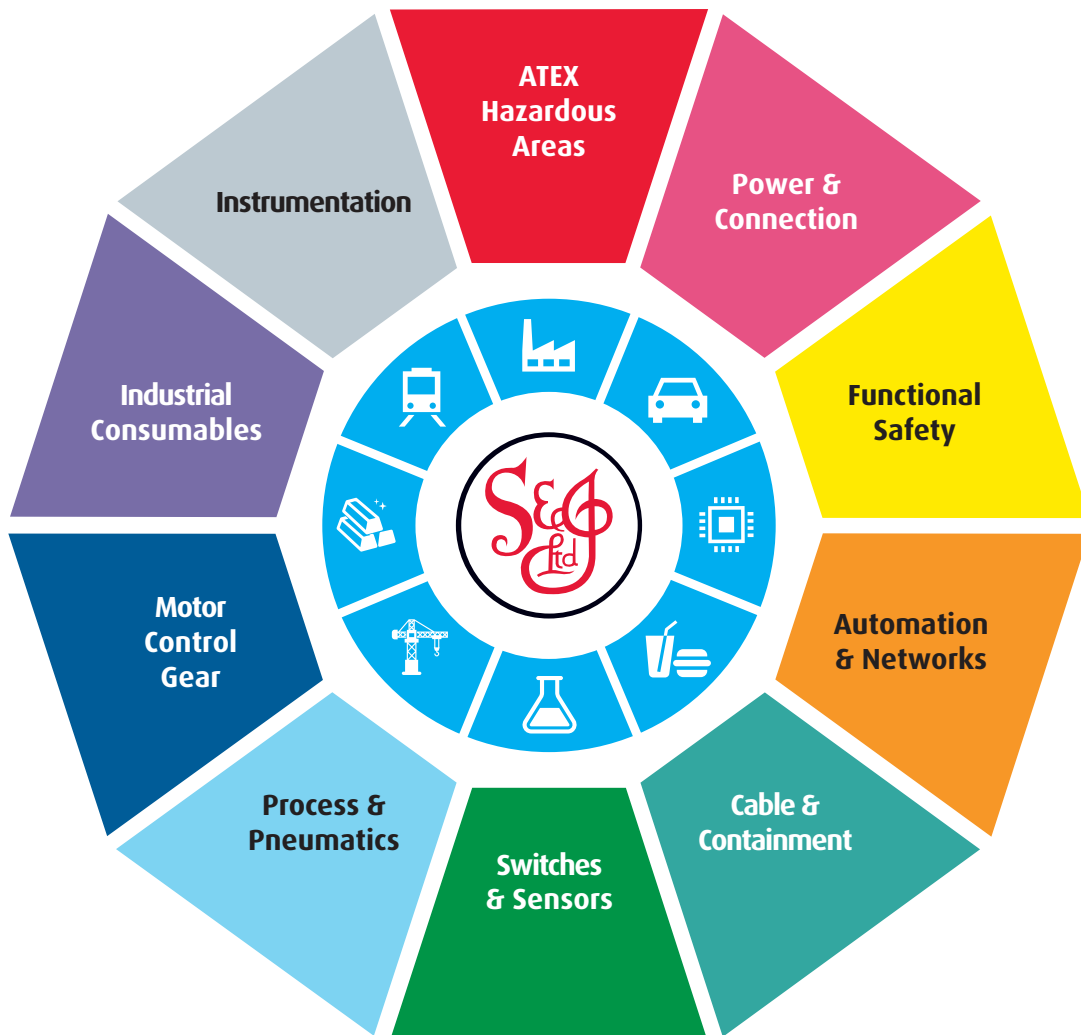

Online, In Branch and On the Road - Scattergood & Johnson Ltd, there when you need us.

# [www.scatts.co.uk](http://www.scatts.co.uk)