

MINI-PS-100-240AC/24DC/1.5/EX

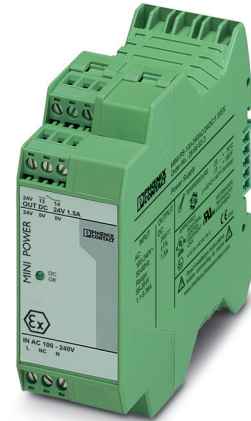

**Power supply unit, primary switched-mode,
for use in potentially hazardous areas**



INTERFACE

Data Sheet
103074_en_01

© PHOENIX CONTACT 2015-12-10

Description

MINI POWER is the extremely slim power supply unit with constructional widths of 22.5 mm, 35 mm, 45 mm and 67.5 mm.

In addition to a 24 V version with output currents of 1.3 A, 2 A and 4 A, special voltages with 5 V/3 A and ± 15 V/1 A and 10 V...15 V/2 A and 8 A are also available.

The DIN rail connectors of the MINI-PS-100-240AC/24DC/1.5/EX allow additional modules of the same system to be supplied with a regulated 24 V DC voltage by parallel contacting. A reliable starting of complex loads is ensured by a power reserve of up to 100% – the POWER BOOST.

The high operational reliability is thus dependably guaranteed in complex global networks as well. MINI POWER also functions in applications where static voltage dips, transient failures of the supply voltage or phase failure are to be expected.

Generously dimensioned capacitors guarantee a mains buffering of more than 20 ms under full load.

Area of application

The power supply unit complies with standard EN 60079-15 and may be installed within the potentially hazardous area in which category 3G electrical apparatus is necessary.

Worldwide use is realized by the consistent implementation of a wide-range input.

In this way, your whole system can be tested at any manufacturing location in the world and be delivered to global destinations without switching over the input voltage, often a source of faults. This saves storage costs and reduces the logistical work.

An international approval package including UL 60950 for information technology equipment and UL 508 for industrial regulating devices pave the way for worldwide applications.



Danger!

**Components with dangerously high voltage and high stored energy are located in the device!
Never carry out work on live parts!
Depending on the ambient temperature and the load, the housing can become very hot!**



Make sure you always use the the latest documentation.
It can be downloaded at www.download.phoenixcontact.com.

A conversion table is available on the Internet at
www.download.phoenixcontact.com/general/7000_en_00.pdf.

MINI-PS-100-240AC/24DC/1.5/EX

Order data

Description	Type	Order No.	Pcs./Pkt.
Power supply unit, primary switched-mode, for use in potentially hazardous areas	MINI-PS-100-240AC/24DC/1.5/EX	2866653	1

Accessories	Type	Order No.	Pcs./Pkt.
Bus connector, gold-plated contacts, for mounting on DIN rail, 5-pos.	ME 17,5 TBUS 1,5/ 5-ST-3,81 GN	2709561	10

Technical data

Input data	
Input nominal voltage range	100 V AC ... 240 V AC (wide-range input)
AC input voltage range	85 V AC ... 264 V AC
AC frequency range	45 Hz ... 65 Hz
Current consumption	Approx. 0.75 A (120 V AC) Approx. 0.45 A (230 V AC)
Inrush current limitation/ I^2t	< 15 A (0.6 A ² s)
Power failure bypass	> 35 ms (120 V AC) > 150 ms (230 V AC)
Typical response time	< 0.5 s
Protective circuitry	Transient surge protection, varistor
Input fuse, integrated	3.15 A (slow-blow, internal)
Recommended backup fuse for mains protection	6 A (power circuit-breaker, characteristic B) 10 A (power circuit-breaker, characteristic B) 16 A (power circuit-breaker, characteristic B)

Output data	
Nominal output voltage	24 V DC \pm 1%
Output current	1.5 A (up to 60°C) 2 A (with POWER BOOST)
Derating	From +60°C 2.5% per Kelvin
Output current limit	7 A (in the event of a short circuit)
Max. capacitive load	Unlimited
Control deviation	< 1 % (change in load, static 10% ... 90%) < 3 % (change in load, dynamic 10% ... 90%) < 0.1 % (change in input voltage \pm 10%)
Power loss nominal load max.	6.5 W
Maximum power dissipation idling	1.5 W
Efficiency	> 84 % (for 230 V AC and nominal values)
Ascent time	< 2 ms
Residual ripple	< 40 mV _{SS} (20 MHz)
Peak switching voltages	< 20 mV _{SS} (20 MHz)
Connection in parallel	Yes, for redundancy and increased capacity. Maximum of 2 devices for redundancy on DIN rail connector.
Surge protection against internal surge voltages	Yes, < 30 V DC
Resistance to reverse feed	35 V DC

MINI-PS-100-240AC/24DC/1.5/EX**Signal output DC OK floating**

Output description	$U_{OUT} > 21.5 \text{ V}$: Contact closed
Continuous current	1 A
Output voltage	30 V AC/DC
Status display	LED green ($U_{out} > 21,5 \text{ V DC}$: LED permanently lit)

Standards

Electrical Equipment for Machinery	EN 60204-1
Electrical safety (of information technology equipment)	EN 60950/VDE 0805 (SELV) UL/C-UL recognized UL 60950
Industrial control equipment	UL/C-UL Listed UL 508
Electronic equipment for use in electrical power installations	EN 50178/VDE 0160 (PELV)
SELV	EN 60950 (SELV) and EN 60204-1 (PELV)
Safe isolation	DIN VDE 0100-410
Limitation of mains harmonic currents	EN 61000-3-2

Approvals

Granted approvals	
Granted approvals for potentially explosive areas	ATEX  II 3G Ex nA nC IIC T4 X

General data

Insulation voltage input/output	3 kV (routine test) 4 kV (type test)
Installation position	On horizontal DIN rail NS 35 in acc. with EN 60715
Degree of protection	IP20
Class of protection	II (in an enclosed control cabinet)
MTBF	> 2789000 h in acc. with IEC 61709 (SN 29500)
Housing version	Polyamide PA, color: green
Width	35 mm
Height	99 mm
Depth	95 mm
Weight	0.25 kg

Climatic data

Ambient temperature (operation)	-25 °C ... 70 °C (> 60°C Derating: 2.5 %/K)
Ambient temperature (storage/transport)	-40 °C ... 85 °C
Max. permissible. relative humidity (operation)	100 % (at 25°C, no condensation)
Vibration (operation)	< 15 Hz, amplitude $\pm 2.5 \text{ mm}$ in acc. with IEC 60068-2-6 15 Hz ... 150 Hz, 2.3g, 90 min.
Shock	30g in all directions in acc. with IEC 60068-2-27
Pollution degree in acc. with EN 50178	2
Climatic class	3K3 (in acc. with EN 60721)

Conformance with EMC directive 89/336/EEC**Immunity to interference in acc. with EN 61000-6-2**

Discharge of static electricity in acc. with EN 61000-4-2

	Housing	Level 3
	Contact discharge	6 kV
	Discharge in air	8 kV
	Comments	Criterion B

Electromagnetic HF field in acc. with EN 61000-4-3

	Housing	Level 3
	Frequency range	80 MHz ... 2 GHz
	Field intensity	10 V/m
	Comments	Criterion A

Fast transients (burst) in acc. with EN 61000-4-4

	Input	4 kV (level 4 - asymmetrical: conductor to ground)
	Output	2 kV (level 3 - asymmetrical: conductor to ground)
	Signal	1 kV (level 2 - asymmetrical: conductor to ground)
	Comments	Criterion B

Surge voltage capacities (surge) in acc. with EN 61000-4-5

	Input	4 kV (level 4 - asymmetrical: conductor to ground)
		2 kV (level 3 - symmetrical: conductor to conductor)
	Output	1 kV (level 2 - asymmetrical: conductor to ground)
		0.5 kV (level 1 - symmetrical: conductor to conductor)
	Signal	0.5 kV (level 1 - asymmetrical: conductor to ground)
	Comments	Criterion B

Conducted disturbance in acc. with EN 61000-4-6

	Input/Output/Signal	Level 3 - asymmetrical
	Frequency range	0.15 MHz ... 80 MHz
	Voltage	10 V
	Comments	Criterion A

Voltage dips in acc. with EN 61000-4-11

	Input	(mains buffering > 20 ms)
	Comments	Criterion B

Emitted interference in acc. with EN 61000-6-3

Radio interference voltage in acc. with EN 55011 EN 55011 (EN 55022) Class B, area of application: Industry and residential

Emitted radio interference in acc. with EN 55011 EN 55011 (EN 55022) Class B, area of application: Industry and residential

Note:

Criterion A: Normal operating behavior within the defined limits.

Criterion B: Temporary impairment to operational behavior that is corrected by the device itself

Block diagram

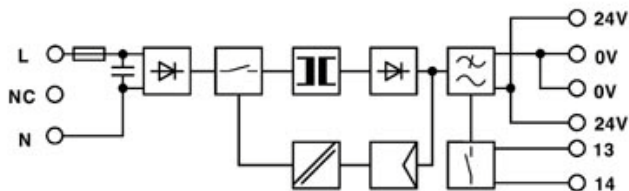

Structure

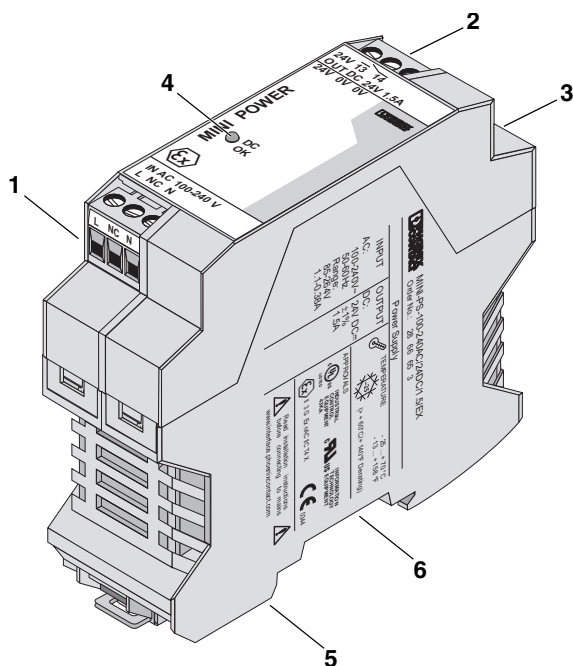

- 1 AC input
- 2 DC output
- 3 DC OK output, floating
- 4 DC OK control lamp
- 5 Universal snap-on foot: 35 mm DIN rail according to EN 60715
- 6 Connection option for DIN rail connector



The power supply unit complies with standard EN 60079-15 and may be installed within the potentially hazardous area in which category 3G electrical apparatus is necessary.

	[mm ²]		AWG	[Nm] Torque
	solid	stranded		
Input	0.2 - 2.5	0.2 - 2.5	24 - 12	0.5 - 0.6
Output	0.2 - 2.5	0.2 - 2.5	24 - 12	0.5 - 0.6
Signal	0.2 - 2.5	0.2 - 2.5	24 - 12	0.5 - 0.6

Input data	
Input nominal voltage range	100 V AC ... 240 V AC (wide-range input)
AC input voltage range	85 V AC ... 264 V AC
AC frequency range	45 Hz ... 65 Hz
Input fuse, integrated	3.15 A (slow-blow, internal)
Recommended backup fuse for mains protection	6 A (power circuit-breaker, characteristic B) 10 A (power circuit-breaker, characteristic B) 16 A (power circuit-breaker, characteristic B)
Type of connection	COMBICON screw/plug connection
Stripping length	7 mm
Output data	
Nominal output voltage	24 V DC ±1%
Output current	1.5 A (up to 60°C) 2 A (with POWER BOOST)
Type of connection	COMBICON screw/plug connection
Stripping length	7 mm

Safety and warning notes



The power supply units are built-in devices. The device may only be installed and put into operation by qualified personnel. The corresponding national regulations (e.g. VDE, DIN) must be observed.



Danger!

**Components with dangerously high voltage and high stored energy are located in the device!
Never carry out work on live parts!
Depending on the ambient temperature and the load, the housing can become very hot!**



Before startup please ensure:

The mains connection has been carried out by a competent person and protection against electric shock is guaranteed!

The device can be disconnected outside the power supply unit in accordance with the regulations as in EN 60950 (e.g. through primary side line protection)!

All feed lines are sufficiently protected and dimensioned!

All output lines are dimensioned according to the maximum output current of the device or separately protected!

Sufficient convection is guaranteed!

Cables may only be snapped on or connected in potentially explosive areas when the power is disconnected.

The device is a category 3 item of electrical equipment. Follow the instructions provided during installation. The device must be installed in housing with IP54 protection according to EN 60529. The specified limits for mechanical strain or thermal loads for the device must not be exceeded. Only devices suitable for operation in the potentially explosive areas of zone 2 may be connected. Repairs must not be carried out by the user.

Installation

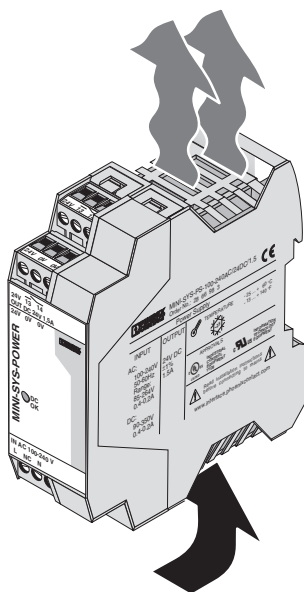

In order to guarantee sufficient convection, we recommend observing the following minimum distance to other modules: 5 cm in a vertical direction and 0 cm in a horizontal direction.



The power supply unit can be snapped onto all DIN rails in acc. with EN 60715. They must be horizontal (connecting terminal blocks above and below).

Installation position

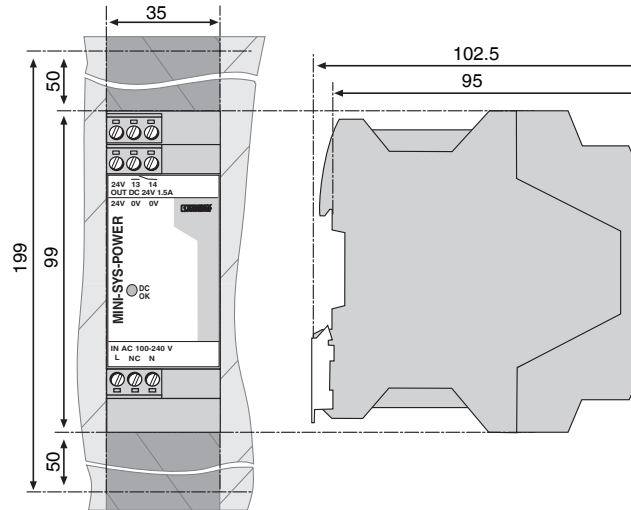

Installation: Installation depth 95 mm (+ DIN rail)

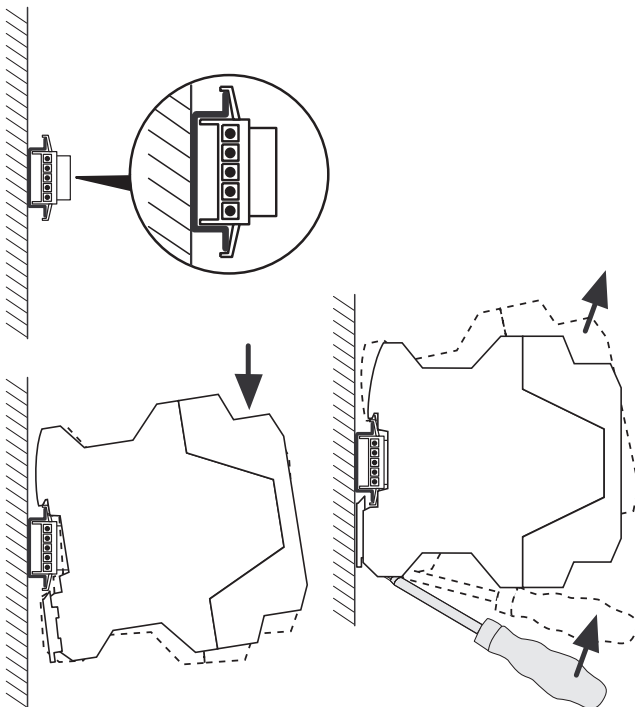

Assembly

When the DIN rail connector ME 17,5 TBUS (Order no. 2709561, 2x required) is used, place this in the DIN rail first.

Position the module with the DIN rail guide on the upper edge of the DIN rail, and snap it in with a downward motion.

Dismantling

Pull the snap lever open with the aid of a screwdriver and slide the module out at the lower edge of the DIN rail.

Connection, network forms 100...240 V AC networks

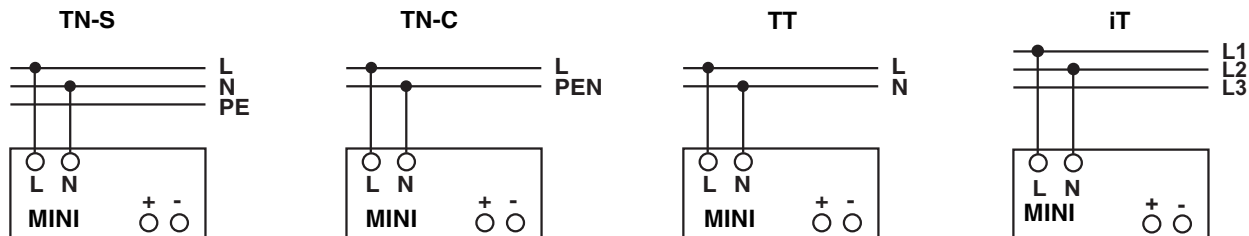

The 100...240 V AC connection is made using the L and N screw connections.

The device can be connected to 1-phase AC systems or to two of the phase conductors of three-phase systems (TN, TT or IT networks in acc. with VDE 0100-300/IEC 60364-3) with nominal voltages of 100 V AC ...240 V AC.



For operation on two of the phase conductors of a three-phase system, an isolating facility for all poles must be provided.

Input

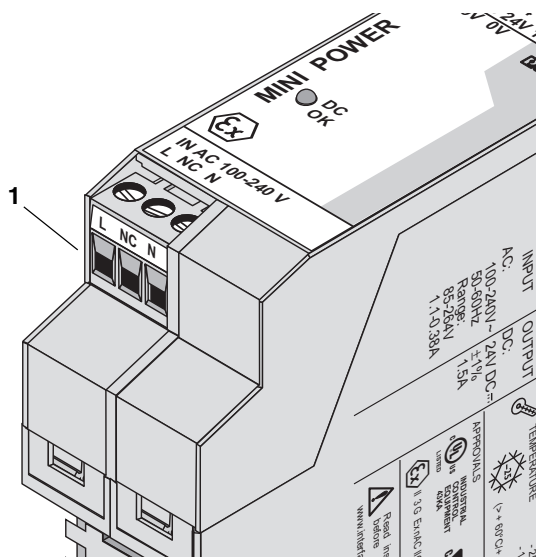

Protection of the primary side

The device must be installed in acc. with the regulations as in EN 60950. It must be possible to disconnect the device using a suitable isolating facility outside the power supply. The primary side line protection, for example, is suitable. For device protection, there is an internal fuse. Additional device protection is not necessary.

Recommended backup fuse for mains protection

Power circuit-breaker 6 A, 10 A or 16 A, characteristic B (or identical function).



If an internal fuse is triggered, there is most probably a malfunction in the device. In this case, the device must be inspected in the factory! The power supply unit cannot be repaired by the user and must be replaced by an equivalent.

Output

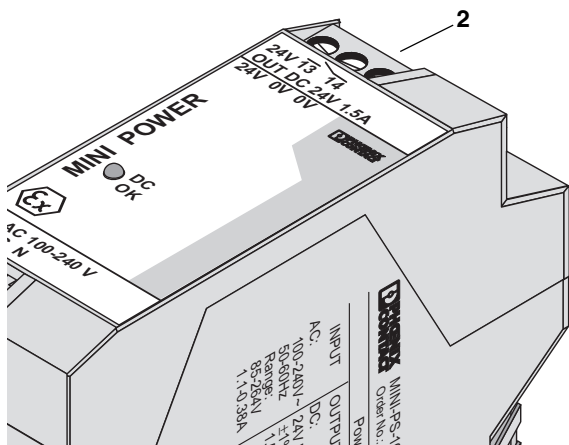

Make sure that all output lines are dimensioned according to the maximum output current or are separately protected. The cables on the secondary side must have sufficiently large cross sections in order to keep the voltage drops on the lines as low as possible.

They are connected using the "24 V" and "0 V" screw connections on the screw connection of the DC output and via the DIN rail connector.

Only devices which are suitable for operation in potentially explosive areas of zone 2 may be connected to the output voltage in zone 2.

Protection of the secondary side

The device is electronically protected against short circuit and idling. In the event of a malfunction, the output voltage is limited to 30 V DC. External decoupling diodes are required for redundancy operation of these power supplies.

Signaling

For function monitoring, there is the floating DC OK switching output and the DC OK LED.

	State 1	State 2
DC OK LED	ON	OFF
Floating DC OK output	Closed	Open
Meaning	Normal operation of the power supply ($U_{OUT} > 21.5 \text{ V}$)	1. The output voltage is less than 21.5 V. There is a secondary consumer short circuit or overload. 2. There is no input voltage or there is a device fault.

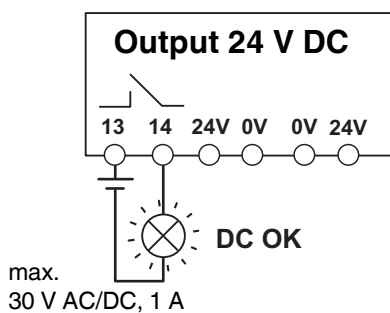

Floating contact

The floating signal contact opens and signalizes a drop in the output voltage by more than 10%. Signals and ohmic loads of up to 30 V and currents of up to 1 A can be connected. For heavily inductive loads such as a relay, a suitable protection circuit (e.g. damping diode) is necessary.

Function

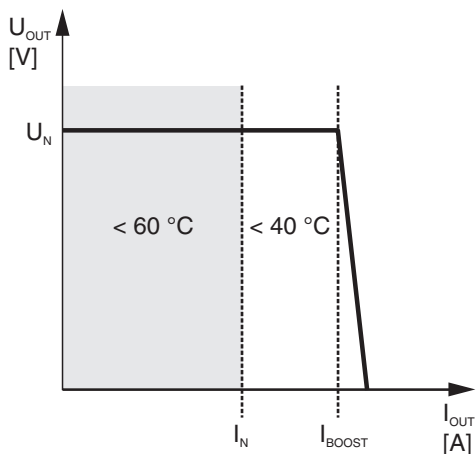

Output characteristic curve

The device can supply a nominal output current of 1.5 A with ambient temperatures of up to 60°C. At an ambient temperature of up to 40°C, the device supplies a continuous output current of 2 A. At temperatures up to 60°C, the POWER BOOST provides a transient output current of 2 A for a few minutes. In the event of a higher load, the operating point follows the U/I characteristic curve depicted in the figure.

In the case of overload or short-circuit, the full output current I_{BOOST} is supplied permanently with reduced output voltage, the device does not switch off. As soon as the overload or short-circuit is no longer present, the full secondary voltage is once again available.

The U/I characteristic curve ensures that both heavily capacitive loads and devices with DC/DC converters in the primary circuit can be fed without problems using MINI POWER.

Downstream fuses are triggered reliably. Selectivity in the design of your system is guaranteed at all times.

$$U_N = 24 \text{ V}$$

$$I_N = 1.5 \text{ A}$$

$$I_{BOOST} = 2 \text{ A}$$

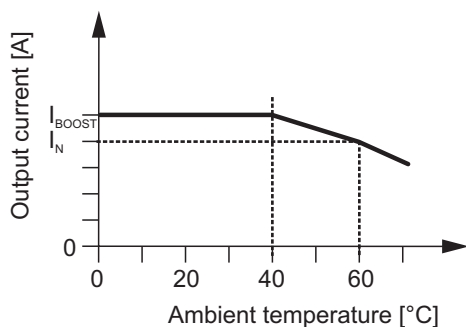

Thermal behavior

The device can supply a nominal output current of 1.5 A with ambient temperatures of up to 60°C. At an ambient temperature of up to 40°C, the device supplies a continuous output current of 2 A. At temperatures up to 60°C, the POWER BOOST provides a transient output current of 2 A for a few minutes.

For ambient temperatures above 60°C, the output current must be reduced by 2.5% per Kelvin increase in temperature. From 70°C onwards or in the case of thermal overload, the device reduces the output capacity for its own protection, and returns to normal operation when it has cooled down.

Parallel operation

Due to the current carrying capacity, a maximum of two devices may be connected in parallel on the DIN rail connector for redundancy. Without using the DIN rail connector, devices of the same type can be connected in parallel both for redundancy reasons as well as to improve performance.

To ensure symmetrical distribution of power, we recommend designing all cable connections from the power supply unit to a busbar of the same length and with the same conductor cross section. The system makes it advisable to install a protective circuit at the output of each device when more than two power supply units are connected in parallel (e.g. decoupling diode or DC fuse). This prevents high reverse feed currents in the event of a secondary device fault.

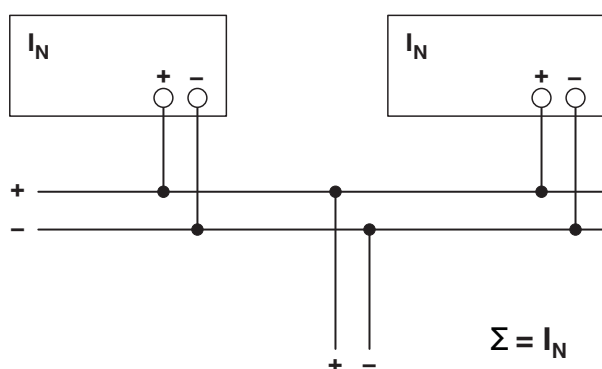

Redundant operation

Redundant circuits are suitable for the supply of systems which make especially high requirements on the operational safety. If a fault occurs in the primary circuit of the first power supply unit, the second device automatically takes over the entire power supply, without interruption, and vice versa. For this reason, the power supply units to be connected in parallel are dimensioned in such a way that the total current requirement of all consumers can be completely covered by one power supply unit. 100% redundancy makes external decoupling diodes necessary (QUINT-DIODE/40, Order No. 2938963)!

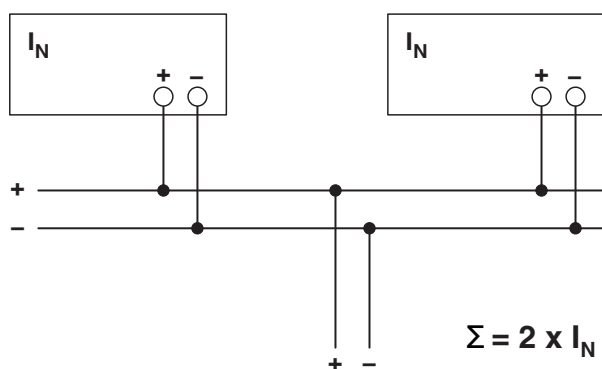

Increased performance

For n parallel connected devices, the output current can be increased to $n \times I_N$. Parallel connection to increase efficiency is used for the expansion of existing systems. It is advisable to use parallel connection if the power supply unit does not cover the current requirement of the most powerful consumer. Otherwise the consumers should be spread among individual devices independent of one another. A maximum of five devices can be connected in parallel!



SCATTERGOOD & JOHNSON LTD

ELECTRICAL ENGINEERING & FLUID CONTROL DISTRIBUTORS

Est.1899

At Scattergood & Johnson Ltd, we pride ourselves on being a technical distributor to specialist industries.

Working with a range of quality product suppliers across a number of specialist markets, we are not your average 'box shifter' - we are your technical and supply chain partner.

We fully support every product we sell - for free! Our internal team and external sales engineers can answer any product or application question, no matter the complexity.

Backing up this technical ability is a range of 50,000+ products available from stock for nationwide next day delivery (same day if required!), or you can collect what you need from any of our trade counters around the UK.

Select your specialist interest below to learn more about how we can help.



Online, In Branch and On the Road - Scattergood & Johnson Ltd, there when you need us.

www.scatts.co.uk