

Power supply unit - QUINT-PS/3AC/24DC/ 5 - 2866734

Please be informed that the data shown in this PDF Document is generated from our Online Catalog. Please find the complete data in the user's documentation. Our General Terms of Use for Downloads are valid (<http://phoenixcontact.com/download>)



Primary-switched QUINT POWER power supply for DIN rail mounting with SFB (Selective Fuse Breaking) Technology, input: 3-phase, output: 24 V DC/5 A

Product Description

QUINT POWER power supplies with maximum functionality

QUINT POWER circuit breakers magnetically and therefore quickly trip at six times the nominal current, for selective and therefore cost-effective system protection. The high level of system availability is additionally ensured, thanks to preventive function monitoring, as it reports critical operating states before errors occur.

Reliable starting of heavy loads takes place via the static power reserve POWER BOOST. Thanks to the adjustable voltage, all ranges between 5 V DC ... 56 V DC are covered.

Your advantages

- High level of system availability even in the event of permanent phase failure
- Reliable starting of difficult loads
- Preventive function monitoring



Key Commercial Data

Packing unit	1 pc
GTIN	 4 046356 155441
GTIN	4046356155441
Weight per Piece (excluding packing)	1,045.600 g
Custom tariff number	85044030
Country of origin	Thailand

Technical data

Dimensions

Width	40 mm
Height	130 mm
Depth	125 mm
Width with alternative assembly	122 mm
Height with alternative assembly	130 mm

Power supply unit - QUINT-PS/3AC/24DC/ 5 - 2866734

Technical data

Dimensions

Depth with alternative assembly	43 mm
---------------------------------	-------

Ambient conditions

Degree of protection	IP20
Ambient temperature (operation)	-25 °C ... 70 °C (> 60 °C Derating: 2.5 %/K)
Ambient temperature (start-up type tested)	-40 °C
Ambient temperature (storage/transport)	-40 °C ... 85 °C
Max. permissible relative humidity (operation)	≤ 95 % (at 25 °C, non-condensing)
Climatic class	3K3 (in acc. with EN 60721)
Degree of pollution	2
Installation height	5000 m

Input data

Nominal input voltage range	3x 400 V AC ... 500 V AC
Input voltage range	3x 320 V AC ... 575 V AC
	2x 360 V AC ... 575 V AC
	450 V DC ... 800 V DC
AC frequency range	45 Hz ... 65 Hz
Frequency range DC	0 Hz
Discharge current to PE	< 3.5 mA
Current consumption	3x 0.8 A (400 V AC)
	3x 0.7 A (500 V AC)
	0.2 A (600 V DC)
Nominal power consumption	268 VA
Inrush current	< 15 A (typical)
Mains buffering time	> 20 ms (400 V AC)
	> 30 ms (500 V AC)
Recommended breaker for input protection	6 A ... 16 A (AC: Characteristics B, C, D, K)
Power factor (cos phi)	0.5
Type of protection	Transient surge protection
Protective circuit/component	Varistor, gas-filled surge arrester

Output data

Nominal output voltage	24 V DC ±1 %
Setting range of the output voltage (U_{Set})	18 V DC ... 29.5 V DC (> 24 V DC, constant capacity restricted)
Nominal output current (I_N)	5 A (-25 °C ... 60 °C, $U_{OUT} = 24$ V DC)
POWER BOOST (I_{Boost})	7.5 A (-25 °C ... 40 °C permanent, $U_{OUT} = 24$ V DC)
Selective Fuse Breaking (I_{SFB})	30 A (12 ms)
Derating	60 °C ... 70 °C (2.5%/K)
Connection in parallel	Yes, for redundancy and increased capacity
Connection in series	yes
Feedback voltage resistance	max. 35 V DC

Power supply unit - QUINT-PS/3AC/24DC/ 5 - 2866734

Technical data

Output data

Protection against overvoltage at the output (OVP)	< 35 V DC
Residual ripple	< 20 mV _{PP} (with nominal values)
Output power	120 W
Typical response time	< 0.06 s
Peak switching voltages nominal load	< 20 mV _{PP} (at nominal values, 20 MHz)
Maximum power dissipation in no-load condition	4 W
Power loss nominal load max.	14 W

General

Net weight	0.7 kg
Operating voltage display	Green LED
Efficiency	> 89 % (at 400 V AC and nominal values)
Insulation voltage input/output	4 kV AC (type test) 2 kV AC (routine test)
Insulation voltage input / PE	3.5 kV AC (type test) 2 kV AC (routine test)
Insulation voltage output / PE	500 V DC (routine test)
Protection class	I
Degree of protection	IP20
MTBF (IEC 61709, SN 29500)	> 1290000 h (25 °C) > 680000 h (40 °C) > 290000 h (60 °C)
Mounting position	horizontal DIN rail NS 35, EN 60715
Assembly instructions	alignable: $P_N \geq 50\%$, 5 mm horizontally, 15 mm next to active components, 50 mm vertically alignable: $P_N < 50\%$, 0 mm horizontally, 40 mm vertically top, 20 mm vertically bottom

Connection data, input

Connection method	Pluggable screw connection
Conductor cross section solid min.	0.2 mm ²
Conductor cross section solid max.	2.5 mm ²
Conductor cross section flexible min.	0.2 mm ²
Conductor cross section flexible max.	2.5 mm ²
Conductor cross section AWG min.	20
Conductor cross section AWG max.	12
Stripping length	7 mm
Screw thread	M3

Connection data, output

Connection method	Pluggable screw connection
Conductor cross section solid min.	0.2 mm ²
Conductor cross section solid max.	2.5 mm ²

Power supply unit - QUINT-PS/3AC/24DC/ 5 - 2866734

Technical data

Connection data, output

Conductor cross section flexible min.	0.2 mm ²
Conductor cross section flexible max.	2.5 mm ²
Conductor cross section AWG min.	20
Conductor cross section AWG max.	12
Stripping length	7 mm
Screw thread	M3

Connection data for signaling

Connection method	Pluggable screw connection
Conductor cross section solid min.	0.2 mm ²
Conductor cross section solid max.	2.5 mm ²
Conductor cross section flexible min.	0.2 mm ²
Conductor cross section flexible max.	2.5 mm ²
Conductor cross section AWG min.	20
Conductor cross section AWG max.	12
Screw thread	M3

Standards and Regulations

Electromagnetic compatibility	Conformance with EMC Directive 2014/30/EU
Noise immunity	EN 61000-6-2:2005
Connection in acc. with standard	CSA
Standards/regulations	EN 61000-4-2
Contact discharge	4 kV (Test Level 2)
Standards/regulations	EN 61000-4-3
Frequency range	80 MHz ... 1 GHz
Test field strength	10 V/m (Test Level 3)
Frequency range	1.4 GHz ... 2 GHz
Test field strength	3 V/m (Test Level 2)
Standards/regulations	EN 61000-4-4
Comments	Criterion B
Standards/regulations	EN 61000-6-3
	EN 61000-4-6
Frequency range	0.15 MHz ... 80 MHz
Voltage	10 V (Test Level 3)
Low Voltage Directive	Conformance with LV directive 2006/95/EC
Standard - Electrical safety	IEC 60950-1/VDE 0805 (SELV)
Standard - Electronic equipment for use in electrical power installations and their assembly into electrical power installations	EN 50178/VDE 0160 (PELV)
Standard - Safety extra-low voltage	IEC 60950-1 (SELV) and EN 60204-1 (PELV)
Standard - Safe isolation	DIN VDE 0100-410
Standard - Protection against shock currents, basic requirements for protective separation in electrical equipment	EN 50178

Power supply unit - QUINT-PS/3AC/24DC/ 5 - 2866734

Technical data

Standards and Regulations

Standard – Limitation of mains harmonic currents	EN 61000-3-2
Standard - Equipment safety	GS (tested safety)
Standard - Approval for medical use	IEC 60601-1, 2 x MOOP
Shipbuilding approval	DNV GL (EMC A), ABS, LR, RINA, NK, BV
UL approvals	UL Listed UL 508
	UL/C-UL Recognized UL 60950-1 (3-wire + PE, star net)
	UL ANSI/ISA-12.12.01 Class I, Division 2, Groups A, B, C, D (Hazardous Location)
Shock	18 ms, 30g, in each space direction (according to IEC 60068-2-27)
Vibration (operation)	< 15 Hz, amplitude ±2.5 mm (according to IEC 60068-2-6)
	15 Hz ... 150 Hz, 2.3g, 90 min.
Approval - requirement of the semiconductor industry with regard to mains voltage dips	SEMI F47-0706 Compliance Certificate
Certificate	CB Scheme
Rail applications	EN 50121-4
Overvoltage category (EN 62477-1)	III

Environmental Product Compliance

REACH SVHC	Lead 7439-92-1
China RoHS	Environmentally Friendly Use Period = 25;
	For details about hazardous substances go to tab "Downloads", Category "Manufacturer's declaration"

Drawings

Block diagram

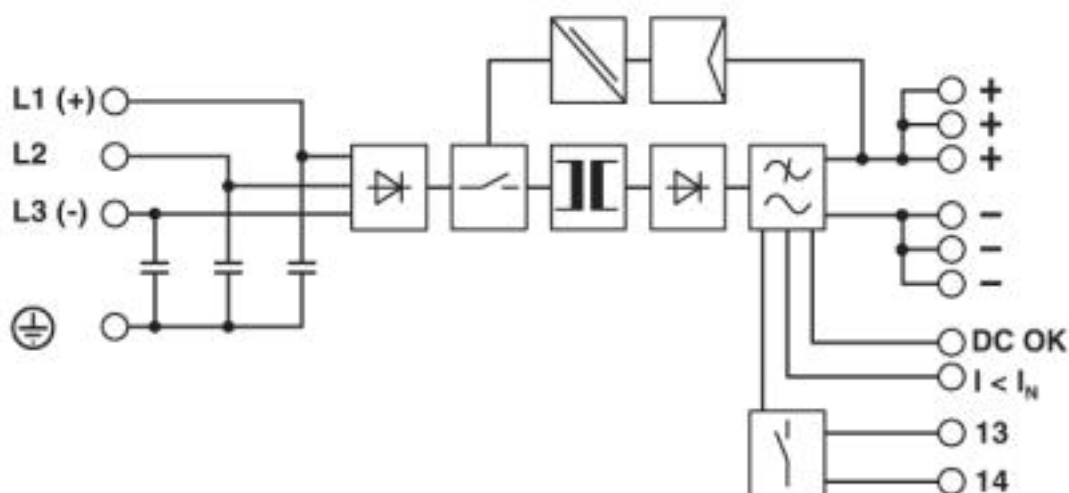

<https://www.phoenixcontact.com/gb/products/2866734>



Power supply unit - QUINT-PS/3AC/24DC/ 5 - 2866734

Classifications

eCl@ss

eCl@ss 4.0	27040700
eCl@ss 4.1	27040700
eCl@ss 5.0	27049000
eCl@ss 5.1	27049000
eCl@ss 6.0	27049000
eCl@ss 7.0	27049002
eCl@ss 8.0	27049002
eCl@ss 9.0	27040701

ETIM

ETIM 2.0	EC001039
ETIM 3.0	EC001039
ETIM 4.0	EC000599
ETIM 5.0	EC002540
ETIM 6.0	EC002540
ETIM 7.0	EC002540

UNSPSC

UNSPSC 6.01	30211502
UNSPSC 7.0901	39121004
UNSPSC 11	39121004
UNSPSC 12.01	39121004
UNSPSC 13.2	39121004

Approvals

Approvals

Approvals

DNV GL / CSA / BV / LR / NK / ABS / RINA / UL Listed / UL Recognized / cUL Recognized / IECCE CB Scheme / SEMI F47 / EAC / EAC / cULus Recognized

Ex Approvals







UL Listed / cUL Listed / cULus Listed

Approval details

DNV GL		https://approvalfinder.dnvgl.com/	TAE000014W
--------	---	---	------------

Power supply unit - QUINT-PS/3AC/24DC/ 5 - 2866734

Approvals

CSA		http://www.csagroup.org/services-industries/product-listing/	1921250
BV		http://www.veristar.com/portal/veristarinfo/generalinfo/approved/approvedProducts/equipmentAndMaterials	21004-C0 BV
LR		http://www.lr.org/en	08/20069 E4
NK		http://www.classnk.or.jp/hp/en/	08A039
ABS		http://www.eagle.org/eagleExternalPortalWEB/	15- HG1375463-1-PDA
RINA		http://www.rina.org/en	ELE316517XG
UL Listed		http://database.ul.com/cgi-bin/XYV/template/LISEXT/1FRAME/index.htm	FILE E 123528
UL Recognized		http://database.ul.com/cgi-bin/XYV/template/LISEXT/1FRAME/index.htm	FILE E 211944
cUL Recognized		http://database.ul.com/cgi-bin/XYV/template/LISEXT/1FRAME/index.htm	FILE E 211944
IECEE CB Scheme		http://www.iecee.org/	SI-2301
SEMI F47			SEMI F47

Power supply unit - QUINT-PS/3AC/24DC/ 5 - 2866734

Approvals

EAC		EAC-Zulassung
-----	---	---------------

EAC		RU C- DE.A*30.B.01082
-----	---	--------------------------

cULus Recognized		
------------------	---	--



SCATTERGOOD & JOHNSON LTD

ELECTRICAL ENGINEERING & FLUID CONTROL DISTRIBUTORS

Est.1899

At Scattergood & Johnson Ltd, we pride ourselves on being a technical distributor to specialist industries.

Working with a range of quality product suppliers across a number of specialist markets, we are not your average 'box shifter' - we are your technical and supply chain partner.

We fully support every product we sell - for free! Our internal team and external sales engineers can answer any product or application question, no matter the complexity.

Backing up this technical ability is a range of 50,000+ products available from stock for nationwide next day delivery (same day if required!), or you can collect what you need from any of our trade counters around the UK.

Select your specialist interest below to learn more about how we can help.



Online, In Branch and On the Road - Scattergood & Johnson Ltd, there when you need us.

www.scatts.co.uk