

STEP-PS/1AC/24DC/4.2

Primary-switched power supply for building automation

INTERFACE

Data sheet
103508_en_01

© PHOENIX CONTACT - 07/2009



1 Description

STEP POWER power supply units – for building automation

The new STEP POWER generation of compact power supply units is particularly suitable for installation distributors and flat control panels thanks to its design. The power supply units are available with 24 V DC output voltage in four performance classes and widths and with the special voltages 5, 12, 15 and 48 V DC. Their high degree of efficiency and the low standby losses make for high power efficiency.

Features

- Easy assembly on the DIN rail or panel
- Maximum energy efficiency thanks to low idling losses
- Quick startup with LED function monitoring
- High operating safety due to long mains buffering under full load and high MTBF (> 500,000 h)
- Can be used worldwide in all industrial sectors due to a wide-range input and an international approval package
- Wide temperature range of -25°C to +70°C
- Parallel connection possible for increased performance and redundancy



DANGER OF EXPLOSION!

Only remove equipment when it is disconnected and not in the potentially explosive area.



DANGER

The device contains dangerous live elements and high levels of stored energy. Never carry out work when the power is turned on.



Make sure you always use the latest documentation. It can be downloaded at www.phoenixcontact.net/download

2 Table of contents

1	Description	1
	Features.....	1
2	Table of contents.....	2
3	Ordering data	3
4	Technical data	3
5	Structure.....	6
6	Block diagram	7
7	Safety notes	7
8	Installation	8
9	Installation position.....	8
10	Mounting on DIN rails	9
	Assembly	9
	Removing.....	9
11	Connection to various systems.....	9
12	Input	10
	Protection of the primary side.....	10
	Recommended backup fuse for mains protection	10
13	Output	10
	Protection of the secondary side.....	10
14	Signaling	11
15	Function	11
	Output characteristic curve	11
	Thermal behavior	12
	Parallel operation	12
	Redundant operation	12
	Increased performance.....	13

3 Ordering data

Description	Type	Order No.	Pcs. / Pkt.
DIN rail power supply unit 24 V DC/4.2 A, primary switched-mode, 1-phase.	STEP-PS/1AC/24DC/4.2	2868664	1

4 Technical data

Input data	
Input nominal voltage range	100 V AC ... 240 V AC
AC input voltage range	85 V AC ... 264 V AC
DC input voltage range	95 V DC ... 250 V DC
AC frequency range	45 Hz ... 65 Hz
DC frequency range	0 Hz
Current consumption	Approx. 1.3 A (120 V AC) Approx. 0.8 A (230 V AC)
Inrush current limitation	< 15 A (typical)
I^2t	< 1 A ² s
Power failure bypass	> 20 ms (120 V AC) > 100 ms (230 V AC)
Typical response time	< 0.5 s
Protective circuitry	Transient surge protection Varistor
Input fuse, integrated	4 A (slow-blow, internal)
Recommended backup fuse for mains protection	6 A 10 A 16 A (characteristic B)
Output data	
Nominal output voltage	24 V DC \pm 1%
Setting range of the output voltage	22.5 V DC ... 29.5 V DC (> 24 V constant capacity)
Output current	4.2 A (-25°C ... 70°C) 4.4 A (-25°C ... 40°C permanent) 6.5 A (maximum output current)
Derating	Above +55°C: 2.5% per Kelvin
Control deviation	< 1 % (change in load, static 10% ... 90%) < 2 % (change in load, dynamic 10% ... 90%) < 0.1 % (change in input voltage \pm 10%)
Power loss nominal load max.	13.2 W
Maximum power dissipation idling	0.7 W
Efficiency	> 88 % (for 230 V AC and nominal values)
Ascent time	< 0.5 s (U_{OUT} (10% ... 90%))
Residual ripple	< 25 mV _{PP} (with nominal values)
Peak switching voltages	< 25 mV _{PP} (with nominal values)
Connection in parallel	Yes, for redundancy and increased capacity
Connection in series	Yes
Surge protection against internal surge voltages	Yes, limited to approx. 35 V DC
Resistance to reverse feed	max. 35 V DC
LED status indicator	
Status display	"DC OK" LED green / U_{OUT} > 21.5 V: LED lights up

General data

Insulation voltage input/output	4 kV AC (type test) 2 kV AC (routine test)
Degree of protection	IP20
Class of protection	II
MTBF	> 500 000 h in acc. with IEC 61709 (SN 29500)
Dimensions W / H / D (state of delivery)	90 mm / 90 mm / 61 mm
Weight	0.4 kg

Ambient conditions

Ambient temperature (operation)	-25 °C ... 70 °C (> 55° C derating)
Ambient temperature (storage/transport)	-40 °C ... 85 °C
Max. permissible relative humidity (operation)	95 % (at 25 °C, no condensation)
Vibration (operation)	< 15 Hz, amplitude ±2.5 mm in acc. with IEC 60068-2-6 15 Hz ... 150 Hz, 2.3g, 90 min.
Shock	30g in all directions in acc. with IEC 60068-2-27
Pollution degree in acc. with EN 50178	2
Climatic class	3K3 (in acc. with EN 60721)

Standards

Electrical Equipment for Machinery	EN 60204
Safety transformers for power supply units	IEC 61558-2-17
Electrical safety (of information technology equipment)	IEC 60950/VDE 0805 (SELV)
Electronic equipment for use in electrical power installations	EN 50178/VDE 0160 (PELV)
SELV	IEC 60950 (SELV) and EN 60204 (PELV)
Safe isolation	DIN VDE 0100-410 DIN VDE 0106-1010
Protection against electric shock	DIN 57100-410
Protection against electric shock, basic requirements for safe isolation in electrical equipment	DIN VDE 0106-101
Limitation of mains harmonic currents	EN 61000-3-2
Certificate	CB Scheme

Approvals

UL approvals	UL/C-UL listed UL 508 UL/C-UL Recognized UL 60950
Shipbuilding	Germanischer Lloyd

Conformance with EMC guideline 2004/108/EC and for low-voltage guideline 2006/95/EC**Noise immunity according to EN 61000-6-2**

Electrostatic discharge	EN 61000-4-2	
	Housing	Level 3
	Contact discharge	± 6 kV (Contact discharge)
	Discharge in air	± 8 kV (Air discharge)
	Comments	Criterion B
Electromagnetic HF field	EN 61000-4-3	
	Housing	Level 4
	Frequency range	80 MHz ... 3000 MHz
	Field intensity	10 V/m
	Comments	Criterion A
Fast transients (burst)	EN 61000-4-4	
	Input	4 kV (level 4 - asymmetrical)
	Output	2 kV (Level 3 - asymmetrical)
	Comments	Criterion B
Surge current loads (surge)	EN 61000-4-5	
	Input	4 kV (asymmetrical: Conductor to ground) 2 kV (symmetrical: Conductor to conductor)
	Output	2 kV (level 3 - asymmetrical: conductor to ground) 1 kV (Level 3 - symmetrical: Conductor to conductor)
	Comments	Criterion B
Conducted interference	EN 61000-4-6	
	Input/output	Level 3 - asymmetrical
	Frequency range	10 kHz ... 80 MHz
	Voltage	10 V
	Comments	Criterion A
Voltage dips	EN 61000-4-11	
	Input	(mains buffering > 20 ms)
	Comments	Criterion A

Emitted interference in acc. with EN 61000-6-3

Radio interference voltage in acc. with EN 55011	EN 55011 (EN 55022) class B used in industry and residential area / EMC 1
Emitted radio interference in acc. with EN 55011	EN 55011 (EN 55022) class B used in industry and residential area / EMC 1

5 Structure

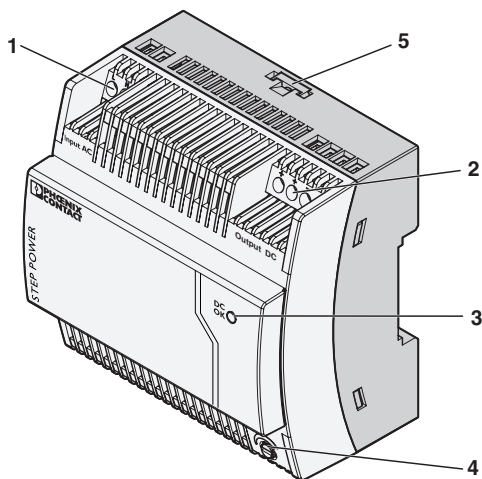

- 1 AC input
- 2 DC output
- 3 "DC OK" LED
- 4 Potentiometer 22.5 V DC ... 29.5 V DC
- 5 Universal snap-on foot for EN DIN rails and for wall mounting

	[mm ²]		AWG	[Nm] Torque
	solid	stranded		
Input	0.2 - 2.5	0.2 - 2.5	24 - 12	0.6 - 0.8
Output	0.2 - 2.5	0.2 - 2.5	24 - 12	0.6 - 0.8

Input data

Input nominal voltage range	100 V AC ... 240 V AC
AC input voltage range	85 V AC ... 264 V AC
DC input voltage range	95 V DC ... 250 V DC
AC frequency range	45 Hz ... 65 Hz
DC frequency range	0 Hz
Input fuse, integrated	4 A (slow-blow, internal)
Recommended backup fuse for mains protection	6 A 10 A 16 A (characteristic B)

Type of connection	Screw connection
Stripping length	6.5 mm

Output data

Nominal output voltage	24 V DC \pm 1%
Setting range of the output voltage	22.5 V DC ... 29.5 V DC (> 24 V constant capacity)
Output current	4.2 A (-25°C ... 70°C) 4.4 A (-25 °C ... 40 °C permanent) 6.5 A (maximum output current)

Type of connection	Screw connection
Stripping length	6.5 mm

6 Block diagram

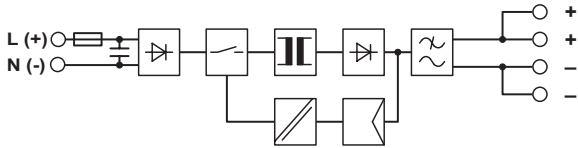

7 Safety notes



DANGER OF EXPLOSION!

Only remove equipment when it is disconnected and not in the potentially explosive area.

DANGER

The device contains dangerous live elements and high levels of stored energy.
Never carry out work when the power is turned on.



WARNING

Before startup please ensure:

The mains connection has been carried out by a competent person and protection against electric shock is guaranteed!

The device can be disconnected outside the power supply unit in accordance with the regulations as in EN 60950 (e.g. through primary side line protection)!

All feed lines are sufficiently protected and dimensioned!

All output lines are dimensioned according to the maximum output current of the device or separately protected!

Sufficient convection is guaranteed!



CAUTION

The power supply units are built-in devices. The device may only be installed and put into operation by qualified personnel. The corresponding national regulations must be observed.

8 Installation

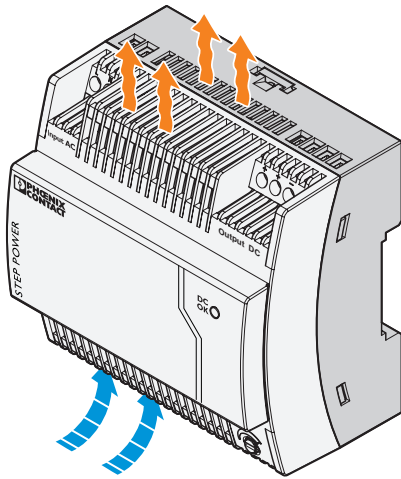

ATTENTION

In order to ensure sufficient convection, we recommend a minimum vertical distance of 30 mm to the other devices.



The power supply can be snapped onto all DIN rails in accordance with EN 60715. Wall mounting is also possible. The device must be mounted horizontally (connection terminal blocks on top).

9 Installation position

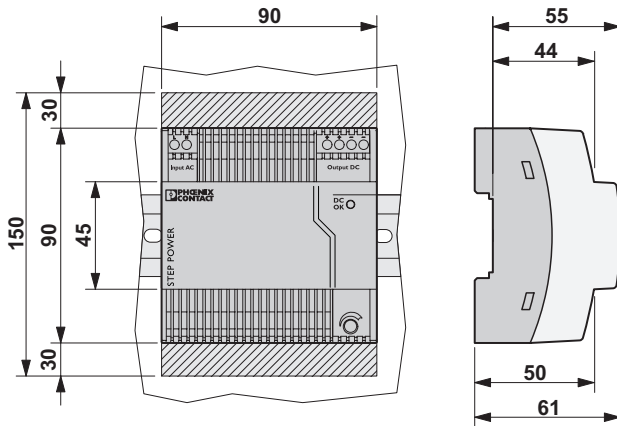

10 Mounting on DIN rails

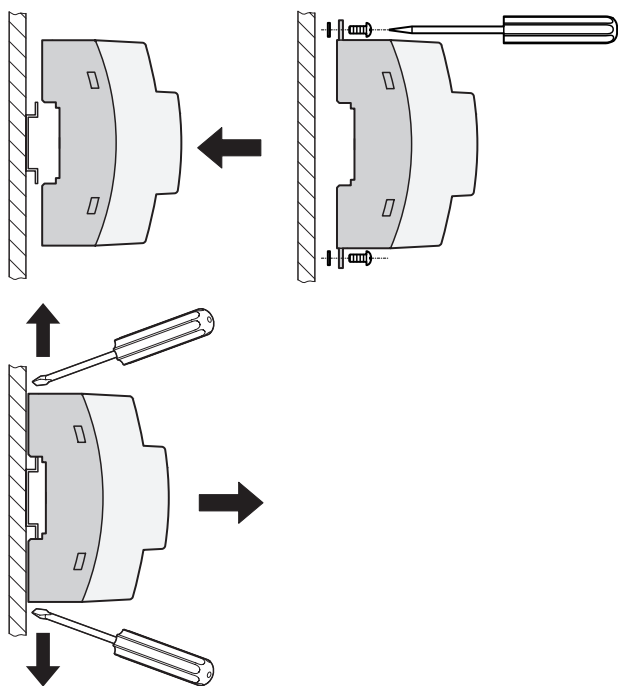

Assembly

To mount on an EN DIN rail, snap the device straight onto the DIN rail.

If the power supply unit is to be fastened directly onto an even surface, press the orange base latch upward and down.

Place a washer between the pulled-out base latch and the even surface (max. outer diameter 8.5 mm, max. thickness 1.3 mm, e.g., spring washer for M4 in acc. with DIN 127-B or toothed lock washer in acc. with DIN 6797).

Then fasten the device with two screws (max. thread diameter 4 mm, max. head diameter 8.5 mm).

Removing

To dismantle from the EN DIN rail, press the orange base latch outward and pull the device off of the DIN rail.

In the case of wall mounting, loosen the screws and press the base latch inwards again.

11 Connection to various systems

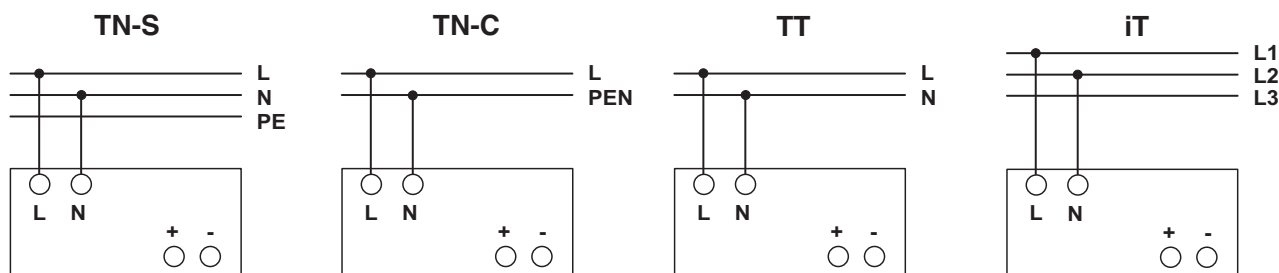

The 100 V AC ... 240 V AC connection is made using the L and N screw connections.

The device can be connected to 1-phase AC networks or to two of the phase conductors of three-phase systems (TN, TT or IT networks in acc. with VDE 0100-300/IEC 60364-3) with nominal voltages of 100 V AC ...240 V AC.



For operation on two of the phase conductors of a three-phase system, an isolating facility for all poles must be provided.

12 Input

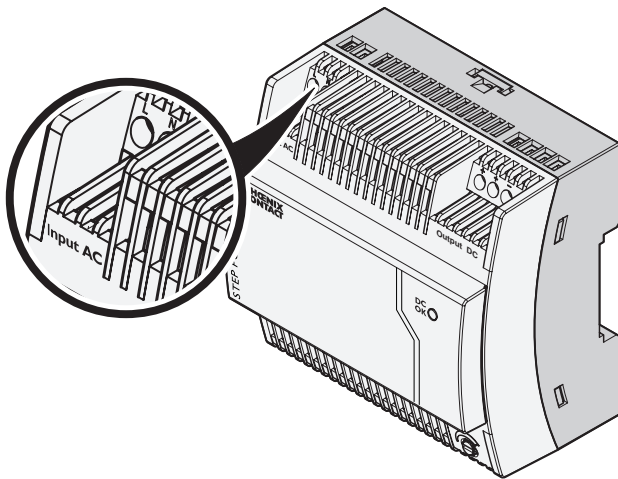

CAUTION

If an internal fuse is triggered, there is most probably a malfunction in the device. In this case, the device must be inspected in the factory!

Protection of the primary side

The device must be installed in acc. with the regulations as in EN 60950. It must be possible to disconnect the device using a suitable isolating facility outside the power supply.

The primary side line protection, for example, is suitable. For device protection, there is an internal fuse. Additional device protection is not necessary.

Recommended backup fuse for mains protection

Power circuit-breaker 6 A, 10 A or 16 A, characteristic B (or identical function). Connect a suitable fuse upstream for DC applications!

13 Output

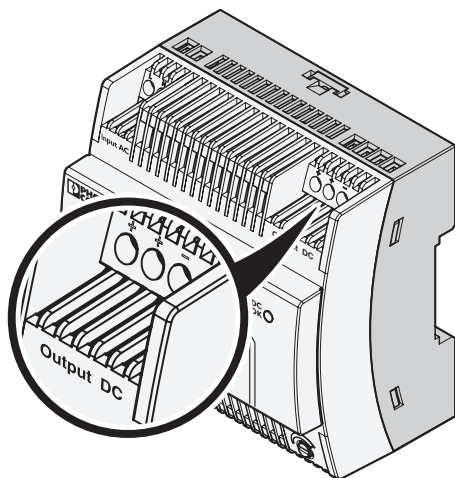

CAUTION

Make sure that all output lines are dimensioned according to the maximum output current or are separately protected. The cables on the secondary side must have sufficiently large cross sections in order to keep the voltage drops on the lines as low as possible.

The connection is made using the "+" and "-" screw connections on the screw connection of the DC output. At the time of delivery, the output voltage is 24 V DC. The output voltage can be set on the potentiometer.

Protection of the secondary side

The device is electronically protected against short circuit and idling. In the event of a malfunction, the output voltage is limited to 35 V DC.

14 Signaling

The "DC OK" LED enables evaluation of the function of the power supply directly on site.

	State 1	State 2
"DC OK" LED	ON	OFF
Cause	Output voltage > 21.5 V	Output voltage < 21,5 V or no voltage at the output
Meaning	Output voltage and output current OK	The device is in operation, but there is a fault in the consumer, the current consumption is greater than I_1 or the output is short circuited. The device is out of operation because there is no mains voltage, the fuse on the primary side has been triggered, or the device is faulty.

15 Function

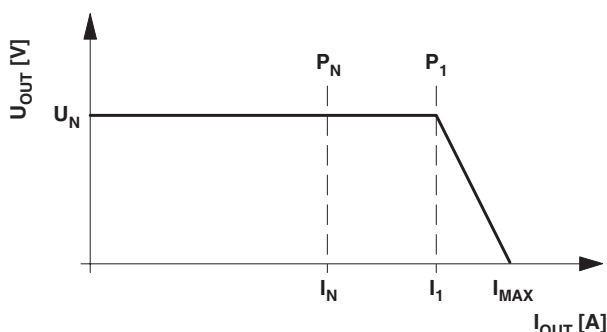

Output characteristic curve

The power supply works with a power reserve as shown in the U/I characteristic curve in the figure. At ambient temperatures $T_{AMB} < +40^\circ\text{C}$, I_1 is available continuously. At higher temperatures, it's available for a few minutes. In the event of a secondary-side short circuit or overload, the output current is limited to I_{MAX} . Thereby, the module does not switch off, but rather supplies a continuous output current. The secondary voltage is reduced here until the short circuit is eliminated. The U/I characteristic curve with the power reserve ensures that both high inrush currents of capacitive loads as well as consumers with DC/DC converters in the primary circuit can be supplied.

$$U_N = 24 \text{ V}$$

$$I_N = 4.2 \text{ A}$$

$$P_N = 100 \text{ W}$$

$$I_1 = 4.4 \text{ A}$$

$$P_1 = 105.6 \text{ W}$$

$$I_{MAX} = 6.5 \text{ A } (U_{OUT} = 0 \text{ V})$$

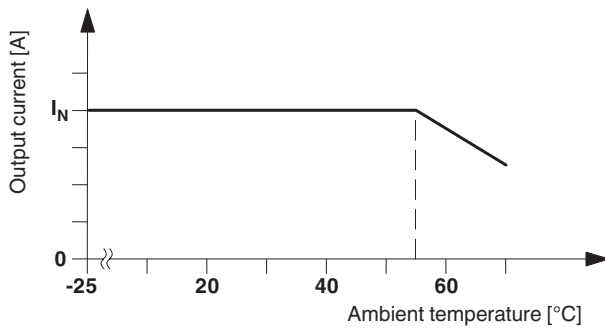

Thermal behavior

With an ambient temperature of up to +55°C, the device supplies the continuous output current of I_N . In the case of ambient temperatures above +55°C, the output current must be reduced by 2.5% per Kelvin increase in temperature. The device does not switch off at ambient temperatures of +70°C or thermal overload. The output capacity is reduced as far as necessary to provide device protection. After it has cooled down, the output capacity is increased again.

Parallel operation

Devices of the same type can be connected in parallel to enable both redundancy and an increase in efficiency. On default upon delivery, a further adjustment is not needed. If the output voltage is adjusted, a uniform distribution of power is guaranteed by setting all parallel operated power supply units to exactly the same output voltage. To ensure symmetrical current distribution we recommend that all cable connections from the power supply unit to the busbar are the same length and have the same cross-section! Depending on the system, for parallel connection of more than two power supply units a protective circuit should be installed at each individual device output (e.g. decoupling diode, DC fuse or power circuit breaker). This prevents high return currents in the event of a secondary device fault.

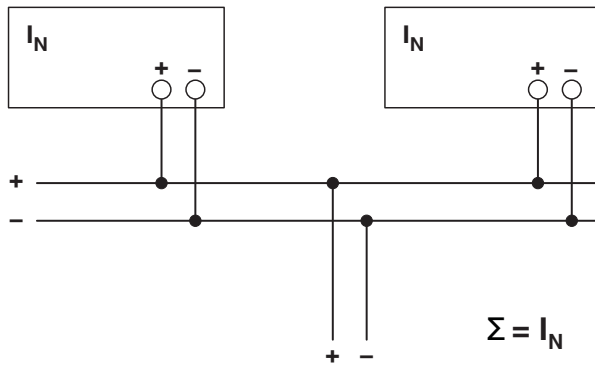

Redundant operation

Redundant circuits are suitable for the supply of systems which make especially high requirements on the operational safety. If a fault occurs in the primary circuit of the first power supply unit, the second device automatically takes over the entire power supply, without interruption, and vice versa. For this reason, the power supply units to be connected in parallel are dimensioned in such a way that the total current requirement of all consumers can be completely covered by one power supply unit. 100% redundancy makes external decoupling diodes necessary (QUINT-DIODE/40, Order No. 2938963)!

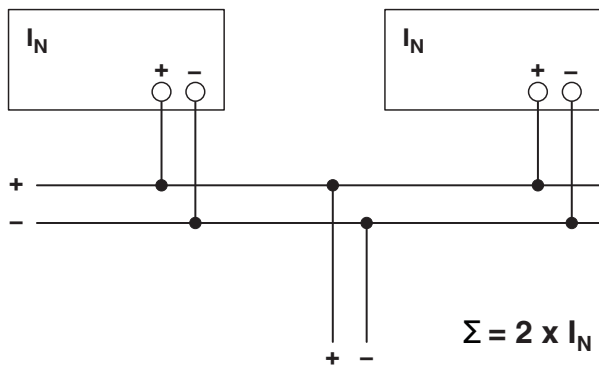
**Increased performance**

For n parallel connected devices, the output current can be increased to $n \times I_N$. Parallel connection to increase efficiency is used for the expansion of existing systems. It is advisable to use parallel connection if the power supply unit does not cover the current requirement of the most powerful consumer. Otherwise the consumers should be spread among individual devices independent of one another. A maximum of five devices can be connected in parallel!



SCATTERGOOD & JOHNSON LTD

ELECTRICAL ENGINEERING & FLUID CONTROL DISTRIBUTORS

Est.1899

At Scattergood & Johnson Ltd, we pride ourselves on being a technical distributor to specialist industries.

Working with a range of quality product suppliers across a number of specialist markets, we are not your average 'box shifter' - we are your technical and supply chain partner.

We fully support every product we sell - for free! Our internal team and external sales engineers can answer any product or application question, no matter the complexity.

Backing up this technical ability is a range of 50,000+ products available from stock for nationwide next day delivery (same day if required!), or you can collect what you need from any of our trade counters around the UK.

Select your specialist interest below to learn more about how we can help.



Online, In Branch and On the Road - Scattergood & Johnson Ltd, there when you need us.

www.scatts.co.uk