

UNO-PS/1AC/24DC/ 30W

Primary-switched power supply unit

Data sheet
105516_en_02

© PHOENIX CONTACT 2018-07-03



1 Description

The UNO POWER power supply unit impresses in worldwide use thanks to maximum energy efficiency. Low idling losses and the high degree of efficiency save energy.

Thanks to its high power density, the UNO POWER power supply unit is the ideal solution, particularly in compact control boxes.

Features

- Worldwide use thanks to input voltage range of 85 V AC ... 264 V AC
- Superior system availability through reliable power supply with 24 V DC
- Maximum energy efficiency thanks to optimized efficiency over the entire operating range of the power supply unit and low idling losses
- Particularly compact: 30 W of power from this narrow power supply unit, which is just 22.5 mm wide
- Short-circuit-proof and idling-proof

Technical data (short form)

Input voltage range	85 V AC ... 264 V AC
Mains buffering	> 25 ms (120 V AC) > 115 ms (230 V AC)
Nominal output voltage (U_N)	24 V DC \pm 1 %
Nominal output current (I_N)	1.25 A (-25 °C ... 55 °C)
Output power (P_N)	30 W
Efficiency (for nominal values)	typ. 87 % (120 V AC) typ. 88 % (230 V AC)
Residual ripple	< 60 mV _{PP}
MTBF (IEC 61709, SN 29500)	> 1158000 h (40 °C)
Ambient temperature (operation)	-25 °C ... 70 °C > 55 °C Derating: 2.5 %/K
Dimensions W/H/D	22.5 mm / 90 mm / 84 mm
Weight	0.15 kg



Make sure you always use the latest documentation.
It can be downloaded from the product at [phoenixcontact.net/products](https://www.phoenixcontact.net/products).

2	Table of contents	
1	Description	1
2	Table of contents	2
3	Ordering data	3
4	Technical data	4
5	Intended use	9
6	Structure	9
	6.1 Device elements	9
	6.2 Block diagram	9
7	Mounting	10
	7.1 Unpacking	10
	7.2 Mounting the power supply unit	10
	7.3 Mounting on a DIN rail	12
	7.4 Normal mounting position	12
8	Installing the power supply unit	13
	8.1 Safety regulations and installation notes	13
	8.2 High-voltage test (HIPOT)	14
	8.3 Mains connection	15
	8.4 Device connections	15
	8.5 Connecting cables	16
9	Operating behavior of the power supply unit	16
	9.1 Normal operation	16
	9.2 Overload response	16
	9.3 Behavior at ambient temperatures > 55°C	16
	9.4 Behavior in the case of alternative mounting positions	17
10	Operating the power supply unit	20
	10.1 Function monitoring	20
	10.2 Operating power supply units in parallel	21
	10.3 Operating the power supply unit in series	22
11	Removal	22
	11.1 Removing the power supply unit	22
	11.2 Notes on disposal	22

3 Ordering data

Description	Type	Order No.	Pcs./Pkt.
Primary-switched UNO POWER power supply for DIN rail mounting, input: 1-phase, output: 24 V DC/30 W	UNO-PS/1AC/24DC/ 30W	2902991	1
Accessories	Type	Order No.	Pcs./Pkt.
Redundancy module, 5 V - 24 V DC, 2 x 10 A, 1 x 20 A.	UNO-DIODE/5-24DC/2X10/1X20	2905489	1
Multi-channel electronic device circuit breaker for protecting four loads at 24 V DC in the event of overload and short circuit. With electronic locking of the set nominal currents. For installation on DIN rails.	CBMC E4 24DC/1-4A NO	2906031	1
Multi-channel electronic device circuit breaker for protecting four loads at 24 V DC in the event of overload and short circuit. With electronic locking of the set nominal currents. For installation on DIN rails.	CBMC E4 24DC/1-10A NO	2906032	1
Type 2/3 surge protection, consisting of protective plug and base element, with integrated status indicator and remote signaling for single-phase power supply networks. Nominal voltage 230 V AC/DC.	PLT-SEC-T3-230-FM-UT	2907919	5
Type 3 surge protection, consisting of protective plug and base element, with integrated status indicator and remote signaling for single-phase power supply networks. Nominal voltage 24 V AC/DC.	PLT-SEC-T3-24-FM-UT	2907916	5



Our range of accessories is being continually extended, our current range can be found in the download area.

4 Technical data

Input data	
Nominal input voltage	100 V AC ... 240 V AC
Input voltage range	85 V AC ... 264 V AC
Frequency range (f_N)	50 Hz ... 60 Hz \pm 5 Hz
Current consumption (for nominal values) typ.	0.8 A (100 V AC) 0.4 A (240 V AC)
Inrush current limitation (at 25°C) typ.	< 20 A
I^2t typ.	< 0.4 A ² s
Typical response time	< 1 s
Mains buffering	> 25 ms (120 V AC) > 115 ms (230 V AC)
Protective circuit	Transient surge protection Varistor
Input fuse, integrated	2 A (slow-blow, internal)
Choice of suitable circuit breakers Characteristics B, C, D, K	6 A ... 16 A
Input connection data	
Connection method	Screw connection
Conductor cross section, solid	0.2 mm ² ... 2.5 mm ²
Conductor cross section, flexible	0.2 mm ² ... 2.5 mm ²
Conductor cross section AWG/kcmil	24 ... 14
Stripping length	8 mm
Screw thread	M3
Tightening torque	0.5 Nm ... 0.6 Nm
Output data	
Nominal output voltage (U_N)	24 V DC \pm 1 %
Nominal output current (I_N)	1.25 A (-25 °C ... 55 °C)
Derating	55 °C ... 70 °C (2.5%/K)
Control deviation	< 1 % (change in load, static 10 % ... 90 %) < 2 % (Dynamic load change 10 % ... 90 %, 10 Hz) < 0.1 % (change in input voltage \pm 10 %)
Rise time	< 0.5 s (U_{OUT} (10 % ... 90 %))
Residual ripple	< 60 mV _{PP} (with nominal values)
Connection in parallel	yes, with redundancy module
Connection in series	yes
Protection against surge voltage on the output	\leq 35 V DC
Feedback resistance	< 35 V DC

Output connection data	
Connection method	Screw connection
Conductor cross section, solid	0.2 mm ² ... 2.5 mm ²
Conductor cross section, flexible	0.2 mm ² ... 2.5 mm ²
Conductor cross section AWG/kcmil	24 ... 14
Stripping length	8 mm
Screw thread	M3
Tightening torque	0.5 Nm ... 0.6 Nm
Power consumption	
Efficiency (for nominal values) typ.	87 % (120 V AC) / 88 % (230 V AC)
Maximum power dissipation in no-load condition	< 0.3 W
Power loss nominal load max.	< 5 W
General data	
Insulation voltage input/output	4 kV AC (type test) 3 kV AC (routine test)
MTBF (IEC 61709, SN 29500)	> 1158000 h (40 °C)
Housing material	Polycarbonate
Foot latch material	POM (Polyoxymethylen)
Inflammability class in acc. with UL 94 (housing / terminal blocks)	V0
Degree of protection	IP20
Protection class	II (in closed control cabinet)
Dimensions W/H/D	22.5 mm / 90 mm / 84 mm
Weight	0.15 kg
Ambient conditions	
Ambient temperature (operation)	-25 °C ... 70 °C (> 55 °C Derating: 2.5 %/K)
Ambient temperature (start-up type tested)	-40 °C
Ambient temperature (storage/transport)	-40 °C ... 85 °C
Max. permissible relative humidity (operation)	≤ 95 % (at 25 °C, non-condensing)
Vibration (operation)	< 15 Hz, amplitude ±2.5 mm (according to IEC 60068-2-6) 15 Hz ... 150 Hz, 2.3g, 90 min.
Shock	18 ms, 30g, in each space direction (according to IEC 60068-2-27)
Degree of pollution	2
Climatic class	3K3 (in acc. with EN 60721)

Standards

Safety of power supply units up to 1100 V (insulation distances)	EN 61558-2-16
Electrical safety (of information technology equipment - Safety - Part 1)	IEC 60950-1/VDE 0805 (SELV)
Electronic equipment for use in electrical power installations	EN 50178/VDE 0160 (PELV)
SELV	IEC 60950-1 (SELV) and EN 60204-1 (PELV)
Safe isolation	DIN VDE 0100-410
Limitation of mains harmonic currents	EN 61000-3-2
Network version/undervoltage	EN 61000-4-11
Information technology equipment - Safety (CB Scheme)	CB Scheme

Approvals

UL approvals	UL/C-UL listed UL 508 UL/C-UL Recognized UL 60950-1 NEC Class 2 as per UL 1310 UL/C-UL Listed ANSI/ISA-12.12.01 Class I, Division 2, Groups A, B, C, D T4 (Hazardous Location)
CSA	CAN/CSA-C22.2 No. 60950-1-07 CSA-C22.2 No. 107.1-01 CAN/CSA-C22.2 No. 213 Class I, Division 2, Groups A, B, C, D T4 (Hazardous Location)



Current approvals/permissions for the product can be found in the download area under phoenixcontact.net/products

Conformance with EMC Directive 2014/30/EU		
Noise immunity according to EN 61000-6-2		
	EN 61000-6-2 requirement	tested
Electrostatic discharge EN 61000-4-2		
Housing contact discharge	4 kV (Test Level 2)	6 kV (Test Level 3)
Housing air discharge	8 kV (Test Level 3)	8 kV (Test Level 3)
Comments	Criterion B	Criterion B
Electromagnetic HF field EN 61000-4-3		
Frequency range	80 MHz ... 1 GHz	80 MHz ... 1 GHz
Test field strength	10 V/m	10 V/m
Frequency range	1.4 GHz ... 2 GHz	1 GHz ... 2 GHz
Test field strength	3 V/m	10 V/m
Frequency range	2 GHz ... 2.7 GHz	2 GHz ... 3 GHz
Test field strength	1 V/m	10 V/m
Comments	Criterion A	Criterion A
Fast transients (burst) EN 61000-4-4		
Input	2 kV (Test Level 3 - asymmetrical)	4 kV (Test Level 4 - asymmetrical)
Output	2 kV (Test Level 3 - asymmetrical)	2 kV (Test Level 3 - asymmetrical)
Comments	Criterion B	Criterion B
Surge current loads (surge) EN 61000-4-5		
Input	1 kV (Test Level 2 - symmetrical) 2 kV (Test Level 3 - asymmetrical)	2 kV (Test Level 3 - symmetrical) 4 kV (Test Level 4 - asymmetrical)
Output	0.5 kV (Test Level 1 - symmetrical) 0.5 kV (Test Level 1 - asymmetrical)	1 kV (Test Level 2 - symmetrical) 2 kV (Test Level 3 - asymmetrical)
Comments	Criterion B	Criterion B
Conducted interference EN 61000-4-6		
Frequency range	10 kHz ... 80 MHz	10 kHz ... 80 MHz
Voltage	10 V (Test Level 3)	10 V (Test Level 3)
Comments	Criterion A	Criterion A
Key		
Criterion A	Normal operating behavior within the specified limits.	
Criterion B	Temporary impairment to operational behavior that is corrected by the device itself.	

Emitted interference in acc. with EN 61000-6-3

Radio interference voltage in acc. with EN 55011

EN 55011 (EN 55022) class B used in industry and residential area / EMC 1

Emitted radio interference in acc. with EN 55011

EN 55011 (EN 55022) class B used in industry and residential area / EMC 1



All technical specifications are nominal values and refer to a room temperature of 25 °C and 70 % relative humidity at 100 m above sea level.

5 Intended use

This power supply unit features IP20 protection and is intended for installation in housing. It is suitable for use in industrial applications.

6 Structure

6.1 Device elements

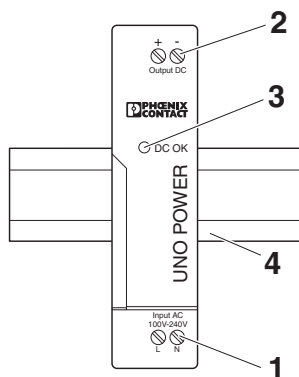

Figure 1 Device elements

1. Connection terminal block input voltage:
Input AC L/N
2. Connection terminal block output voltage:
Output DC +/-
3. LED signaling DC OK (green)
4. Integrated snap-on foot for carrier rail mounting

6.2 Block diagram

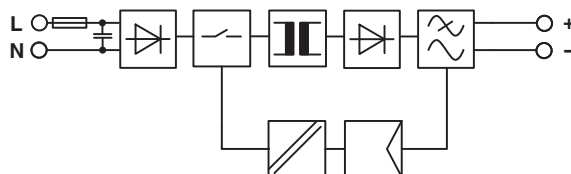









Figure 2 Block diagram

Element	Meaning
	Fuse
	Rectification
	Switch
	Transformer
	Filter
	Electrically isolated signal transmission
	Regulation

7 Mounting

7.1 Unpacking

Before mounting the power supply unit, it must be checked for damage:

- Take the device out of its packaging.
- Check the device for any damage sustained during transport.
- Retain the package slip for future use.
- Dispose of packaging in an environmentally-friendly way.

7.2 Mounting the power supply unit



The power supply unit is intended for installation in a distributor box or control cabinet.



The power supply unit is designed for convection cooling. Maintain a minimum distance from other devices in order to ensure convection cooling.

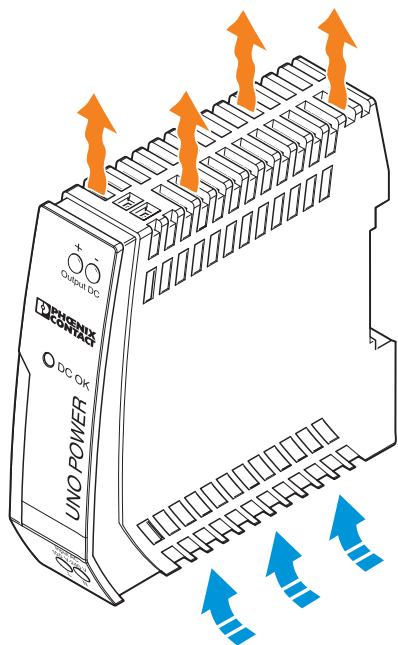

Figure 3 Convection

Please note the following before mounting the power supply unit:

- The minimum distance from other devices that must be observed in order to ensure convection cooling is: 30 mm vertically, 0 mm horizontally

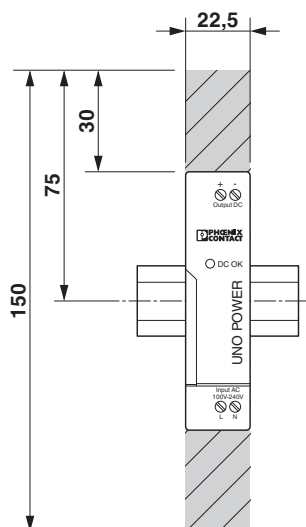

Figure 4 Device dimensions and dead surfaces

- The device dimensions

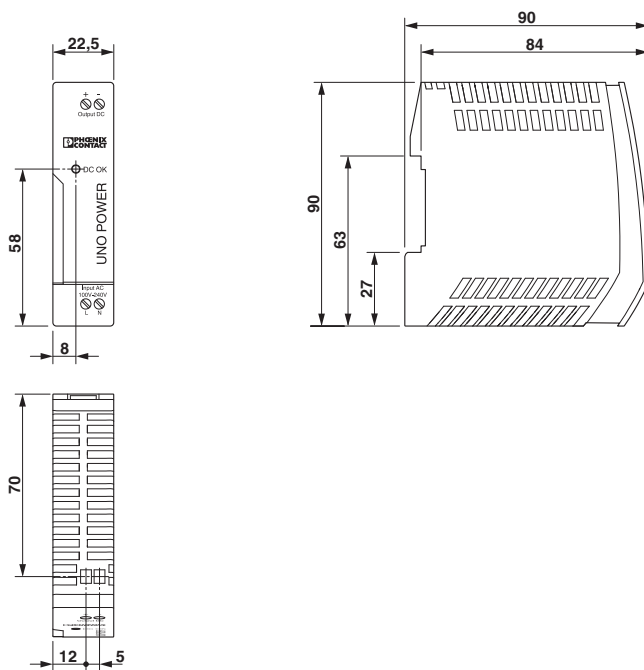

Figure 5 Device dimensions

7.3 Mounting on a DIN rail

The power supply unit can be installed on all 35 mm DIN rails according to EN 60715.

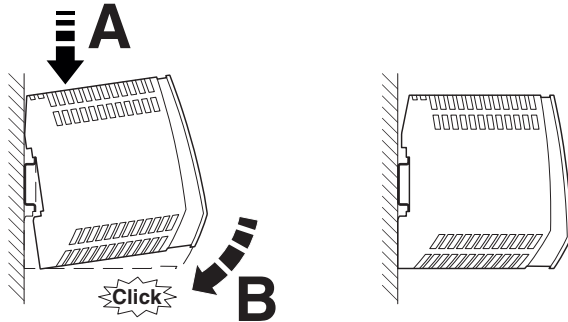

Figure 6 Mounting on a DIN rail

7.4 Normal mounting position

When installed, the input terminal blocks must be at the bottom and the output terminal blocks at the top.

If the power supply unit is installed in a mounting position other than the normal mounting position, the output power must be reduced.

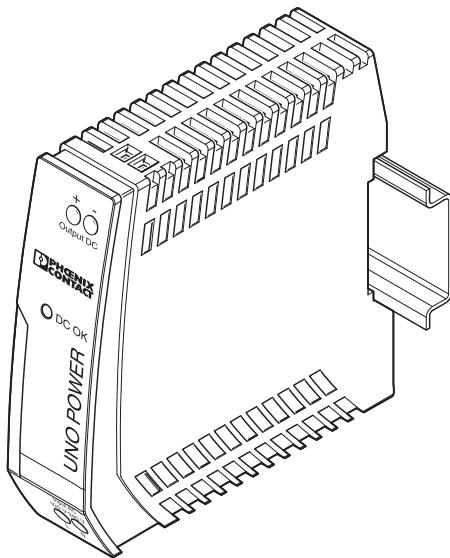

Figure 7 Normal mounting position

8 Installing the power supply unit

8.1 Safety regulations and installation notes



Before startup please ensure:

- Only skilled persons may install, start up, and operate the device.
- Observe the national safety and accident prevention regulations.



WARNING: Danger to life by electric shock!

- Never carry out work when voltage is present.
- Establish mains connection correctly and ensure protection against electric shock.
- The device must be switched off outside the power supply in accordance with the regulations of EN 60950-1 (e.g., by means of line protection on the primary side).
- Cover termination area after installation in order to avoid accidental contact with live parts (e. g., installation in control cabinet).
- Protect the device against foreign bodies penetrating it, e.g., paper clips or metal parts.



NOTE: Danger if used improperly

- The device is a built-in device.
- The IP20 degree of protection (IEC 60529/EN 60529) of the device is intended for use in a clean and dry environment. Do not subject the device to any load that exceeds the described limits.
- Observe mechanical and thermal limits.
- Ensure that the primary-side wiring and secondary-side wiring are the correct size and have sufficient fuse protection.



- It is not permissible to open or modify the device. Do not repair the device yourself but replace it with an equivalent device. Repairs may only be carried out by the manufacturer. The manufacturer is not liable for damage resulting from violation.
- The device may only be used for its intended use.

8.2 High-voltage test (HIPOT)

This protection class II power supply is subject to the Low Voltage Directive and is factory tested. During the HIPOT test (high-voltage test), the insulation between the input circuit and output circuit is tested for the prescribed electric strength values, for example. The test voltage in the high-voltage range is applied at the input and output terminal blocks of the power supply. The operating voltage used in normal operation is a lot lower than the test voltage used.



The test voltage should rise and fall in ramp form. The relevant rise and fall time of the ramp should be at least two seconds.

8.2.1 High-voltage dielectric test (dielectric strength test)

In order to protect the user, power supplies (as electric components with a direct connection to potentially hazardous voltages) are subject to more stringent safety requirements. For this reason, permanent safe electrical isolation between the hazardous input voltage and the touch-proof output voltage as safety extra-low voltage (SELV) must always be ensured.

In order to ensure permanent safe isolation of the AC input circuit and DC output circuit, high-voltage testing is performed as part of the safety approval process (type test) and manufacturing (routine test).

8.2.2 High-voltage dielectric test during the manufacturing process

During the manufacturing process for the power supply, a high-voltage test is performed as part of the dielectric test in accordance with the specifications of IEC/UL/EN 60950-1. The high-voltage test is performed with a test voltage of at least 3 kV AC / 4.3 kV DC or higher. Routine manufacturing tests are inspected regularly by a certification body.

8.2.3 High-voltage dielectric test performed by the customer

Apart from routine and type tests to guarantee electrical safety, the end user does not have to perform another high-voltage test on the power supply as an individual component. According to EN 60204-1 (Safety of machinery - Electrical equipment of machines) the power supply can be disconnected during the high-voltage test and only installed once the high-voltage test has been completed.

8.2.4 Performing high-voltage testing

If high-voltage testing of the control cabinet or the power supply as a stand-alone component is planned during final inspection and testing, the following features must be observed.

- The power supply wiring must be implemented as shown in the wiring diagram.
- The maximum permissible test voltages must not be exceeded.

Avoid unnecessary loading or damage to the power supply due to excessive test voltages.



For the relevant applicable test voltages and insulation distances, refer to the corresponding table (see technical data).

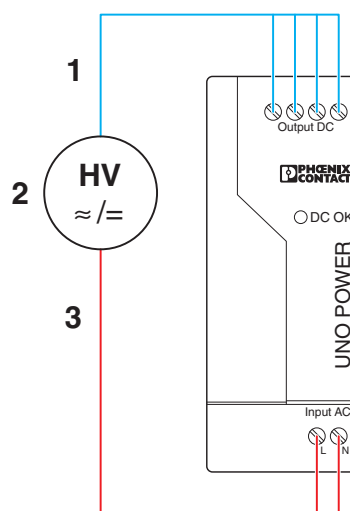

Figure 8 Potential-related wiring for the high-voltage test

Key

No.	Designation	Color coding	Potential levels
1	DC output circuit	Blue	Potential 2
2	High-voltage tester	--	--
3	AC input circuit	Red	Potential 1

8.3 Mains connection

The device can be connected to single-phase AC or three-phase power grids (TN-S, TN-C, TT, and IT) while considering the nominal input voltage.



For operation on two of the phase conductors of a three-phase system, an isolating facility for all poles must be provided.

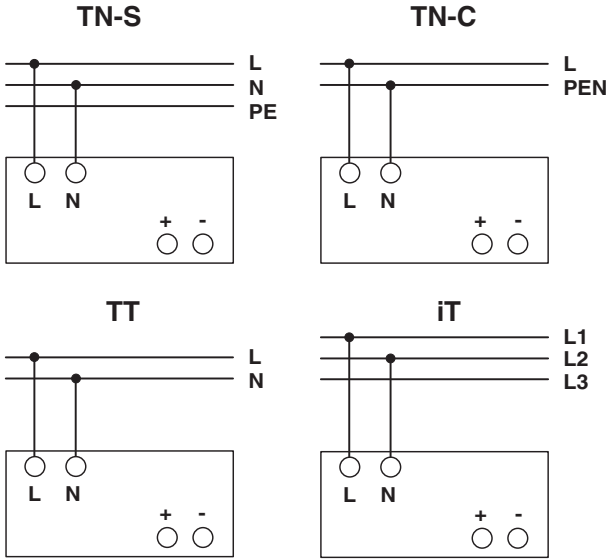

Figure 9 Network types

8.4 Device connections

Screw connection for input AC L/N

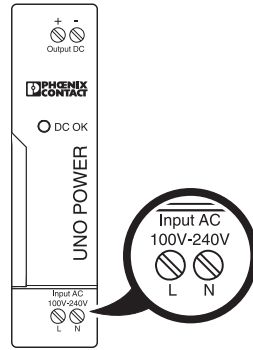

Figure 10 Screw connection for input AC L/N

Screw connection for output DC +/-

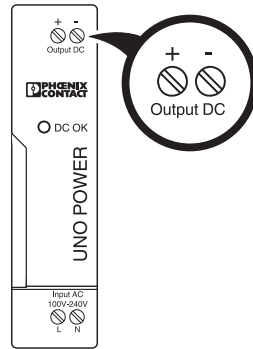

Figure 11 Screw connection for output DC +/-

8.5 Connecting cables



Use copper cables with an operating temperature $> 75^{\circ}\text{C}$ (ambient temperature $< 55^{\circ}\text{C}$) and $> 90^{\circ}\text{C}$ (ambient temperature $< 75^{\circ}\text{C}$).

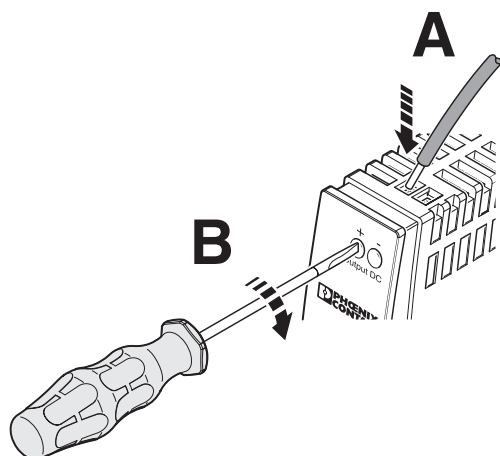

Figure 12 Connecting cables

1. Connect the supply lines to the input AC L/N connection terminal blocks.
2. Connect the output cables to the output DC +/- connection terminal blocks.

The power supply unit is operational as soon as the input terminal blocks are supplied with voltage.

9 Operating behavior of the power supply unit

9.1 Normal operation

In normal operation, the loads are supplied with a constant output voltage of 24 V DC.

9.2 Overload response

In the event of overload ($I > I_N$), the device reduces its output voltage. If the output voltage is greater than $U_N \times 0.9$, the green DC OK LED lights up. If the output voltage drops below $U_N \times 0.5$, the device shuts down. After a short time, the device attempts to start up again. If the overload has been rectified, it will start up as normal. If the overload has still not been rectified, it will shut down again and attempt to restart again (automatic restart).

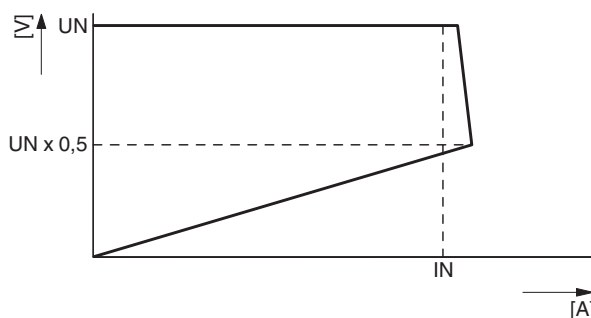

Figure 13 Output characteristic curve

9.3 Behavior at ambient temperatures $> 55^{\circ}\text{C}$

At an ambient temperature of up to 55°C , the power supply unit supplies the nominal output current. At ambient temperatures upwards of 55°C , the output power must be reduced by 2.5 % per Kelvin temperature increase (temperature-dependent derating).

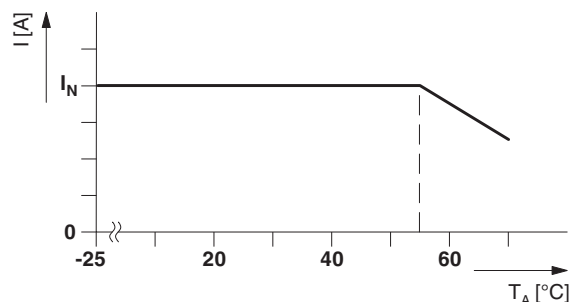

Figure 14 Temperature-dependent derating

9.4 Behavior in the case of alternative mounting positions

For mounting positions that differ from the normal mounting position, the output power must be reduced (position-dependent derating).

The characteristic curve can be used to determine the maximum output power to be drawn for each ambient temperature for different mounting positions.

Normal mounting position

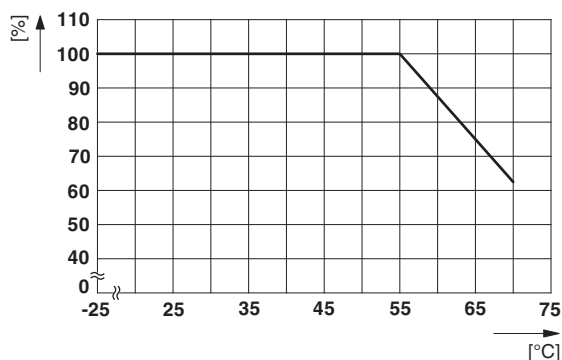
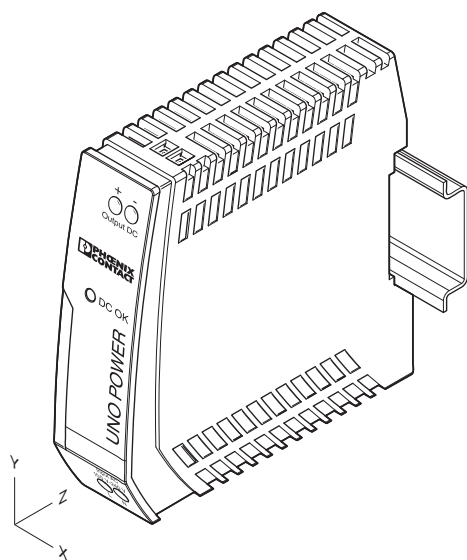

Rotated mounting position 90° X-axis

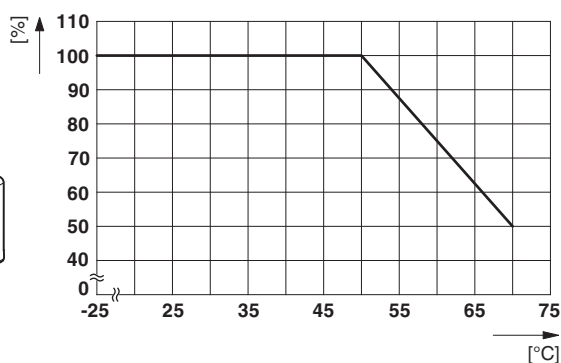
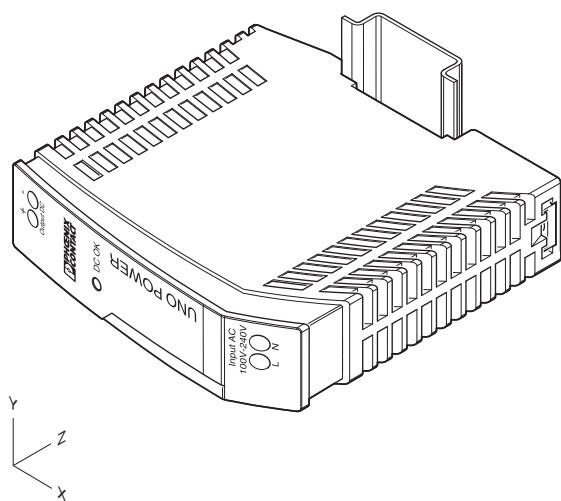

Rotated mounting position 180° X-axis

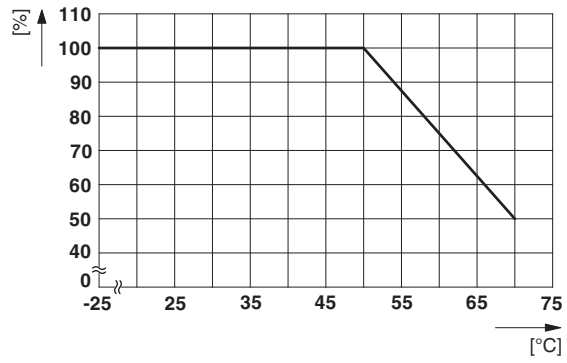
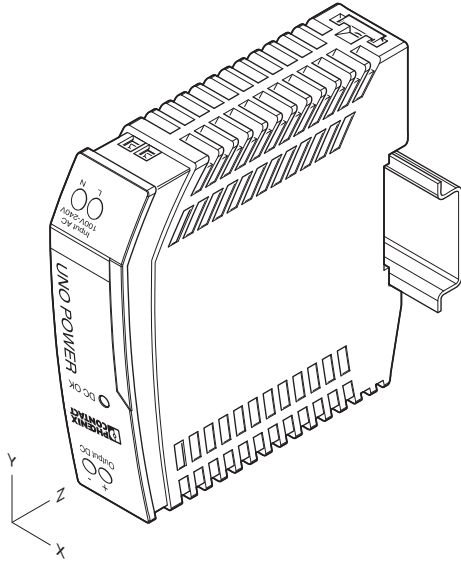

Rotated mounting position 270° X-axis

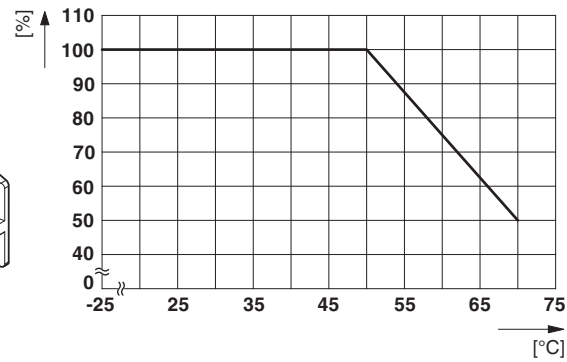
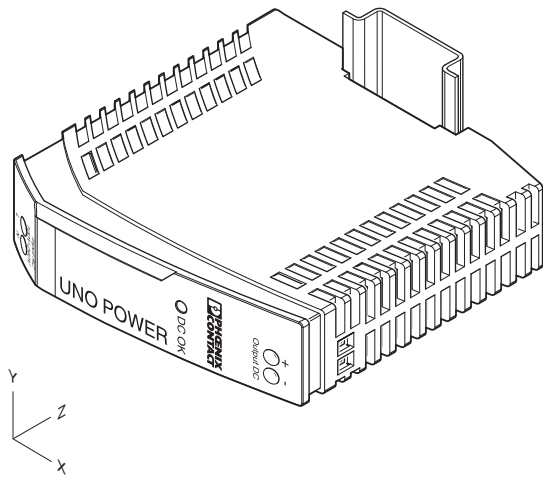

Rotated mounting position 90° Z-axis

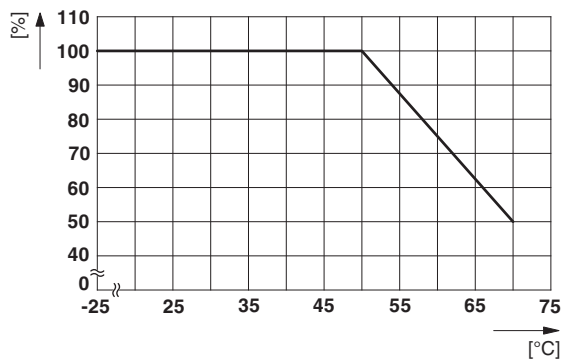
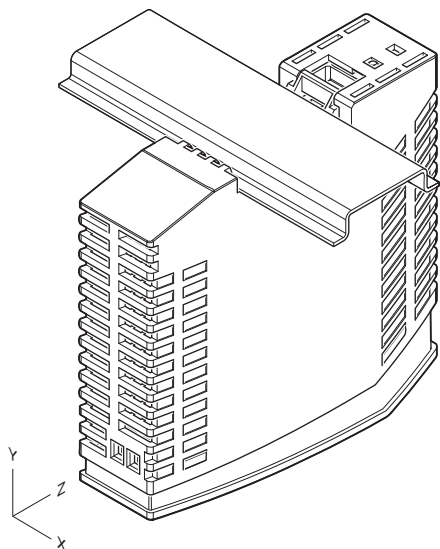

Rotated mounting position 270° Z-axis

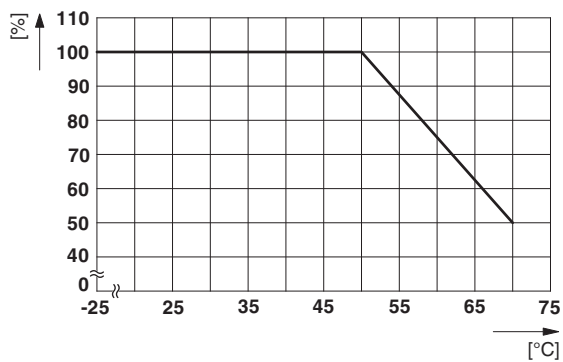
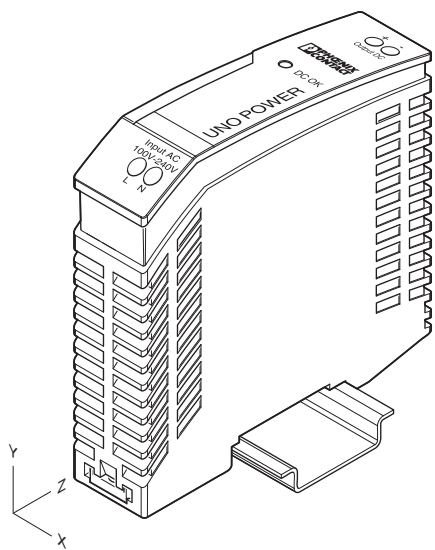

10 Operating the power supply unit

10.1 Function monitoring

DC OK LED

The DC OK LED is available for visual function monitoring of the power supply unit.

	Status 1	Status 2
DC OK LED	lit	off
Meaning	Output voltage > 21.5 V	Output voltage < 21.5 V DC, overload mode or no mains voltage
State description	The device is operating, output voltage and output current are OK	The device is in operation, but there is a fault on the side of the consumer; the current consumption is greater than IN or the output is short-circuited. The device is out of operation because there is no mains voltage, the fuse on the primary side has been triggered, or the device is faulty.
Corrective		Remove the error at the load, use a more powerful power supply unit, connect a power supply unit of the same type parallel to the existing device, remove the short circuit, apply mains voltage, enable the fuse again or replace the power supply unit.

10.2 Operating power supply units in parallel

Power supply units of the same type can be connected in parallel to increase both redundancy and power.



To ensure symmetrical current distribution, all cable connections from the power supply unit to the busbar must be the same length and have the same conductor cross section.

Redundant operation

Redundant circuits are suitable for supplying systems which place particularly high demands on operational safety. If a fault occurs in the primary circuit of the first power supply unit, the second device automatically takes over the complete power supply without interruption, and vice versa.

Using a redundancy module, it is possible for two power supply units of the same type that are connected in parallel on the output side for redundancy to be decoupled from one another.

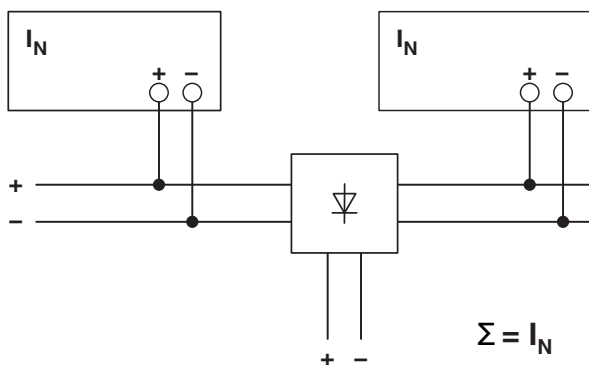

Figure 15 Redundant circuit with redundancy module

Increased performance

Power supply units of the same type can be connected in parallel to increase the power to $n \times I_N$. Parallel connection is recommended if existing systems are to be extended and the power supply unit that is installed here does not cover the current consumption of the most powerful load. Otherwise, the loads should be distributed between individual devices that are independent of one another.

Using a redundancy module, it is possible for two power supply units of the same type that are connected in parallel on the output side to increase power to be decoupled from one another.

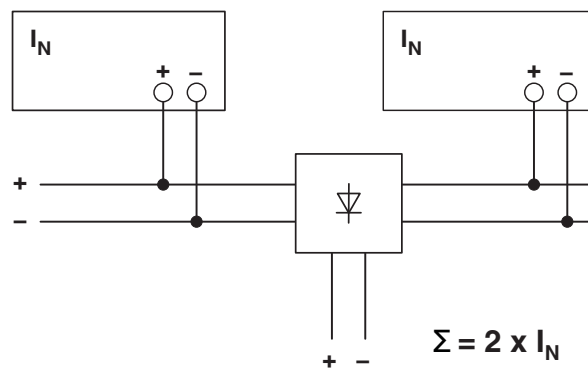

Figure 16 Parallel connection to increase power with a redundancy module

10.3 Operating the power supply unit in series

Two devices can be connected in series to double the voltage. Only power supply units of the same type should be connected in series. Series connection should always be used when the output voltage of the module is not sufficient. For example, devices with 24 V DC nominal output voltage each supply 48 V DC in series. Depending on the specification of functional earth ground, output voltages of + 48 V/-48 V as well as ± 24 V DC can also be made available.

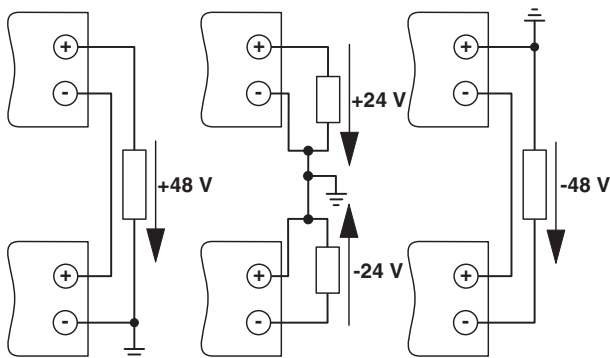

Figure 17 Series operation

11 Removal

11.1 Removing the power supply unit

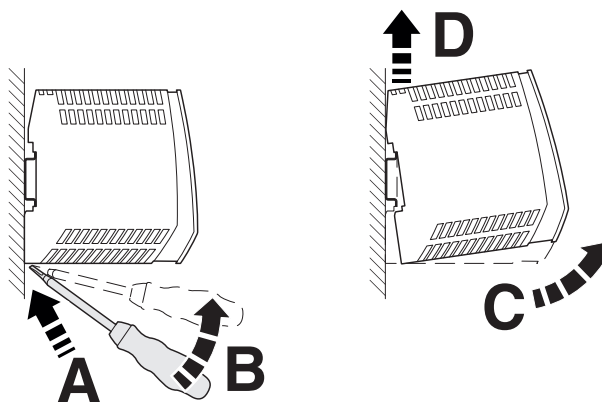

Figure 18 Removal

11.2 Notes on disposal



Do not dispose of the power supply unit with household waste. It should be disposed of in accordance with the currently applicable national regulations.



SCATTERGOOD & JOHNSON LTD

ELECTRICAL ENGINEERING & FLUID CONTROL DISTRIBUTORS

Est.1899

At Scattergood & Johnson Ltd, we pride ourselves on being a technical distributor to specialist industries.

Working with a range of quality product suppliers across a number of specialist markets, we are not your average 'box shifter' - we are your technical and supply chain partner.

We fully support every product we sell - for free! Our internal team and external sales engineers can answer any product or application question, no matter the complexity.

Backing up this technical ability is a range of 50,000+ products available from stock for nationwide next day delivery (same day if required!), or you can collect what you need from any of our trade counters around the UK.

Select your specialist interest below to learn more about how we can help.

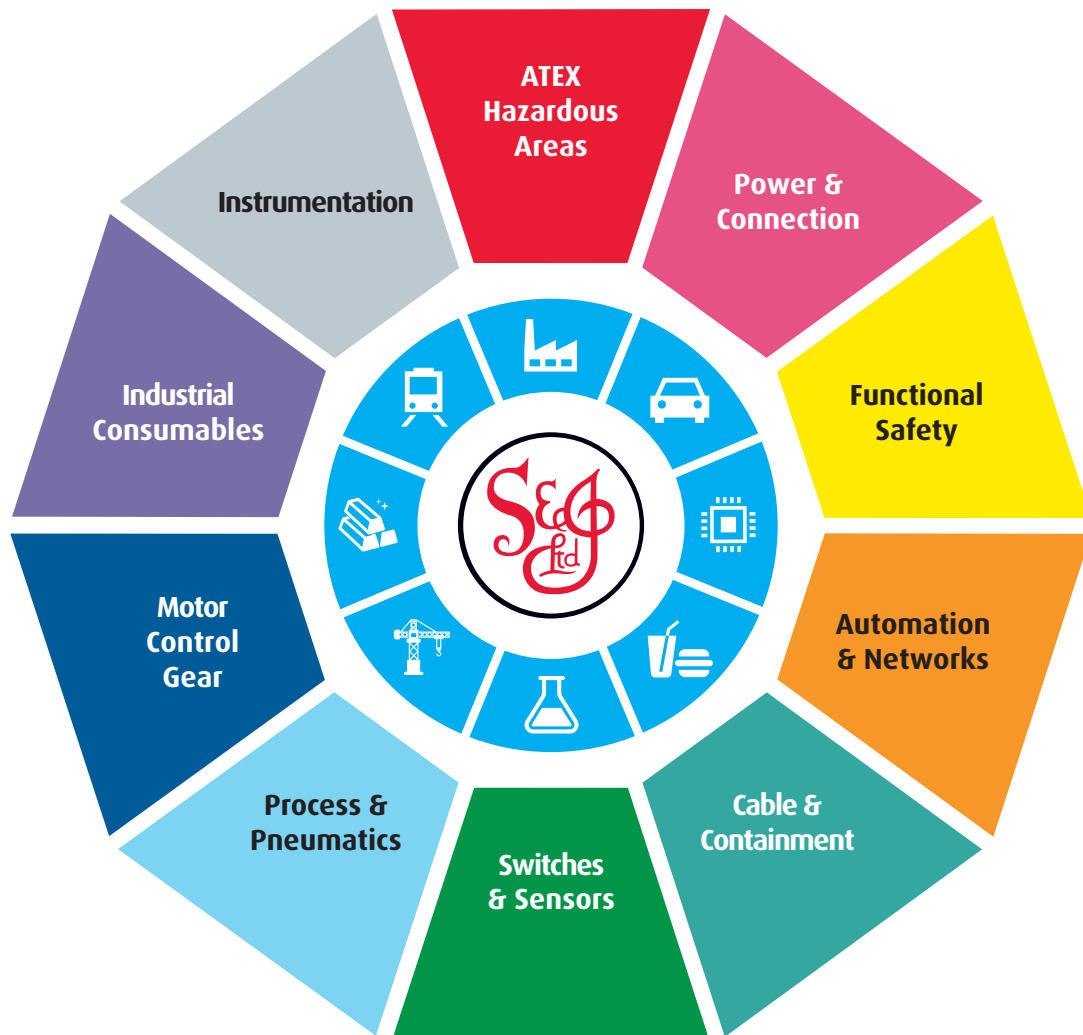

Online, In Branch and On the Road - Scattergood & Johnson Ltd, there when you need us.

www.scatts.co.uk