

TRIO-PS-2G/1AC/24DC/10

Power supply unit

Data sheet

105901_en_00

© PHOENIX CONTACT 2015-08-31



1 Description

TRIO POWER - power supplies with standard functionality
The power supplies of the TRIO POWER family convince due to their slim and robust design. The dynamic boost (1.5 x I_N for 5 seconds) absorbs starting currents and short overload situations securely during operation and without a drop in output voltage. The push-in connection technology on the front enables fast and tool-free wiring of the devices.

Features

- Especially slim design
- Worldwide use, thanks to wide-range input
- Safe operation, thanks to electrically and mechanically robust design
- Reliable starting of heavy loads, thanks to dynamic boost (1.5 x I_N for 5 seconds)
- Simplified error diagnostics for remote signaling via DC-OK signal contact
- OVP (Over Voltage Protection) limits surge voltages to ≤ 30 V (EN61131-2)
- Tool-free connection via push-in connection technology

Technical data (short form)

Nominal input voltage range	100 V AC ... 240 V AC 110 V DC ... 250 V DC
Frequency range	50 Hz ... 60 Hz
Nominal output voltage	24 V DC ± 1 %
> 24 V DC, constant capacity restricted	24 V DC ... 28 V DC
Nominal output current I _N / I _{Dyn}	10 A / 15 A (5 s)
Residual ripple	≤ 10 mV _{PP}
Protection against surge voltage on the output	≤ 30 V DC
MTBF (IEC 61709, SN 29500)	> 1800000 h (25 °C) > 1000000 h (40 °C) > 480000 h (60 °C)
Efficiency for 230 V AC and nominal values	> 91 %
Maximum power dissipation NO-Load	< 5.1 W
Power loss nominal load max.	< 25 W
Ambient temperature (operation)	-25 °C ... 70 °C > 60 °C Derating: 2,5 %/K
Ambient temperature (start-up type tested)	-40 °C
Weight	1 kg
Dimensions W/H/D	42 mm / 130 mm / 160 mm



Make sure you always use the latest documentation.
It can be downloaded from the product at phoenixcontact.net/products.

2	Table of contents	
1	Description	1
2	Table of contents	2
3	Ordering data	3
4	Technical data	3
5	Safety regulations and installation notes.....	7
6	Basic circuit diagram	7
7	Structure	8
8	Cooling	8
9	Mounting position and dimensions	9
	9.1 Mounting position	9
	9.2 Device dimensions.....	10
10	Mounting/removal.....	11
	10.1 Assembly.....	11
	10.2 Removal.....	11
11	Device connection terminal blocks	11
	11.1 Push-in connection technology	11
12	Input	12
	12.1 Position of input terminals	12
	12.2 Protection of the primary side	12
13	Output.....	13
	13.1 Position of output terminals	13
	13.2 Protection of the secondary side.....	13
	13.3 Output characteristic curve.....	13
14	Dynamic boost.....	14
15	Signaling.....	14
	15.1 DC OK-LED	14
	15.2 Floating signal contact	14
16	Derating.....	15
	16.1 Temperature-dependent derating	15
	16.2 Position-dependent derating.....	16
17	Operating modes	19
	17.1 Series operation	19
	17.2 Parallel operation.....	19
	17.3 Redundant operation	19
	17.4 Increasing power	20

3 Ordering data

Description	Type	Order No.	Pcs./Pkt.
Primary-switched TRIO POWER power supply with push-in connection for DIN rail mounting, input: single phase, output: 24 V DC/10 A	TRIO-PS-2G/1AC/24DC/10	2903149	1
Accessories	Type	Order No.	Pcs./Pkt.
Multi-channel, electronic device circuit breaker with active current limitation for protecting four loads at 24 V DC in the event of overload and short circuit. With nominal current assistant and electronic locking of the set nominal currents. For installation on DIN rails.	CBM E4 24DC/0.5-10A NO-R	2905743	1
Multi-channel, electronic device circuit breaker with active current limitation for protecting eight loads at 24 V DC in the event of overload and short circuit. With nominal current assistant and electronic locking of the set nominal currents. For installation on DIN rails.	CBM E8 24DC/0.5-10A NO-R	2905744	1
VARIOFACE module, with two equipotential busbars (P1, P2) for potential distribution, for mounting on NS 35 rails. Module width: 70.4 mm	VIP-2/SC/PDM-2/24	2315269	1
VARIOFACE module with push-in connection and two equipotential busbars (P1, P2) for potential distribution, for mounting on NS 35 rails. Module width: 57.1 mm	VIP-3/PT/PDM-2/24	2903798	1



Our range of accessories is being continually extended, our current range can be found in the download area.

4 Technical data

Input data	
Nominal input voltage range (for DC, connect a suitable fuse)	100 V AC ... 240 V AC -15 % ... +10 % 110 V DC ... 250 V DC
Input voltage range	85 V AC ... 264 V AC 99 V DC ... 275 V DC
Electric strength, max.	≤ 300 V AC 15 s
Current consumption (for nominal values)	3.1 A (100 V AC) 1.4 A (240 V AC) 2.5 A (110 V DC) 1.1 A (250 V DC)
Frequency	50 Hz ... 60 Hz
Inrush current limitation (at 25°C)	≤ 25 A (typical)
Inrush surge current I^2t	< 0.5 A ² s
Input fuse internal (device protection)	6.3 A
Mains buffering	> 15 ms (120 V AC) > 15 ms (230 V AC)
A choice of suitable fuses	6 A ... 16 A (Characteristics B, C, D, K)
Input connection data	
Connection method	Push-in connection
Conductor cross section, solid	0.2 mm ² ... 4 mm ²
Conductor cross section, flexible	0.2 mm ² ... 2.5 mm ²
Cross section AWG	24 ... 12
Stripping length	10 mm

Output data

Nominal output voltage	24 V DC $\pm 1\%$
Setting range of the output voltage	24 V DC ... 28 V DC (> 24 V DC, constant capacity restricted)
Output current	10 A 15 A (5 s)
Control deviation	< 1 % (change in load, static 10 % ... 90 %) < 3 % (Dynamic load change 10 % ... 90 %, 10 Hz) < 0.1 % (change in input voltage $\pm 10\%$)
Efficiency	> 91 % (for 230 V AC and nominal values)
Rise time	≤ 12 ms (U_{OUT} (10 % ... 90 %))
Residual ripple	≤ 10 mV _{PP}
Connection in parallel	Yes, for redundancy and increased capacity
Connection in series	Yes
Protection against surge voltage on the output	≤ 30 V DC

Output connection data

Connection method	Push-in connection
Conductor cross section, solid	0.2 mm ² ... 4 mm ²
Conductor cross section, flexible	0.2 mm ² ... 2.5 mm ²
Conductor cross section AWG	24 ... 12
Stripping length	8 mm

Signaling DC OK

Types of signaling	LED, floating signal contact
Signal threshold	$U_{OUT} < 0.9 \times U_N$
Type of signaling	LED
Status indicator	green
Type of signaling	Switch contact
Maximum switching voltage	30 V AC/DC
Continuous load current	100 mA

Signal connection data

Connection method	Push-in connection
Conductor cross section, solid	0.2 mm ² ... 1.5 mm ²
Conductor cross section, flexible	0.2 mm ² ... 1.5 mm ²
Conductor cross section AWG	24 ... 16
Stripping length	8 mm

General data

Insulation voltage input/output	4 kV AC (type test) 1.5 kV AC (routine test)
Degree of protection	IP20
Protection class	I (in closed control cabinet)
Inflammability class in acc. with UL 94 (housing)	V0
MTBF (IEC 61709, SN 29500)	> 1800000 h (25 °C) > 1000000 h (40 °C) > 480000 h (60 °C)
Type of housing	Aluminum (AlMg3)
Hood version	Polycarbonate
Dimensions W / H / D (state of delivery)	42 mm / 130 mm / 160 mm
Weight	1 kg

Power consumption

Maximum power dissipation NO-Load	< 5.1 W
Power loss nominal load max.	< 25 W

Ambient conditions

Ambient temperature (operation)	-25 °C ... 70 °C (> 60 °C Derating: 2,5 %/K)
Ambient temperature (start-up type tested)	-40 °C
Ambient temperature (storage/transport)	-40 °C ... 85 °C
Max. permissible relative humidity (operation)	≤ 95 % (at 25 °C, non-condensing)
Maximum altitude	≤ 5000 m (> 2000 m, observe derating)
Vibration (operation)	< 15 Hz, amplitude ±2.5 mm (according to IEC 60068-2-6) 15 Hz ... 150 Hz, 4g, 90 min.
Shock	30g in each direction, according to IEC 60068-2-27
Pollution degree	2
Climatic class	3K3 (in acc. with EN 60721)

Standards

Electrical Equipment for Machinery	EN 60204-1
Electrical safety (of information technology equipment)	IEC 60950-1/VDE 0805 (SELV)
Electronic equipment for use in electrical power installations	EN 50178/VDE 0160 (PELV)
SELV	IEC 60950-1 (SELV) and EN 60204-1 (PELV)
Safe isolation	DIN VDE 0100-410
Limitation of mains harmonic currents	EN 61000-3-2
Network version/undervoltage	Semi F47-0706
Rail applications	EN 50121-4

Approvals

UL	UL Listed UL 508 UL/C-UL Recognized UL 60950-1
----	---



Current approvals/permissions for the product can be found in the download area under phoenixcontact.net/products.

Conformance with EMC Directive 2004/108/EC**Noise immunity according to EN 61000-6-2**

	EN 61000-6-2 requirement	Tested
Electrostatic discharge EN 61000-4-2		
Housing contact discharge	4 kV (Test intensity 2)	6 kV (Test intensity 4)
Housing air discharge	8 kV (Test intensity 3)	8 kV (Test intensity 4)
Comments	Criterion B	Criterion A
Electromagnetic HF field EN 61000-4-3		
Frequency range	80 MHz ... 1 GHz	80 MHz ... 1 GHz
Test field strength	10 V/m (Test intensity 3)	10 V/m (Test intensity 3)
Frequency range	1.4 GHz ... 2 GHz	1 GHz ... 2 GHz
Test field strength	3 V/m (Test intensity 2)	10 V/m (Test intensity 3)
Frequency range	2 GHz ... 2.7 GHz	2 GHz ... 3 GHz
Test field strength	1 V/m (Test intensity 1)	10 V/m (Test intensity 3)
Comments	Criterion A	Criterion A
Fast transients (burst) EN 61000-4-4		
Input	2 kV (Test intensity 3 - asymmetrical)	4 kV (Test intensity 4 - asymmetrical)
Output	2 kV (Test intensity 3 - asymmetrical)	2 kV (Test intensity 3 - asymmetrical)
Signal	1 kV (Test intensity 1 - asymmetrical)	1 kV (Test intensity 2 - asymmetrical)
Comments	Criterion B	Criterion A
Surge current loads (surge) EN 61000-4-5		
Input	1 kV (Test intensity 1 - symmetrical) 2 kV (Test intensity 1 - asymmetrical)	3 kV (Test intensity 3 - symmetrical) 6 kV (Test intensity 4 - asymmetrical)
Output	0.5 kV (Test intensity 1 - symmetrical) 0.5 kV (Test intensity 1 - asymmetrical)	1 kV (Test intensity 2 - symmetrical) 2 kV (Test intensity 1 - asymmetrical)
Signal	1 kV (Test intensity 2 - asymmetrical)	1 kV (Test intensity 2 - asymmetrical)
Comments	Criterion B	Criterion B
Conducted interference EN 61000-4-6		
Input/output	asymmetrical	asymmetrical
Frequency range	0.15 MHz ... 80 MHz	0.15 MHz ... 80 MHz
Voltage	10 V (Test intensity 3)	10 V (Test intensity 3)
Comments	Criterion A	Criterion A

Key

Criterion A	Normal operating behavior within the specified limits.
Criterion B	Temporary impairment to operational behavior that is corrected by the device itself.

Emitted interference in acc. with EN 61000-6-3

Radio interference voltage in acc. with EN 55011	EN 55011 (EN 55022) Class B, area of application: Industry and residential
Emitted radio interference in acc. with EN 55011	EN 55011 (EN 55022) Class B, area of application: Industry and residential



All technical specifications are nominal and refer to a room temperature of 25 °C and 70% relative humidity at 2000 m above sea level.

5 Safety regulations and installation notes



Before startup please ensure:

- Installation and startup may only be carried out by qualified personnel.
- The relevant country-specific regulations must be observed.



NOTE: Danger if used improperly

- The device is a built-in device.
- The IP20 degree of protection (IEC 60529/EN 60529) of the device is intended for use in a clean and dry environment. Do not subject the device to any load that exceeds the described limits.
- Do not subject the device to mechanical and/or thermal loads that exceed the specified limits.
- It is not permissible to open or modify the device. Do not repair the device yourself but replace it with an equivalent device. Repairs may only be carried out by the manufacturer. The manufacturer is not liable for damage resulting from violation.



CAUTION:

Before startup please ensure:

- Connection must be performed by specialist personnel and protection against electric shock ensured.
- It must be possible to switch off the device outside the power supply according to the regulations in EN 60950-1 (e.g., by line protection on the primary side).
- All feed lines are sufficiently protected and dimensioned!
- All output lines are dimensioned according to the maximum output current of the device or separately protected!
- Sufficient convection is guaranteed!



EXPLOSION HAZARD!

Only remove equipment when it is disconnected and not in the potentially explosive area.

DANGER

Never carry out work on live parts!
The housing can become very hot, depending on the ambient temperature and load!

6 Basic circuit diagram

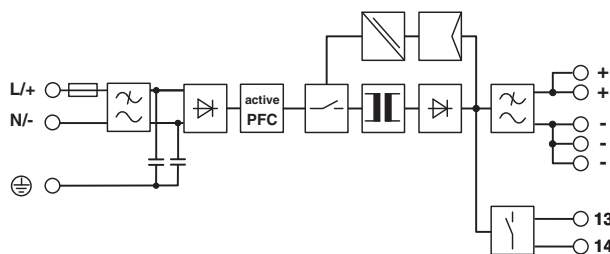

Figure 1 Block diagram

Key:	
	Rectification
	Power factor correction filter
	Switch
	Electrically isolated signal transmission
	Regulation
	Transformer
	Filter
	Floating switching output

7 Structure

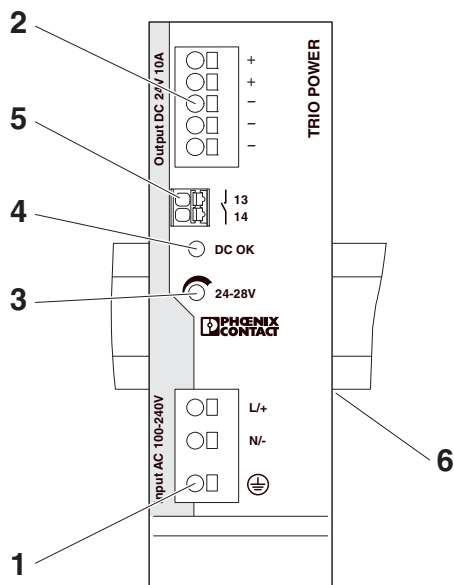

Figure 2 Function elements

No.	Description of the function elements
1.	Connection terminal block input voltage: Input L/N/PE
2.	Connection terminal block output voltage: Output DC +/-
3.	Potentiometer, output voltage: 24 V DC ... 28 V DC
4.	Signaling DC OK LED
5.	Floating signal contact: max. 30 V AC/DC, 100 mA
6.	Integrated universal snap-on foot

8 Cooling

Heat is dissipated from the power supply via the heatsinks integrated into the housing surfaces. Convection to dissipate heat from the power supply only takes place in small dimensions above the housing openings.

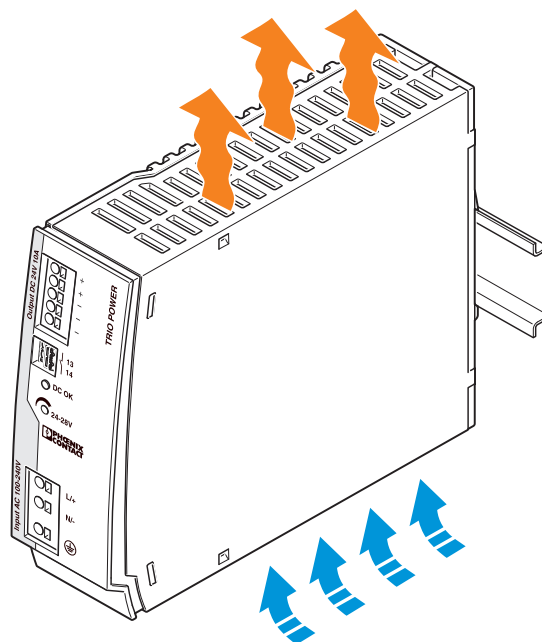

Figure 3 Convection



The power supply can be aligned without minimum lateral clearance up to an ambient temperature of 40°C. In a temperature range up to ≤ 70°C, a lateral minimum clearance of 10 mm between two active components (e.g., power supply) is required.



The device can be snapped onto all DIN rails in accordance with EN 60715 and should be mounted in the normal mounting position.



To ensure sufficient wiring space to wire the power supply, we recommend a vertical minimum clearance from other devices of 50 mm. Depending on the cable duct used, a smaller clearance may be possible.

9 Mounting position and dimensions

9.1 Mounting position

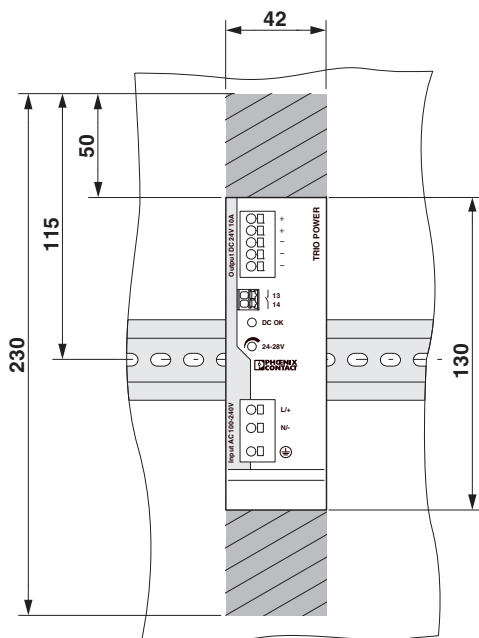

Figure 4 Locked areas

Possible mounting positions:

Normal mounting position, installation depth 160 mm (+ DIN rail)

9.2 Device dimensions

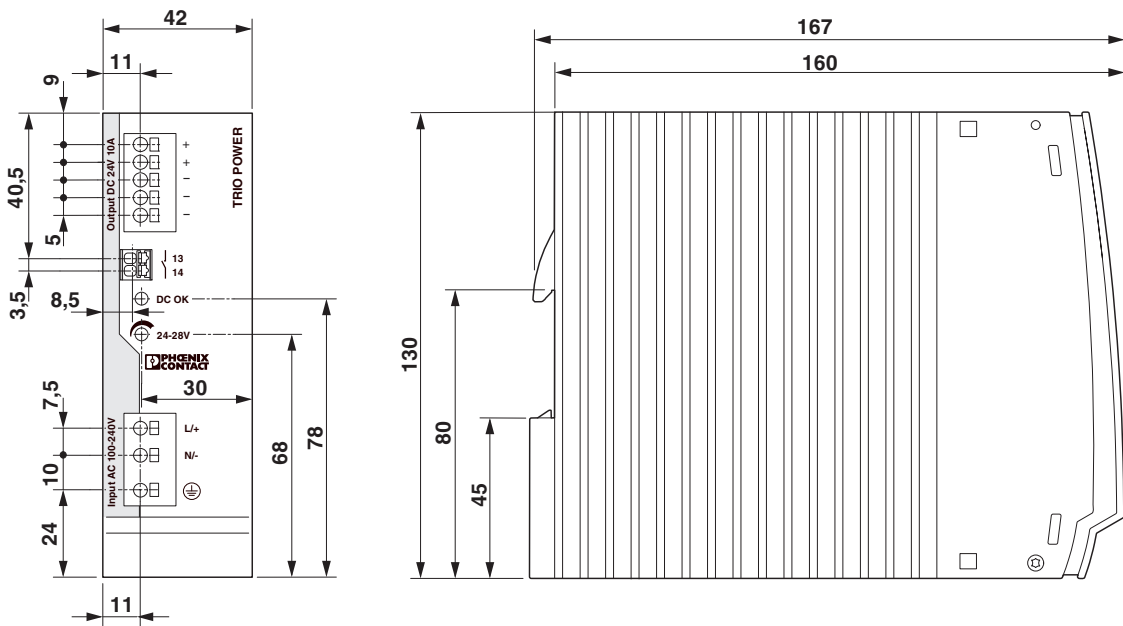

Figure 5 Device dimensions

10 Mounting/removal

10.1 Assembly

Position the module with the DIN rail guide on the upper edge of the DIN rail, and snap it in with a downward motion.

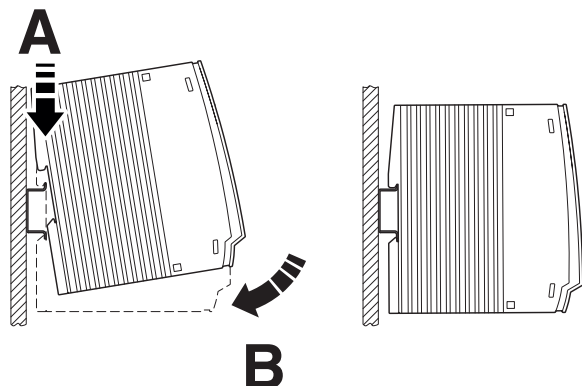

Figure 6 Assembly on standard DIN rail

10.2 Removal

Pull the snap lever open with the aid of a screwdriver and slide the module out at the lower edge of the DIN rail.

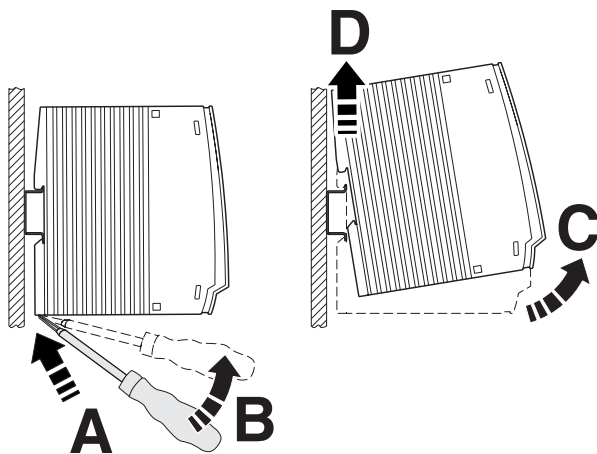

Figure 7 Removing the DIN rail

11 Device connection terminal blocks

11.1 Push-in connection technology

All connection terminal blocks on the power supply have push-in connection technology on the front. The power supply is wired by simply plugging in the connecting cables, no tools are required. For the necessary connection parameters for the terminal blocks, please refer to the technical data.

11.1.1 Plug in connecting cable

The wiring is carried out by simply plugging the connecting cable into the contact opening provided. Insert the connecting cable as far as it will go.

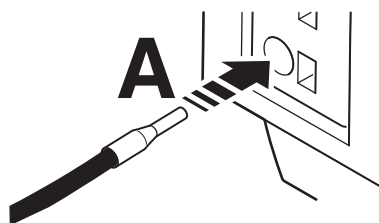

Figure 8 Insert connecting cable (push-in connection technology)

11.1.2 Loosen the connecting cable

To disconnect the wiring, take a suitable screwdriver and insert it into the opening for release. Then carefully pull the connecting cable out of the contact opening.

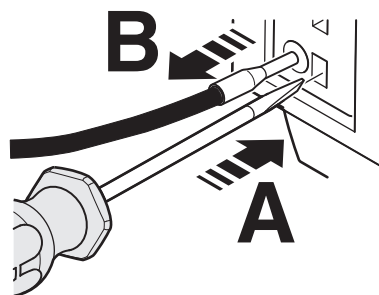

Figure 9 Release connecting cable (push-in connection technology)

12 Input

For operation on two of the phase conductors of a three-phase system, an isolating facility for all poles must be provided.

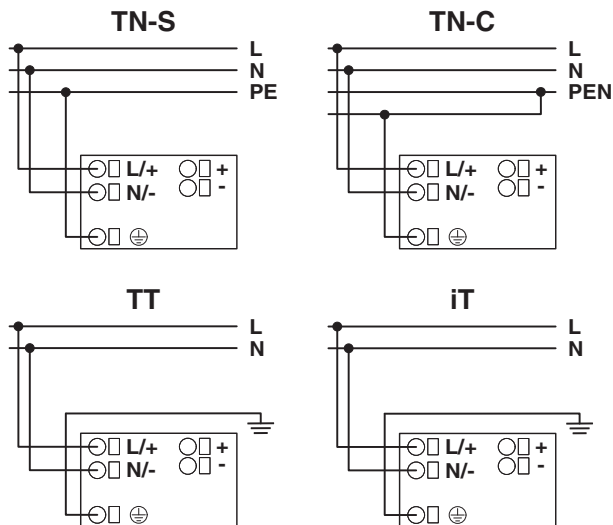

Figure 10 Network types

12.1 Position of input terminals

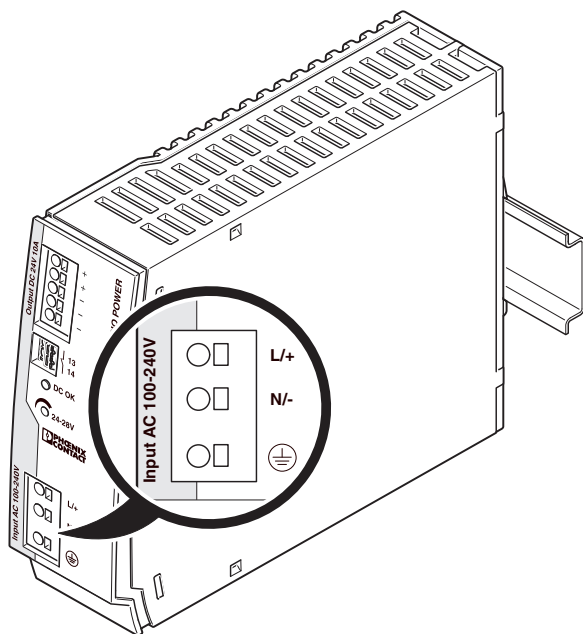

Figure 11 Position of input terminals

12.2 Protection of the primary side

Installation of the device must correspond to EN 60950 regulations. It must be possible to disconnect the device from the voltage using a suitable separator outside the power supply. For example, the primary-side line protection is suitable for this (see technical data).

An internal, approved AC/DC fuse is available as device protection. Additional device protection is not required.



If an internal fuse trips, this is due to a device fault. In this case, the device must be inspected in the factory. Opening the device or repairing it yourself is prohibited.

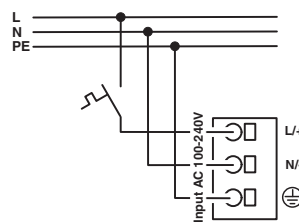

Figure 12 Schematic diagram, switching the input terminals

13 Output

A DC voltage for supplying the load is provided at the output of the power supply. The load is connected via the OUTPUT +/- connection terminal blocks.

By default, the power supply is pre-set to a nominal output voltage of 24 V DC.

The output voltage can also be set to the range from 24 V DC to 28 V DC using the potentiometer in order to compensate for a possible voltage drop due to the long cable lengths between the power supply and the load to be supplied.

13.1 Position of output terminals

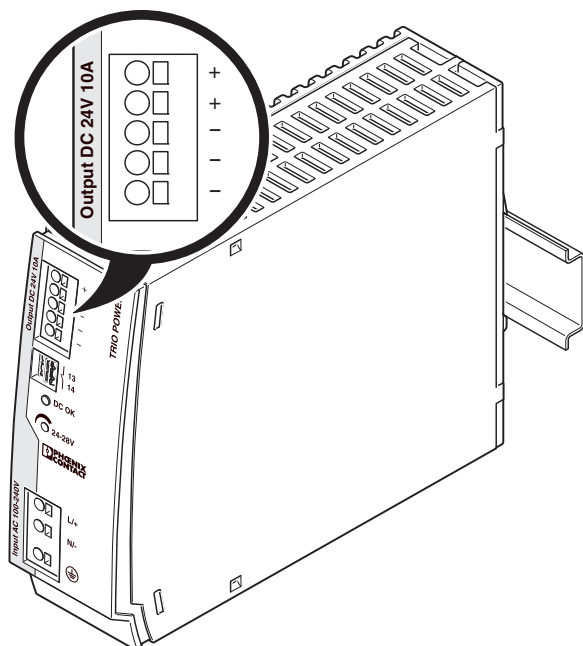

Figure 13 Position of output terminals

13.2 Protection of the secondary side

The power supply is electronically short-circuit-proof and idling-proof. In the event of an error, the output voltage is limited. It must be ensured that all output cables are dimensioned accordingly for the maximum output current or have separate protection.

The connecting cables on the secondary side should have large cross sections to keep the voltage drops in the cables as low as possible.

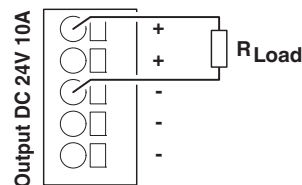

Figure 14 Schematic diagram, switching the output terminals

13.3 Output characteristic curve

The power supply works with a dynamic power reserve, the dynamic boost, as shown in the U/I characteristic curve in the figure. In the event of a secondary-side short circuit or overload, the output current is limited to $1.5 \times I_N$. The module does not switch off, but supplies a continuous output current instead. The secondary voltage is then reduced until the short circuit is eliminated. The U/I characteristic curve with the dynamic power reserve enables high switch-on currents of capacitive loads or inductive loads to be supplied reliably.

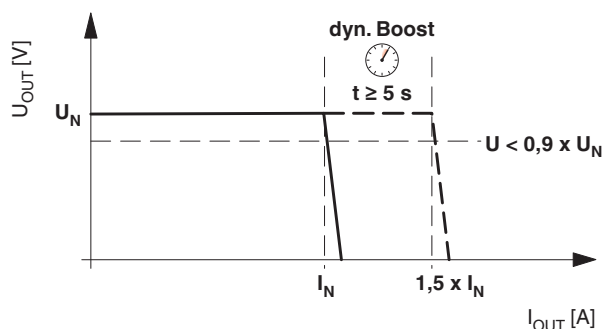

Figure 15 U/I characteristic curve with dynamic load reserve

- $U_N = 24 \text{ V}$
- $I_N = 10 \text{ A}$
- $I_{\text{dyn. BOOST}} = 15 \text{ A}$
- $P_N = 240 \text{ W}$
- $P_{\text{dyn. BOOST}} = 360 \text{ W}$

14 Dynamic boost

The following example is used to explain how the power supply dynamic boost functions.

Example:

The power supply supplies a connected base load of 80% until time point t_1 (see illustration, schematic diagram of the dynamic boost behavior). If an additional load is activated while the power supply is in operation, the dynamic boost is requested for the period of time t_1 to t_2 . The power supply provides the maximum dynamic power reserve of an additional 70% ($\Delta P_{\text{dyn. Boost}} = 1.5 \times I_N \times U_N - P_{\text{Initial load}}$).

As such, the requested overall total power corresponds to 150% of the nominal power. This power can be accessed directly for at least 5 s in the event that the output voltage remains the same. On reaching time point t_2 , the dynamic boost is once more returned to the output value of the base load for thermal offloading of the power supply. In this case, the base load amounts to the same value of 80%, as prior to time point t_1 . If the request to supply the load still exists, when the time intervals t_2 to t_3 have expired (at least 7 s), a new cyclical switching of the dynamic power reserve occurs, to a total of 70%.

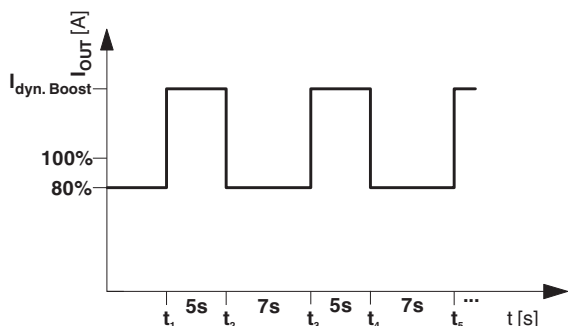

Figure 16 Schematic diagram of dynamic boost behavior



Depending on the connected base load, the power supply firmware determines the time intervals for the dynamic boost procedure or the time required for the release of thermal tension. The ratio of dynamic boost time and time for thermal tension release always varies, depending on load.

15 Signaling

15.1 DC OK-LED

The DC OK-LED is available for function monitoring. The LED is continuously illuminated when the output voltage is > 90 % of the nominal output voltage U_{OUT} (24 V DC).

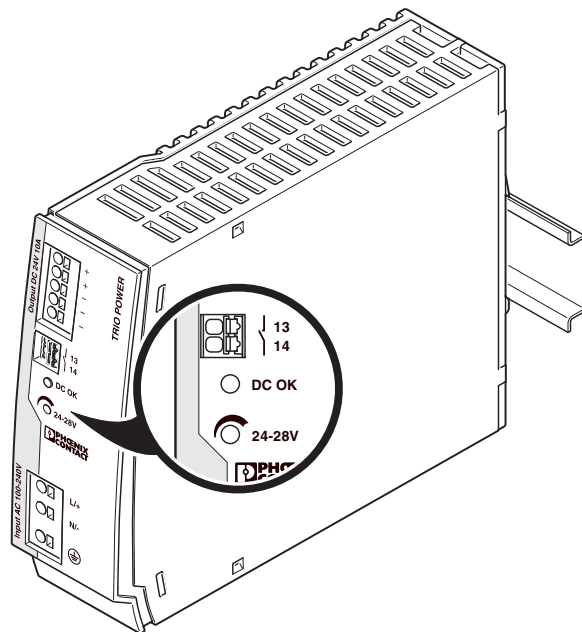

Figure 17 Location of the elements

15.2 Floating signal contact

A floating diagnostics contact can be used to forward data to a higher-level control system. When opened, the diagnostics contact indicates an underrange of more than 90% for the nominal output voltage U_{OUT} .

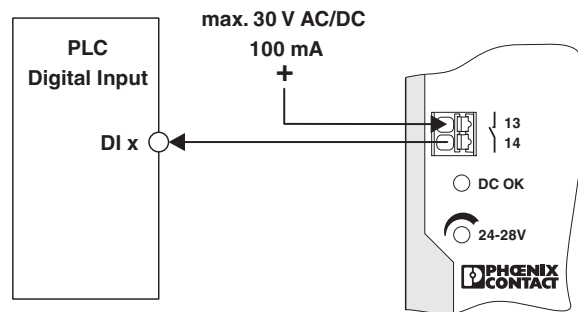

Figure 18 Wiring principle

16 Derating

16.1 Temperature-dependent derating

The device provides both the I_N nominal output current and the $I_{\text{dyn. BOOST}}$ dynamic output current at ambient temperatures up to +60 °C. For ambient temperatures above +60 °C, the ambient power must be decreased by 2.5% per Kelvin increase in temperature. For ambient temperatures above +70 °C or in the event of a thermal overload, the device does not switch off. The output power will be decreased by enough to allow device protection. Once the device has cooled down, the output power will be increased again.

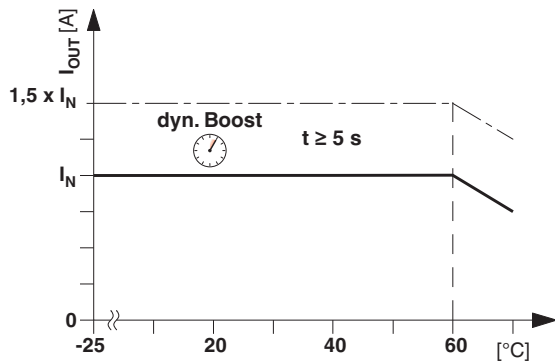

Figure 19 Temperature derating in normal mounting position

16.2 Position-dependent derating

The power supply can be installed onto all 35 mm DIN rails according to EN 60175. The normal mounting position of the power supply is horizontal.

When installing in a different mounting position, derating should be adhered to.

The characteristic curve can be used to determine the maximal output power to be drawn for each ambient temperature for different mounting positions.

Normal mounting position

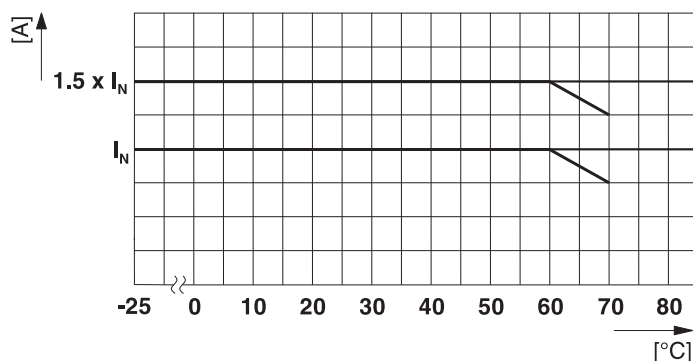
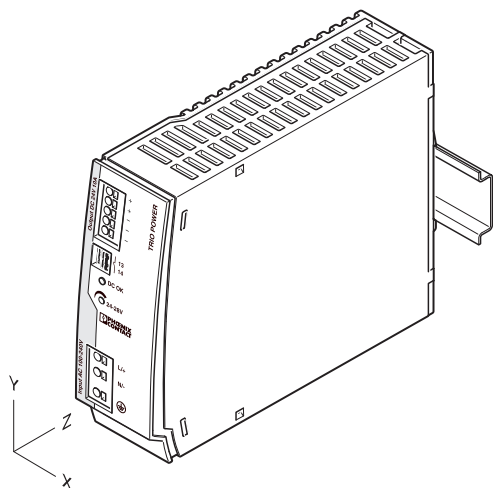

Rotated mounting position 90° X-axis

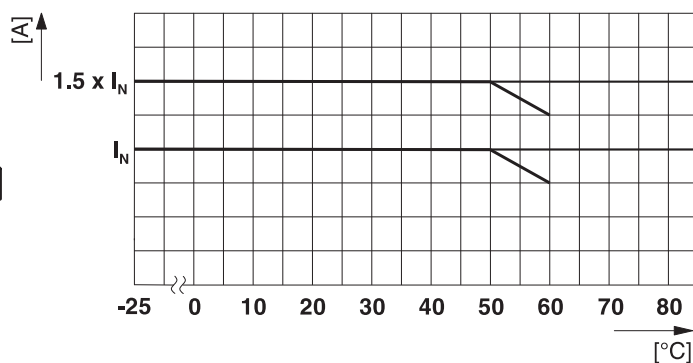
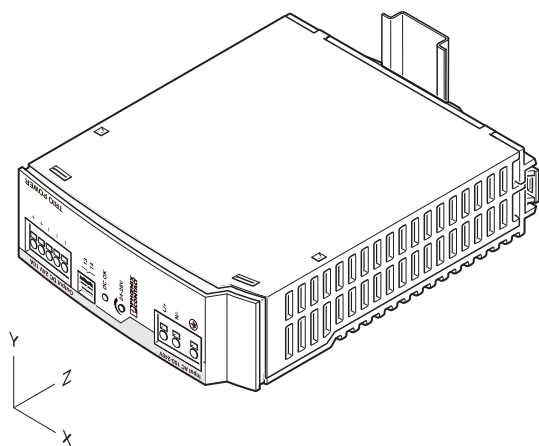

Rotated mounting position 180° X-axis

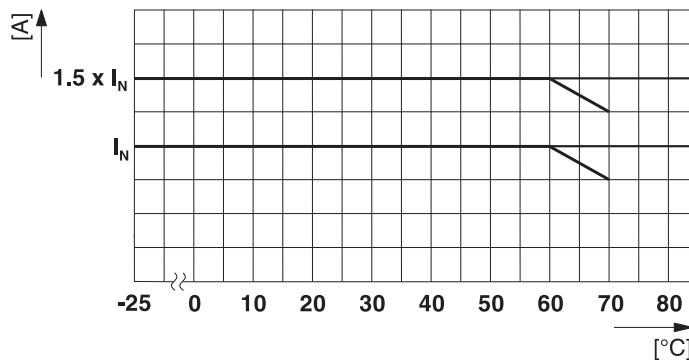
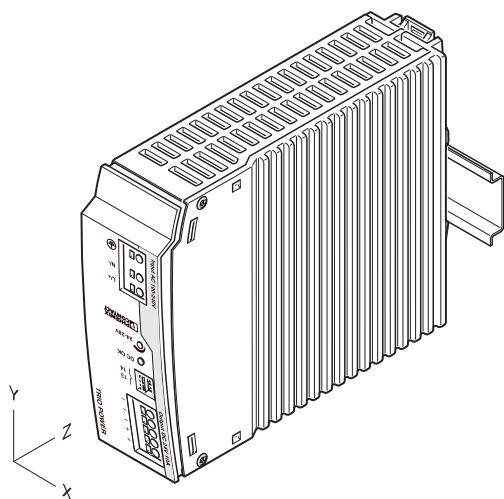

Rotated mounting position 270° X-axis

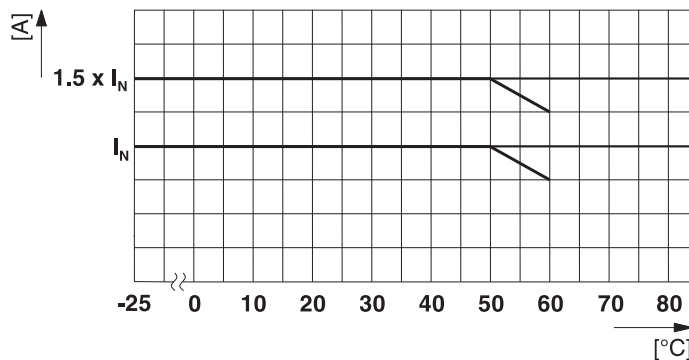
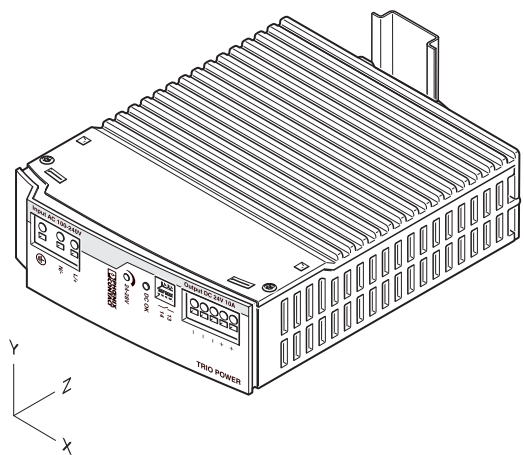

Rotated mounting position 90° Z-axis

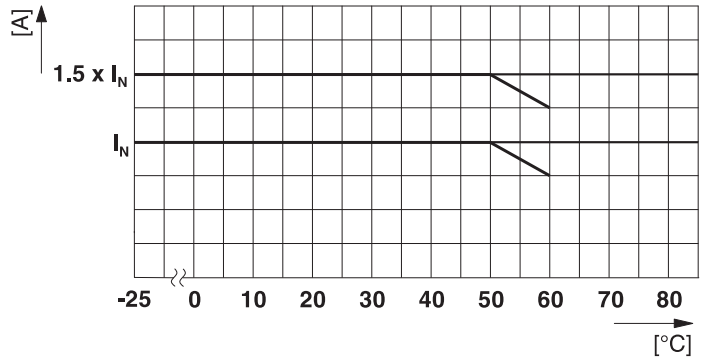
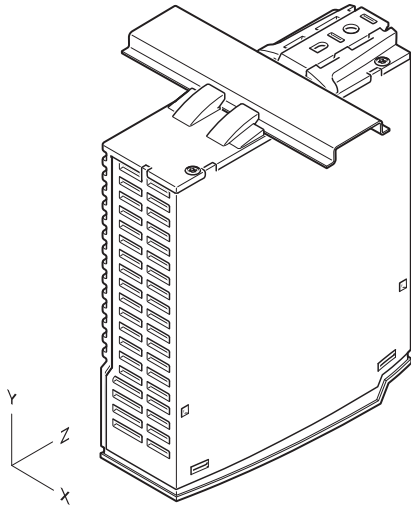

Rotated mounting position 270° Z-axis

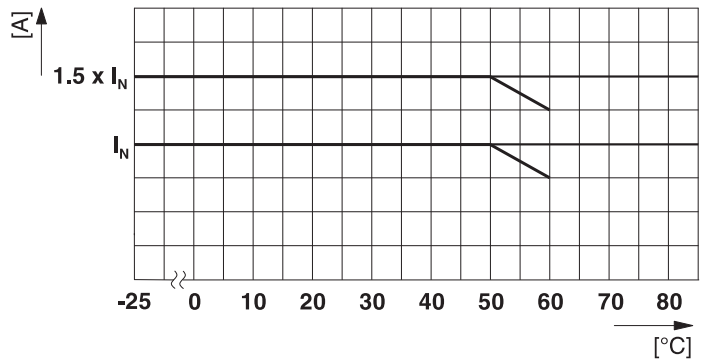
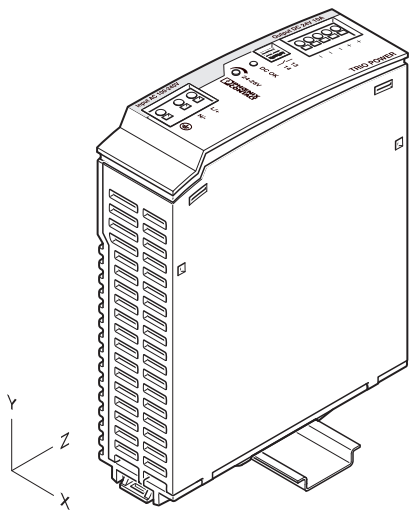

17 Operating modes

17.1 Series operation

Two power supplies can be switched in series, to double the output voltage. For connection in series, only power supplies of the same performance class should be used. An output voltage of, for example, 48 V DC can be provided, if two 24 V power supplies are connected in series.

Various voltage levels are made possible by varying the switching of the respective output voltage and the measurement reference point.

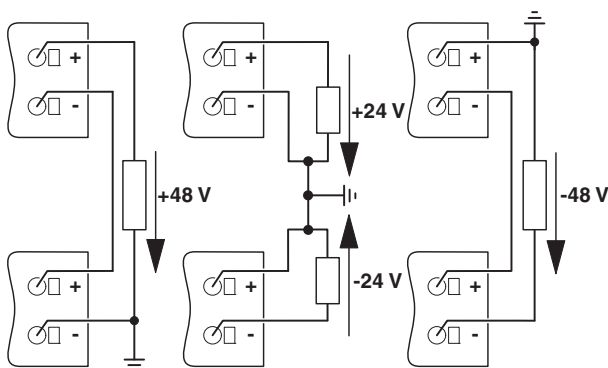

Figure 20 Wiring principle, voltage levels with two power supplies

17.2 Parallel operation

Devices of the same type can be connected in parallel to increase both redundancy and power. By default upon delivery, no further adjustments are required.

If the output voltage is adjusted, a uniform distribution of power is guaranteed by setting all parallel operated power supply units to exactly the same output voltage.

To ensure symmetrical current distribution we recommend that all cable connections from the power supply unit to the busbar are the same length and have the same cross section.

Depending on the system, for parallel connection of more than two power supplies a protective circuit should be installed at each individual device output (e.g., decoupling diode, DC fuse or circuit breaker). This prevents high return currents in the event of a secondary device fault.

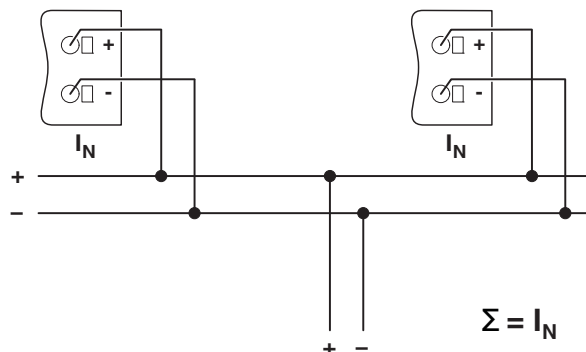

Figure 21 Schematic diagram in parallel operation

17.3 Redundant operation

Redundant circuits are suitable for supplying systems which place particularly high demands on operational reliability. If a fault occurs in the primary circuit of the first power supply unit, the second device automatically takes over the complete power supply without interruption, and vice versa. For this purpose, the power supply units to be connected in parallel must be large enough to ensure that the total current requirements of all loads can be fully met by one power supply unit. External decoupling diodes or ORING modules are required for 100% redundancy.

17.3.1 Decoupling with diode module

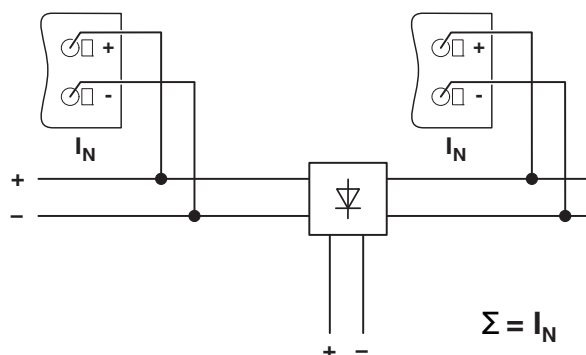

Figure 22 Schematic diagram, decoupling with diode module

17.3.2 Decoupling with ORING module

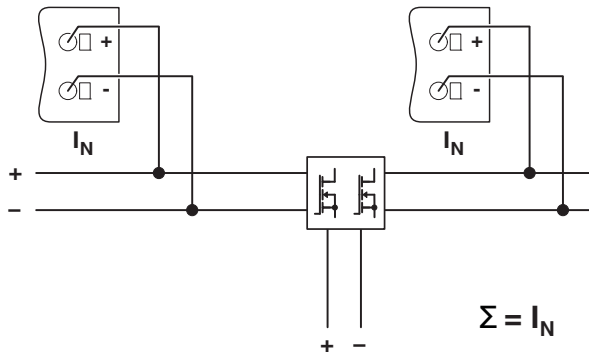

Figure 23 Schematic diagram, decoupling with ORING module

17.4 Increasing power

The output current can be increased to $n \times I_N$ in the case of n parallel connected devices. Parallel connection for increasing power is used when extending existing systems. A parallel connection is recommended if the power supply unit does not cover the current consumption of the most powerful load. Otherwise, the load should be distributed between individual devices that are independent from one another.

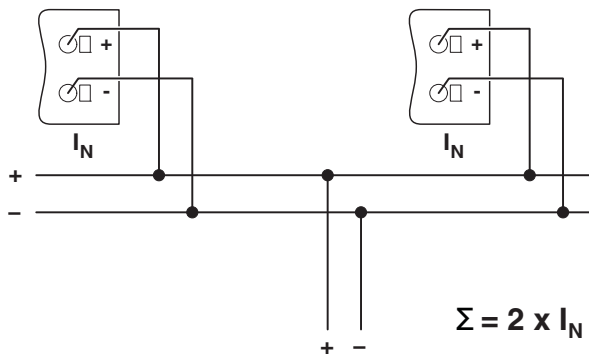

Figure 24 Schematic diagram of increased performance



SCATTERGOOD & JOHNSON LTD

ELECTRICAL ENGINEERING & FLUID CONTROL DISTRIBUTORS

Est.1899

At Scattergood & Johnson Ltd, we pride ourselves on being a technical distributor to specialist industries.

Working with a range of quality product suppliers across a number of specialist markets, we are not your average 'box shifter' - we are your technical and supply chain partner.

We fully support every product we sell - for free! Our internal team and external sales engineers can answer any product or application question, no matter the complexity.

Backing up this technical ability is a range of 50,000+ products available from stock for nationwide next day delivery (same day if required!), or you can collect what you need from any of our trade counters around the UK.

Select your specialist interest below to learn more about how we can help.



Online, In Branch and On the Road - Scattergood & Johnson Ltd, there when you need us.

www.scatts.co.uk