

UNO-DIODE/5-24DC/2X10/1X20

Redundancy module

Data sheet

106023_en_00

© PHOENIX CONTACT 2014-09-22



1 Description

Using the redundancy module, it is possible for two power supply units of the same type that are connected in parallel on the output side to increase performance or for redundancy to be isolated from one another..

The reliability of a power supply determines the availability of individual components in a system and whether complex systems can function safely.

Redundant circuits are intended to supply systems that set high demands on operational reliability. Long-term, permanent system availability is ensured by the redundant setup of the power supply.

The power supply of a system can be configured redundantly by switching at least two power supply units in parallel. Together, they then supply the connected devices.

The power supply units involved must be dimensioned to enable the total current requirements of all loads to be covered by one single power supply unit. In the event of an internal device fault or failure of the mains power supply on the primary side, the other device automatically takes over the entire power supply of the loads without interruption.

This means that operational reliability of the entire system can be effectively increased.

Features

- Decoupling power supply units switched in parallel
- Load currents up to 20 A are possible
- Flexible mounting by simply snapping onto the DIN rail



Make sure you always use the latest documentation.
It can be downloaded from the product at phoenixcontact.net/products.

2	Table of contents	
1	Description	1
2	Table of contents	2
3	Ordering data	3
4	Technical data	4
5	Intended use	7
6	Structure	7
	6.1 Device elements	7
	6.2 Block diagram	7
7	Assembly	8
	7.1 Unpacking	8
	7.2 Mounting the redundancy module	8
	7.3 Mounting on a DIN rail	10
	7.4 Normal mounting position	10
	7.5 Behavior in the case of alternative mounting positions	10
8	Install the redundancy module	14
	8.1 Safety regulations and installation notes	14
	8.2 Device connections	14
	8.3 Connecting cables	15
9	Redundancy module in operation	16
	9.1 Temperature response	16
10	Removal	16
	10.1 Uninstall the redundancy module	16
	10.2 Notes on disposal	16

3 Ordering data

Description	Type	Order No.	Pcs. / Pkt.
Redundancy module, 5 V ... 24 V DC, 2 x 10 A, 1 x 20 A.	UNO-DIODE/5-24DC/2X10/1X20	2905489	1

4 Technical data

Input data/output data

Nominal input/output voltage	5 V DC ... 24 V DC
DC input / output voltage range	4.5 V DC ... 30 V DC
Voltage drop, input/output	0.5 V
Nominal current	2x 10 A (-25°C ... 55°C) 1x 20 A (-25°C ... 55°C)
Transient surge protection	Varistor
Protection against polarity reversal	Yes , < 60 V
Derating	55 °C ... 70 °C (2.5%/K)
Power loss nominal load max.	5 W (I _{OUT} = 10 A)
Efficiency	> 97 %

General data

Insulation voltage input, output / housing	500 V
MTBF (IEC 61709, SN 29500)	> 60600000 h (40°C)
Mounting position	horizontal DIN rail NS 35, EN 60715
Housing material	Polycarbonate
Foot latch material	Plastic POM
Dimensions W / H / D	22.5 mm / 90 mm / 84 mm
Weight	0.2 kg

Security

Degree of protection	IP20
Protection class	III
SELV	IEC 60950-1 (SELV) and EN 60204 (PELV)

Input connection data

Connection method	Screw connection
Conductor cross section, solid	0.2 mm ² ... 2.5 mm ²
Conductor cross section, stranded	0.2 mm ² ... 2.5 mm ²
Conductor cross section AWG/kcmil	24 ... 14
Stripping length	8 mm
Screw thread	M3
Tightening torque	0.5 Nm ... 0.6 Nm

Output connection data

Connection method	Screw connection
Conductor cross section, solid	0.2 mm ² ... 2.5 mm ²
Conductor cross section, stranded	0.2 mm ² ... 2.5 mm ²
Conductor cross section AWG/kcmil	24
Stripping length	8 mm
Screw thread	M3
Tightening torque	0.5 Nm ... 0.6 Nm

Ambient conditions

Ambient temperature (operation)	-25 °C ... 70 °C (> 55 °C Derating: 2,5 %/K)
Ambient temperature (storage/transport)	-40 °C ... 85 °C
Max. permissible relative humidity (operation)	≤ 95 % (at 25 °C, non-condensing)

UNO-DIODE/5-24DC/2X10/1X20**Ambient conditions**

Vibration (operation)	< 15 Hz, amplitude ± 2.5 mm (according to IEC 60068-2-6) 15 Hz ... 150 Hz, 2.3g, 90 min.
Shock	30g in each direction, according to IEC 60068-2-27
Pollution degree in acc. with EN 50178	2
Climatic class	3K3 (in acc. with EN 60721)

Approvals

UL approvals	UL/C-UL listed UL 508 UL/C-UL Recognized UL 60950
--------------	--



Current approvals/permissions for the product can be found in the download area under phoenixcontact.net/products.

Conformance with EMC Directive 2004/108/EC**Noise immunity according to EN 61000-6-2**

	EN 61000-6-2 requirement	Tested
Electrostatic discharge EN 61000-4-2		
Housing contact discharge	4 kV (Test intensity 2)	4 kV (Test intensity 3)
Housing air discharge	8 kV (Test intensity 3)	8 kV (Test intensity 3)
Comments	Criterion B	Criterion B
Electromagnetic HF field EN 61000-4-3		
Frequency range	80 MHz ... 1 GHz	80 MHz ... 1 GHz
Test field strength	10 V/m	10 V/m
Frequency range	1.4 GHz ... 2 GHz	1 GHz ... 2 GHz
Test field strength	3 V/m	10 V/m
Frequency range	2 GHz ... 2.7 GHz	2 GHz ... 3 GHz
Test field strength	1 V/m	10 V/m
Comments	Criterion A	Criterion A
Fast transients (burst) EN 61000-4-4		
Input	2 kV (Test intensity 3 - asymmetrical)	2 kV (Test intensity 3 - asymmetrical)
Output	2 kV (Test intensity 3 - asymmetrical)	2 kV (Test intensity 3 - asymmetrical)
Comments	Criterion B	Criterion B
Surge current loads (surge) EN 61000-4-5		
Input	0.5 kV (Test intensity 2 - symmetrical) 0.5 kV (Test intensity 3 - asymmetrical)	1 kV (Test intensity 3 - symmetrical) 2 kV (Test intensity 4 - asymmetrical)
Output	0.5 kV (Test intensity 1 - symmetrical) 0.5 kV (Test intensity 1 - asymmetrical)	1 kV (Test intensity 2 - symmetrical) 2 kV (Test intensity 3 - asymmetrical)
Comments	Criterion B	Criterion B
Conducted interference EN 61000-4-6		
Input/Output/Signal	asymmetrical	asymmetrical
Frequency range	0.15 MHz ... 80 MHz	0.15 MHz ... 80 MHz
Voltage	10 V (Test intensity 3)	10 V (Test intensity 3)
Comments	Criterion A	Criterion A

Criterion A

Normal operating behavior within the specified limits.

Criterion B

Temporary impairment to operational behavior that is corrected by the device itself.

Emitted interference in acc. with EN 61000-6-3

Radio interference voltage in acc. with EN 55011

EN 55011 (EN 55022) Class B, area of application: Industry and residential

Emitted radio interference in acc. with EN 55011

EN 55011 (EN 55022) Class B, area of application: Industry and residential



All technical specifications are nominal values and refer to a room temperature of 25 °C and 70 % relative humidity at 100 m above sea level.

5 Intended use

This redundancy module features IP20 protection and is intended for installation in housing. It is suitable for use in industrial applications.

The technical specifications must be taken into consideration and observed.

6 Structure

6.1 Device elements

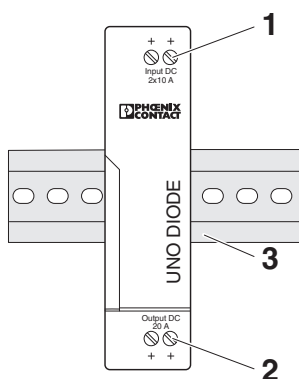

Figure 1 Device elements

1. DC input: Screw terminal blocks above
2. DC output: screw terminal blocks below
3. Universal snap-on foot: 35 mm DIN rail according to EN 60715

6.2 Block diagram

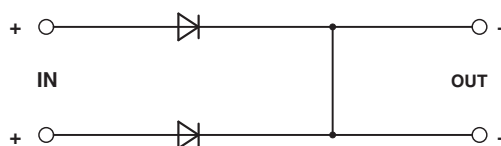



Figure 2 Block diagram

Element	Meaning
	Decoupling

7 Assembly

7.1 Unpacking

Before mounting the redundancy module, it must be checked for damage:

- Take the device out of its packaging.
- Check the device for any damage sustained during transport.
- Retain the package slip for future use.
- Dispose of packaging in an environmentally-friendly way.

7.2 Mounting the redundancy module



The redundancy module is intended for installation in a distributor box or control cabinet.



The redundancy module is designed for convection cooling. A minimum distance from other devices must be maintained in order to ensure convection cooling.

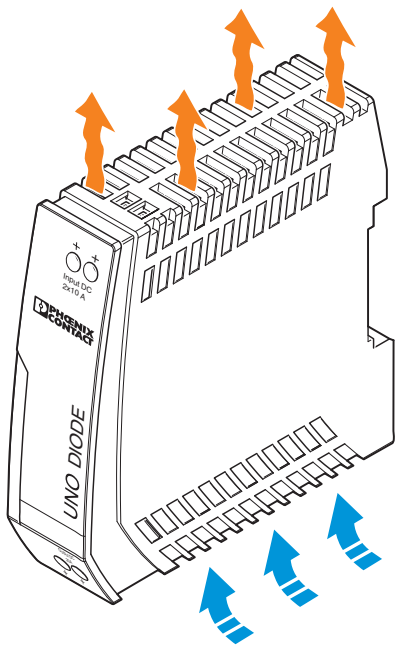

Figure 3 Convection

Prior to mounting the redundancy module:

- The minimum distance from other devices that must be observed in order to ensure convection cooling is: 30 mm vertically
- Lateral spacing of 5 mm, or 15 mm for active components, must be observed in order to ensure correct module function

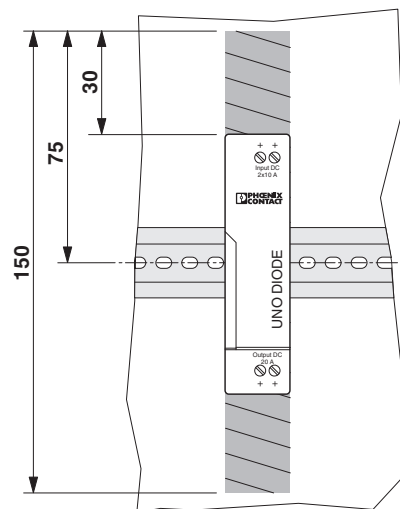

Figure 4 Locked areas

- The device dimensions

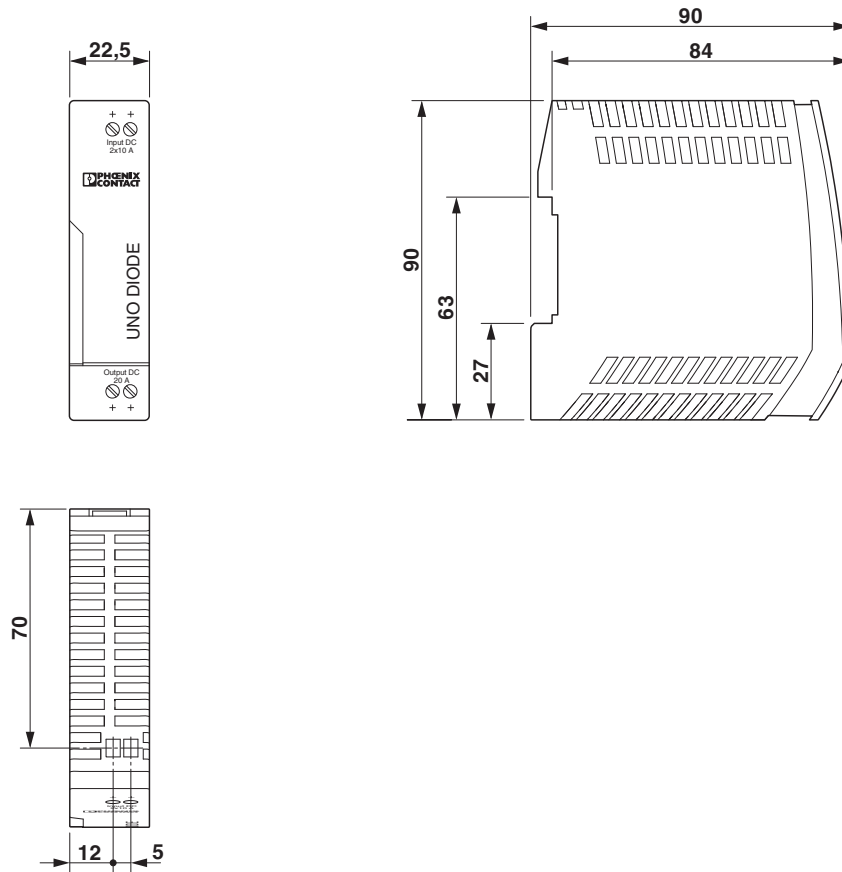

Figure 5 Device dimensions

7.3 Mounting on a DIN rail

The redundancy module can be installed on all 35 mm DIN rails according to EN 60175.

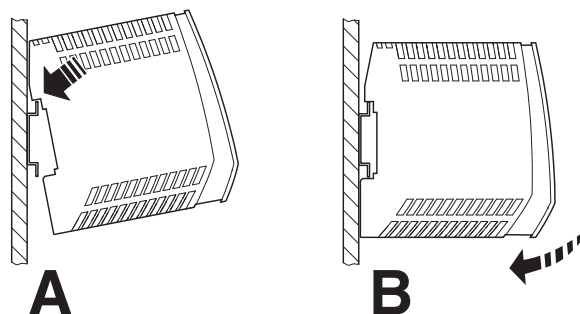

Figure 6 Mounting on a DIN rail

7.4 Normal mounting position

When installed, the input terminal blocks must be at the top and the output terminal blocks at the bottom.

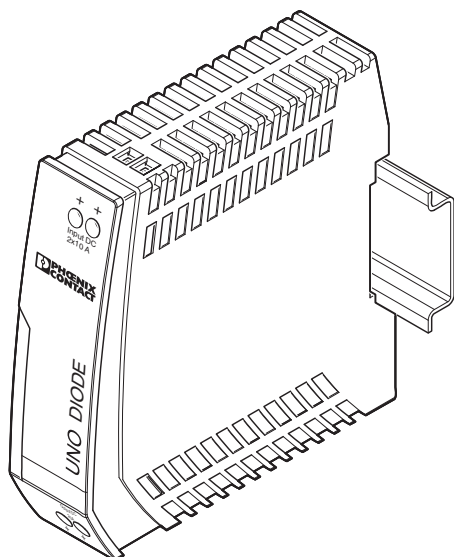

Figure 7 Normal mounting position

7.5 Behavior in the case of alternative mounting positions

For mounting positions that differ from the normal mounting position, the output power must be reduced (position-dependent derating).

The characteristic curve can be used to determine the maximum output power to be drawn for each ambient temperature for different mounting positions.

Normal mounting position

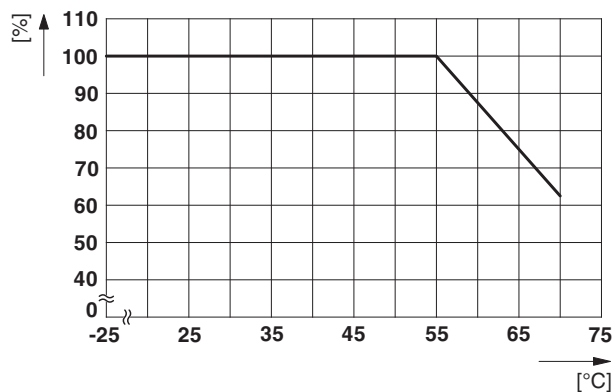
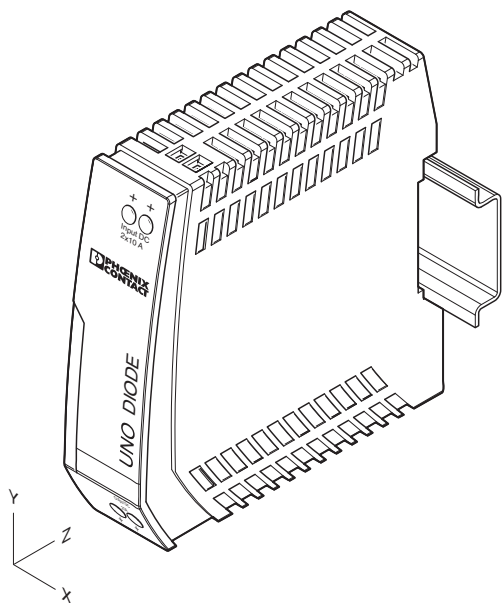

Figure 8 Normal mounting position

Rotated mounting position 90° X-axis

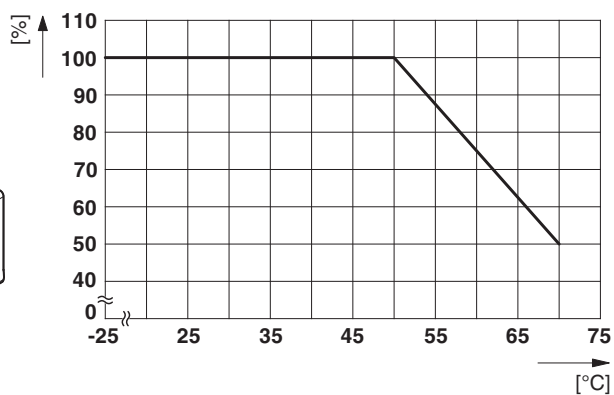
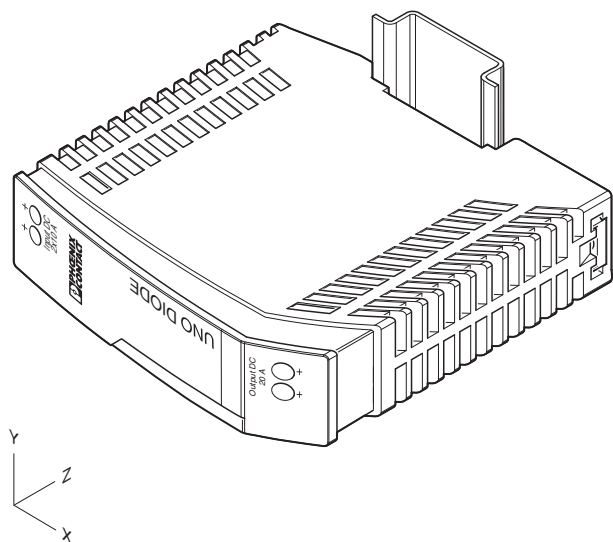

Figure 9 Rotated mounting position 90° X-axis

Rotated mounting position 180° X-axis

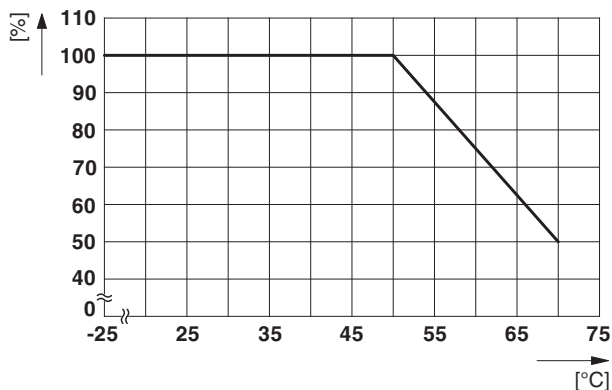
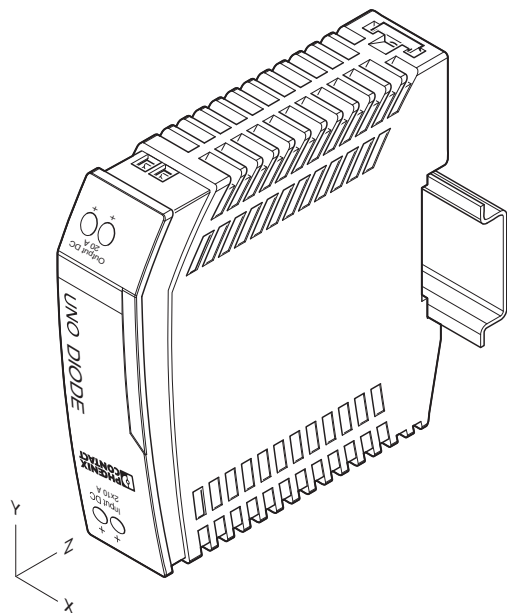

Figure 10 Rotated mounting position 180° X-axis

Rotated mounting position 270° X-axis

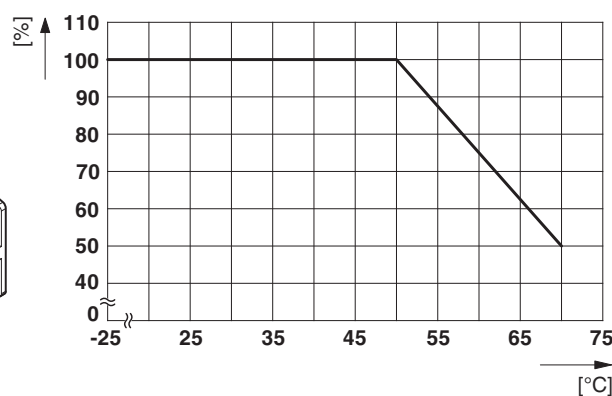
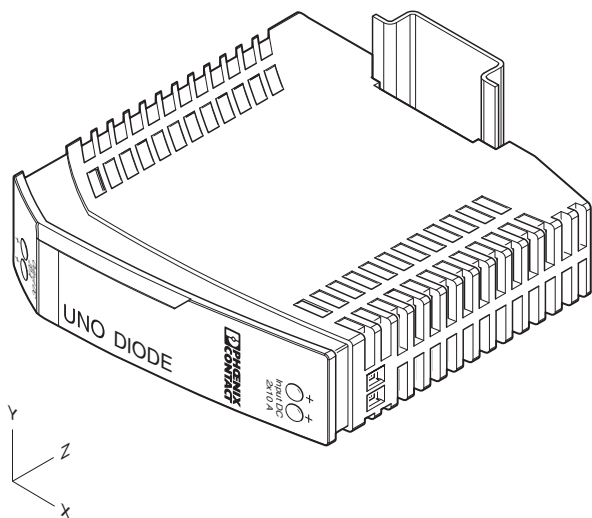

Figure 11 Rotated mounting position 270° X-axis

Rotated mounting position 90° Z-axis

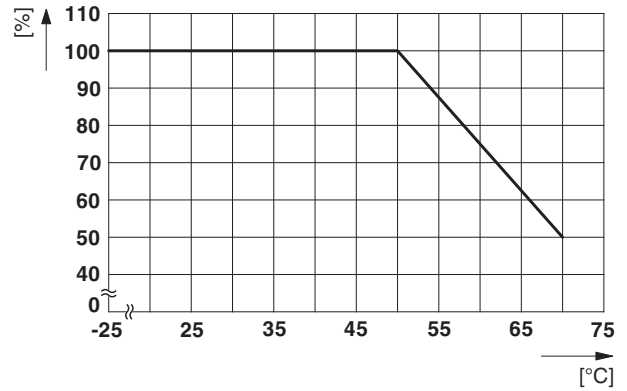
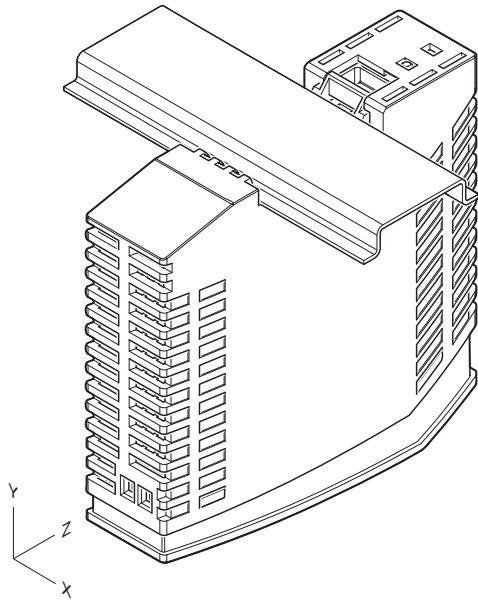

Figure 12 Rotated mounting position 90° Z-axis

Rotated mounting position 270° Z-axis

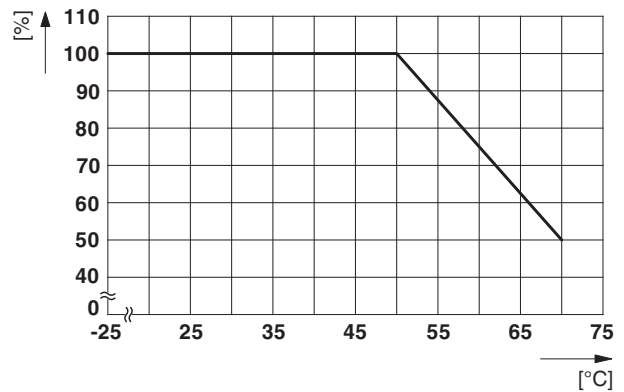
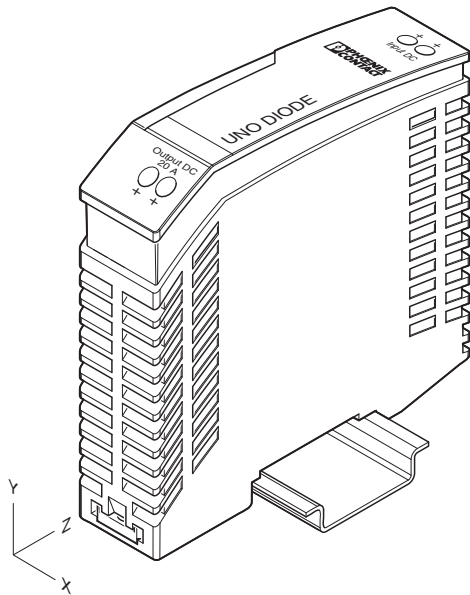

Figure 13 Rotated mounting position 270° Z-axis

8 Install the redundancy module

8.1 Safety regulations and installation notes



EXPLOSION HAZARD!

Only remove equipment when it is disconnected and not in the potentially explosive area.

DANGER

Never carry out work when the power is turned on.



CAUTION:

Before startup please ensure:

The connection must be carried out by a competent person and protection against electric shock guaranteed.

It must be possible to switch off power to device according to EN 60950.

All feed lines are sufficiently protected and dimensioned!

All output lines are dimensioned according to the maximum output current of the device or separately protected!

Sufficient convection must be guaranteed.



NOTE: Danger if used improperly

The redundancy module is a device installing into an enclosed space. Installation and start-up may only be carried out by qualified personnel. The relevant country-specific regulations must be observed.

8.2 Device connections

Screw connection for input DC

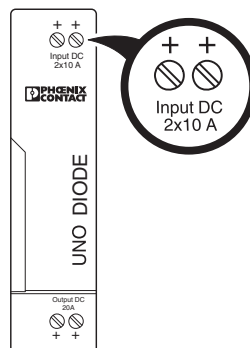

Figure 14 Screw connection for input DC

Screw connection for output DC

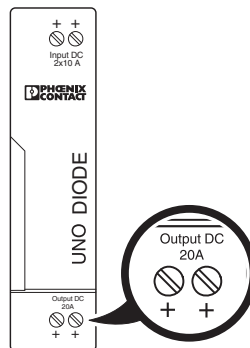

Figure 15 Screw connection for output DC

8.3 Connecting cables



Use copper cables with an operating temperature > 75°C (ambient temperature < 55°C) and > 90°C (ambient temperature < 75°C).



Use two cables of the same length and the same cross section to connect the redundancy module to the power supply.



The ambient temperature (operation) refers to UL 508 surrounding air temperature.



Use ferrules for flexible cables.

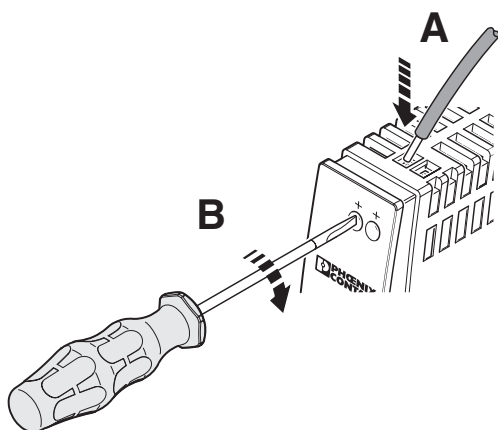

Figure 16 Connecting cables

1. Connect the supply lines to the input DC +/+ connection terminal blocks.
2. Connect the output cables to the output DC +/+ connection terminal blocks.

The redundancy module is operational as soon as the input terminal blocks are supplied with voltage.

Input

To decouple two parallel connected power supplies 1 and 2 with nominal currents of up to 10 A, one redundancy module is needed.

1. Connect one input of the redundancy module to one power supply in each case.

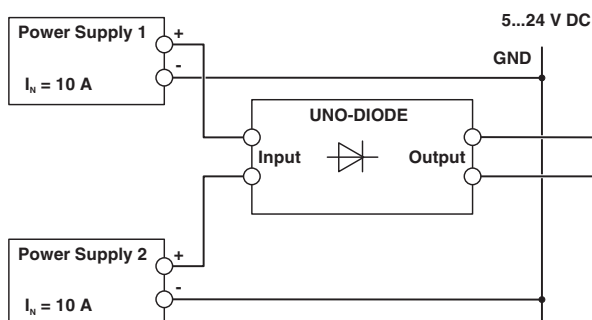

Figure 17 Decouple power supplies with nominal currents ≤ 10 A

One redundancy module per power supply is required to decouple power supplies with nominal currents greater than 10 A to 20 A.

1. For this purpose, connect the two inputs of one redundancy module to one power supply in each case.

This is necessary because the maximum current carrying capacity of 10 A per channel must not be exceeded.

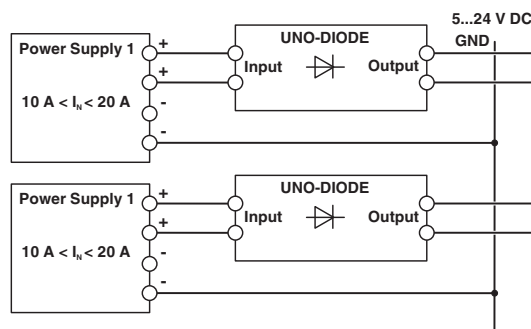

Figure 18 Decouple power supplies with nominal currents from 10 A to 20 A

Output

1. Wire the load with the plus terminals to the output of the redundancy module.



Close all unused clamping spaces.

9 Redundancy module in operation



WARNING: Risk of burns

Depending on the ambient temperature and the load, the housing can become very hot.



The redundancy module is maintenance-free. Repairs may only be carried out by the manufacturer.

The warranty no longer applies if the housing is opened.

9.1 Temperature response

In the horizontal mounting position, the redundancy module can carry current loads up to a maximum of 2 x 10 A or 1 x 20 A at an ambient temperature of up to 55°C. Depending on the ambient temperature, the permissible current carrying capacity is reduced in the case of a conductor cross section of 2.5 mm².

A maximum of 2 x 6.25 A or 1 x 12.5 A can be permanently carried at an ambient temperature of 70°C.

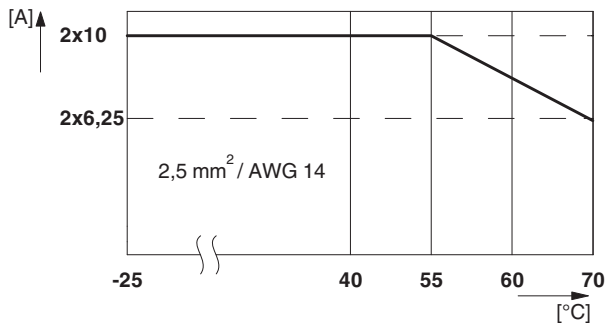

Figure 19 Temperature-dependent derating

10 Removal

10.1 Uninstall the redundancy module

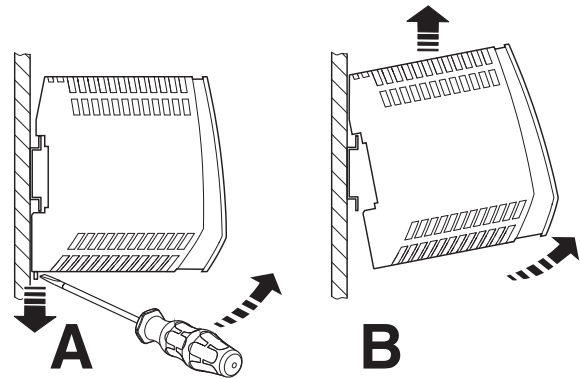

Figure 20 Removal

10.2 Notes on disposal



Do not dispose of the redundancy module with household waste. It should be disposed of in accordance with the currently applicable national regulations.



SCATTERGOOD & JOHNSON LTD

ELECTRICAL ENGINEERING & FLUID CONTROL DISTRIBUTORS

Est.1899

At Scattergood & Johnson Ltd, we pride ourselves on being a technical distributor to specialist industries.

Working with a range of quality product suppliers across a number of specialist markets, we are not your average 'box shifter' - we are your technical and supply chain partner.

We fully support every product we sell - for free! Our internal team and external sales engineers can answer any product or application question, no matter the complexity.

Backing up this technical ability is a range of 50,000+ products available from stock for nationwide next day delivery (same day if required!), or you can collect what you need from any of our trade counters around the UK.

Select your specialist interest below to learn more about how we can help.



Online, In Branch and On the Road - Scattergood & Johnson Ltd, there when you need us.

www.scatts.co.uk