

Electronic device circuit breaker - CBM E4 24DC/0.5-10A NO-R - 2905743

Please be informed that the data shown in this PDF Document is generated from our Online Catalog. Please find the complete data in the user's documentation. Our General Terms of Use for Downloads are valid (<http://phoenixcontact.com/download>)



Multi-channel, electronic device circuit breaker with active current limitation for protecting four loads at 24 V DC in the event of overload and short circuit. With nominal current assistant and electronic locking of the set nominal currents. For installation on DIN rails.

Your advantages

- For protection against voltage dips caused by overload and short circuit
- Precise nominal current levels of 0.5 to 10 A
- Integrated dynamic current limitation
- Electronic locking mechanism to increase system safety
- Early warning when exceeding 80% of the set nominal current per channel
- Supply up to 40 A possible
- Sophisticated remote signaling concept enables monitoring from any location
- Slim design



Key Commercial Data

Packing unit	1 pc
GTIN	 4 046356 992350
GTIN	4046356992350
Weight per Piece (excluding packing)	234.600 g
Custom tariff number	85362010
Country of origin	Germany

Technical data

Dimensions

Height	130 mm
Width	41 mm
Depth	121 mm (incl. DIN rail 7.5 mm)

Ambient conditions

Electronic device circuit breaker - CBM E4 24DC/0.5-10A NO-R - 2905743

Technical data

Ambient conditions

Ambient temperature (operation)	-25 °C ... 70 °C (Startup at -40 C type-tested)
	-25 °C ... 65 °C (for UL 2367)
Ambient temperature (storage/transport)	-40 °C ... 80 °C
Humidity test	240 h, 95 % RH, 40 °C
Altitude	≤ 6000 m (amsl (above mean sea level))
Shock (operation)	30g (IEC 60068-2-27, Test Ea)
Vibration (operation)	5 Hz ... 24.9 Hz (Amplitude ±1.6 mm; in accordance with IEC 60068-2-6, Test Fc)
	24.9 Hz ... 150 Hz (Acceleration 4g; in accordance with IEC 60068-2-6, Test Fc with additional resonance frequency testing in accordance with DNV GL)
Degree of protection	IP20

General

Flammability rating according to UL 94	V-0
Mounting type	DIN rail: 35 mm
Color	light grey RAL 7035
Number of positions	1
Protection class	III
Type	DIN rail module, one-piece

Electrical data

Fuse type	electronic
Rated surge voltage	0.5 kV
Operating voltage	18 V DC ... 30 V DC
Rated voltage	24 V DC
Rated current I_N	max. 40 A DC
	0.5 / 1 / 2 / 4 / 6 / 10 A DC (adjustable per output channel)
Measuring tolerance I	typ. 40 % (0.5 A ... 1 A)
	typ. 10 % (2 - 10 A)
Feedback resistance	max. 35 V DC
Fail-safe element	15 A DC (per output channel)
Active current limitation	typ. $2.0 \times I_N$ (0.5 - 1 A)
	typ. $1.5 \times I_N$ (2 - 10 A)
Efficiency	> 99 %
Closed circuit current I_0	typ. 42 mA
Power dissipation	1 W (No-load operation)
	9 W (Nominal operation)
Module initialization time	3.3 s
Waiting time after switch off of a channel	10 s (at overload / short circuit)
Temperature derating	40 A DC (at 70°C (65°C for UL 2367))

Electronic device circuit breaker - CBM E4 24DC/0.5-10A NO-R - 2905743

Technical data

Electrical data

Tripping method	E (electronic)
Required backup fuse	not required, integrated failsafe element
Dielectric strength	max. 30 V DC (Load circuit)
MTBF (IEC 61709, SN 29500)	2001962 h (at 25 °C)
	1292135 h (at 40 °C)
	653352 h (at 60 °C)
Shutdown time load circuit	0.02 s ($> 1.3 \times I_N$)
	30 s ($1.1 \dots 1.3 \times I_N$)
Undervoltage shutdown load circuit	≤ 17.8 V DC (active)
	≥ 19 V DC (inactive)
Surge voltage shutdown load circuit	≥ 30.5 V DC (active)
	≤ 29.5 V DC (inactive)
Max. capacitive load load circuit	75000 μ F (per channel at 24 V DC)
Output voltage status output	24 V DC
Output current status output	max. 20 mA (when $I > 80\%$ at at least one channel)
Input voltage reset input	7 V DC ... 30 V DC (Reset with falling edge)
Current consumption reset input	typ. 0.4 mA (at 24 V DC)
Pulse length reset input	≥ 50 ms (High signal)
	≥ 50 ms (Low signal)
Voltage reset input	< 5 V DC (Low signal)
	> 8 V DC (High signal)

Remote indication contact

Connection name	Remote indication circuit
Switching function	N/O contact
Stripping length	10 mm
Conductor cross section solid	0.2 mm ² ... 2.5 mm ²
Conductor cross section AWG	24 ... 12
Conductor cross section, flexible, with ferrule, with plastic sleeve	1.5 mm ² ... 0.25 mm ²
Conductor cross section flexible, with ferrule without plastic sleeve	0.25 mm ² ... 2.5 mm ²
DC operating voltage	0 V DC ... 30 V DC
DC operating current	1 mA DC ... 100 mA DC

Signaling

Channel LED off	off (Channel switched off)
Channel LED green	lit (Channel switched on)
	flashing (Channel switched on, programming mode active)
Channel LED yellow	lit (Channel switched on, channel load $> 80\%$)
Channel LED yellow-green	flashing (Channel switched on, nominal current assistant active)
Channel LED red	lit (Channel switched off, over- or undervoltage active)

Electronic device circuit breaker - CBM E4 24DC/0.5-10A NO-R - 2905743

Technical data

Signaling

	ON temporarily (Channel switched off, 10 s cool-down phase, overload or short-circuit release)
	flashing (Channel switched off, ready to be switched back on, overload or short-circuit release)
Channel LED red-yellow	flashing (Channel switched on, overload mode, capacity approximately 110 ... 130% , shutdown after 30 s)
Channel LED red-green	flashing (Channel switched off, programming mode active, current adjustment after overload or short-circuit release)
DC OK LED off	off (No supply voltage)
DC OK LED green	lit (Operating voltage in nominal range 18 ... 30 V)
DC OK LED yellow	lit (Undervoltage active, voltage ≤ 17.8 V, active channels switched off and channel LEDs are lit red)
	flashing (Undervoltage shutdown inactive, device was in undervoltage shutdown)
DC OK LED red	lit (Overvoltage shutdown active, voltage ≥ 30.5 V, channels switched off and channel LEDs are lit red)
	flashing (Overvoltage shutdown inactive, device was in overvoltage shutdown)

Connection data

Connection name	Main circuit IN+
Connection method	Push-in connection
Stripping length	18 mm
Conductor cross section solid	0.75 mm ² ... 16 mm ²
Conductor cross section AWG	20 ... 4
Conductor cross section, flexible, with ferrule, with plastic sleeve	0.75 mm ² ... 10 mm ²
Conductor cross section flexible, with ferrule without plastic sleeve	0.75 mm ² ... 16 mm ²
Connection name	Main circuit IN-
Connection method	Push-in connection
Stripping length	10 mm
Conductor cross section solid	0.2 mm ² ... 2.5 mm ²
Conductor cross section AWG	24 ... 12
Conductor cross section, flexible, with ferrule, with plastic sleeve	0.25 mm ² ... 1.5 mm ²
Conductor cross section flexible, with ferrule without plastic sleeve	0.25 mm ² ... 2.5 mm ²
Connection name	Main circuit OUT
Connection method	Push-in connection
Stripping length	10 mm
Conductor cross section solid	0.2 mm ² ... 2.5 mm ²
Conductor cross section AWG	24 ... 12
Conductor cross section, flexible, with ferrule, with plastic sleeve	0.25 mm ² ... 1.5 mm ²
Conductor cross section flexible, with ferrule without plastic sleeve	0.25 mm ² ... 2.5 mm ²

Standards and Regulations

<https://www.phoenixcontact.com/gb/products/2905743>

Electronic device circuit breaker - CBM E4 24DC/0.5-10A NO-R - 2905743

Technical data

Standards and Regulations

Standards/specifications	EN 61000-6-2
	EN 61000-6-3
	EN 60068-2-6
	EN 60068-2-11
	EN 60068-2-78

Environmental Product Compliance

REACH SVHC	Lead 7439-92-1
China RoHS	Environmentally friendly use period: unlimited = EFUP-e
	No hazardous substances above threshold values

Drawings

Electronic device circuit breaker - CBM E4 24DC/0.5-10A NO-R - 2905743

Diagram

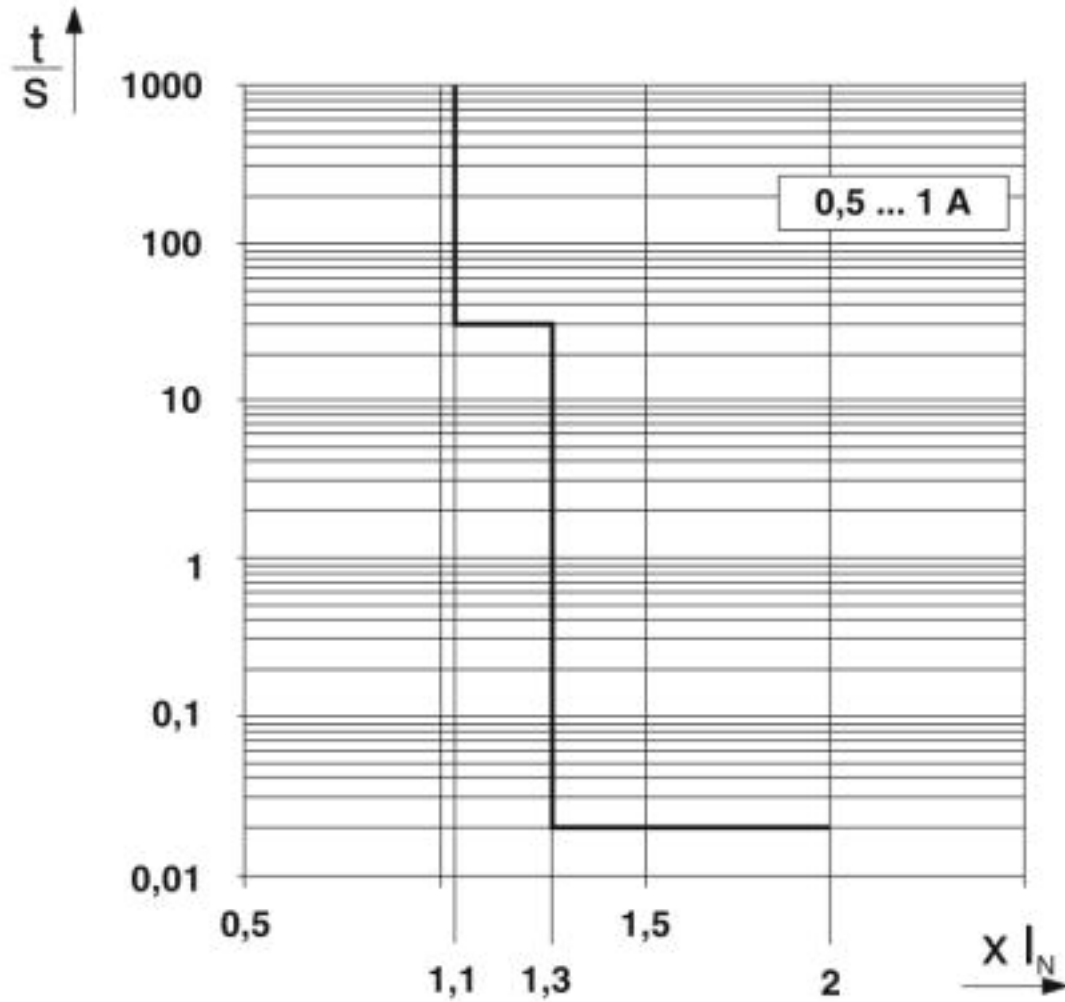

Trigger characteristic in the DC range

Electronic device circuit breaker - CBM E4 24DC/0.5-10A NO-R - 2905743

Diagram

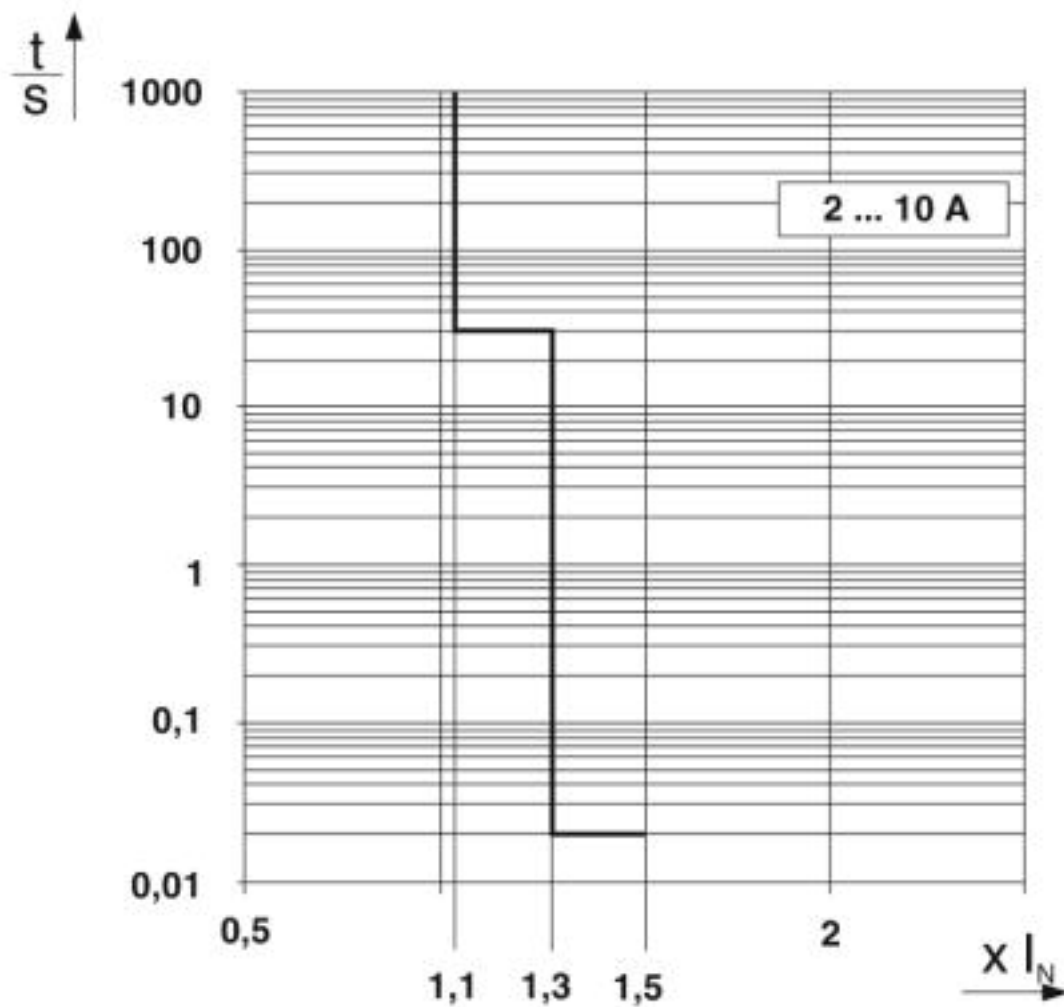

Trigger characteristic in the DC range

Electronic device circuit breaker - CBM E4 24DC/0.5-10A NO-R - 2905743

Dimensional drawing

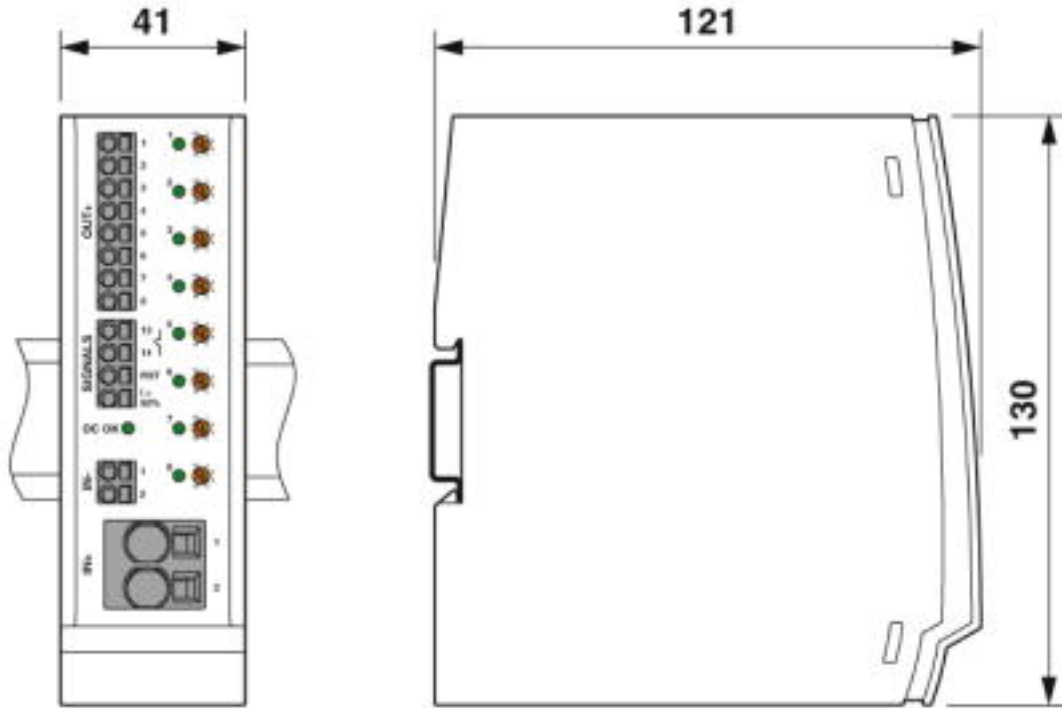

Electronic device circuit breaker - CBM E4 24DC/0.5-10A NO-R - 2905743

Application drawing

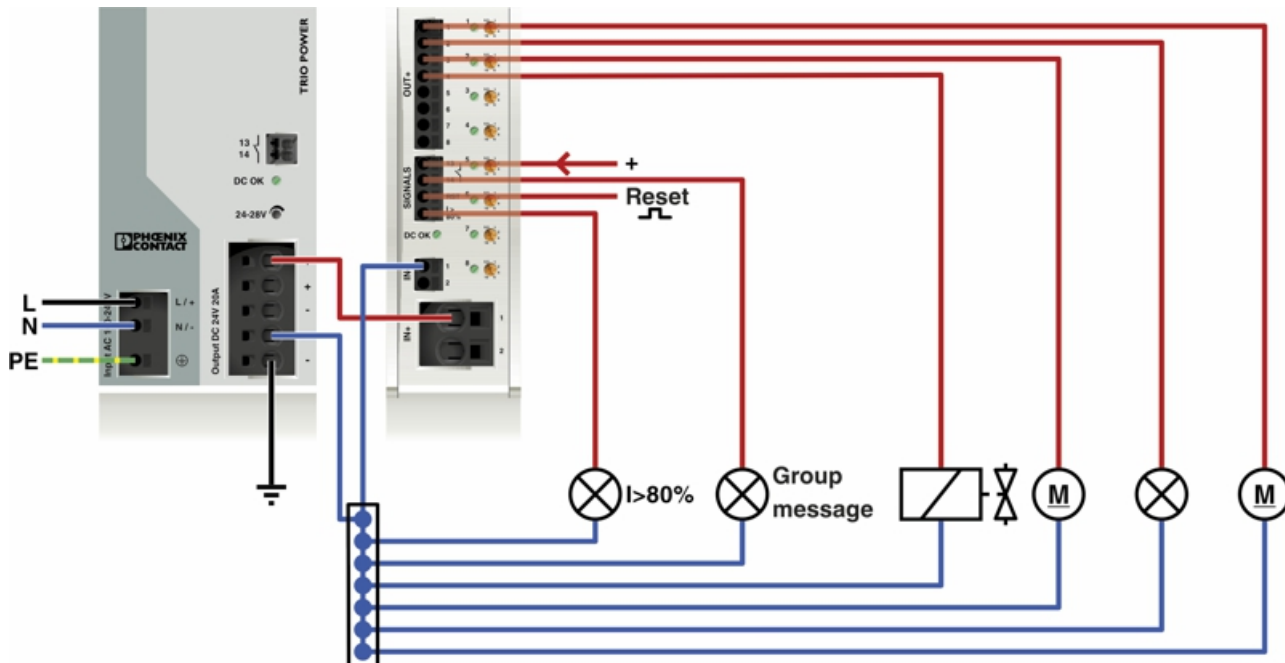

Classifications

eCl@ss

eCl@ss 10.0.1	27140401
eCl@ss 4.0	27141100
eCl@ss 4.1	27141100
eCl@ss 5.0	27141100
eCl@ss 5.1	27141100
eCl@ss 6.0	27141100
eCl@ss 7.0	27141116
eCl@ss 8.0	27141116
eCl@ss 9.0	27141116

<https://www.phoenixcontact.com/gb/products/2905743>



Electronic device circuit breaker - CBM E4 24DC/0.5-10A NO-R - 2905743

Classifications

ETIM

ETIM 5.0	EC000899
ETIM 6.0	EC000899
ETIM 7.0	EC000899

UNSPSC

UNSPSC 13.2	39121410
-------------	----------

Approvals

Approvals





Approvals

DNV GL / UL Listed / UL Recognized / cUL Listed / EAC / cULus Listed

Ex Approvals

UL Recognized / UL Listed / cUL Listed / cULus Listed

Approval details

DNV GL		https://approvalfinder.dnvgl.com/	TAA00000U2
UL Listed		http://database.ul.com/cgi-bin/XYV/template/LISEXT/1FRAME/index.htm	FILE E 123528
UL Recognized		http://database.ul.com/cgi-bin/XYV/template/LISEXT/1FRAME/index.htm	FILE E 317172
cUL Listed		http://database.ul.com/cgi-bin/XYV/template/LISEXT/1FRAME/index.htm	FILE E 123528
EAC			RU C- DE.A*30.B01561

<https://www.phoenixcontact.com/gb/products/2905743>



Electronic device circuit breaker - CBM E4 24DC/0.5-10A NO-R - 2905743

Approvals

cULus Listed



Phoenix Contact 2019 © - all rights reserved
<http://www.phoenixcontact.com>



SCATTERGOOD & JOHNSON LTD

ELECTRICAL ENGINEERING & FLUID CONTROL DISTRIBUTORS

Est.1899

At Scattergood & Johnson Ltd, we pride ourselves on being a technical distributor to specialist industries.

Working with a range of quality product suppliers across a number of specialist markets, we are not your average 'box shifter' - we are your technical and supply chain partner.

We fully support every product we sell - for free! Our internal team and external sales engineers can answer any product or application question, no matter the complexity.

Backing up this technical ability is a range of 50,000+ products available from stock for nationwide next day delivery (same day if required!), or you can collect what you need from any of our trade counters around the UK.

Select your specialist interest below to learn more about how we can help.

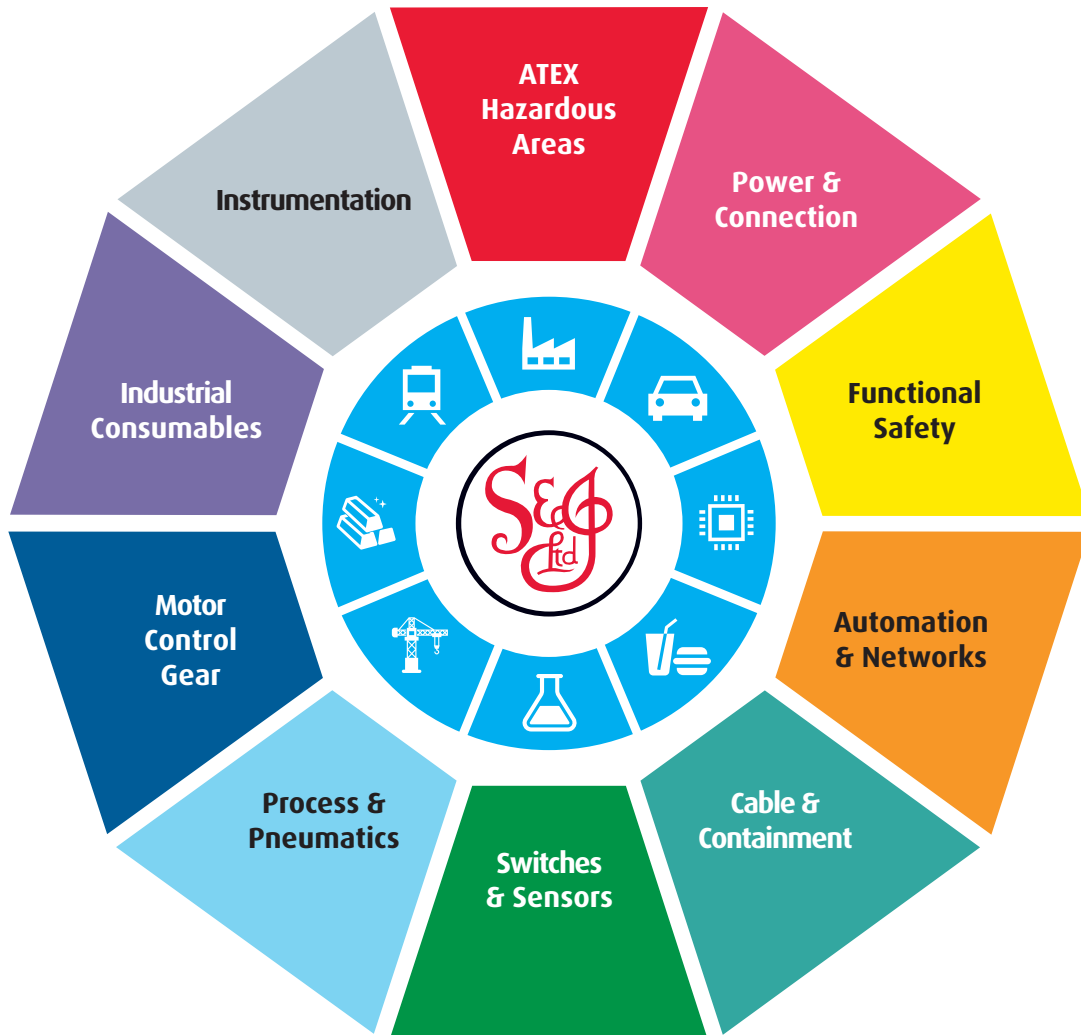

Online, In Branch and On the Road - Scattergood & Johnson Ltd, there when you need us.

www.scatts.co.uk