

## Power Supply, Primary Switch Mode, Narrow Design MINI-PS-100-240AC/24DC/4

### MINI POWER provides:

- **Extra narrow** widths of 22.5, 45, and 67.5 mm (0.886, 1.772, and 2.657 in.)
- **Global use** due to a wide range input
- **A high level of operational safety** in complex global networks
- **Reliable startup** of heavy loads due to POWER BOOST

The reliability of a power supply determines the availability of individual components in a system and whether complex systems can function safely.

The globalization of markets increases the demands placed on the power supply. A wide range input and a high level of availability are required. These requirements are met by MINI POWER.

### 1. Short Description

MINI POWER is the extra narrow power supply, which is available in widths of 22.5, 45, and 67.5 mm (0.886, 1.772, and 2.657 in.).

In addition to a 24 V version with output currents of 1 A, 2 A, and 4 A, special voltages are also available with 5 V/3 A, +/-15 V/1 A, and 10 - 15 V/2 A.

Reliable startup of heavy loads is ensured by a power reserve of up to 100% - the POWER BOOST.

The high level of operational safety is also ensured in complex global networks. MINI POWER also operates in applications where static voltage dips, transient power supply failures or phase failure are common.

Large capacitors ensure mains buffering of more than 20 ms at full load.



### 2. Area of Application

MINI POWER can be used globally due to the consistent provision of a wide range input.

In this way, your entire system can be tested at any production location in the world and can be delivered to any location in the world without faulty switching of the input voltage. This reduces storage costs and logistical effort.

An international approval package including UL 60950 for IT equipment and UL 508 for industrial control equipment enables the device to be used globally.

Power Supply, Primary Switch Mode, Narrow Design – MINI-PS-100-240AC/24DC/4

3. Technical Data

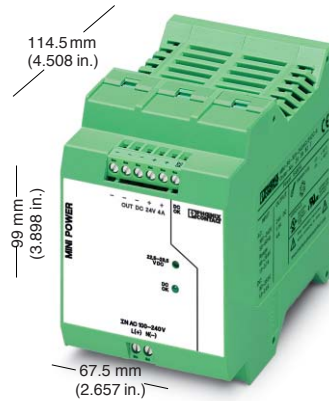
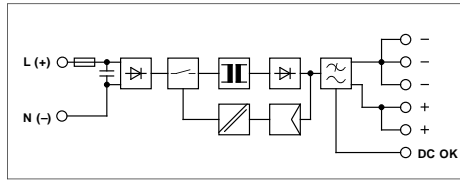

MINI-PS-100-240AC/24DC/4

7	solid	flexible			
		[mm <sup>2</sup> ]	AWG	[Nm]	[lb in.]
Input	0.2 - 2.5	0.2 - 2.5	25 - 14	0.5 - 0.6	4.4 - 5.3
Output	0.2 - 2.5	0.2 - 2.5	25 - 14	0.5 - 0.6	4.4 - 5.3
Signal	0.2 - 2.5	0.2 - 2.5	25 - 14	0.5 - 0.6	4.4 - 5.3

Description

**Power Supply**  
Primary switch mode, narrow design

Technical Data

Input Data ①

Nominal input voltage  
Input voltage range (current consumption)  
Frequency  
Current consumption (for nominal values)  
Inrush current limiting/ $I^2t$  (+25°C [+77°F])  
Mains buffering for a nominal load (typical)  
Switch-on time after applying the mains voltage  
Transient surge voltage protection  
Input fuse, internal  
Recommended fuse

Output Data ②

Nominal output voltage  $U_N$ /tolerance  
Setting range for the output voltage  
Output current during convection cooling and nominal values POWER BOOST  $I_{BOOST}$  (t = 2 min., typical)  
Nominal output current  $I_N$  -25°C to +40°C (-13°F to +104°F)  
Derating  
Short-circuit current limit  
Startup of capacitive loads  
System deviation on:  
Maximum power loss  
Level of efficiency (typical)  
Response time  $U_{OUT}$  (10% - 90%)  
Residual ripple/switching peaks (20 MHz)  
Can be connected in parallel  
Internal surge voltage protection  
Resistance to return supply

Signal Output Data

DC OK (active) ( $U_{out} > 0.9 \times U_N \hat{=}$  high signal)  
LED ( $U_{out} > 21.5$  V DC  $\hat{=}$  LED permanently on)

1 AC



Type

Order No.

Pcs. Pkt.

MINI-PS-100-240AC/24DC/4

29 38 83 7

1



100 - 240 V AC (wide range input)  
85 - 264 V AC 90 - 350 V DC  
45 - 65 Hz 0 Hz  
1.3 A (120 V AC)/0.8 A (230 V AC), approximately  
< 20 A/< 2.1 A<sup>2</sup>s, typical  
> 20 ms (120 V AC)/> 100 ms (230 V AC)  
< 0.4 s  
Varistor  
T3.15 AL 250 V (device protection)  
Line protection switch 6 A, 10 A, Characteristic B (EN 60 898)

24 V DC/±1%  
22.5 - 28.5 V DC

Up to 6 A ( $U_{out} = 24$  V DC)  
5A ( $U_{out} = 24$  V DC)  
4 A ( $U_{out} = 24$  V DC)  
From +60°C (+140°F), 2.5% per Kelvin  
9 A, approximately  
Unlimited  
< 1%, typical  
< 3%, typical  
< 0.1%, typical  
2.5 W/12 W  
> 88% (for 230 V AC and nominal values)  
0.3 ms  
< 100 mV<sub>pp</sub> (for nominal values)  
To increase redundancy and power  
Yes, limited to 35 V DC, approximately  
35 V DC

+24 V signal/20 mA, maximum  
Green LED

## Power Supply, Primary Switch Mode, Narrow Design – MINI-PS-100-240AC/24DC/4

General Data			
Insulation voltage:		Input/output	3 kV AC (type test)/3 kV AC (routine test)
Approval package			EN 60 204 (Surge Voltage Category III)
Electrical equipment of machines			EN 61 558-2-17
Safety transformers for switched-mode power supply units			EN 60950 / VDE 0805
Electrical safety (of IT equipment)			UL/C-UL Recognized UL 60 950  <sup>1)</sup>
Industrial control equipment			UL/C-UL Listed UL 508  <sup>1)</sup>
Equipping high voltage installations with electronic equipment			EN 50 178/VDE 0160
Safety extra-low voltage			PELV (EN 60 204)
			SELV (EN 60 950)
			VDE 0100-410
Safe isolation			
Protection against dangerous shock currents, basic requirements for safe isolation in electrical equipment			DIN VDE 0106-101
Limitation of harmonic line currents			According to EN 61000-3-2
Mounting position			On horizontal NS 35 DIN rail according to EN 50022
Can be mounted with spacing		- Vertical - Horizontal	≥ 5 cm (1.969 in.)
Degree of protection			0 cm
Class of protection			IP 20
MTBF			II, (in closed control cabinets)
Housing version			> 500 000 h according to IEC 1709 (SN 29 500)
Weight			Polyamide PA, color green
Dimensions (W x H x D)			0.4 kg, approximately
			67.5 x 99 x 114.5 mm (2.657 x 3.898 x 4.508 in.)
Climatic Data			
Ambient temperature		Operation Storage	-25°C to +70°C (-13°F to +158°F) (> +60°C [+140°F] derating)
Humidity			-40°C to +85°C (-40°F to +185°F)
Vibration			Up to 95% at +25°C (+77°F), no condensation
Shock			< 15 Hz, amplitude ±2.5 mm/15 Hz - 150 Hz, 2.3 g
Degree of pollution			30 g all space directions
Climatic category			2 (according to EN 50 178)
			3K3 (according to EN 60 721)



### Conforms to the EMC Directive 89/336/EEC and the Low Voltage Directive 73/23/EEC

#### EMC (Electromagnetic Compatibility) Noise Immunity According to EN 61000-6-2:

Test	Standard	Notes
Electrostatic discharge (ESD)	EN 61000-4-2 <sup>3)</sup>	Housing Contact discharge: Air discharge:
Electromagnetic HF field	EN 61000-4-3 <sup>2)</sup>	Housing Frequency: Field strength:
Fast transients (burst)	EN 61000-4-4 <sup>3)</sup>	Input: Output: Signal:
Surge current loads	EN 61000-4-5 <sup>3)</sup>	Input: Output:
Conducted interference	EN 61000-4-6 <sup>2)</sup>	I/O/S: Frequency: U <sub>0</sub> :
Voltage dips	EN 61000-4-11 <sup>3)</sup>	Input:
Simulation of radiophone	EN 50204	Frequency: Field strength:

#### Noise Emission According to EN 50081-2:

Radio interference	EN 55011
Radio interference	EN 55011

EN 55011 corresponds to CISPR11/EN 55022 corresponds to CISPR22

EN 61000 corresponds to IEC 1000

<sup>2)</sup>Criterion A: Normal operating characteristics within the specified limits.

<sup>3)</sup>Criterion B: Temporary adverse effects on the operating characteristics that the device corrects independently.

Requirements EN 61 000-6-2	MINI-PS-100-240AC/24DC/4
	> Level 3
4 kV	8 kV
8 kV	8 kV
80 - 1000 MHz	Level 3
10 V/m	80 - 1000 MHz
2 kV	10 V/m
2 kV	4 kV (Level 4)
1 kV	2 kV (Level 3)
	1 kV (Level 2)
2 kV	4 kV (Level 4)
1 kV	2 kV (Level 4)
0.5 kV	0.5 kV (Level 1)
0.5 kV	0.5 kV (Level 1)
1 kV	0.5 kV (Level 1)
0.15 - 80 MHz	Level 3
10 V	0.15 - 80 MHz
	10 V
30% reduction of the input voltage for 0.5 periods	See input data: Mains buffering > 20 ms
Not required	900 MHz/1800 MHz
	20 V/m
Class A <sup>6)</sup>	EN 55011 (EN 55022) Class B <sup>7)</sup>
Class A <sup>6)</sup>	EN 55011 (EN 55022) Class B <sup>7)</sup>

<sup>4)</sup>symmetrical: Cable to cable

<sup>5)</sup>asymmetrical: Cable to ground

<sup>6)</sup>Class A: Industrial application

<sup>7)</sup>Class B: Industrial and domestic applications

## 4. Device View, Connections, and Control Elements

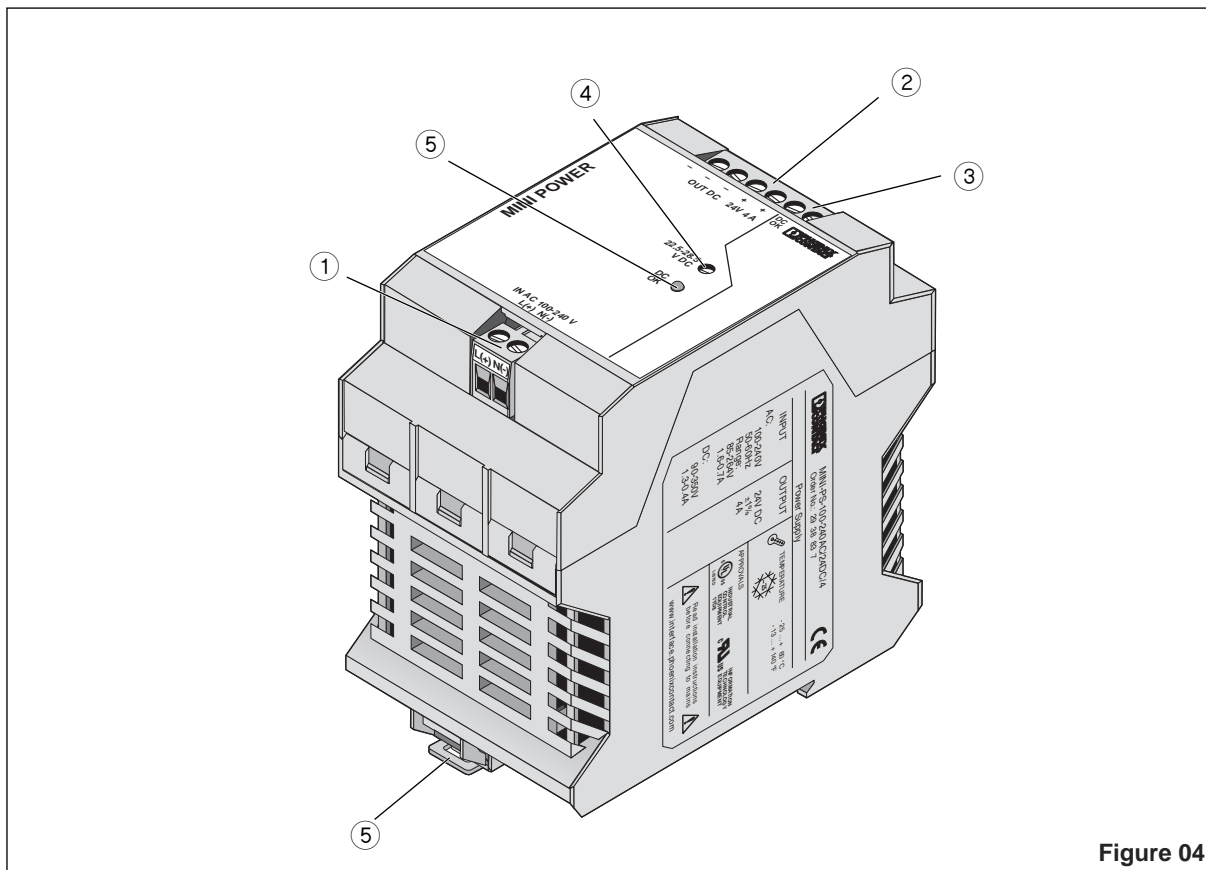

Figure 04

- ① **AC input:**  
Input voltage 85 - 264 V AC  
Frequency 45 - 65 Hz  
(0.2 mm<sup>2</sup> to 2.5 mm<sup>2</sup> solid)  
(0.2 mm<sup>2</sup> to 2.5 mm<sup>2</sup> flexible) (25 - 14 AWG)  
Internal fuse T3.15 AL 250 V  
Recommended fuse  
6 A or 10 A c.b./Characteristic B
- ② **DC output:**  
Output voltage 24 V DC (default),  
can be set from 22.5 - 28.5 V DC using  
a potentiometer ④ (0.2 mm<sup>2</sup> to 2.5 mm<sup>2</sup> solid)  
(0.2 mm<sup>2</sup> to 2.5 mm<sup>2</sup> flexible) (25 - 14 AWG)  
The device is idling-proof and short-circuit-proof.
- ③ **DC OK output active**
- ④ **Potentiometer 22.5 - 28.5 V DC**
- ⑤ **DC OK LED**
- ⑥ **Universal latching foot for EN DIN rails**

**Installation and startup** must only be carried out by qualified personnel. The relevant country-specific regulations (e.g., VDE, DIN) must also be observed.

Before startup it is particularly important to ensure that:

- The mains have been connected correctly and protection is provided against electric shock.
- The device can be switched off outside the power supply according to EN 60950 regulations (e.g., by the line protection on the primary side).
- All supply lines have sufficient fuse protection and are the correct size.
- All output cables are the correct size for the maximum device output current or have separate fuse protection.
- Sufficient convection is ensured.

MINI POWER is a built-in device. After installation the terminal area must be covered to provide sufficient protection against unauthorized access to live parts. This is ensured by installing the device in the control cabinet or distributor box.

**The device contains dangerous live components and high levels of stored energy.**

## 5. Safety and Warning Instructions

To ensure that the device can be operated safely and all functions can be used, please read these instructions carefully.



**Caution: Never carry out work when the power is turned on, this is highly dangerous.**

Power Supply, Primary Switch Mode, Narrow Design – MINI-PS-100-240AC/24DC/4

6. Installation

6.1. Mounting

The power supply can be snapped onto all DIN rails according to EN 50022-35. The device must be mounted horizontally (input terminal blocks facing downwards).

Installation Dimensions

 To ensure sufficient convection, we recommend a minimum spacing of 5 cm (1.969 in.) to other modules above and below the device.

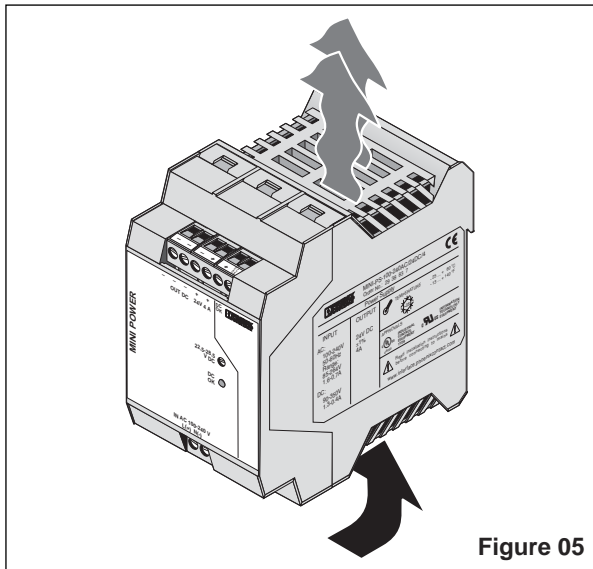

Figure 05

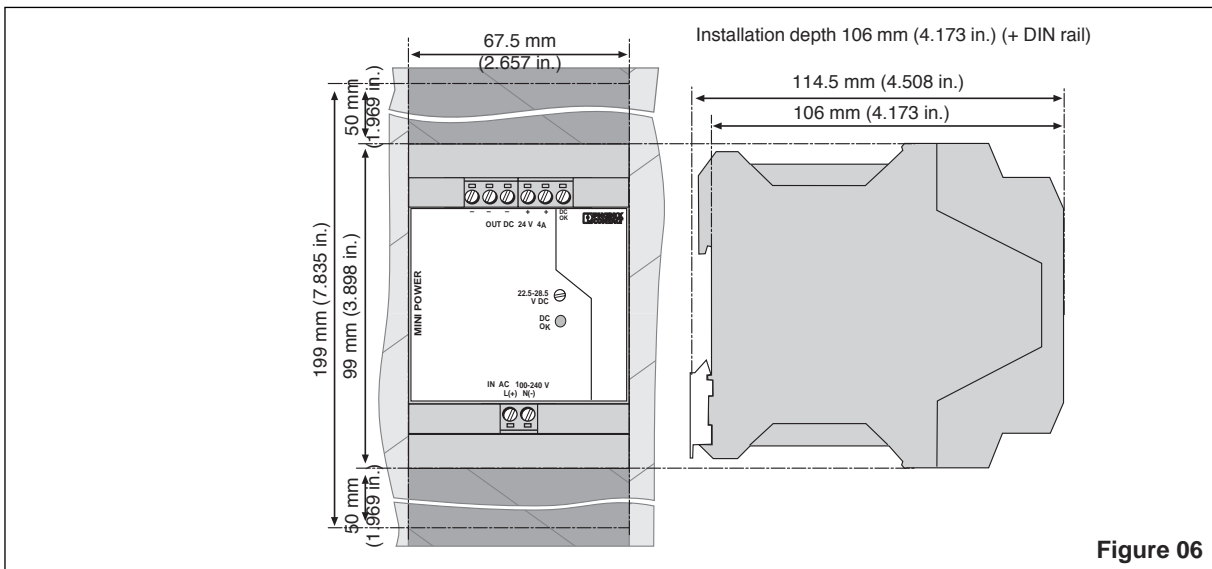

Figure 06

Mounting:

Place the module with the DIN rail guideway on the **top edge** of the DIN rail and then snap it **downwards**.

Removal:

Release the snap-on catch using a screwdriver and then detach the module from the **bottom edge** of the DIN rail.

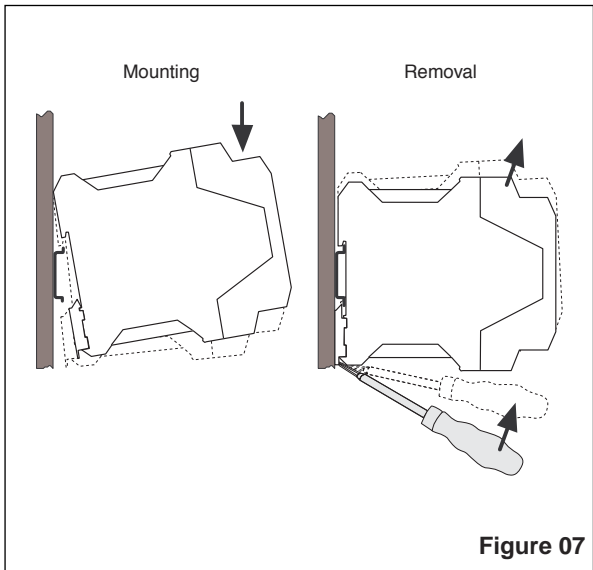

Figure 07

Power Supply, Primary Switch Mode, Narrow Design – MINI-PS-100-240AC/24DC/4

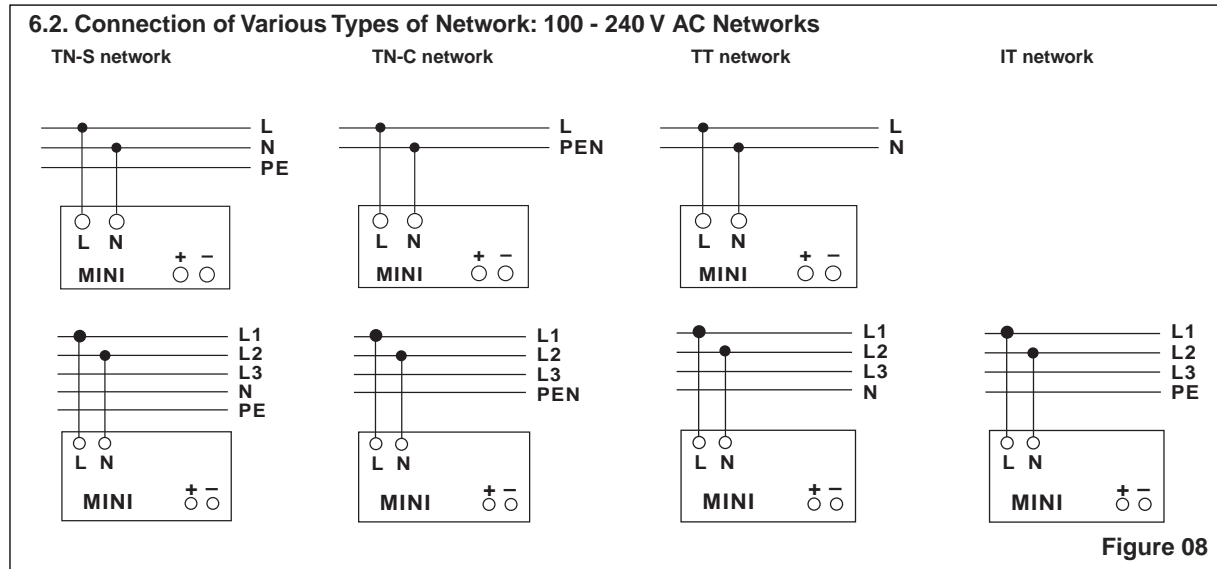

Figure 08

**Connection Cable:**

The device is equipped with COMBICON connectors. This reliable user-friendly connection method enables quick device connection and safe isolation of the electrical connection, if required. **Only operate connectors when the power is switched off.**

The following cable cross sections can be connected:

	Solid [mm <sup>2</sup> ]	Flexible [mm <sup>2</sup> ]	AWG	Torque [Nm]	Torque [lb in.]
① Input:	0.2 - 2.5	0.2 - 2.5	25 - 14	0.5 - 0.6	4.4 - 5.3
② Output:	0.2 - 2.5	0.2 - 2.5	25 - 14	0.5 - 0.6	4.4 - 5.3
③ Signal:	0.2 - 2.5	0.2 - 2.5	25 - 14	0.5 - 0.6	4.4 - 5.3

**For reliable and safe-to-touch connection:** Strip 7 mm (0.28 in.) from the connector ends.

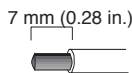

**6.3. Input (①, Figure 9)**

The 100 - 240 V AC connection is made using screw connections L and N. The device can be connected to single-phase AC networks or to two external conductors for three-phase networks (TN, TT or IT network according to VDE 0100 T300/IEC364-3) with nominal voltages of 100 - 240 V AC.

**Protecting the Primary Side**

The device must be installed according to the specifications of EN 60 950. It must be possible to switch off the device using a suitable disconnecting device outside the power supply.

Note that an all-pole disconnecting device must be provided for two-phase operation using two external conductors for a three-phase network.

For example, primary side line protection could be used.

Additional device protection is not required, as an internal fuse is present.

**Recommended Fuse:**

Circuit breaker 6 A or 10 A, Characteristic B (or equivalent).

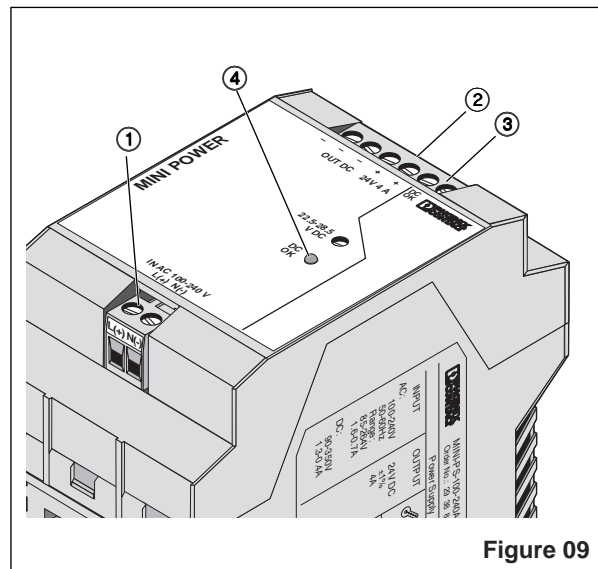

Figure 09

A suitable fuse must be fitted for DC applications.

**⚡ If the internal fuse is blown, this is most probably due to a device fault. In this case, the device should be checked in the factory.**

**Power Supply, Primary Switch Mode, Narrow Design – MINI-PS-100-240AC/24DC/4**

**6.4. Output (② , Figure 9)**

NEC Class 2 power supply when installed with a 4.2 amp maximum, UL listed fuse or circuit breaker in the output of the power supply. This procedure must be followed to meet NEC Class 2 requirements

**Protecting the Secondary Side:**

The device is electronic short-circuit-proof and idling-proof. In the event of an error, the output voltage is limited to a maximum of 35 V DC.

It should be ensured that all output cables are the correct size for the maximum output current or have separate fuse protection.

The secondary side cables should have large cross sections to keep voltage drops on the cables to a minimum.

**Active signal output (③ , Figure 10)**

The 24 V DC signal is between the "DC OK" and "-" connection terminal blocks and can be loaded with 20 mA maximum. This signal output indicates that the output voltage has fallen below 21.5 V DC when "active high" changes to "low".

The DC OK signal is isolated from the power output. This ensures that a separate supply does not enter from devices connected in parallel.

The 24 V DC signal can be connected directly to the logic input for evaluation.

**DC OK LED**

The green DC OK LED enables local function evaluation in the control cabinet.

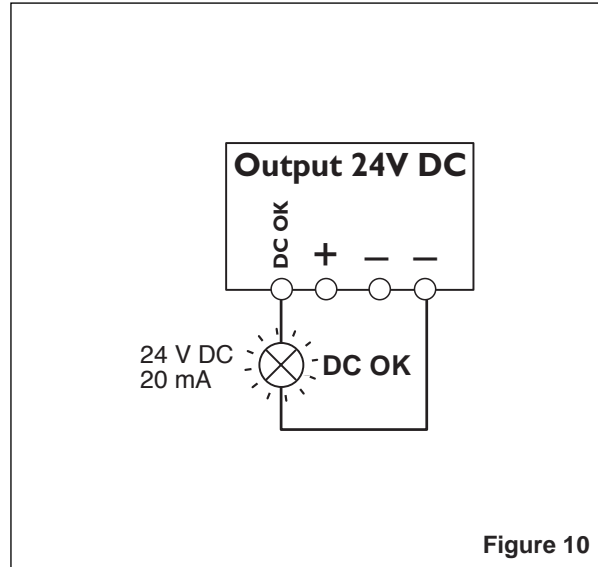

**Figure 10**

	Status 1	Status 2
<b>Green "DC OK" LED ⑤</b>	ON	OFF
<b>Active DC OK switching output</b>	U = +24 V (with reference to "-")	U = 0 V (with reference to "-")
<b>Meaning</b>	Normal operation of the power supply U <sub>OUT</sub> > 21.5 V	U <sub>OUT</sub> ≤ 21.5 V DC <ul style="list-style-type: none"> <li>• Secondary load short circuit or overload</li> <li>• No mains voltage or device fault</li> </ul>

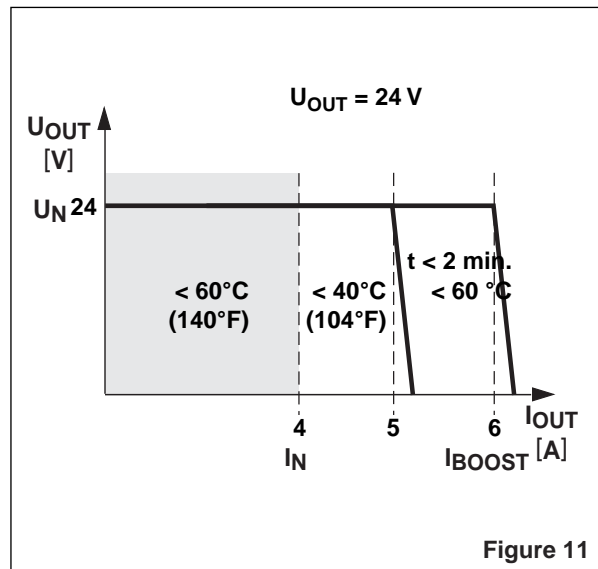

**Figure 11**

**7. Installation**

**7.1. Output Characteristic Curve**

The device can supply a nominal output current of 4 A up to an ambient temperature of 60°C (140°F). With an ambient temperature of up to 40°C (104°F) the device continuously supplies an output current of 5 A. At temperatures up to 60°C (140°F), the POWER BOOST provides a short-term output current of 6 A for a few minutes.

With high loads, the working point demonstrates the U/I characteristic curve shown in Figure 11.

On an overload or short circuit, the entire output current I<sub>BOOST</sub> is provided permanently at a reduced output voltage.

Once the overload or short circuit has been removed, the entire set secondary voltage is available again.

The U/I characteristic curve ensures that both heavy capacitive loads and devices with DC/DC converters can be supplied by MINI POWER in the input circuit without any problems.

Connected fuses are reliably tripped. The selectivity in your system configuration is ensured at all times.

**Power Supply, Primary Switch Mode, Narrow Design – MINI-PS-100-240AC/24DC/4**

**7.2. Temperature Response**

The device can supply a nominal output current of 4 A up to an ambient temperature of 60°C (140°F). With an ambient temperature of up to 40°C (104°F) the device continuously supplies an output current of 5 A. At temperatures up to 60°C (140°F), the POWER BOOST provides a short-term output current of 6 A for a few minutes.

The output power must be decreased by 2.5% per Kelvin temperature increase for ambient temperatures above +60°C (+140°F). At ambient temperatures above +70°C (+158°F) or in the event of a thermal overload, the device reduces the output power to protect itself and returns to normal operation once it has cooled down.

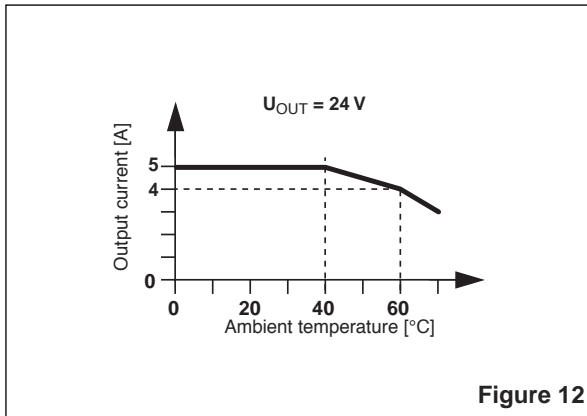

Figure 12

**7.3. Parallel Operation**

Devices of the same type can be connected in parallel to increase both redundancy and power. The default setting does not have to be adjusted.

If the output voltage is adjusted, an even current distribution can be ensured by precisely setting all power supplies that are operated in parallel to the same output voltage.

To ensure symmetrical current distribution we recommend that all cable connections from the power supply to the DIN rail are the same length and have the same cross section.

Depending on the system, for parallel connection of more than two power supplies a protective circuit should be installed at each individual device output (e.g., decoupling diode or DC fuse). This means that in the event of a secondary device fault high return currents are avoided.

**7.4. Redundancy Operation**

Redundant connections are designed for supplying systems, which place particularly high requirements on operational safety. If a fault occurs in the primary circuit of device 1, device 2 automatically takes over the complete power supply without interruption and vice versa.

For this purpose, the power supplies to be connected in parallel must be large enough that the total current requirements of all loads can be fully met by one power supply. External decoupling diodes are required for 100% redundancy.

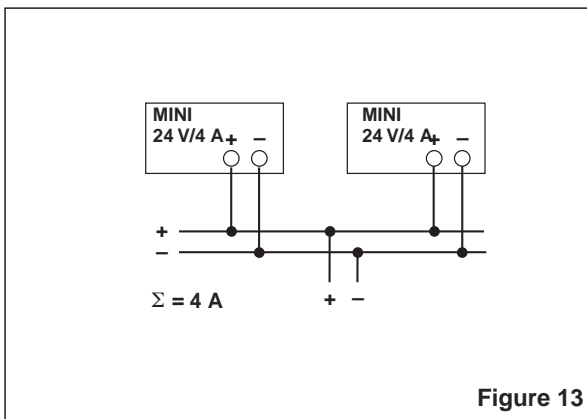

Figure 13

**7.5. Power Increase**

The output current can be increased to  $n \times I_N$  where  $n$  is the number of devices connected in parallel.

The parallel connection for power increase can be used to extend existing systems. A parallel connection is recommended if the power supply does not cover the current consumption of the most powerful load. Otherwise, the loads should be divided over independent individual devices.

A maximum of five devices can be connected in parallel.

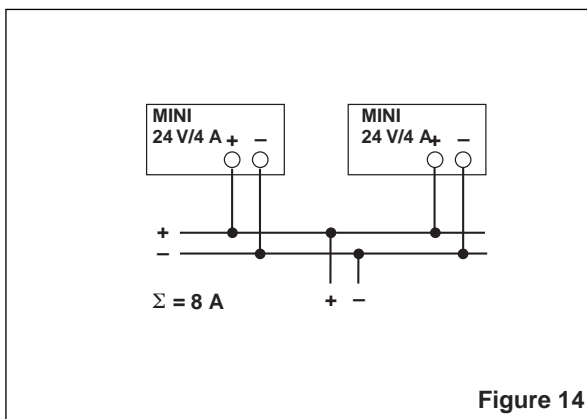

Figure 14

© PHOENIX CONTACT 03/15/05 TNR: 5107911-02 http://www.phoenixcontact.com



# SCATTERGOOD & JOHNSON LTD

ELECTRICAL ENGINEERING & FLUID CONTROL DISTRIBUTORS

Est.1899

At Scattergood & Johnson Ltd, we pride ourselves on being a technical distributor to specialist industries.

Working with a range of quality product suppliers across a number of specialist markets, we are not your average 'box shifter' - we are your technical and supply chain partner.

We fully support every product we sell - for free! Our internal team and external sales engineers can answer any product or application question, no matter the complexity.

Backing up this technical ability is a range of 50,000+ products available from stock for nationwide next day delivery (same day if required!), or you can collect what you need from any of our trade counters around the UK.

Select your specialist interest below to learn more about how we can help.



Online, In Branch and On the Road - Scattergood & Johnson Ltd, there when you need us.

# [www.scatts.co.uk](http://www.scatts.co.uk)