

## Power Supply, Primary Switch Mode, Flat Design STEP-PS-100-240AC/...DC/...

### STEP POWER provides:

- **Standardized installation dimensions** for small distribution boards
- **Global use** due to a wide range input
- **A high level of operational safety** in complex global networks
- **Reliable startup** of heavy loads due to power reserve

The reliability of a power supply determines the availability of individual components in a system and whether complex systems can function safely.

The globalization of markets increases the demands placed on the power supply. A wide range input and a high level of availability are required. These requirements are met by STEP POWER.

### 1. Brief Description

STEP POWER is an intelligent solution in an extra flat design. With a depth of 58 mm (2.283 in.), the power supply fits in all small distribution boards as well as small operating panels. The complete voltage range 5 V/4 A, 12 V/3 A, 15 V/2.4 A, 24 V/1.5 A, and 48 V/0.75 A is covered with 5 devices. What is particularly intelligent is the powerful power reserve of up to 100%, which meets the requirements of every load.

The high level of operational safety is also ensured in complex global networks.

STEP POWER also operates in applications where static voltage dips, transient power supply failures or phase failure are common.

Large capacitors ensure mains buffering of more than 20 ms at full load.



### 2. Area of Application

STEP POWER can be used globally due to the consistent provision of a wide range input.

In this way, your entire system can be tested at any production location in the world and can be delivered to any location in the world without faulty switching of the input voltage. This reduces storage costs and logistical effort.

An international approval package including UL 60950 for IT equipment and UL 508 for industrial control equipment enables the device to be used globally.

Power Supply, Primary Switch Mode, Flat Design – STEP-PS-100-240AC/...DC/...

3. Technical Data

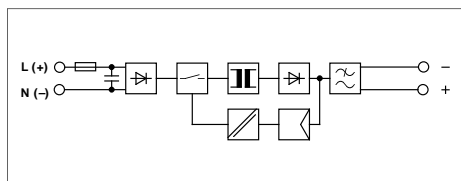

STEP-PS-100-240AC/...DC/...

6.5 mm (0.26 in.)	solid	flexible		torque
	[mm <sup>2</sup> ]	AWG		[Nm]
Input	0.2 - 2.5	0.2 - 2.5	24 - 14	0.5 - 0.6
Output	0.2 - 2.5	0.2 - 2.5	24 - 14	0.5 - 0.6

1 AC



Description
<b>Power Supply,</b> primary switch mode, flat design

Type	Order No.	Pcs. Pkt.
STEP-PS-100-240AC/5DC/4	29 38 91 8	1
STEP-PS-100-240AC/12DC/3	29 38 92 1	1
STEP-PS-100-240AC/15DC/2.4	29 38 93 4	1
STEP-PS-100-240AC/24DC/1.5	29 38 94 7	1
STEP-PS-100-240AC/48DC/0.75	29 38 95 0	1

Technical Data
Order No.

STEP-PS-100-240AC/...	...	...	...	...
...5DC/4	...12DC/3	...15DC/2.4	...24DC/1.5	...48DC/0.75
29 38 91 8	29 38 92 1	29 38 93 4	29 38 94 7	29 38 95 0

Input Data ①
Nominal input voltage
Input voltage range
Frequency
Current consumption (for nominal values)
Inrush current limiting/I <sup>2</sup> t (+25°C [+77°F])
Mains buffering for a nominal load (typical)
Switch-on time after applying the AC supply voltage
Transient surge voltage protection
Input fuse, internal
Recommended fuse

100 - 240 V AC (wide range input)  
 85 - 264 V AC/110 - 350 V DC  
 (with 95 - 110 V DC, 20% derating)  
 45 - 65 Hz/0 Hz  
 0.4 - 0.8 A  
 < 25 A/0.8 A<sup>2</sup>s  
 > 20 ms (120 V AC)/> 100 ms (230 V AC)  
 < 1 s  
 Varistor  
 1.25 AM (device protection)  
 Circuit breaker 16 A, Characteristic C (EN 60 898)



Output Data ②
Nominal output voltage U <sub>N</sub> (during convection cooling)
Tolerance
Nominal output current I <sub>N</sub> (up to +55°C [+131°F])
Maximum output current I <sub>max</sub> . (typical)
Startup of capacitive loads
System deviation on:
Load change static 10 - 90%
Load change dynamic 10 - 90%
Input voltage change ±10%
No load/nominal load
Maximum power loss
Efficiency (for nominal values)
Response time U <sub>OUT</sub> (10% - 90%)
Residual ripple/switching peaks (20 MHz)
Can be connected in parallel
Resistance to return supply

5 V DC	12 V DC	15 V DC	24 V DC	48 V DC
±1%				
4 A	3 A	2.4 A	1.5 A	0.75 A
11 A	9 A	7 A	4.5 A	2.5 A
Unlimited				
< 1%, typical				
< 3%, typical				
< 0.1%, typical				
< 2 W/8 W, approximately				
> 70%	> 80%	> 80%	> 80%	> 82%
< 100 ms, typical				
< 100 mV <sub>pp</sub> (for nominal values)				
To increase redundancy and power				
10 V DC	16 V DC	35 V DC	35 V DC	60 V DC

Signaling
POWER
OVERLOAD PROTECTION

Green LED  
 Red LED

**Power Supply, Primary Switch Mode, Flat Design – STEP-PS-100-240AC/...DC/...**

<b>General Data</b>		
Isolation voltage:	Input/output	4 kV AC (type test)/3 kV AC (routine test)
Approval package		EN 61 558-2-17
Safety transformers for switched-mode power supplies		EN 60950/VDE 0805,
Electrical safety (of IT equipment)		UL/C-UL Recognized UL 60 950  <sup>1)</sup>
Industrial control equipment		UL/C-UL Listed UL 508  <sup>1)</sup>
Equipping high voltage installations with electronic equipment		LISTED
Safety extra-low voltage		EN 50 178 (VDE 0160) (Surge Voltage Category III)
		PELV (EN 50 178)
		SELV (EN 60 950)
		VDE 0100-410
Safe isolation		
Protection against dangerous shock currents, basic requirements for safe isolation in electrical equipment		DIN VDE 0106-101
Limitation of harmonic line currents		According to EN 61000-3-2
Mounting position		On horizontal NS 35 DIN rail according to EN 50022
Can be mounted with spacing	- Vertical - Horizontal	≥ 3 cm (1.181 in.) 0 cm
Degree of protection		IP 20
Class of protection		II, (in closed control cabinets)
MTBF		> 500 000 h according to IEC 1709 (SN 29 500)
Housing version		Plastic PPE+PS GF10 FR, color green
Dimensions (W x H x D) + DIN rail		Default upon delivery: (71 x 90 x 57.8 mm [2.795 x 3.543 x 2.276 in.])
Weight		0.2 kg, approximately

<b>Climatic Data</b>		
Ambient temperature	Operation Storage	-25°C to +55°C (+32°F to +131°F) -40°C to +85°C (-40°F to +185°F)
Humidity		Up to 95% at +25°C (+77°F), no condensation
Vibration	according to IEC 68-2-6	< 15 Hz, amplitude ±2.5 mm/15 Hz - 150 Hz, 2.3 g
Shock	according to IEC 68-2-27	30 g all space directions
Degree of pollution		2 (according to EN 50 178)
Climatic category		3K3 (according to EN 60 721)

**CE**  
**Conforms to the EMC Directive 89/336/EEC and the Low Voltage Directive 73/23/EEC**

**EMC (Electromagnetic Compatibility)**  
**Noise Immunity According to EN 61000-6-2:**

Electrostatic discharge (ESD)	EN 61000-4-2 <sup>3)</sup>	Housing Contact discharge: Air discharge:
Electromagnetic HF field	EN 61000-4-3 <sup>2)</sup>	Housing Frequency: Field strength:
Fast transients (burst)	EN 61000-4-4 <sup>3)</sup>	Input: Output:
Surge current loads	EN 61000-4-5 <sup>3)</sup>	Input: Output:
Conducted interference	EN 61000-4-6 <sup>2)</sup>	I/O: Frequency: U <sub>0</sub> :
Voltage dips	EN 61000-4-11 <sup>3)</sup>	Input:
Simulation of radiophone	EN 50204	Frequency: Field strength:

**Noise Emission According to EN 50081-2:**

Radio interference	EN 55011
Radio interference	EN 55011

EN 55011 corresponds to CISPR11/EN 55022 corresponds to CISPR22  
 EN 61000 corresponds to IEC 1000

<sup>2)</sup>Criterion A: Normal operating characteristics within the specified limits.  
<sup>3)</sup>Criterion B: Temporary adverse effects on the operating characteristics that the device corrects independently.

<sup>1)</sup> UL approval for AC input voltage and ambient operating temperature up to +55°C (+131°F)

Requirements EN 61 000-6-2	STEP-PS-100-240AC/...DC/...
4 kV 8 kV	Level 3 6 kV 8 kV
80 - 1000 MHz 10 V/m	Level 3 80 - 1000 MHz/1.4 - 2.0 GHz 10 V/m
2 kV 2 kV	asymmetrical <sup>5)</sup> asymmetrical <sup>5)</sup>
4 kV (Level 4) 2 kV (Level 3)	
2 kV 1 kV 0.5 kV 0.5 kV	asymmetrical <sup>5)</sup> symmetrical <sup>4)</sup> asymmetrical <sup>5)</sup> symmetrical <sup>4)</sup>
2 kV (Level 3) 1 kV (Level 3) 0.5 kV (Level 1) 0.5 kV (Level 1)	
0.15 - 80 MHz 10 V	asymmetrical <sup>5)</sup> Level 3 0.15 - 80 MHz 10 V
30% reduction of the input voltage for 0.5 periods	See input data: Mains buffering > 20 ms
Not required	900 MHz/1800 MHz 20 V/m
Class A <sup>6)</sup>	EN 55011 (EN 55022) Class B <sup>7)</sup>
Class A <sup>6)</sup>	EN 55011 (EN 55022) Class B <sup>7)</sup>

<sup>4)</sup>symmetrical: Cable to cable  
<sup>5)</sup>asymmetrical: Cable to ground  
<sup>6)</sup>Class A: Industrial application  
<sup>7)</sup>Class B: Industrial and domestic applications

#### 4. Device View, Connections, and Control Elements

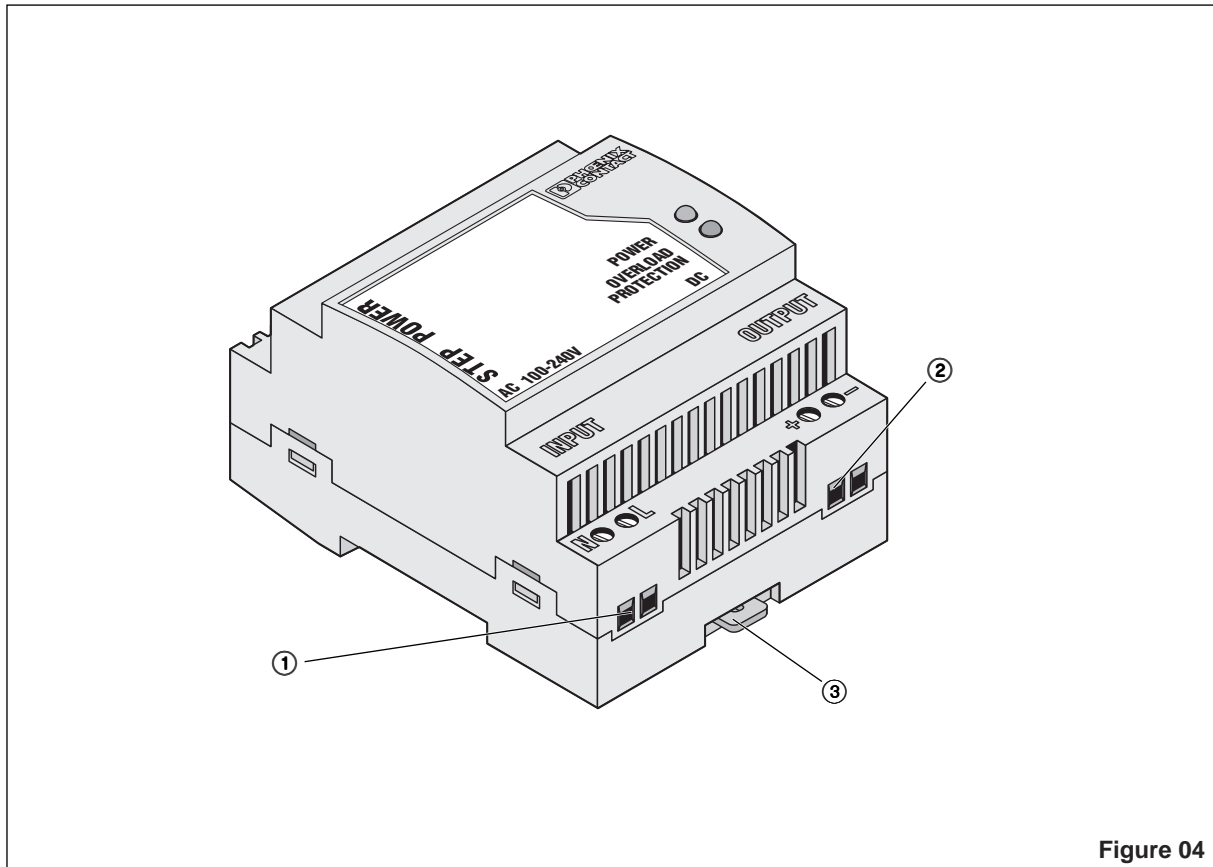

Figure 04

- ① **AC input:**  
(0.2 mm<sup>2</sup> to 2.5 mm<sup>2</sup>) (AWG 24 - 14)
- ② **DC output:**  
(0.2 mm<sup>2</sup> to 2.5 mm<sup>2</sup>) (AWG 24 - 14)  
Torque of the terminal screws: 0.5 - 0.6 Nm
- ③ **Universal latching foot for EN DIN rails**

- The device can be switched off outside the power supply according to EN 60950 regulations (e.g., by the line protection on the primary side).
- All supply lines have sufficient fuse protection and are the correct size.
- All output cables are the correct size for the maximum device output current or have separate fuse protection.
- Sufficient convection is ensured.

#### 5. Safety and Warning Instructions

To ensure that the device can be operated safely and all functions can be used, please read these instructions carefully.



**Caution: Never carry out work when the power is turned on, this is highly dangerous.**

**Installation and startup** must only be carried out by qualified personnel. The relevant country-specific regulations (e.g., VDE, DIN) must also be observed.

Before startup it is particularly important to ensure that:

- The line has been connected correctly and protection is provided against electric shock.

STEP POWER is a built-in device. After installation the terminal area must be covered to provide sufficient protection against unauthorized access to live parts. This is ensured by installing the device in the control cabinet or distributor box.

**The device contains dangerous live components and high levels of stored energy.**

Power Supply, Primary Switch Mode, Flat Design – STEP-PS-100-240AC/...DC/...

6. Installation

6.1. Mounting

The power supply can be snapped onto all DIN rails according to EN 50022-35. The device must be mounted horizontally (input terminals facing downwards).

Installation Dimensions

 To ensure sufficient convection, we recommend the following minimum spacing be used between modules:  
  
3.0 cm (1.181 in.) for vertical installation

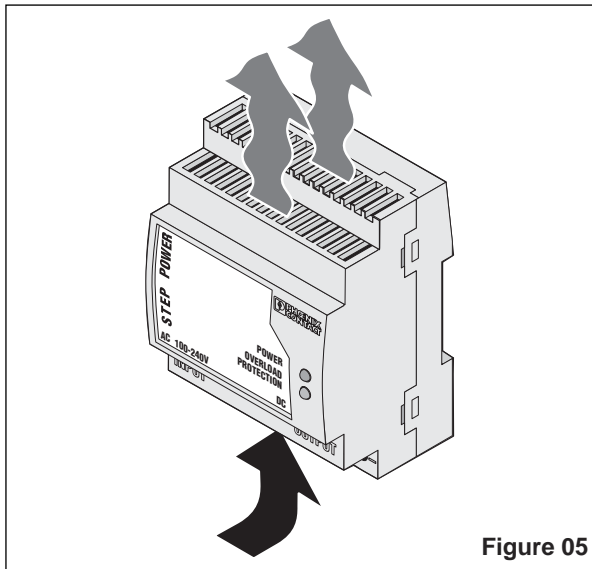

Figure 05

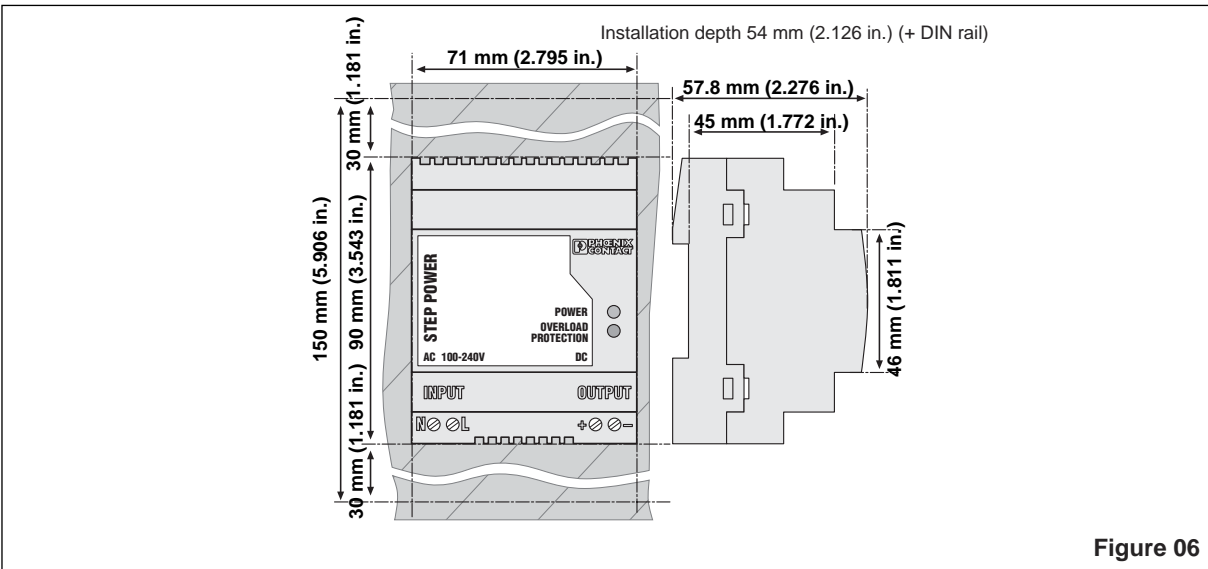

Figure 06

Mounting:

Place the module with the DIN rail guideway on the **top edge** of the DIN rail and then snap it **downwards**.

Removal:

Release the snap-on catch using a screwdriver and then detach the module from the **bottom edge** of the DIN rail.

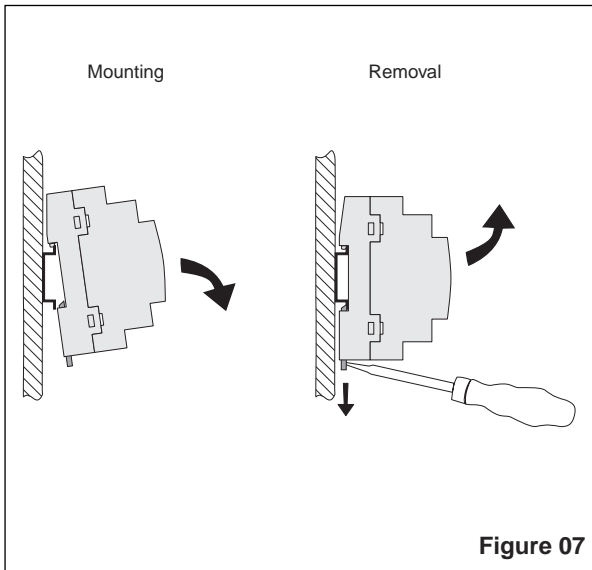

Figure 07

Power Supply, Primary Switch Mode, Flat Design – STEP-PS-100-240AC/...DC/...

6.2. Connection of Various Types of Network: 100-240 V AC networks

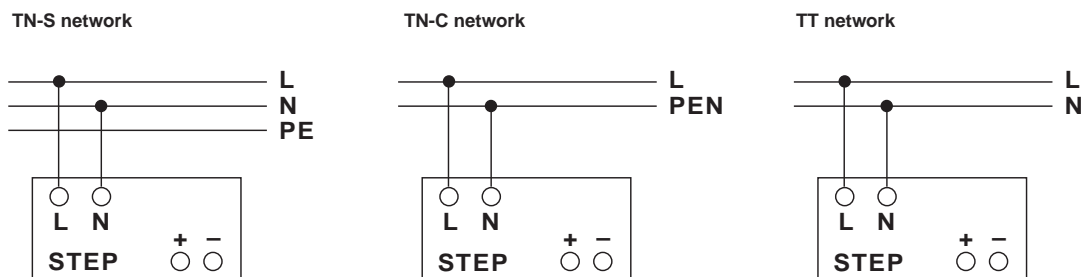

Figure 08

Connection Cable:

The following cable cross sections can be connected:

	Solid [mm <sup>2</sup> ]	Flexible [mm <sup>2</sup> ]	AWG	Torque [Nm]
① Input:	0.2 - 2.5	0.2 - 2.5	24 - 14	0.5 - 0.6
② Output:	0.2 - 2.5	0.2 - 2.5	24 - 14	0.5 - 0.6

For reliable and safe-to-touch connection: Strip 6.5 mm (0.26 in.) from the connector ends.

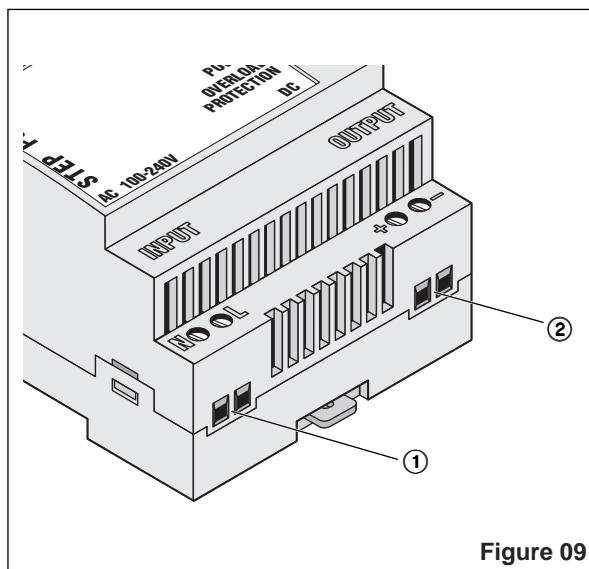
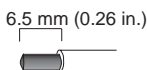

Figure 09

6.3. Input (①, Figure 9)

The 100 - 240 V AC connection is made using screw connections L and N.

Protecting the Primary Side

The device must be installed according to the specifications of EN 60 950. It must be possible to switch off the device using a suitable disconnecting device outside the power supply. For example, primary side line protection could be used.

Additional device protection is not required, as an internal fuse is present.

Recommended Fuse:

Circuit breaker 16 A, Characteristic C (or equivalent).  
A suitable fuse must be fitted for DC applications.



**If the internal fuse is blown, this is most probably due to a device fault. In this case, the device should be checked in the factory.**

**Power Supply, Primary Switch Mode, Flat Design – STEP-PS-100-240AC/...DC/...**

**6.4. Output (② , Figure 9)**

The DC connection is made using the "+" and "-" screw connections on the screw-cage connection ②.

**Protecting the Secondary Side:**

The device is electronic short-circuit-proof and idling-proof. It should be ensured that all output cables are the correct size for the maximum output current or have separate fuse protection.

The secondary side cables should have large cross sections to keep voltage drops on the cables to a minimum.

**Signaling**

The LEDs enable local function evaluation in the control cabinet.

<b>LED ON</b>	<b>a)</b> Normal operation of the power supply
<b>LED OFF</b>	<b>b)</b> Overload. The device switches to OVERLOAD PROTECTION mode after a few minutes to protect the load. The device is reset by isolating the AC supply voltage or load for a short period. <b>c)</b> Short circuit. The device starts automatically after the load short circuit has been removed.

POWER	LED (green)	a)	b)	c)
OVERLOAD PROTECTION	LED (red)			

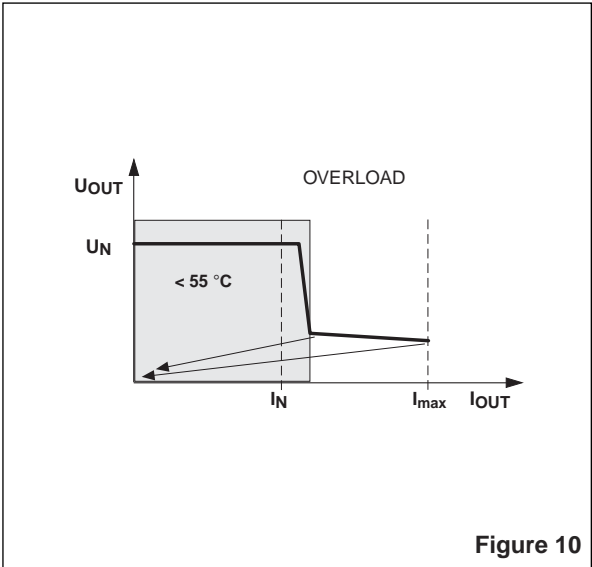

**Figure 10**

**7. Function**

**7.1. Output Characteristic Curve/Temperature Response**

The device supplies the nominal output current  $I_N$  up to an ambient temperature of  $+55^{\circ}\text{C}$  ( $+131^{\circ}\text{F}$ ). Operation above  $+55^{\circ}\text{C}$  ( $+131^{\circ}\text{F}$ ) leads to a thermal device shutdown.

The device can be switched on again after it has cooled down and has been isolated from the supply voltage for a short period.

## Power Supply, Primary Switch Mode, Flat Design – STEP-PS-100-240AC/...DC/...

### 7.2. Parallel Operation

Devices of the same type can be connected in parallel to increase both redundancy and power. The default setting does not have to be adjusted.

To ensure symmetrical current distribution we recommend that all cable connections from the power supply to the DIN rail are the same length and have the same cross section.

Depending on the system, for parallel connection of more than two power supplies a protective circuit should be installed at each individual device output (e.g., decoupling diode or DC fuse). This means that in the event of a secondary device fault high return currents are avoided.

### 7.3. Redundancy Operation

Redundant connections are designed for supplying systems, which place particularly high requirements on operational safety. If a fault occurs in the primary circuit of device no. 1, device no. 2 automatically takes over the complete power supply without interruption and vice versa.

For this purpose, the power supplies to be connected in parallel must be large enough that the total current requirements of all loads can be completely covered by one power supply. External decoupling diodes are required for 100% redundancy.

### 7.4. Power Increase

The output current can be increased to  $n \times I_N$  where  $n$  is the number of devices connected in parallel.

The parallel connection for power increase can be used to extend existing systems. A parallel connection is recommended if the power supply does not cover the current consumption of the most powerful load. Otherwise, the loads should be divided over independent individual devices.

A maximum of five devices can be connected in parallel.

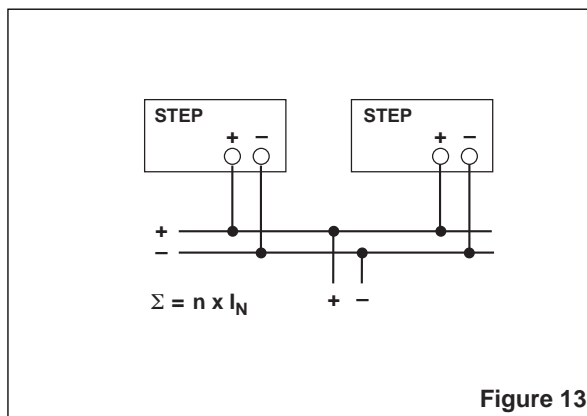
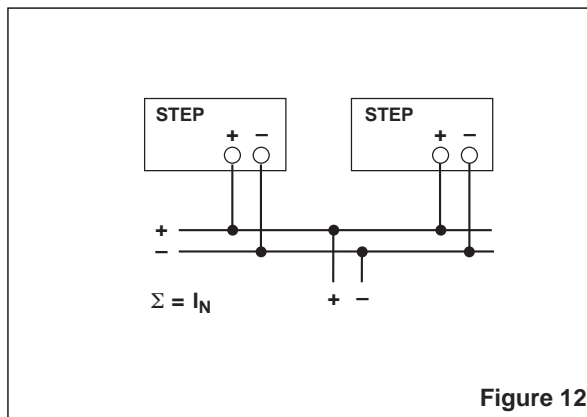



# SCATTERGOOD & JOHNSON LTD

ELECTRICAL ENGINEERING & FLUID CONTROL DISTRIBUTORS

Est.1899

At Scattergood & Johnson Ltd, we pride ourselves on being a technical distributor to specialist industries.

Working with a range of quality product suppliers across a number of specialist markets, we are not your average 'box shifter' - we are your technical and supply chain partner.

We fully support every product we sell - for free! Our internal team and external sales engineers can answer any product or application question, no matter the complexity.

Backing up this technical ability is a range of 50,000+ products available from stock for nationwide next day delivery (same day if required!), or you can collect what you need from any of our trade counters around the UK.

Select your specialist interest below to learn more about how we can help.



Online, In Branch and On the Road - Scattergood & Johnson Ltd, there when you need us.

# [www.scatts.co.uk](http://www.scatts.co.uk)