

EM-PB-GATEWAY-IFS

Application note for the EM-PB-GATEWAY-IFS and STEP 7 software

Application note
104303_en_01

© PHOENIX CONTACT 2011-11-08



1 Description

The EM-PB-GATEWAY-IFS is a module which enables connection of the EMM...IFS modules and PSR-TRISAFE to the PROFIBUS-DP. The module is certified in accordance with the DPV 1 specification (EN 50170).

The EM-PB-GATEWAY-IFS can communicate via the TBUS with up to 32 EMM...IFS modules. 8 digital inputs and 4 outputs can be freely parameterized.

The EM-PB-GATEWAY-IFS also supports Fail Safe: as the switching behavior can be influenced by the parameterization in the event of PROFIBUS errors. Digital switching outputs allow direct control of the EMM...IFS (forward/reverse running).

The GSD file (containing the communication characteristics of a PROFIBUS-DP device) can be found on the Internet at www.phoenixcontact.net/catalog.

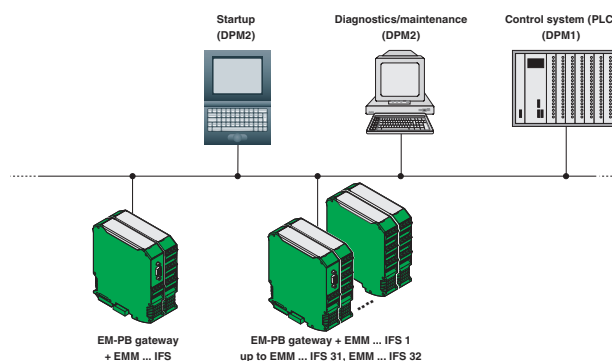

Figure 1 PROFIBUS gateway for electronic motor management modules



Make sure you always use the latest documentation.
It can be downloaded at www.phoenixcontact.net/catalog.

2 Downloading the GSD file

1. Access the Phoenix Contact Online Catalog (www.phoenixcontact.net/catalog) and search for "EM-PB-GATEWAY-IFS" or "2297620".
2. Select "Downloads".

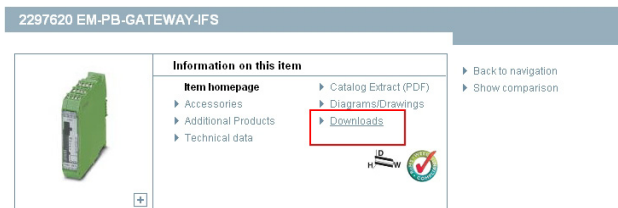

Figure 2 Selecting downloads in the Online Catalog

3. Click on the GSD file "PXC_0B51.gsd".

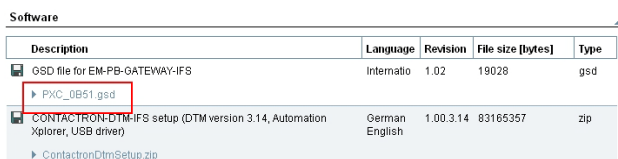

Figure 3 Selecting a GSD file in the Online Catalog

4. Read the General Terms and Conditions of Use.
5. Click "Accept" to confirm that you agree with the General Terms and Conditions of Use.

Before downloading the files, please accept the General Terms and Conditions for Use of Internet Downloads.



Figure 4 General Terms and Conditions of Use

6. Save the GSD file by clicking the "OK" button.

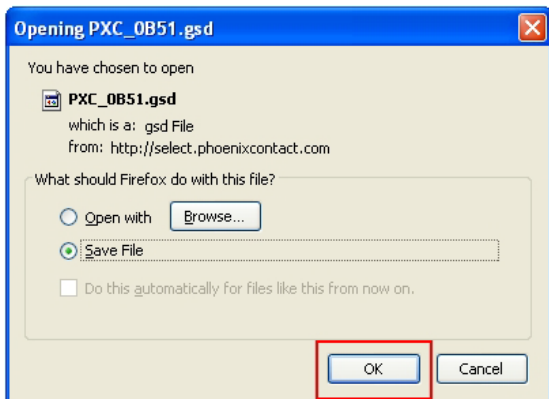

Figure 5 Saving the GSD file

3 Operating and indication elements of the EM-PB-GATEWAY-IFS

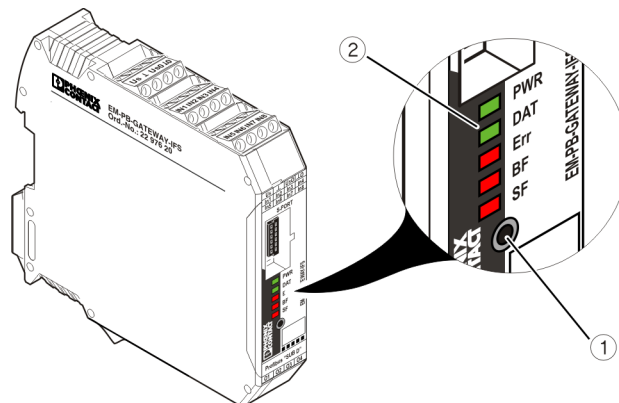

Figure 6 Operating and indication elements

- 1 Button for setting the PROFIBUS address
- 2 Status LEDs

i The status LEDs are used for displaying the PROFIBUS address and addresses of the connected IFS devices in parameterization mode during the address setting process.

4 Addressing example

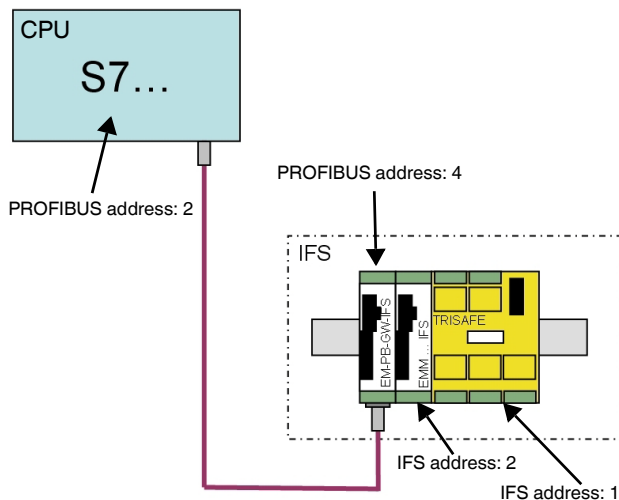

Figure 7 Addressing example

i The PSR-TRISAFE-... module must be assigned the IFS address1.

5 Setting the PROFIBUS address at the EM-PB-GATEWAY-IFS

1. Press button ① (see Figure 6 on page 2) at the EM-PB-GATEWAY-IFS for 6 seconds.
2. The LEDs ② at the EM-PB-GATEWAY-IFS display the current PROFIBUS address offset.
3. Set the PROFIBUS address offset by pressing the button ① at the EM-PB-GATEWAY-IFS (see table).
4. Press button ① at the EM-PB-GATEWAY-IFS for 6 seconds.



The EM-PB-GATEWAY-IFS calculates the PROFIBUS address by adding the offset to the base address.
The base address is set to 0 by default and can be modified by means of (DTM) or IFS-CONFSTICK software.

LED code					Offset
PWR	DAT	ERR	BF	SF	
0	0	0	0	0	0
0	0	0	0	1	1
0	0	0	1	0	2
0	0	0	1	1	3
0	0	1	0	0	4
0	0	1	0	1	5
0	0	1	1	0	6
0	0	1	1	1	7
0	1	0	0	0	8
0	1	0	0	1	9
0	1	0	1	0	10
0	1	0	1	1	11
0	1	1	0	0	12
0	1	1	0	1	13
0	1	1	1	0	14
0	1	1	1	1	15
1	0	0	0	0	16
1	0	0	0	1	17
1	0	0	1	0	18
1	0	0	1	1	19
1	0	1	0	0	20
1	0	1	0	1	21
1	0	1	1	0	22
1	0	1	1	1	23
1	1	0	0	0	24
1	1	0	0	1	25
1	1	0	1	0	26
1	1	0	1	1	27
1	1	1	0	0	28
1	1	1	0	1	29
1	1	1	1	0	30
1	1	1	1	1	31

Default offset

6 INTERFACE system addressing

1. Press button ① at the EM-PB-GATEWAY-IFS for 12 seconds.
2. The LEDs ② at the EM-PB-GATEWAY-IFS display the current IFS address of the first device on the IFS-Bus.
3. Set the IFS address by pressing the button ① at the EM-PB-GATEWAY-IFS (see table).
4. Press the button on the first device e.g.
EMM...IFS = Reset button
TRISAFE = Confirmation button
5. The IFS address is applied at the first device.
6. At the EM-PB-GATEWAY-IFS, the address of the next device is displayed. Repeat steps 3 and 4 until all devices have been addressed.
7. Press button ① at the EM-PB-GATEWAY-IFS for 12 seconds.
8. All status LEDs light up briefly.

LED code					IFSM address
PWR	DAT	ERR	BF	SF	
0	0	0	0	0	0
0	0	0	0	1	1
0	0	0	1	0	2
0	0	0	1	1	3
0	0	1	0	0	4
0	0	1	0	1	5
0	0	1	1	0	6
0	0	1	1	1	7
0	1	0	0	0	8
0	1	0	0	1	9
0	1	0	1	0	10
0	1	0	1	1	11
0	1	1	0	0	12
0	1	1	0	1	13
0	1	1	1	0	14
0	1	1	1	1	15
1	0	0	0	0	16
1	0	0	0	1	17
1	0	0	1	0	18
1	0	0	1	1	19
1	0	1	0	0	20
1	0	1	0	1	21
1	0	1	1	0	22
1	0	1	1	1	23
1	1	0	0	0	24
1	1	0	0	1	25
1	1	0	1	0	26
1	1	0	1	1	27
1	1	1	0	0	28
1	1	1	0	1	29
1	1	1	1	0	30
1	1	1	1	1	31

7 Integration in STEP 7

1. Start SIMATIC Manager



Figure 8 SIMATIC Manager icon

2. Create a new project

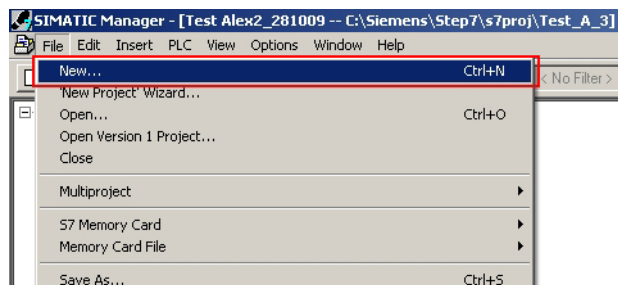

Figure 9 Creating a new project

3. Assign project name and click "OK"

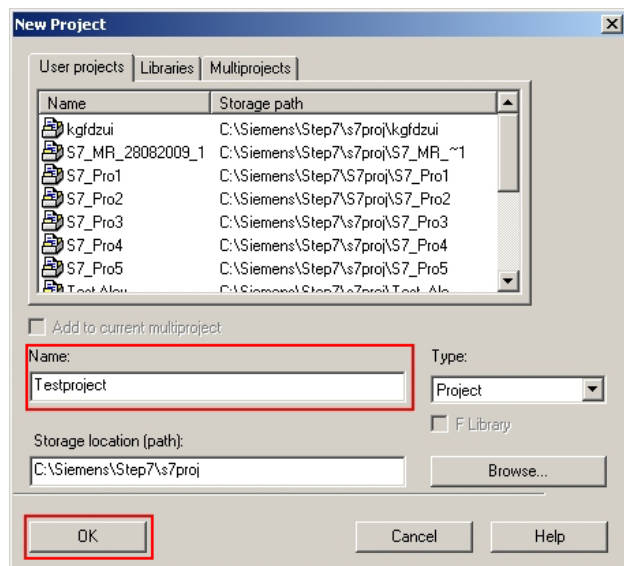

Figure 10 Saving project name

4. Under the menu command "Insert" > "Stations", select the appropriate CPU.

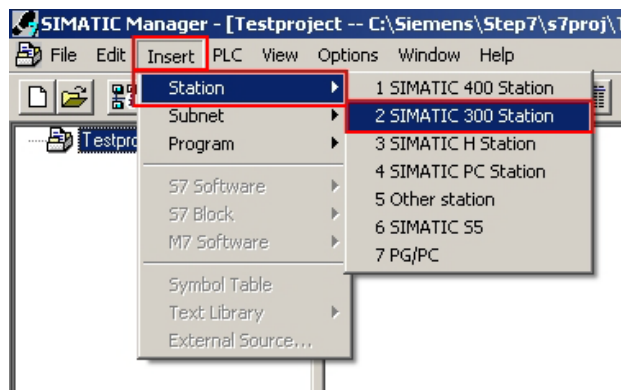

Figure 11 Selecting the CPU

5. The selected CPU is inserted into your project.

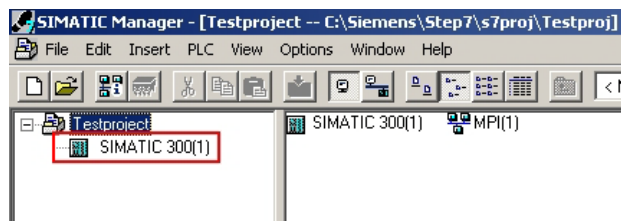

Figure 12 Selected CPU

6. Open the context menu of the inserted CPU. Click on "Open object".

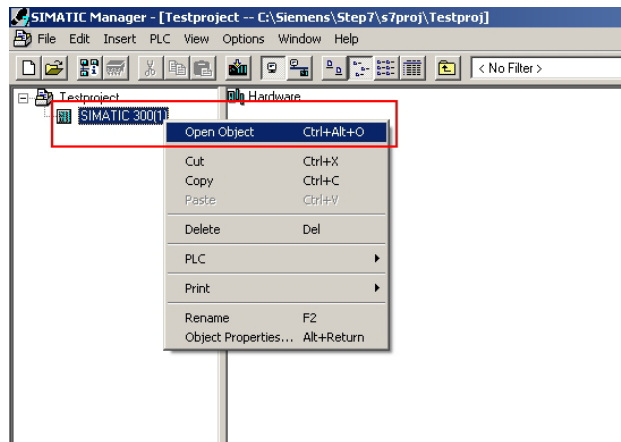

Figure 13 Opening the object

7. The hardware configuration is displayed.

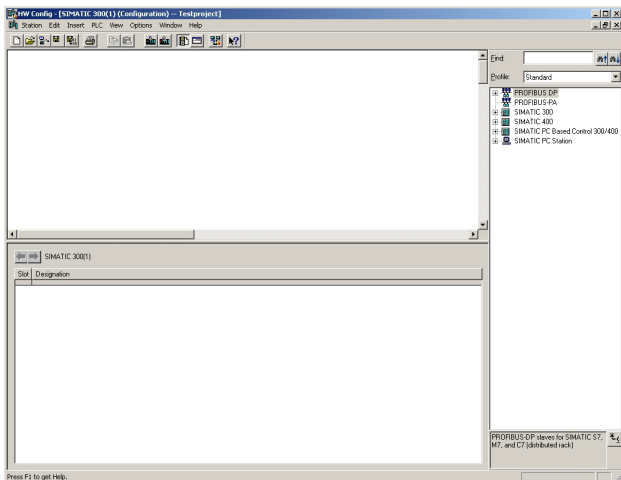

Figure 14 Hardware configuration

8. Close all application windows.

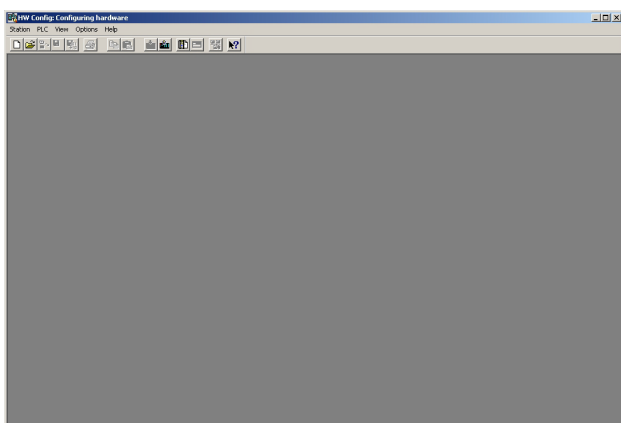

Figure 15 Hardware configuration

9. Open the "Options" menu and select the "Install New GSD..." command.

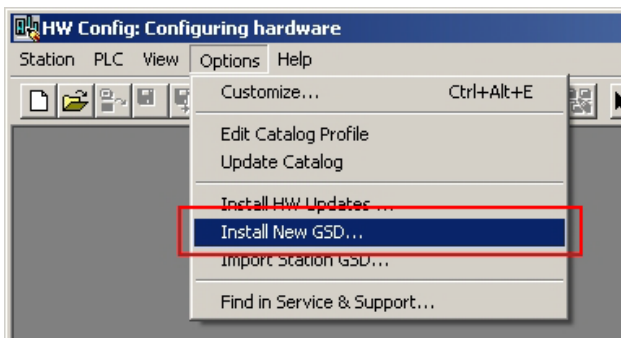

Figure 16 Installing a GSD file

10. Now load the GSD file downloaded in chapter 2.

11. If the "Installation has been completed successfully" message appears, you can close the hardware editor.

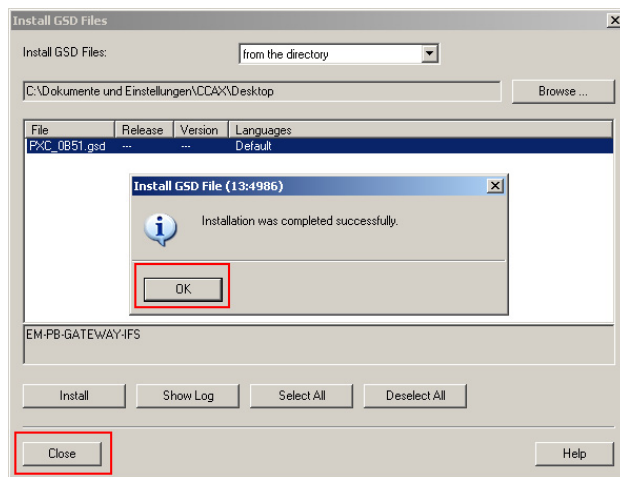

Figure 17 "Installation has been completed successfully" message

12. Open the context menu of the inserted CPU. Click on "Open object".

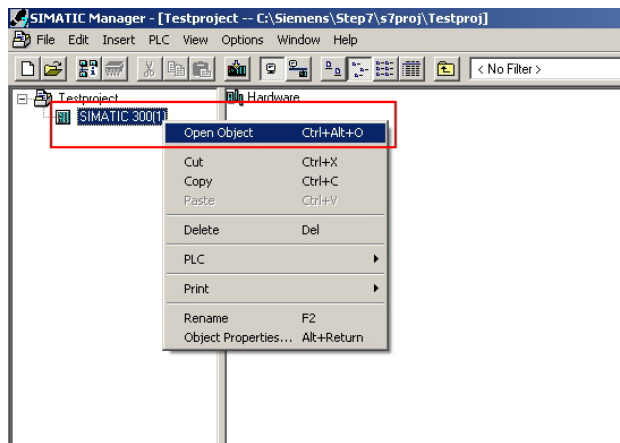

Figure 18 Opening the object

13. Open the "View" menu and then select "Catalog".

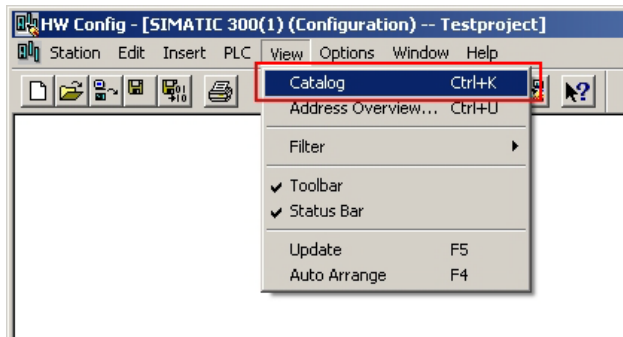

Figure 19 Selecting the catalog

14. The catalog window appears.

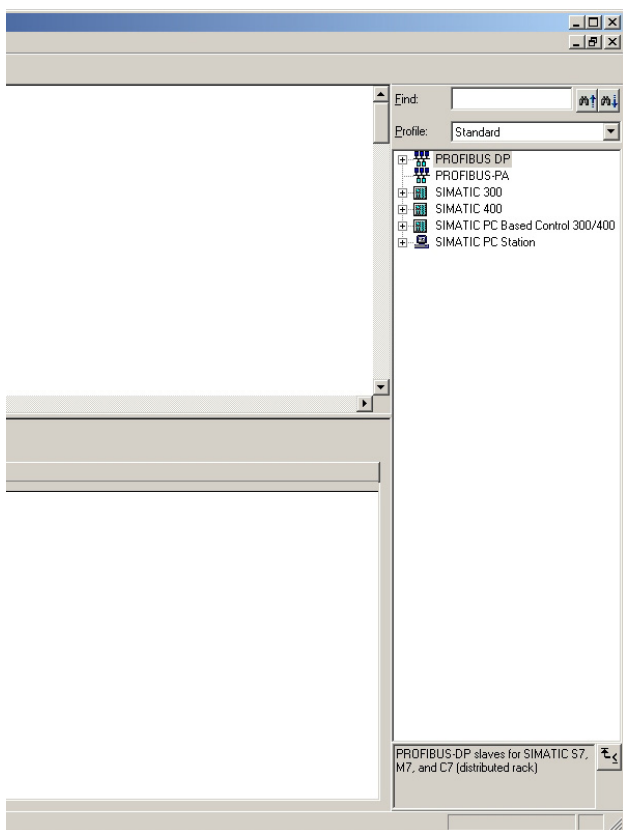

Figure 20 Catalog window

15. Suitable devices must now be inserted into your project here.

7.1 Example with SIMATIC 300

1. Select "SIMATIC 300" → "RACK 300" → "Rail" and insert this into your project.

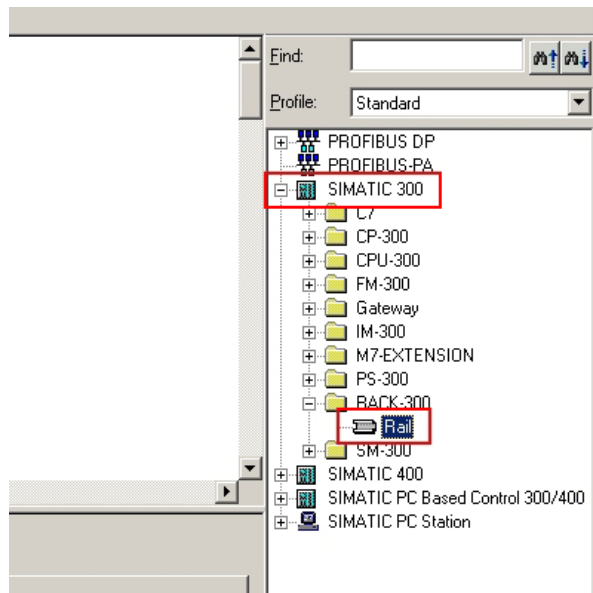

Figure 21 Selecting the DIN rail

2. Select "SIMATIC 300" → "CPU 315-2 DP" → "6ES7-315-2AF03-0AB0" → "V1.2" and insert this into your project.

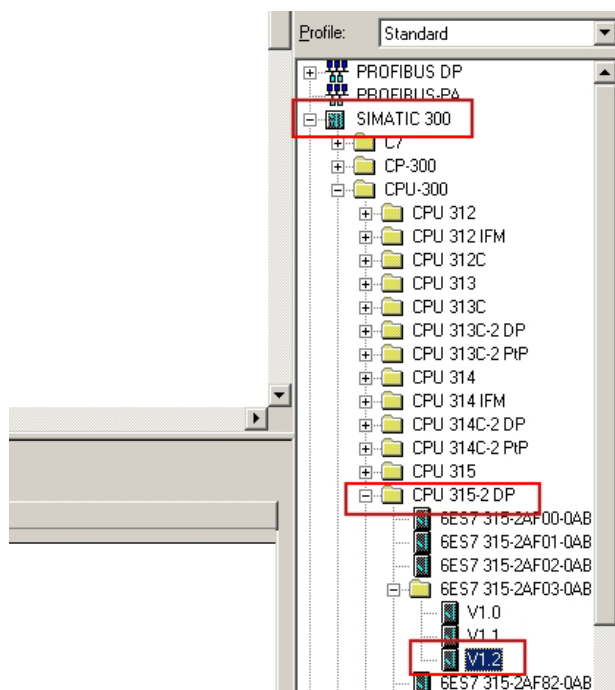

Figure 22 Selecting the CPU

- The "Properties" window appears. Click "New" and enter a new name for the bus line.

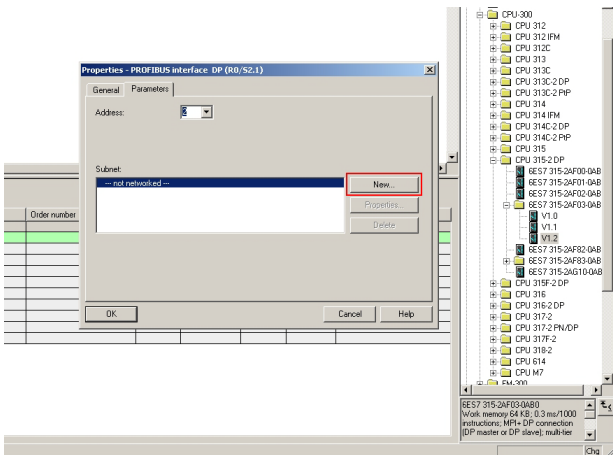

Figure 23 Bus line name

- Select "PROFIBUS-DP" → "Additional Field Devices" → "Gateway". Now move the EM-PB-GATEWAY-IFS into your project.

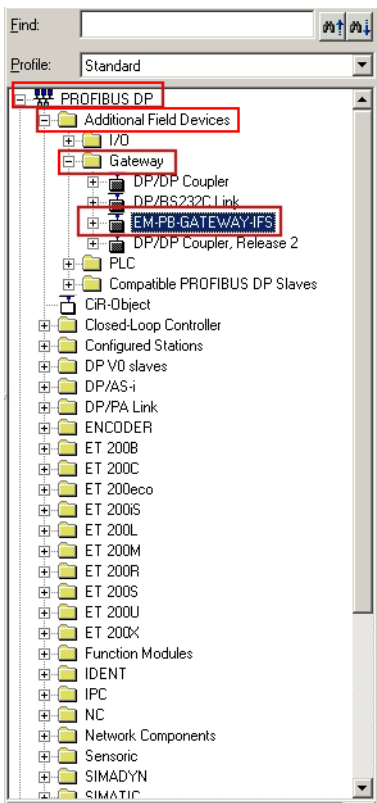

Figure 24 Selecting the gateway

- The "Properties" window appears. Under "Address", you must select the address which was configured in the EM-PB-GATEWAY-IFS in chapter 4.

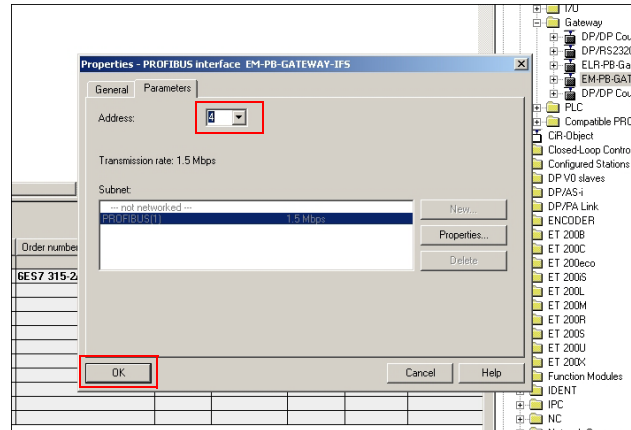

Figure 25 Gateway properties

- You can now move the required GSD data into your project from the Catalog window under the "EM-PB-GATEWAY-IFS" item.

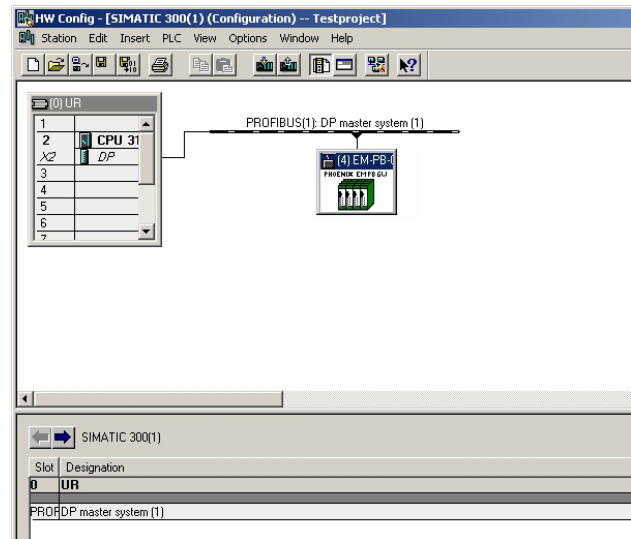

Figure 26 GSD data

8 Setting: byte order

1. Open the context menu of the EM-PB-GATEWAY-IFS and select "Object properties".
2. Activate the "Parameter Assignment" tab.

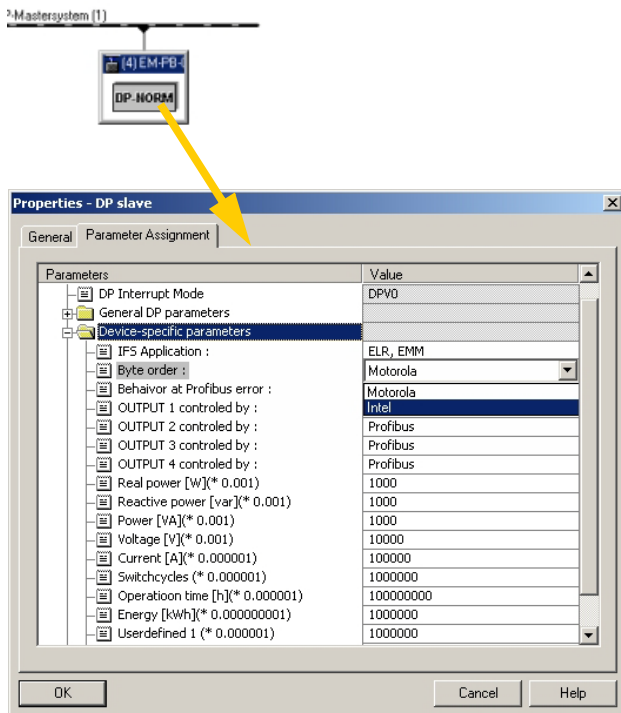

Figure 27 Setting the byte order

3. The byte order of the transferred data can be set here under "Device-specific parameters" by selecting "Byte order".

Motorola: Big Endian (the most significant byte is saved first of all)

Intel: Little Endian (the least significant byte is saved first of all)

8.1 Example: "EMM: COS φ" value

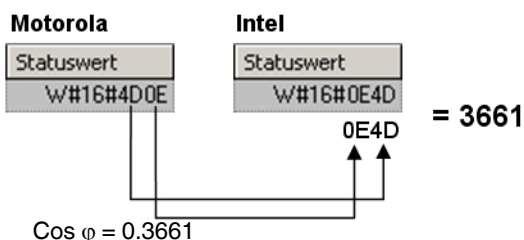

Figure 28 Example: "EMM: COS φ" value

9 Explanation of GSD data



A detailed description can be found on the package slip of the EM-PB-GATEWAY-IFS, which is provided with the product.

The package slip can also be downloaded from the Phoenix Contact Online Catalog.

1. Access the Phoenix Contact Online Catalog (www.phoenixcontact.net/catalog) and search for "EM-PB-GATEWAY-IFS" or "2297620".
2. Select "Downloads".

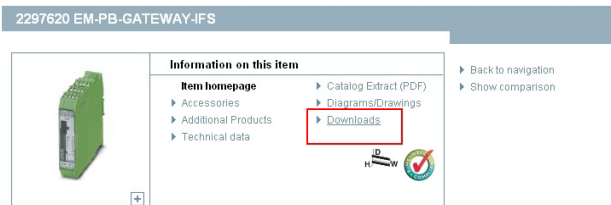

Figure 29 Selecting downloads in the Online Catalog

3. Click on the "packb_em_...pdf" package slip.

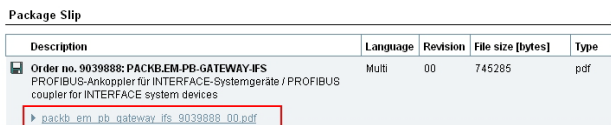

Figure 30 Selecting package slips in the Online Catalog

4. Save the pdf file or open if you wish to view the file.

9.1 GSD data for EM-PB-GATEWAY-IFS

Universal module
Digital inputs, outputs
Gateway: Module state
Gateway: Channel State 1
Gateway: Channel State 2
Gateway: Channel State 3
Gateway: Channel State 4
IFS: Slave Error State 1
IFS: Slave Error State 2
IFS: I/O State 1
IFS: I/O State 2

9.2 GSD data for EMM ... IFS

ELR, EMM Objects =====	
EMM: Control (Device:1)	← 1 = IFS address 1
EMM: Control (Device:2)	← 2 = IFS address 2
EMM: Control (Device:3)	← 3 = IFS address 3
EMM: Control (Device:4)	← 4 = IFS address 4
EMM: Control (Device:5)	← 5 = IFS address 5
EMM: Control (Device:6)	← 6 = IFS address 6
EMM: Control (Device:7)	← 7 = IFS address 7
EMM: Control (Device:8)	← 8 = IFS address 8
EMM: Status	
EMM: Module State 1	
EMM: Module State 2	
EMM: Channel State 1	
EMM: Channel State 2	
EMM: Channel State 3	
EMM: Channel State 4	
EMM: P(ALL)	
EMM: U(L1)	
EMM: U(L2)	
EMM: U(L3)	
EMM: I(L1)	
EMM: I(L2)	
EMM: I(L3)	
EMM: Electric Work	
EMM: COS PHI	
EMM: Frequency	
EMM: Operation time (left)	
EMM: Operation time (right)	
EMM: Cycle (left)	
EMM: Cycle (right)	
EMM: P(L1)	
EMM: P(L2)	
EMM: Q(ALL)	
EMM: S(ALL)	
EMM: SQRT(3) * U(L1)	
EMM: SQRT(3) * U(L2)	
EMM: SQRT(3) * U(L3)	



If a PSR-TRISAFE is used, the IFS address 1 must not be assigned to an EMM.

9.3 GSD data for PSR-TRISAFE-S

TriSafe Objects =====	
PSR-TS-S : Device 1	← 1 = IFS address 1
PSR-TS-S : Input 15 ... 0	← Safe inputs: I0 ... I15
PSR-TS-S : Input 19 ... 16	← Safe inputs: I16 ... I19
PSR-TS-S : SafeOut 3 ... 0	← Safe outputs: O0 ... O3
PSR-TS-S : UnSafeOut 15 ... 0	← Monitoring outputs: M0 ... M3

9.4 GSD data for PSR-TRISAFE-M

TriSafe Objects =====	
PSR-TS-M : Device 1	← 1 = IFS address 1
PSR-TS-M : Safe IN w01	← Safe inputs: I0 ... I15
PSR-TS-M : Safe IN w02	← Safe inputs: I16 ... I19
PSR-TS-M : Safe OUT w01	← Safe outputs: O0 ... O3
PSR-TS-M : Diag IN w03	← Diagnostic LEDs: PWR, DATA, ERR, CONF
PSR-TS-M : None Safe OUT w01	← Monitoring outputs: M0 ... M3 and external signals: EQ00 ,... EQ11
PSR-TS-M : None Safe OUT w02	← External signals: EQ12 ... EQ27
PSR-TS-M : None Safe OUT w03	← External signals: EQ28 ... EQ43
PSR-TS-M : None Safe OUT w04	← External signals: EQ44 ... EQ59
PSR-TS-M : None Safe OUT w05	← External signals: EQ60 ... EQ63



The "EMM: Control (Device: X)" control word is used simultaneously for assigning the values listed below to a suitable IFS address of the EMM to be addressed.

- Should you wish to integrate values from the EMM with the IFS address 1, the "EMM: Control (Device:1)" word must be inserted into the structure first of all.

All the words inserted there now relate to the EMM 1, until another control word is inserted with a different address.

10 Example

The following modules are used in this example:

- SIMATIC S7-300
- EM-PB-GATEWAY-IFS
- EMM 3-24DC/500AC-16-IFS
- PSR-SCP-24DC/TS/S

10.1 Hardware structure

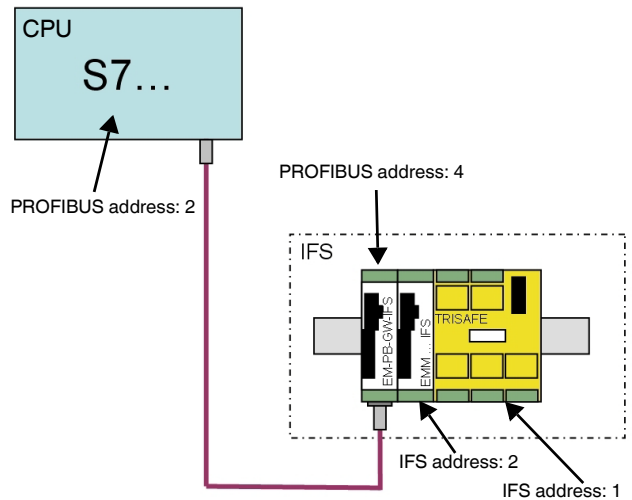

Figure 31 Hardware structure

10.2 Applied GSD values



Order Number / Designation
Digital inputs, outputs

Inputs and outputs of the EM-PB-GATEWAY-IFS



Order Number / Designation
EMM : Control (Device:2)
EMM : Status
EMM : P{ALL}
EMM : Frequency
EMM : Operation time(left)
EMM : Operation time(right)
EMM : Cycle(left)
EMM : Cycle(right)
EMM : U(L1)
EMM : U(L2)
EMM : U(L3)
EMM : I(L1)
EMM : I(L2)
EMM : I(L3)

- Control word of the EMM, e. g. forward running, reverse running, stop,
- Status word of the EMM, e. g. input state, direction of motor
- Display: real power total
- Display: frequency
- Display: operating hours counter (reverse running)
- Display: operating hours counter (forward running)
- Display: cycles (reverse running)
- Display: cycles (forward running)
- Display: voltage L1
- Display: voltage L2
- Display: voltage L3
- Display: current L1
- Display: current L2
- Display: current L3

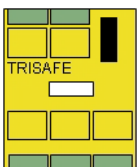

Order Number / Designation
TriSafe : Device 1
TriSafe : Master Input 15..0
TriSafe : Master Input 19..16
TriSafe : Master SafeOut 3..0
TriSafe : Master UnSafeOut 15..0

- Must be set (PSR-TRISAFE-S is assigned IFS address 1)
- Display: safe inputs I0 ... I15
- Display: safe inputs I16 ... I19
- Display: safe outputs O0 ... O3
- Display: monitoring outputs M0 ... M3

10.3 Monitoring variables

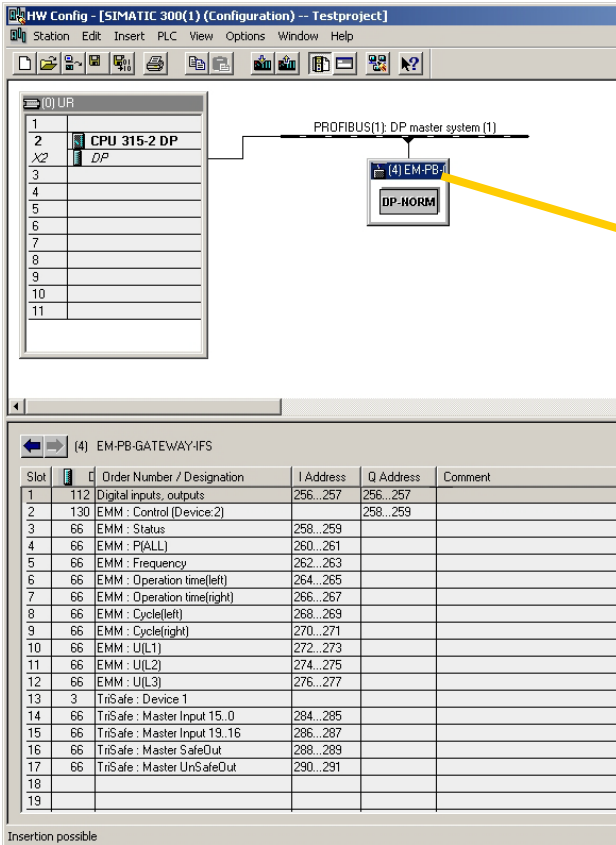

Figure 32 Opening the context menu of the EM-PB-GATEWAY-IFS

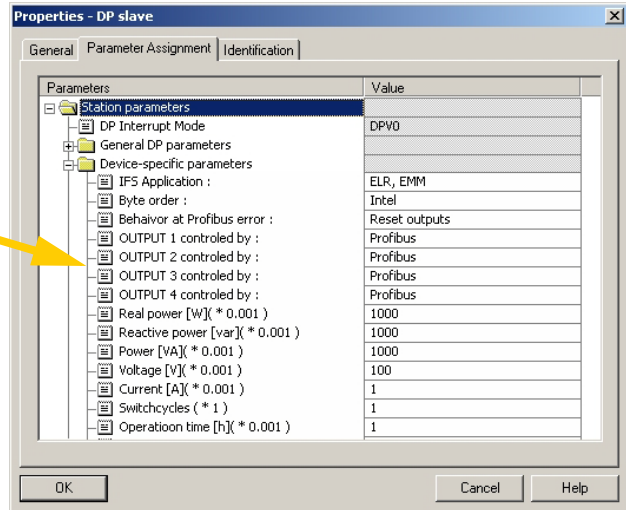
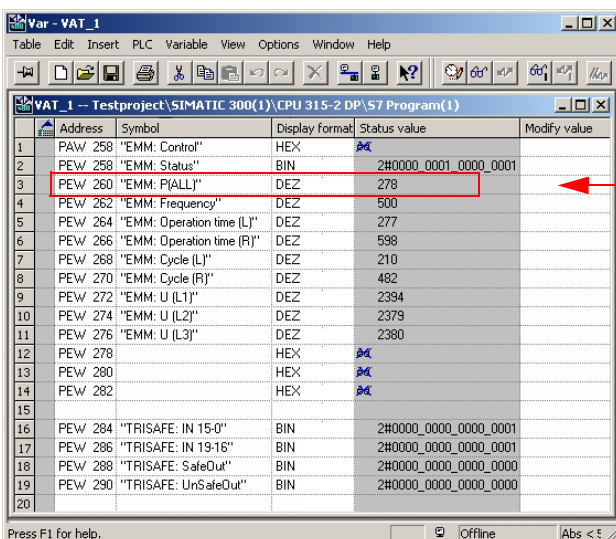

Figure 33 Object properties of the EM-PB-GATEWAY-IFS

- In the object properties of the EM-PB-GATEWAY-IFS, the conversion factors for the measured values can be specified.



- In the variable overview, individual values can now be displayed.

In the example image, you can see, for example, that the real power (All) amounts to 278 W.



For each EM-PB-GATEWAY-IFS, a maximum of 32 words can be transferred in the cycle (66 ms).

Figure 34 Variable overview



SCATTERGOOD & JOHNSON LTD

ELECTRICAL ENGINEERING & FLUID CONTROL DISTRIBUTORS

Est.1899

At Scattergood & Johnson Ltd, we pride ourselves on being a technical distributor to specialist industries.

Working with a range of quality product suppliers across a number of specialist markets, we are not your average 'box shifter' - we are your technical and supply chain partner.

We fully support every product we sell - for free! Our internal team and external sales engineers can answer any product or application question, no matter the complexity.

Backing up this technical ability is a range of 50,000+ products available from stock for nationwide next day delivery (same day if required!), or you can collect what you need from any of our trade counters around the UK.

Select your specialist interest below to learn more about how we can help.

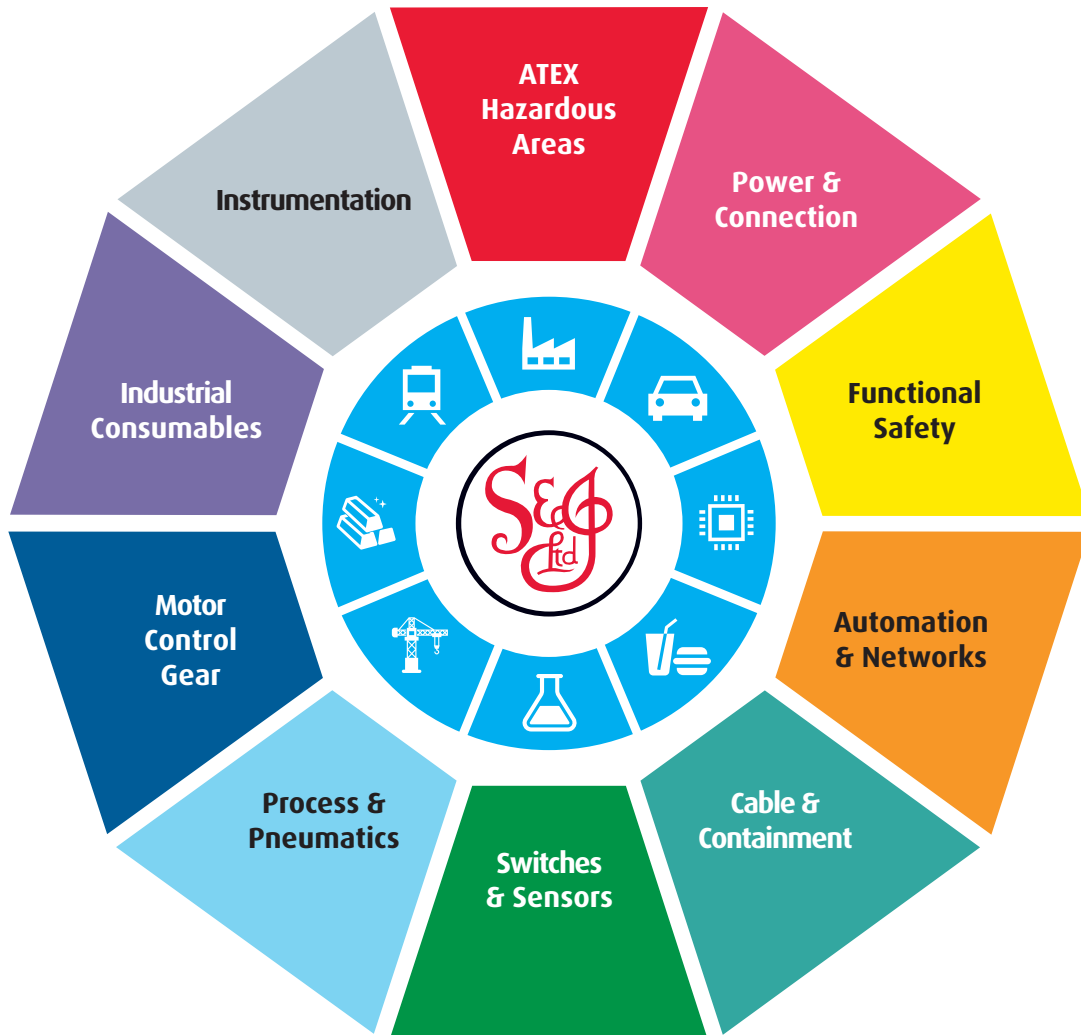

Online, In Branch and On the Road - Scattergood & Johnson Ltd, there when you need us.

www.scatts.co.uk