

PSR-MS and PSR-MC

Applications using PSR-MS and PSR-MC safety relays from the PSRmini product range

Application note
106509_en_01

© PHOENIX CONTACT 2015-08-27



1 Description

Our PSR safety relays demonstrate that innovative safety solutions do not necessarily have to be complex in order to meet the high requirements of machine building and systems manufacturing.

As well as offering easy integration and handling, the modules are characterized by their compact, space-saving design as well as their high quality, safety, and reliability.

In particular, safety applications can be implemented under optimum cost-benefit conditions with the new PSRmini safety relay range.

Solutions for all common applications

Use the PSRmini safety relays, for example, to implement monitoring of the following safety equipment:

- Emergency stop
- Safety door
- Light grid
- Magnetic switch

PSR-MS

- Single or two-channel control
- 1 enabling current path
- 6.8 mm housing width

PSR-MC

- Single or two-channel control
- 2 or 3 enabling current paths
- 12.5 mm housing width



Make sure you always use the latest documentation.
It can be downloaded at phoenixcontact.net/products.



This document is valid for the products listed in the "Ordering data".

PSR-MS and PSR-MC**Table of contents**

Description	1
Ordering data	5
Documentation	6
Applications with the PSR-MS20	7
Emergency stop monitoring/automatic start	7
Safety door monitoring/automatic start	7
Connection to failsafe controller/automatic start	8
Applications with the PSR-MS25	9
Emergency stop monitoring/manual, monitored start	9
Safety door monitoring/manual, monitored start	9
Connection to failsafe controller/manual, monitored start	10
Applications with the PSR-MS30	11
Emergency stop monitoring/automatic start	11
Safety door monitoring/automatic start	11
Magnetic switch monitoring/automatic start	12
Applications with the PSR-MS35	13
Emergency stop monitoring/manual, monitored start	13
Safety door monitoring/manual, monitored start	13
Magnetic switch monitoring/manual, monitored start	14
Applications with the PSR-MS40	15
Emergency stop monitoring/automatic start	15
Safety door monitoring/automatic start	15
Magnetic switch monitoring/automatic start	16
Applications with the PSR-MS45	17
Emergency stop monitoring/manual, monitored start	17
Safety door monitoring/manual, monitored start	17
Magnetic switch monitoring/manual, monitored start	18
Applications with the PSR-MS50	19
Magnetic switch monitoring/automatic start	19
Applications with the PSR-MS55	19
Magnetic switch monitoring/manual, monitored start	19
Applications with the PSR-MS60	20
Light grid monitoring/automatic start	20
Two-channel control via LPSDO module	20
Single-channel control via failsafe controller	21
Applications with the PSR-MC20	22
Emergency stop monitoring/automatic start	22
Emergency stop monitoring/manual, monitored start	22
Safety door monitoring/automatic start	23

Safety door monitoring/manual, monitored start	23
Connection to failsafe controller/automatic start	24
Applications with the PSR-MC30	25
Emergency stop monitoring/automatic start	25
Emergency stop monitoring/manual, monitored start	25
Safety door monitoring/automatic start	26
Safety door monitoring/automatic start/without cross-circuit detection	26
Single-channel safety door monitoring/automatic start	27
Safety door monitoring/manual, monitored start	27
Safety door monitoring/manual, monitored start/without cross-circuit detection	28
Single-channel safety door monitoring/manual, monitored start	28
Magnetic switch monitoring/automatic start	29
Magnetic switch monitoring/manual, monitored start	29
Applications with the PSR-MC34	30
Emergency stop monitoring/automatic start	30
Emergency stop monitoring/manual, monitored start	30
Safety door monitoring/automatic start	31
Safety door monitoring/automatic start/without cross-circuit detection	31
Single-channel safety door monitoring/automatic start	32
Safety door monitoring/manual, monitored start	32
Safety door monitoring/manual, monitored start/without cross-circuit detection	33
Single-channel safety door monitoring/manual, monitored start	33
Magnetic switch monitoring/automatic start	34
Magnetic switch monitoring/manual, monitored start	34
Applications with the PSR-MC40	35
Emergency stop monitoring/automatic start	35
Emergency stop monitoring/manual, monitored start	35
Safety door monitoring/automatic start	36
Safety door monitoring/manual, monitored start	36
Single-channel safety door monitoring/automatic start	37
Single-channel safety door monitoring/manual, monitored start	37
Connection to failsafe controller/automatic start	38
Connection to failsafe controller/manual, monitored start	38
Single-channel connection to failsafe controller/automatic start	39
Single-channel connection to failsafe controller/manual, monitored start	39
Light grid monitoring/automatic start	40
Light grid monitoring/manual, monitored start	40
Transponder monitoring/automatic start	41
Transponder monitoring/manual, monitored start	41
Applications with the PSR-MC50	42
Magnetic switch monitoring/automatic start	42
Magnetic switch monitoring/manual, monitored start	42
Safety door monitoring/automatic start	43
Safety door monitoring/manual, monitored start	43

PSR-MS and PSR-MC

Revision history 44

2 Ordering data

Application note

Applications using PSR-MS and PSR-MC safety relays from the PSRmini product range

Designation: AH EN PSR-MS / PSR-MC
 Revision: 01
 MNR/Revision: 52007563/00

PSR-MS

Description	Type	Order No.	Pcs. / Pkt.
Safety relay for emergency stop and safety doors up to SIL 1, SILCL 1, Cat. 1, PL c, depending on the application up to SIL 3, SILCL 3, Cat. 4, PL e, 1-channel operation, automatic start, 1 enabling current path, $U_S = 24$ V DC, fixed screw terminal block	PSR-MS20-1NO-1DO-24DC-SC	2904950	1
Safety relay for emergency stop and safety doors up to SIL 1, SILCL 1, Cat. 1, PL c, depending on the application up to SIL 3, SILCL 3, Cat. 4, PL e, 1-channel operation, manual, monitored start, 1 enabling current path, $U_S = 24$ V DC, fixed screw terminal block	PSR-MS25-1NO-1DO-24DC-SC	2904951	1
Safety relay for emergency stop and safety doors up to SIL 3, SILCL 3, Cat. 4, PL e, 2-channel operation, automatic start, cross-circuit detection, 1 enabling current path, $U_S = 24$ V DC, fixed screw terminal block	PSR-MS30-1NO-24DC-SC	2904952	1
Safety relay for emergency stop and safety doors up to SIL 3, SILCL 3, Cat. 4, PL e, 2-channel operation, manual, monitored start, cross-circuit detection, 1 enabling current path, $U_S = 24$ V DC, fixed screw terminal block	PSR-MS35-1NO-24DC-SC	2904953	1
Safety relay for emergency stop and safety doors up to SIL 3, SILCL 3, Cat. 4, PL e, 2-channel operation, automatic start, 1 enabling current path, $U_S = 24$ V DC, fixed screw terminal block	PSR-MS40-1NO-1DO-24DC-SC	2904954	1
Safety relay for emergency stop and safety doors up to SIL 3, SILCL 3, Cat. 4, PL e, 2-channel operation, manual, monitored start, 1 enabling current path, $U_S = 24$ V DC, fixed screw terminal block	PSR-MS45-1NO-1DO-24DC-SC	2904955	1
Safety relay for monitoring non-equivalent signal generators up to SIL 3, SILCL 3, Cat. 4, PL e, 2-channel, non-equivalent operation, automatic start, 1 enabling current path, $U_S = 24$ V DC, fixed screw terminal block	PSR-MS50-1NO-1DO-24DC-SC	2904956	1
Safety relay for monitoring non-equivalent signal generators up to SIL 3, SILCL 3, Cat. 4, PL e, 2-channel, non-equivalent operation, manual, monitored start, 1 enabling current path, $U_S = 24$ V DC, fixed screw terminal block	PSR-MS55-1NO-1DO-24DC-SC	2904957	1
Safety relay for emergency stop, safety doors and light grids up to SIL 3, SILCL 3, Cat. 4, PL e, 2-channel operation, automatic start, 2 enabling current paths (1-channel), $U_S = 24$ V DC, fixed screw terminal block	PSR-MS60-2NO-24DC-SC	2904958	1

PSR-MC

Description	Type	Order No.	Pcs. / Pkt.
Safety relay for emergency stop and safety doors up to SIL 1, SILCL 1, Cat. 1, PL c, depending on the application up to SIL 3, SILCL 3, Cat. 4, PL e, 1-channel operation, automatic/manual start, 3 enabling current paths, $U_S = 24$ V DC, plug-in screw terminal block	PSR-MC20-3NO-1DO-24DC-SC	2700466	1
Safety relay for emergency stop and safety doors up to SIL 1, SILCL 1, Cat. 1, PL c, depending on the application up to SIL 3, SILCL 3, Cat. 4, PL e, 1-channel operation, automatic/manual start, 3 enabling current paths, $U_S = 24$ V DC, plug-in spring-cage terminal block	PSR-MC20-3NO-1DO-24DC-SP	2700467	1
Safety relay for emergency stop and safety doors up to SIL 3, SILCL 3, Cat. 4, PL e, 2-channel operation, automatic or manual, monitored start, cross-circuit detection, 2 enabling current paths, $U_S = 24$ V DC, plug-in screw terminal block	PSR-MC30-2NO-1DO-24DC-SC	2700498	1

PSR-MS and PSR-MC

Description	Type	Order No.	Pcs. / Pkt.
Safety relay for emergency stop and safety doors up to SIL 3, SILCL 3, Cat. 4, PL e, 2-channel operation, automatic or manual, monitored start, cross-circuit detection, 2 enabling current paths, Us = 24 V DC, plug-in spring-cage terminal block	PSR-MC30-2NO-1DO-24DC-SP	2700499	1
Safety relay for emergency stop and safety doors up to SIL 3, SILCL 3, Cat. 4, PL e, 2-channel operation, automatic or manual, monitored start, cross-circuit detection, 3 enabling current paths, Us = 24 V DC, plug-in screw terminal block	PSR-MC34-3NO-1DO-24DC-SC	2700540	1
Safety relay for emergency stop and safety doors up to SIL 3, SILCL 3, Cat. 4, PL e, 2-channel operation, automatic or manual, monitored start, cross-circuit detection, 3 enabling current paths, Us = 24 V DC, plug-in spring-cage terminal block	PSR-MC34-3NO-1DO-24DC-SP	2700548	1
Safety relay for emergency stop, safety doors and light grids up to SIL 3, SILCL 3, Cat. 4, PL e, 2-channel operation, automatic or manual, monitored start, 3 enabling current paths, Us = 24 V DC, plug-in screw terminal block	PSR-MC40-3NO-1DO-24DC-SC	2700569	1
Safety relay for emergency stop, safety doors and light grids up to SIL 3, SILCL 3, Cat. 4, PL e, 2-channel operation, automatic or manual, monitored start, 3 enabling current paths, Us = 24 V DC, plug-in spring-cage terminal block	PSR-MC40-3NO-1DO-24DC-SP	2700570	1
Safety relay for monitoring non-equivalent signal generators up to SIL 3, SILCL 3, Cat. 4, PL e, 2-channel, non-equivalent operation, automatic or manual, monitored start, 3 enabling current paths, Us = 24 V DC, plug-in screw terminal block	PSR-MC50-3NO-1DO-24DC-SC	2700553	1
Safety relay for monitoring non-equivalent signal generators up to SIL 3, SILCL 3, Cat. 4, PL e, 2-channel, non-equivalent operation, automatic or manual, monitored start, 3 enabling current paths, Us = 24 V DC, plug-in spring-cage terminal block	PSR-MC50-3NO-1DO-24DC-SP	2700564	1

3 Documentation



Further documentation for individual products can be downloaded at phoenixcontact.net/products.

4 Applications with the PSR-MS20

Key:

- S1 = Emergency-stop button
- B1 = Mechanical safety door switch
- K1/K2 = Contactors

4.1 Emergency stop monitoring/automatic start

- Single-channel emergency stop monitoring
- Automatic start
- Monitoring of external contactors
- Suitable up to category 1, PL c (EN ISO 13849-1), SIL 1 (EN 62061)



Contactor K2 is not essential in order to achieve category 1.

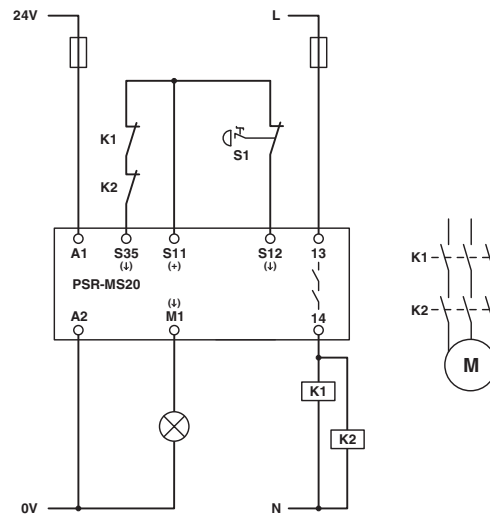

Figure 1 Emergency stop monitoring/automatic start

4.2 Safety door monitoring/automatic start

- Single-channel safety door monitoring
- Automatic start
- Monitoring of external contactors
- Suitable up to category 1, PL c (EN ISO 13849-1), SIL 1 (EN 62061)



Contactor K2 is not essential in order to achieve category 1.

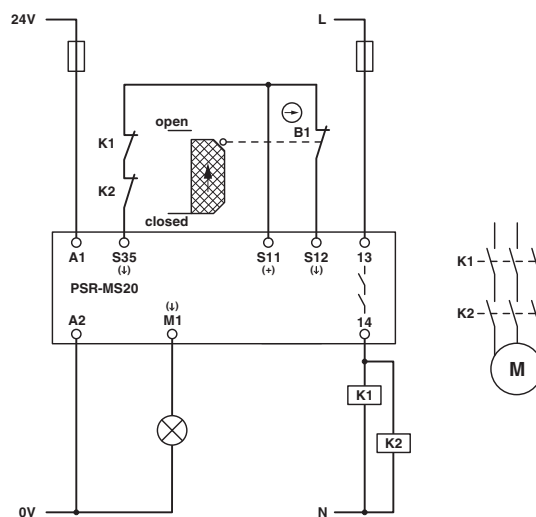

Figure 2 Safety door monitoring/automatic start

PSR-MS and PSR-MC

4.3 Connection to failsafe controller/automatic start

- Automatic start
- Monitoring of external contactors
- Suitable up to category 4, PL e (EN ISO 13849-1), SIL 3 (EN 62061), if the digital output of the safety-related controller meets PL e, SIL 3, and cross-circuits can be ruled out



WARNING: Loss of functional safety!
 Make sure that the signal generator (e.g., PLC output card or light grid) and the safety relay have the same ground potential.



Cross-circuits in the cable installation can be excluded if the failsafe PLC, safety relay, and external contactors K1 and K2 are located in the same electrical installation space.

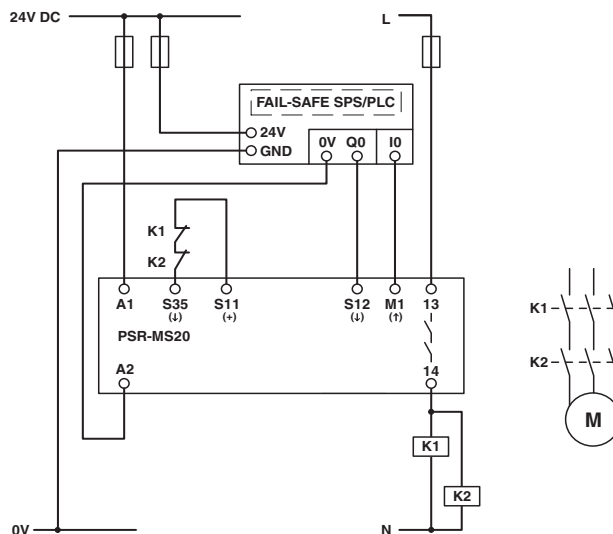

Figure 3 Connection to failsafe PLC/automatic start

5 Applications with the PSR-MS25

Key:

- S1 = Emergency-stop button
- S2 = Manual reset device
- B1 = Mechanical safety door switch
- K1/K2 = Contactors

5.1 Emergency stop monitoring/manual, monitored start

- Single-channel emergency stop monitoring
- Manual, monitored start
- Monitoring of external contactors
- Suitable up to category 1, PL c (EN ISO 13849-1), SIL 1 (EN 62061)



Contactor K2 is not essential in order to achieve category 1.

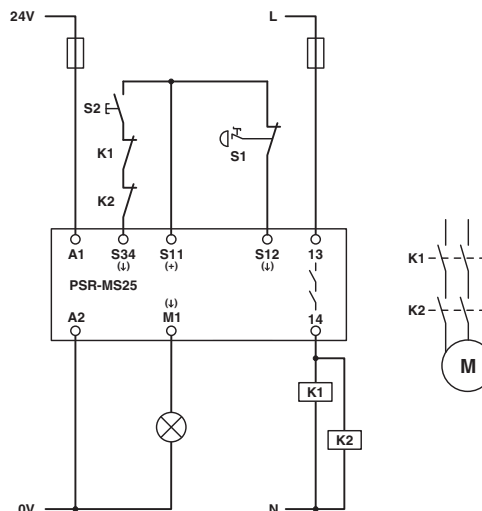

Figure 4 Emergency stop monitoring/manual, monitored start

5.2 Safety door monitoring/manual, monitored start

- Single-channel safety door monitoring
- Manual, monitored start
- Monitoring of external contactors
- Suitable up to category 1, PL c (EN ISO 13849-1), SIL 1 (EN 62061)



Contactor K2 is not essential in order to achieve category 1.

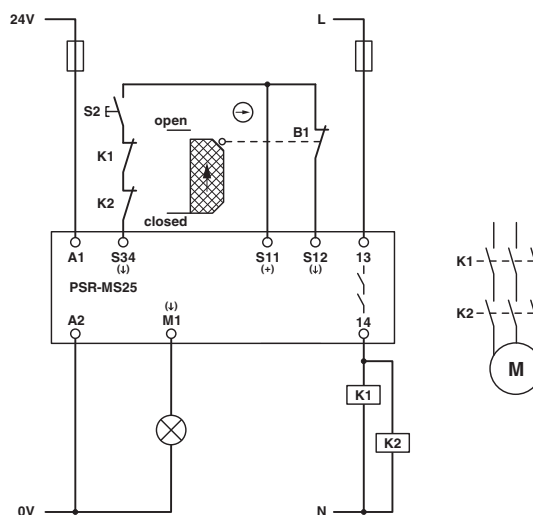

Figure 5 Safety door monitoring/manual, monitored start

PSR-MS and PSR-MC

5.3 Connection to failsafe controller/manual, monitored start

- Manual, monitored start
- Monitoring of external contactors
- Suitable up to category 4, PL e (EN ISO 13849-1), SIL 3 (EN 62061), if the digital output of the safety-related controller meets PL e, SIL 3, and cross-circuits can be ruled out



WARNING: Loss of functional safety!

Make sure that the signal generator (e.g., PLC output card or light grid) and the safety relay have the same ground potential.



Cross-circuits in the cable installation can be excluded if the failsafe PLC, safety relay, and external contactors K1 and K2 are located in the same electrical installation space.

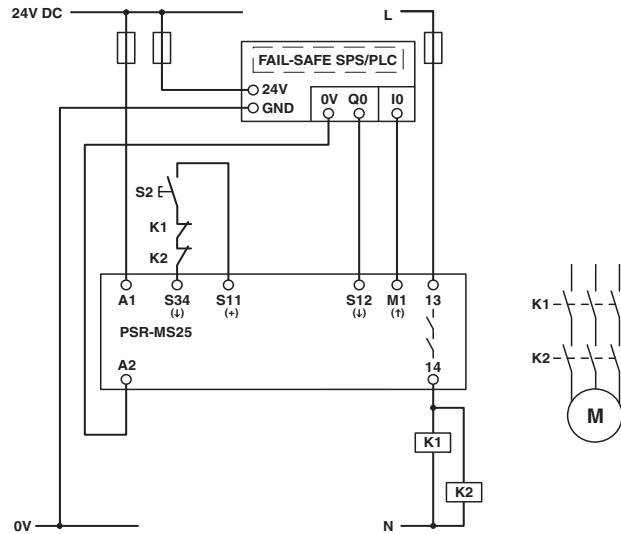

Figure 6 Connection to failsafe PLC/manual, monitored start

6 Applications with the PSR-MS30

Key:

- S1 = Emergency-stop button
- S3 = Magnetic switch
- B1/B2 = Mechanical safety door switches
- K1/K2 = Contactors



Cross-circuits in the cable installation can be excluded if the safety relay and external contactors K1 and K2 are located in the same electrical installation space.

6.1 Emergency stop monitoring/automatic start

- Two-channel emergency stop monitoring
- Automatic start
- Monitoring of external contactors
- Suitable up to category 4, PL e (EN ISO 13849-1), SIL 3 (EN 62061), if cross-circuits in the control to the actuator can be ruled out

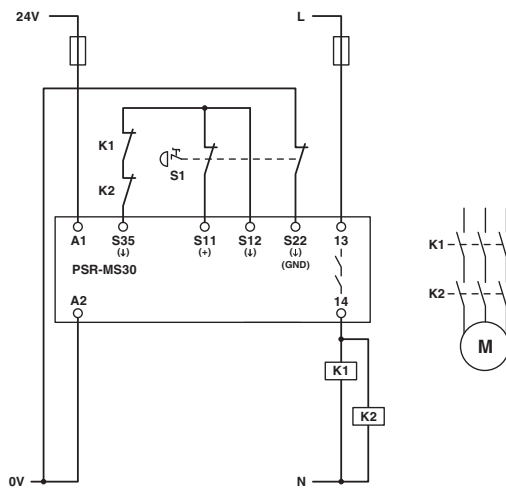

Figure 7 Emergency stop monitoring/automatic start

6.2 Safety door monitoring/automatic start

- Two-channel safety door monitoring
- Automatic start
- Monitoring of external contactors
- Suitable up to category 4, PL e (EN ISO 13849-1), SIL 3 (EN 62061), if cross-circuits in the control to the actuator can be ruled out

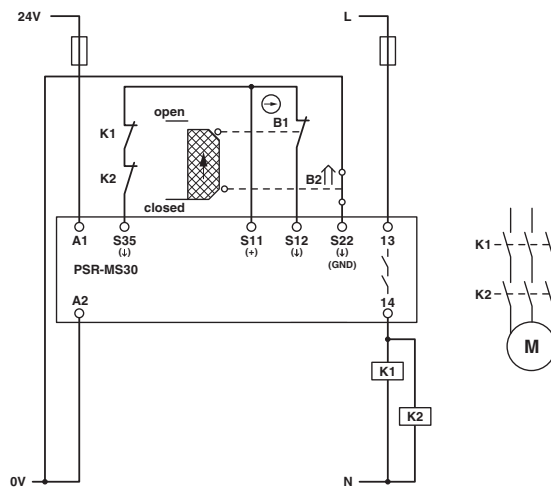

Figure 8 Safety door monitoring/automatic start

PSR-MS and PSR-MC

6.3 Magnetic switch monitoring/automatic start

- Two-channel magnetic switch monitoring
- Automatic start
- Monitoring of external contactors
- Suitable up to category 4, PL e (EN ISO 13849-1), SIL 3 (EN 62061), if cross-circuits in the control to the actuator can be ruled out

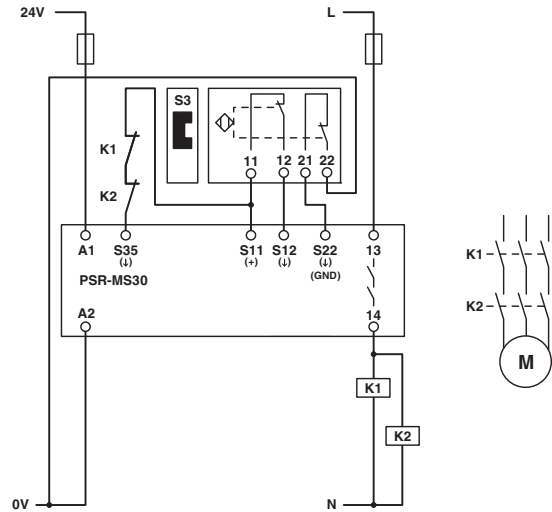

Figure 9 Magnetic switch monitoring/automatic start

7 Applications with the PSR-MS35

Key:

- S1 = Emergency-stop button
- S2 = Manual reset device
- S3 = Magnetic switch
- B1/B2 = Mechanical safety door switches
- K1/K2 = Contactors



Cross-circuits in the cable installation can be excluded if the safety relay and external contactors K1 and K2 are located in the same electrical installation space.

7.1 Emergency stop monitoring/manual, monitored start

- Two-channel emergency stop monitoring
- Manual, monitored start
- Monitoring of external contactors
- Suitable up to category 4, PL e (EN ISO 13849-1), SIL 3 (EN 62061), if cross-circuits in the control to the actuator can be ruled out

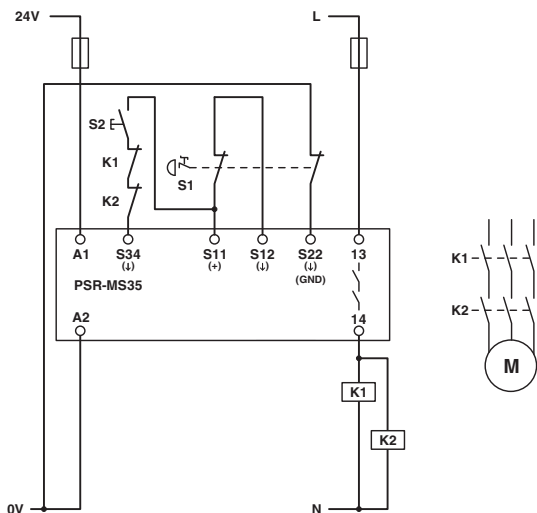

Figure 10 Emergency stop monitoring/manual, monitored start

7.2 Safety door monitoring/manual, monitored start

- Two-channel safety door monitoring
- Manual, monitored start
- Monitoring of external contactors
- Suitable up to category 4, PL e (EN ISO 13849-1), SIL 3 (EN 62061), if cross-circuits in the control to the actuator can be ruled out

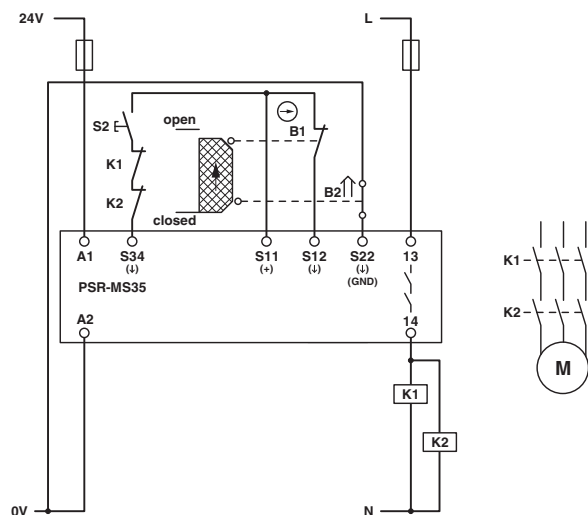

Figure 11 Safety door monitoring/manual, monitored start

PSR-MS and PSR-MC

7.3 Magnetic switch monitoring/manual, monitored start

- Two-channel magnetic switch monitoring
- Manual, monitored start
- Monitoring of external contactors
- Suitable up to category 4, PL e (EN ISO 13849-1), SIL 3 (EN 62061), if cross-circuits in the control to the actuator can be ruled out

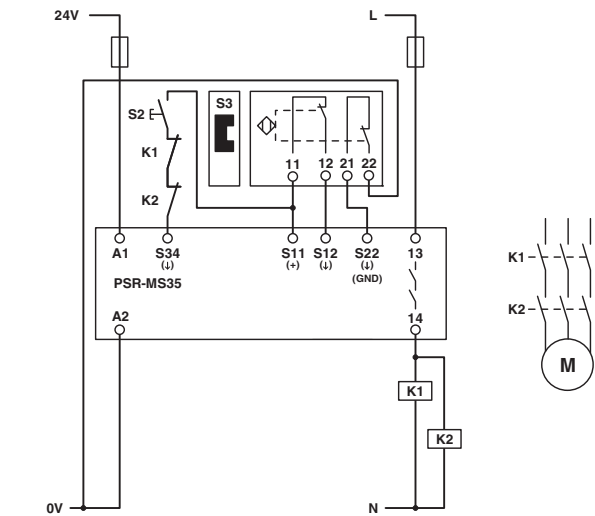

Figure 12 Magnetic switch monitoring/manual, monitored start

8 Applications with the PSR-MS40

Key:

- S1 = Emergency-stop button
 S3 = Magnetic switch
 B1/B2 = Mechanical safety door switches
 K1/K2 = Contactors



Cross-circuits in the cable installation can be excluded if the safety relay and external contactors K1 and K2 are located in the same electrical installation space.

8.1 Emergency stop monitoring/automatic start

- Two-channel emergency stop monitoring
- Automatic start
- Monitoring of external contactors
- No cross-circuit detection in the sensor circuit
- Suitable up to category 4, PL e (EN ISO 13849-1), SIL 3 (EN 62061), if cross-circuits in the control to the actuator and the sensor circuit can be ruled out

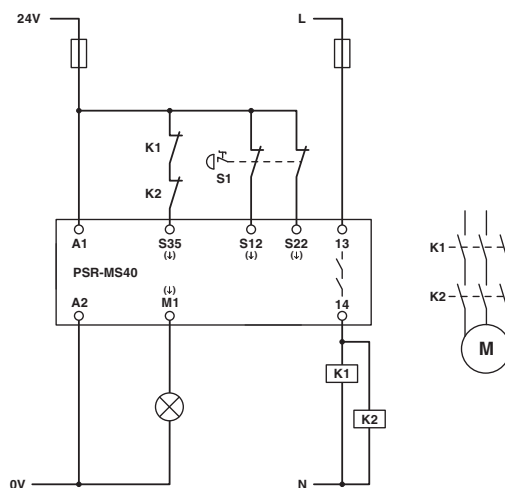

Figure 13 Emergency stop monitoring/automatic start

8.2 Safety door monitoring/automatic start

- Two-channel safety door monitoring
- Automatic start
- Monitoring of external contactors
- No cross-circuit detection in the sensor circuit
- Suitable up to category 4, PL e (EN ISO 13849-1), SIL 3 (EN 62061), if cross-circuits in the control to the actuator and the sensor circuit can be ruled out

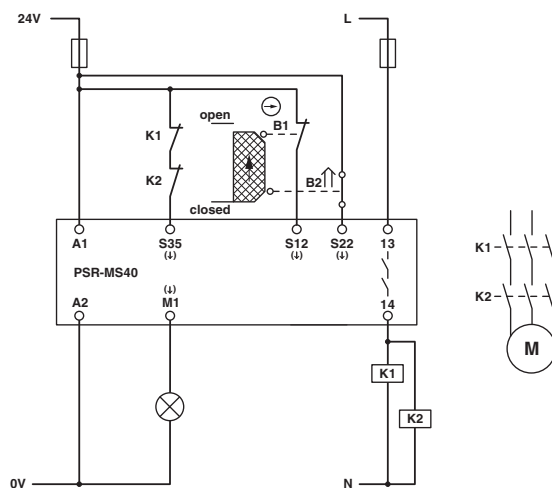

Figure 14 Safety door monitoring/automatic start

PSR-MS and PSR-MC

8.3 Magnetic switch monitoring/automatic start

- Two-channel magnetic switch monitoring
- Automatic start
- Monitoring of external contactors
- No cross-circuit detection in the sensor circuit
- Suitable up to category 4, PL e (EN ISO 13849-1), SIL 3 (EN 62061), if cross-circuits in the control to the actuator and the sensor circuit can be ruled out

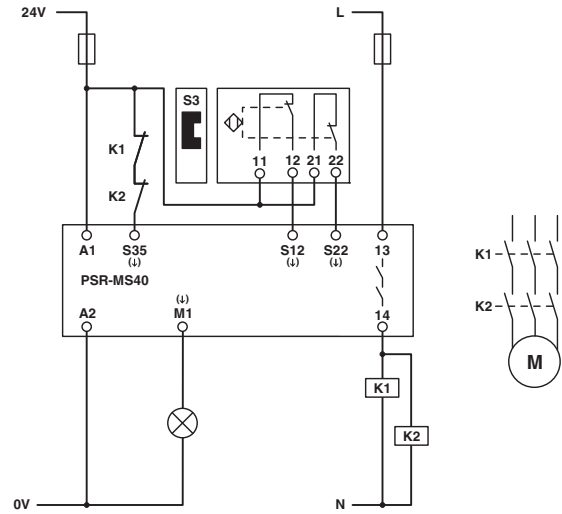

Figure 15 Magnetic switch monitoring/automatic start

9 Applications with the PSR-MS45

Key:

- S1 = Emergency-stop button
- S2 = Manual reset device
- S3 = Magnetic switch
- B1/B2 = Mechanical safety door switches
- K1/K2 = Contactors



Cross-circuits in the cable installation can be excluded if the safety relay and external contactors K1 and K2 are located in the same electrical installation space.

9.1 Emergency stop monitoring/manual, monitored start

- Two-channel emergency stop monitoring
- Manual, monitored start
- Monitoring of external contactors
- No cross-circuit detection in the sensor circuit
- Suitable up to category 4, PL e (EN ISO 13849-1), SIL 3 (EN 62061), if cross-circuits in the control to the actuator and the sensor circuit can be ruled out

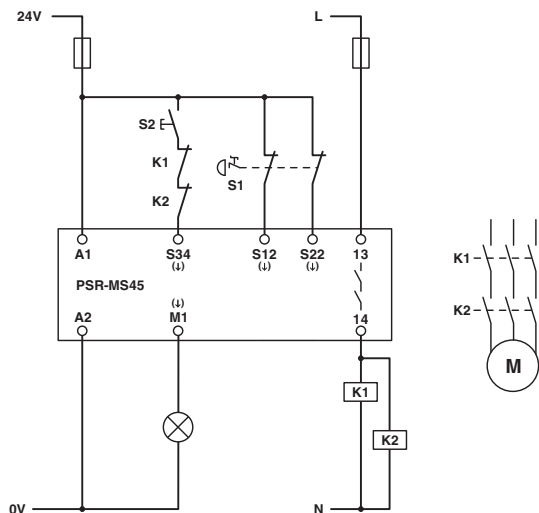

Figure 16 Emergency stop monitoring/manual, monitored start

9.2 Safety door monitoring/manual, monitored start

- Two-channel safety door monitoring
- Manual, monitored start
- Monitoring of external contactors
- No cross-circuit detection in the sensor circuit
- Suitable up to category 4, PL e (EN ISO 13849-1), SIL 3 (EN 62061), if cross-circuits in the control to the actuator and the sensor circuit can be ruled out

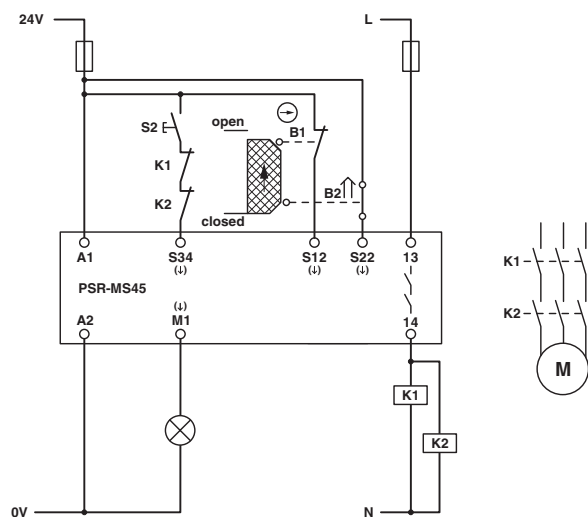

Figure 17 Safety door monitoring/manual, monitored start

PSR-MS and PSR-MC

9.3 Magnetic switch monitoring/manual, monitored start

- Two-channel magnetic switch monitoring
- Manual, monitored start
- Monitoring of external contactors
- No cross-circuit detection in the sensor circuit
- Suitable up to category 4, PL e (EN ISO 13849-1), SIL 3 (EN 62061), if cross-circuits in the control to the actuator and the sensor circuit can be ruled out

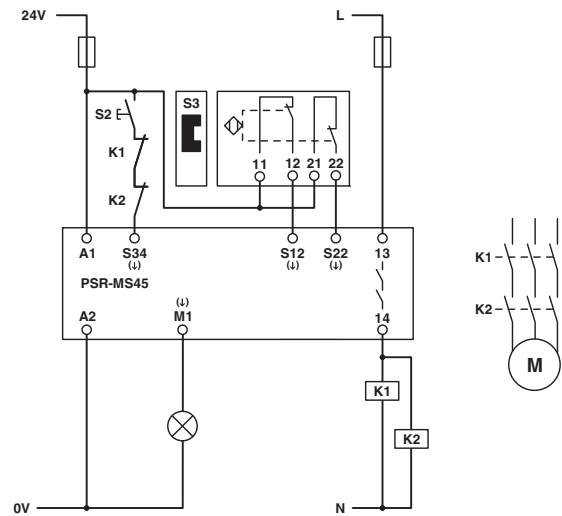

Figure 18 Magnetic switch monitoring/manual, monitored start

10 Applications with the PSR-MS50

Key:

- S1 = Emergency-stop button
- S3 = Magnetic switch
- K1/K2 = Contactors



Cross-circuits in the cable installation can be excluded if the safety relay and external contactors K1 and K2 are located in the same electrical installation space.

10.1 Magnetic switch monitoring/automatic start

- Two-channel, non-equivalent magnetic switch monitoring
- Automatic start
- Monitoring of external contactors
- Suitable up to category 4, PL e (EN ISO 13849-1), SIL 3 (EN 62061), if cross-circuits in the control to the actuator can be ruled out

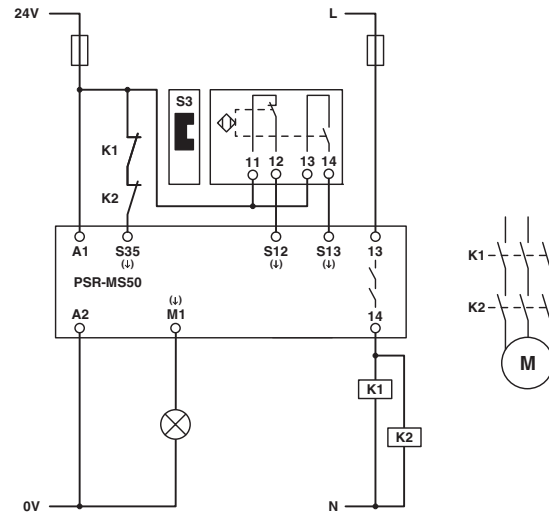

Figure 19 Magnetic switch monitoring/automatic start

11 Applications with the PSR-MS55

Key:

- S1 = Emergency-stop button
- S2 = Manual reset device
- S3 = Magnetic switch
- K1/K2 = Contactors



Cross-circuits in the cable installation can be excluded if the safety relay and external contactors K1 and K2 are located in the same electrical installation space.

11.1 Magnetic switch monitoring/manual, monitored start

- Two-channel, non-equivalent magnetic switch monitoring
- Manual, monitored start
- Monitoring of external contactors
- Suitable up to category 4, PL e (EN ISO 13849-1), SIL 3 (EN 62061), if cross-circuits in the control to the actuator can be ruled out

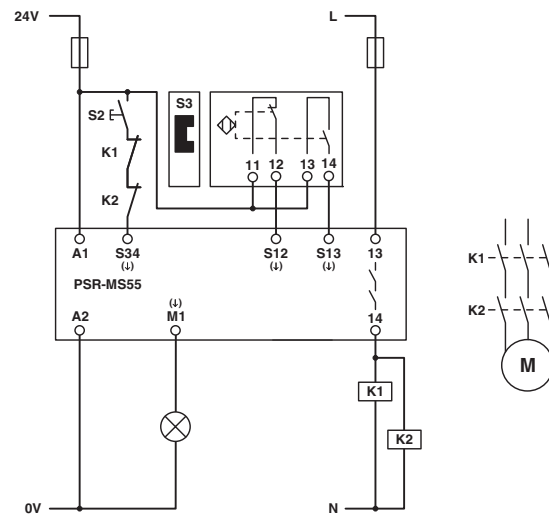

Figure 20 Magnetic switch monitoring/manual, monitored start

PSR-MS and PSR-MC

12 Applications with the PSR-MS60

Key:

K1/K2 = Contactors

12.1 Light grid monitoring/automatic start

- Two-channel light grid monitoring
- Automatic start
- Monitoring of external contactors
- Suitable up to category 4, PL e (EN ISO 13849-1), SIL 3 (EN 62061)



WARNING: Loss of functional safety!
 Make sure that the signal generator (e.g., PLC output card or light grid) and the safety relay have the same ground potential.

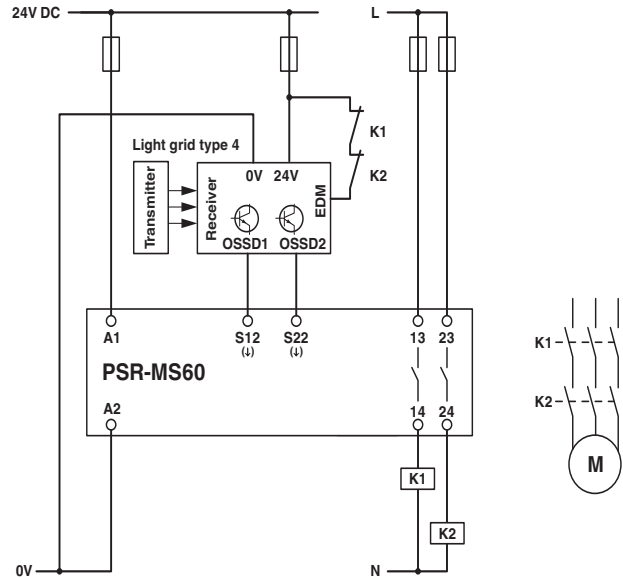

Figure 21 Light grid monitoring/automatic start

12.2 Two-channel control via LPSDO module

- Two-channel control
- Cross-circuit detection by means of LPSDO module
- Automatic start
- Monitoring of external contactors
- Suitable up to category 4, PL e (EN ISO 13849-1), SIL 3 (EN 62061)



WARNING: Loss of functional safety!
 Make sure that the signal generator (e.g., PLC output card or light grid) and the safety relay have the same ground potential.



The bright pulses (test pulses generated by switching on briefly) sent by the controller can lead to the brief, unwanted activation of the safety relay. You should therefore deactivate the bright pulses of the failsafe controller.

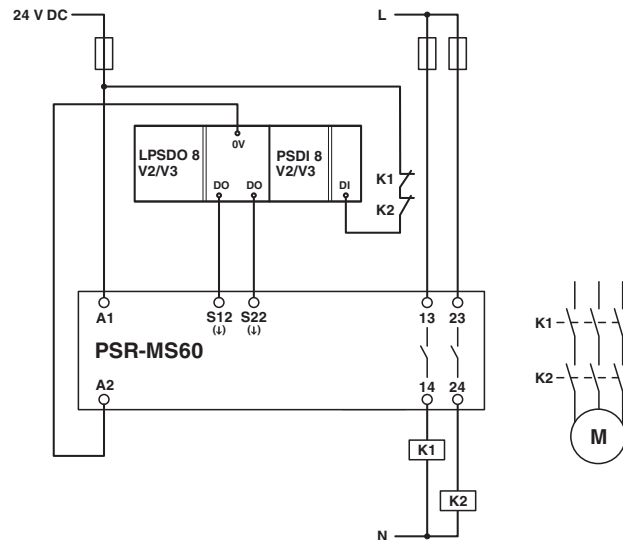

Figure 22 Two-channel control via LPSDO module

12.3 Single-channel control via failsafe controller

- Single-channel control
- Automatic start
- Monitoring of external contactors
- Suitable up to category 4, PL e (EN ISO 13849-1), SIL 3 (EN 62061), if the digital output of the safety-related controller meets PL e, SIL 3, and cross-circuits can be ruled out



WARNING: Loss of functional safety!

Make sure that the signal generator (e.g., PLC output card or light grid) and the safety relay have the same ground potential.

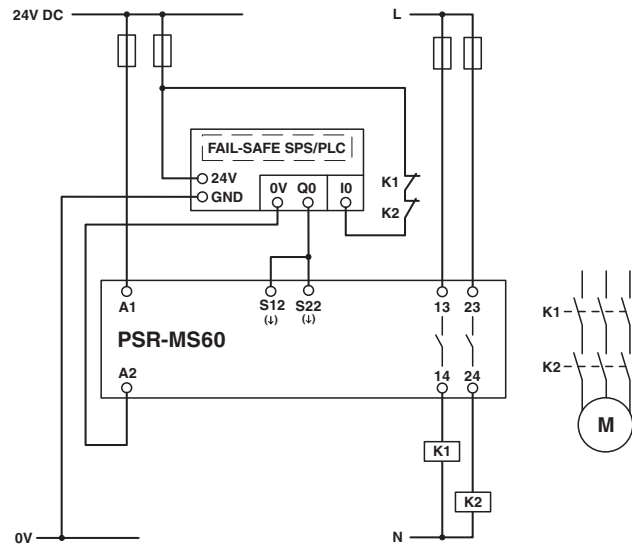

Figure 23 Single-channel control via failsafe PLC

PSR-MS and PSR-MC

13 Applications with the PSR-MC20

Key:

- S1 = Emergency-stop button
- S2 = Manual reset device
- B1/B2 = Mechanical safety door switches
- K1/K2 = Contactors

13.1 Emergency stop monitoring/automatic start

- Single-channel emergency stop monitoring
- Automatic start
- Monitoring of external contactors
- Suitable up to category 1, PL c (EN ISO 13849-1), SIL 1 (EN 62061)



Contactor K2 is not essential in order to achieve category 1.

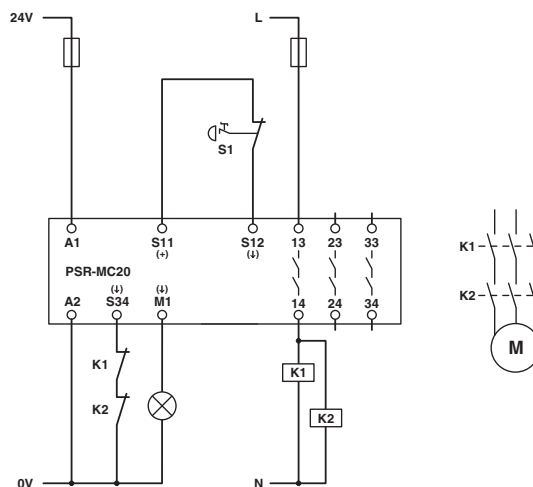

Figure 24 Emergency stop monitoring/automatic start

13.2 Emergency stop monitoring/manual, monitored start

- Single-channel emergency stop monitoring
- Manual, monitored start
- Monitoring of external contactors
- Suitable up to category 1, PL c (EN ISO 13849-1), SIL 1 (EN 62061)



Contactor K2 is not essential in order to achieve category 1.

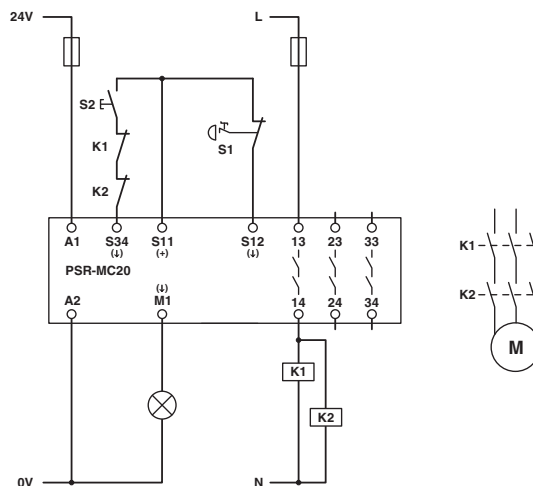

Figure 25 Emergency stop monitoring/manual, monitored start

13.3 Safety door monitoring/automatic start

- Single-channel safety door monitoring
- Automatic start
- Monitoring of external contactors
- Suitable up to category 1, PL c (EN ISO 13849-1), SIL 1 (EN 62061)

i Contactor K2 is not essential in order to achieve category 1.

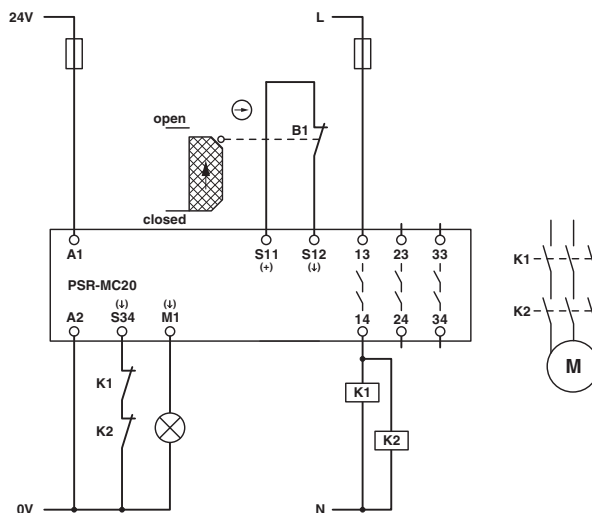

Figure 26 Safety door monitoring/automatic start

13.4 Safety door monitoring/manual, monitored start

- Single-channel safety door monitoring
- Manual, monitored start
- Monitoring of external contactors
- Suitable up to category 1, PL c (EN ISO 13849-1), SIL 1 (EN 62061)

i Contactor K2 is not essential in order to achieve category 1.

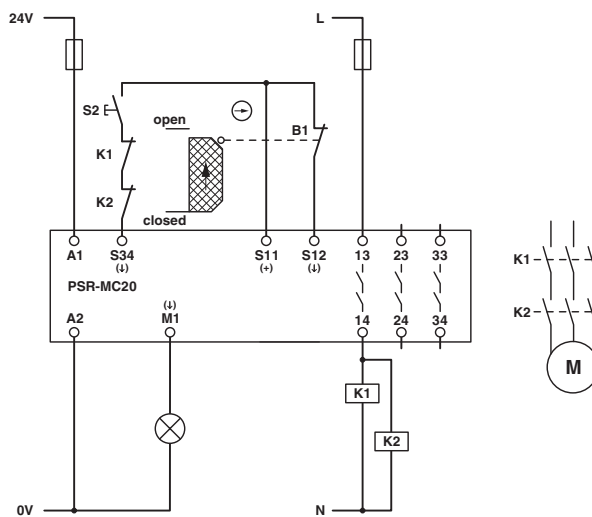

Figure 27 Safety door monitoring/manual, monitored start

PSR-MS and PSR-MC

13.5 Connection to failsafe controller/automatic start

- Automatic start
- Monitoring of external contactors
- Suitable up to category 4, PL e (EN ISO 13849-1), SIL 3 (EN 62061), if the digital output of the safety-related controller meets PL e, SIL 3, and cross-circuits can be ruled out



WARNING: Loss of functional safety!
 Make sure that the signal generator (e.g., PLC output card or light grid) and the safety relay have the same ground potential.



Cross-circuits in the cable installation can be excluded if the failsafe PLC, safety relay, and external contactors K1 and K2 are located in the same electrical installation space.

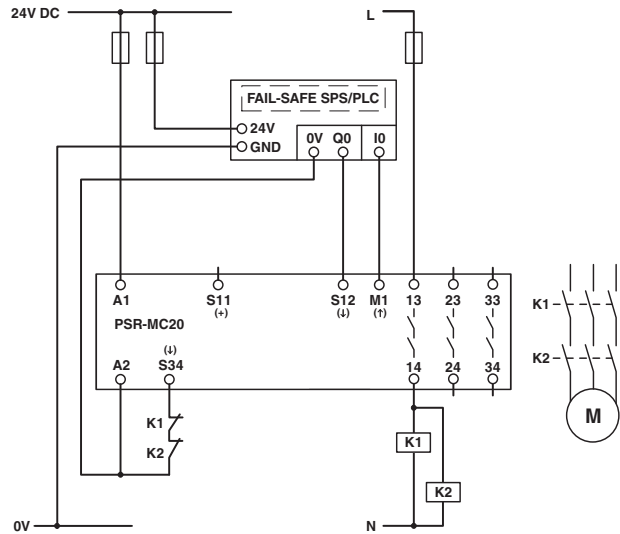

Figure 28 Connection to failsafe PLC/automatic start

14 Applications with the PSR-MC30

Key:

- S1 = Emergency-stop button
- S2 = Manual reset device
- S3 = Magnetic switch
- B1/B2 = Mechanical safety door switches
- K1/K2 = Contactors



Cross-circuits in the cable installation can be excluded if the safety relay and external contactors K1 and K2 are located in the same electrical installation space.

14.1 Emergency stop monitoring/automatic start

- Two-channel emergency stop monitoring
- Automatic start
- Monitoring of external contactors
- Suitable up to category 4, PL e (EN ISO 13849-1), SIL 3 (EN 62061), if cross-circuits in the control to the actuator can be ruled out

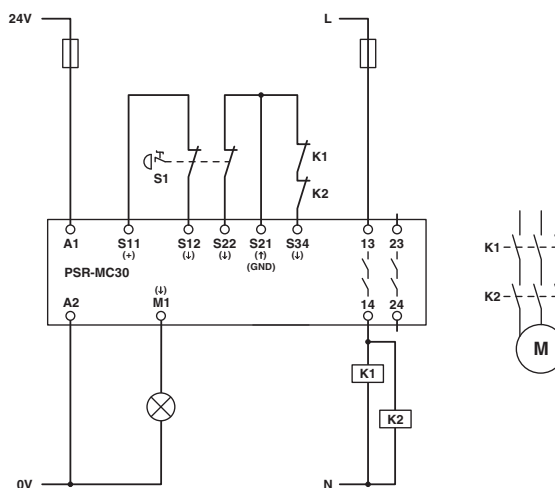

Figure 29 Emergency stop monitoring/automatic start

14.2 Emergency stop monitoring/manual, monitored start

- Two-channel emergency stop monitoring
- Manual, monitored start
- Monitoring of external contactors
- Suitable up to category 4, PL e (EN ISO 13849-1), SIL 3 (EN 62061), if cross-circuits in the control to the actuator can be ruled out

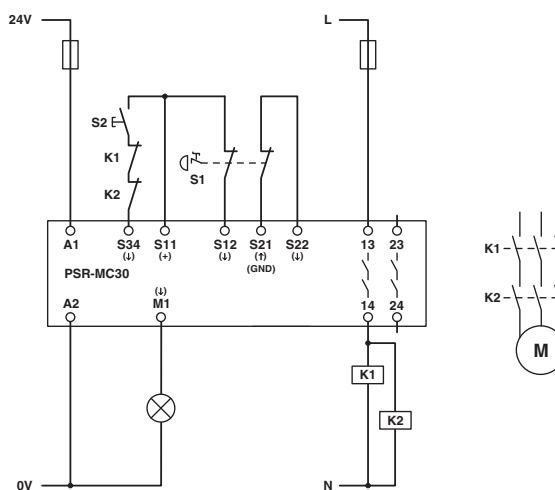

Figure 30 Emergency stop monitoring/manual, monitored start

PSR-MS and PSR-MC

14.3 Safety door monitoring/automatic start

- Two-channel safety door monitoring
- Automatic start
- Monitoring of external contactors
- Suitable up to category 4, PL e (EN ISO 13849-1), SIL 3 (EN 62061), if cross-circuits in the control to the actuator can be ruled out

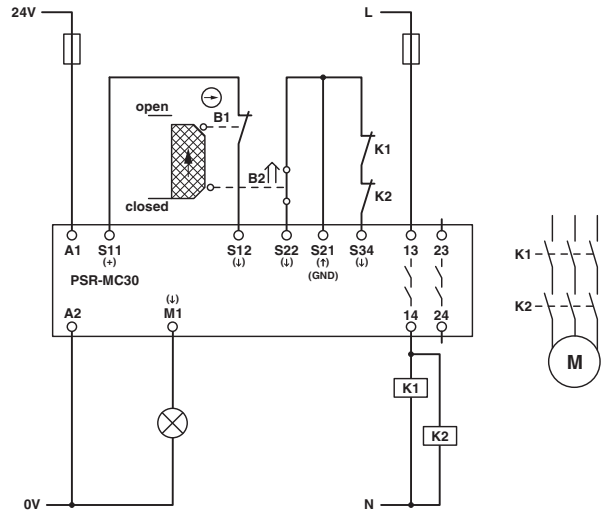

Figure 31 Safety door monitoring/automatic start

14.4 Safety door monitoring/automatic start/without cross-circuit detection

- Two-channel safety door monitoring
- Automatic start
- Monitoring of external contactors
- No cross-circuit detection in the sensor circuit
- Suitable up to category 4, PL e (EN ISO 13849-1), SIL 3 (EN 62061), if cross-circuits in the control to the actuator and the sensor circuit can be ruled out

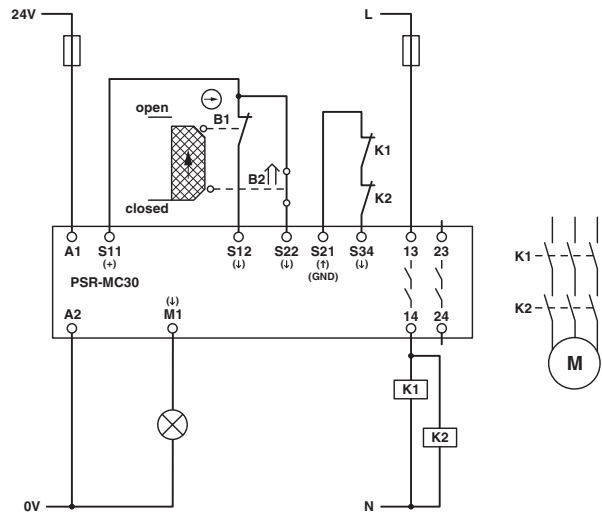



Figure 32 Safety door monitoring/automatic start/without cross-circuit detection

14.5 Single-channel safety door monitoring/automatic start

- Single-channel safety door monitoring
- Automatic start
- Monitoring of external contactors
- No cross-circuit detection in the sensor circuit
- Suitable up to category 1, PL c (EN ISO 13849-1), SIL 1 (EN 62061)

 Contactor K2 is not essential in order to achieve category 1.

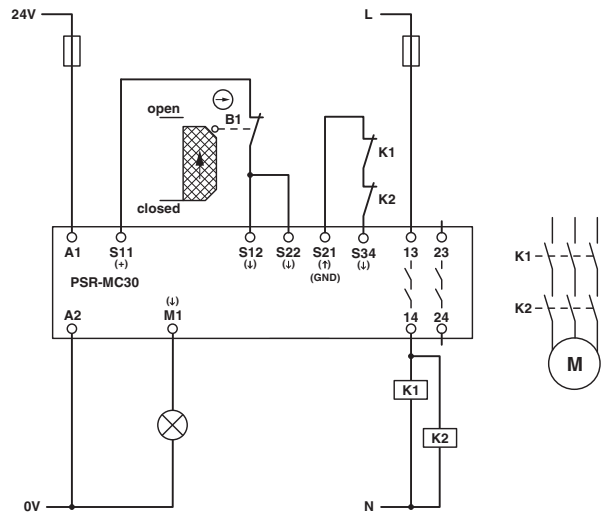

Figure 33 Single-channel safety door monitoring/automatic start

14.6 Safety door monitoring/manual, monitored start

- Two-channel safety door monitoring
- Manual, monitored start
- Monitoring of external contactors
- Suitable up to category 4, PL e (EN ISO 13849-1), SIL 3 (EN 62061), if cross-circuits in the control to the actuator can be ruled out

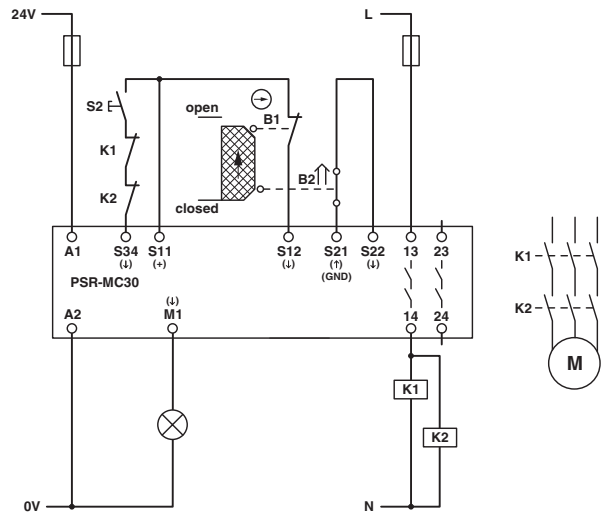

Figure 34 Safety door monitoring/manual, monitored start

PSR-MS and PSR-MC

14.7 Safety door monitoring/manual, monitored start/without cross-circuit detection

- Two-channel safety door monitoring
- Manual, monitored start
- Monitoring of external contactors
- No cross-circuit detection in the sensor circuit
- Suitable up to category 4, PL e (EN ISO 13849-1), SIL 3 (EN 62061), if cross-circuits in the control and the sensor circuit can be ruled out

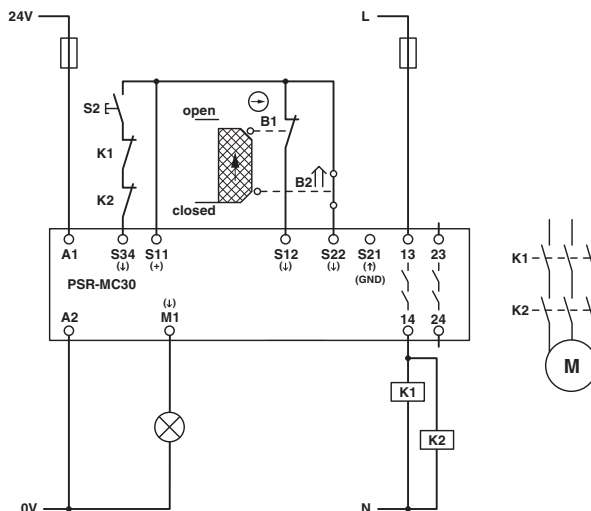

Figure 35 Safety door monitoring/manual, monitored start/without cross-circuit detection

14.8 Single-channel safety door monitoring/manual, monitored start

- Single-channel safety door monitoring
- Manual, monitored start
- Monitoring of external contactors
- No cross-circuit detection in the sensor circuit
- Suitable up to category 1, PL c (EN ISO 13849-1), SIL 1 (EN 62061)



Contactor K2 is not essential in order to achieve category 1.

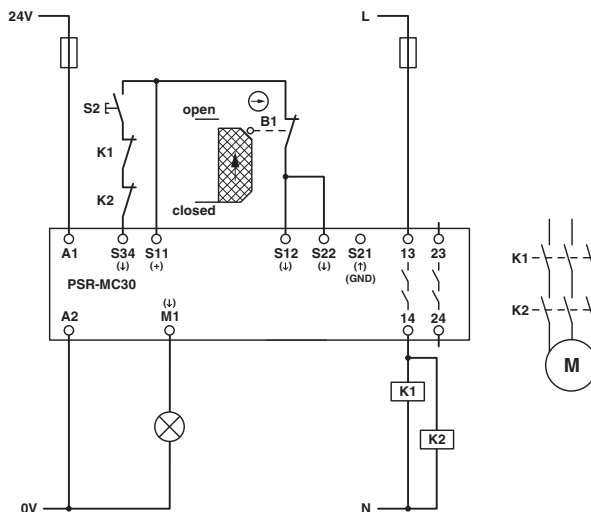

Figure 36 Single-channel safety door monitoring/manual, monitored start

14.9 Magnetic switch monitoring/automatic start

- Two-channel magnetic switch monitoring
- Automatic start
- Monitoring of external contactors
- Suitable up to category 4, PL e (EN ISO 13849-1), SIL 3 (EN 62061), if cross-circuits in the control to the actuator can be ruled out

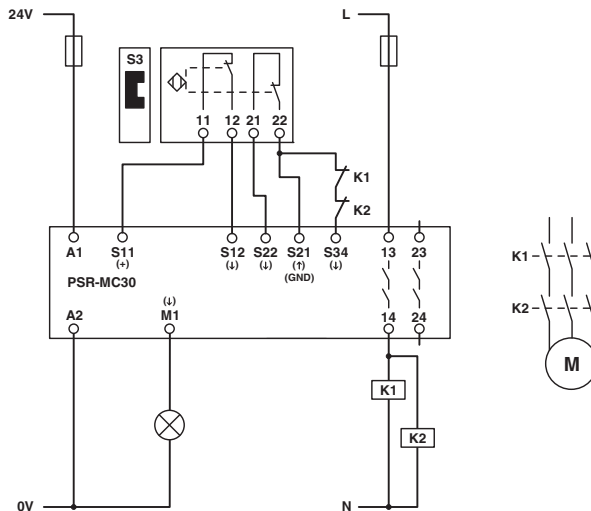

Figure 37 Magnetic switch monitoring/automatic start

14.10 Magnetic switch monitoring/manual, monitored start

- Two-channel magnetic switch monitoring
- Manual, monitored start
- Monitoring of external contactors
- Suitable up to category 4, PL e (EN ISO 13849-1), SIL 3 (EN 62061), if cross-circuits in the control to the actuator can be ruled out

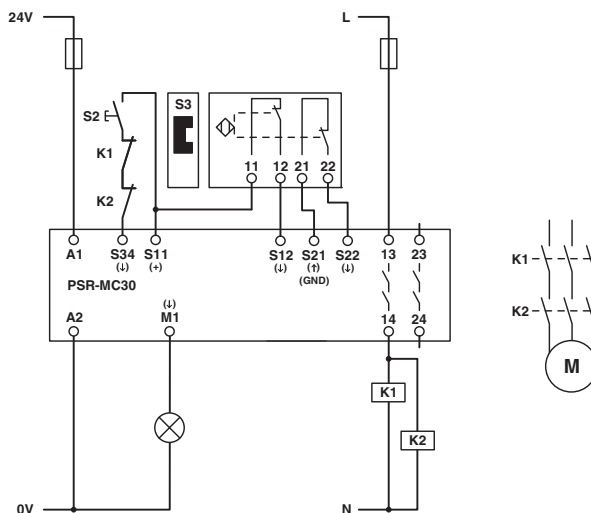

Figure 38 Magnetic switch monitoring/manual, monitored start

PSR-MS and PSR-MC

15 Applications with the PSR-MC34

Key:

- S1 = Emergency-stop button
- S2 = Manual reset device
- S3 = Magnetic switch
- B1/B2 = Mechanical safety door switches
- K1/K2 = Contactors



Cross-circuits in the cable installation can be excluded if the safety relay and external contactors K1 and K2 are located in the same electrical installation space.

15.1 Emergency stop monitoring/automatic start

- Two-channel emergency stop monitoring
- Automatic start
- Monitoring of external contactors
- Suitable up to category 4, PL e (EN ISO 13849-1), SIL 3 (EN 62061), if cross-circuits in the control to the actuator can be ruled out

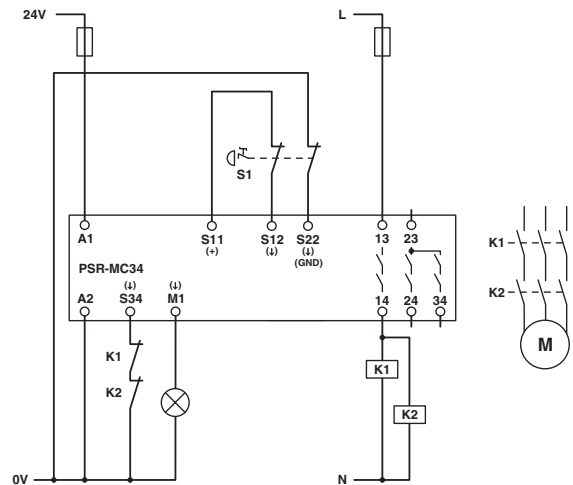

Figure 39 Emergency stop monitoring/automatic start

15.2 Emergency stop monitoring/manual, monitored start

- Two-channel emergency stop monitoring
- Manual, monitored start
- Monitoring of external contactors
- Suitable up to category 4, PL e (EN ISO 13849-1), SIL 3 (EN 62061), if cross-circuits in the control to the actuator can be ruled out

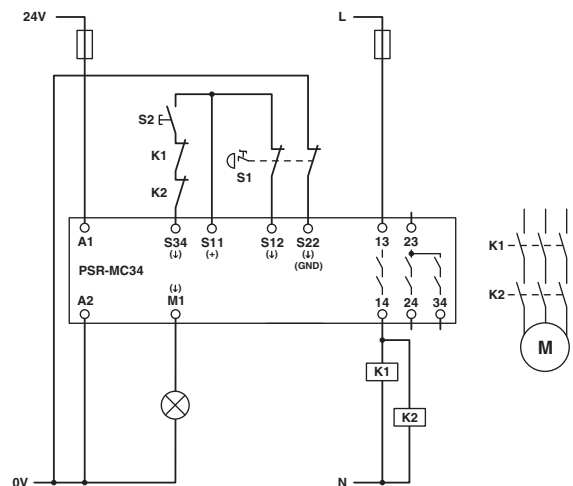

Figure 40 Emergency stop monitoring/manual, monitored start

15.3 Safety door monitoring/automatic start

- Two-channel safety door monitoring
- Automatic start
- Monitoring of external contactors
- Suitable up to category 4, PL e (EN ISO 13849-1), SIL 3 (EN 62061), if cross-circuits in the control to the actuator can be ruled out

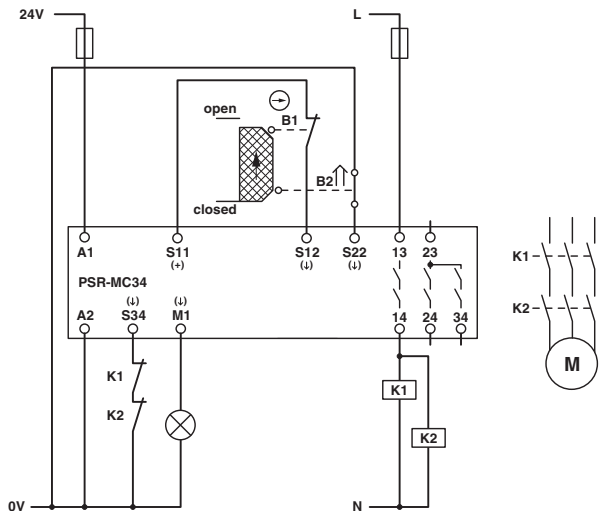

Figure 41 Safety door monitoring/automatic start

15.4 Safety door monitoring/automatic start/without cross-circuit detection

- Two-channel safety door monitoring
- Automatic start
- Monitoring of external contactors
- No cross-circuit detection in the sensor circuit
- Suitable up to category 4, PL e (EN ISO 13849-1), SIL 3 (EN 62061), if cross-circuits in the control to the actuator and the sensor circuit can be ruled out

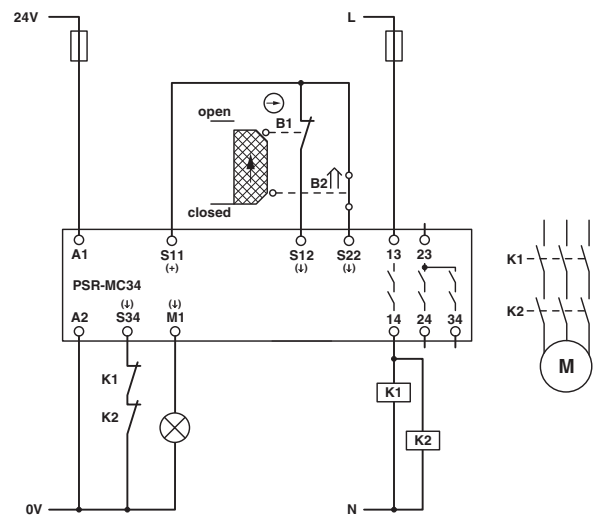

Figure 42 Safety door monitoring/automatic start/without cross-circuit detection

PSR-MS and PSR-MC

15.5 Single-channel safety door monitoring/automatic start

- Single-channel safety door monitoring
- Automatic start
- Monitoring of external contactors
- No cross-circuit detection in the sensor circuit
- Suitable up to category 1, PL c (EN ISO 13849-1), SIL 1 (EN 62061)

i Contactor K2 is not essential in order to achieve category 1.

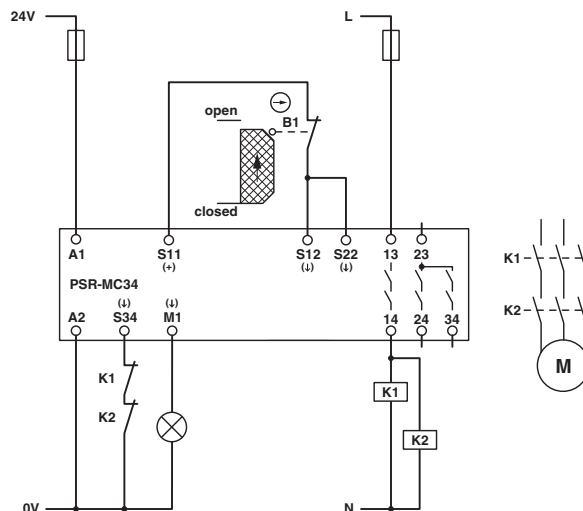

Figure 43 Single-channel safety door monitoring/automatic start

15.6 Safety door monitoring/manual, monitored start

- Two-channel safety door monitoring
- Manual, monitored start
- Monitoring of external contactors
- Suitable up to category 4, PL e (EN ISO 13849-1), SIL 3 (EN 62061), if cross-circuits in the control to the actuator can be ruled out

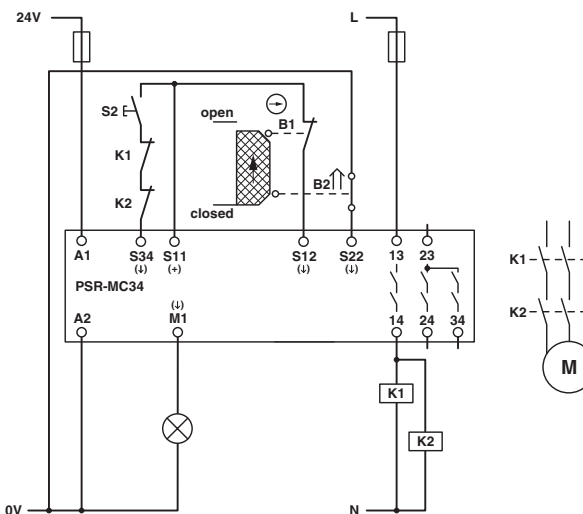

Figure 44 Safety door monitoring/manual, monitored start

PSR-MS and PSR-MC

15.9 Magnetic switch monitoring/automatic start

- Two-channel magnetic switch monitoring
- Automatic start
- Monitoring of external contactors
- Suitable up to category 4, PL e (EN ISO 13849-1), SIL 3 (EN 62061), if cross-circuits in the control to the actuator can be ruled out

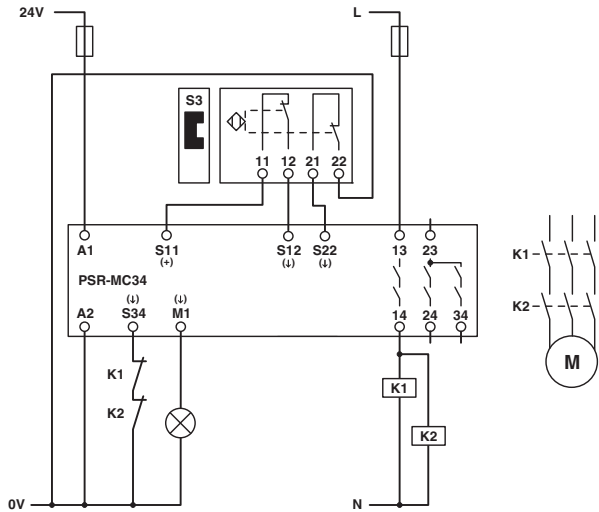

Figure 47 Magnetic switch monitoring/automatic start

15.10 Magnetic switch monitoring/manual, monitored start

- Two-channel magnetic switch monitoring
- Manual, monitored start
- Monitoring of external contactors
- Suitable up to category 4, PL e (EN ISO 13849-1), SIL 3 (EN 62061), if cross-circuits in the control to the actuator can be ruled out

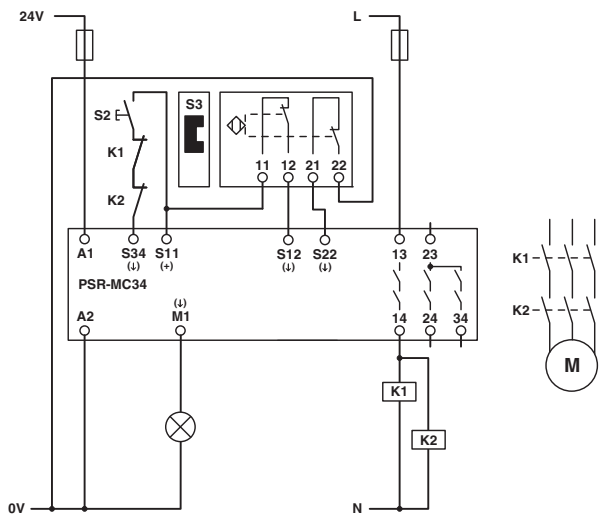

Figure 48 Magnetic switch monitoring/manual, monitored start

16 Applications with the PSR-MC40

Key:

- S1 = Emergency-stop button
- S2 = Manual reset device
- B1/B2 = Mechanical safety door switches
- K1/K2 = Contactors



Cross-circuits in the cable installation can be excluded if the safety relay and external contactors K1 and K2 are located in the same electrical installation space.

16.1 Emergency stop monitoring/automatic start

- Two-channel emergency stop monitoring
- Automatic start
- Monitoring of external contactors
- No cross-circuit detection in the sensor circuit
- Suitable up to category 4, PL e (EN ISO 13849-1), SIL 3 (EN 62061), if cross-circuits in the control to the actuator and the sensor circuit can be ruled out

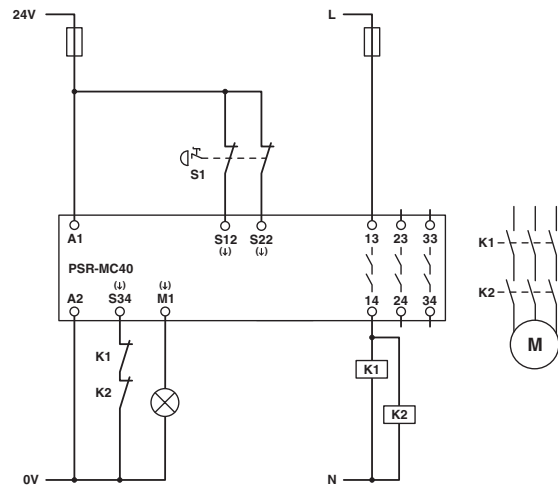

Figure 49 Emergency stop monitoring/automatic start

16.2 Emergency stop monitoring/manual, monitored start

- Two-channel emergency stop monitoring
- Manual, monitored start
- Monitoring of external contactors
- No cross-circuit detection in the sensor circuit
- Suitable up to category 4, PL e (EN ISO 13849-1), SIL 3 (EN 62061), if cross-circuits in the control to the actuator and the sensor circuit can be ruled out

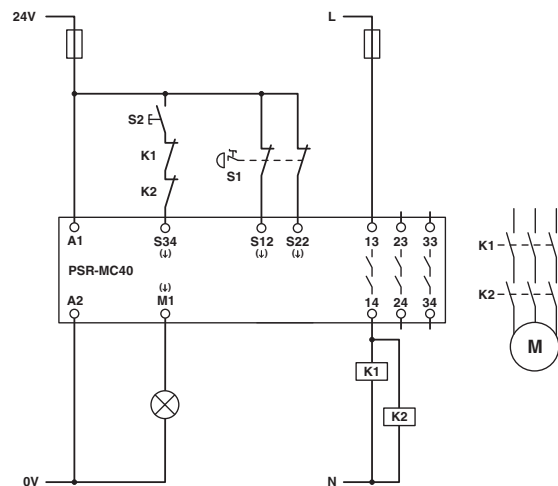

Figure 50 Emergency stop monitoring/manual, monitored start

16.5 Single-channel safety door monitoring/automatic start

- Single-channel safety door monitoring
- Automatic start
- Monitoring of external contactors
- No cross-circuit detection in the sensor circuit
- Suitable up to category 1, PL c (EN ISO 13849-1), SIL 1 (EN 62061)

i Contactor K2 is not essential in order to achieve category 1.

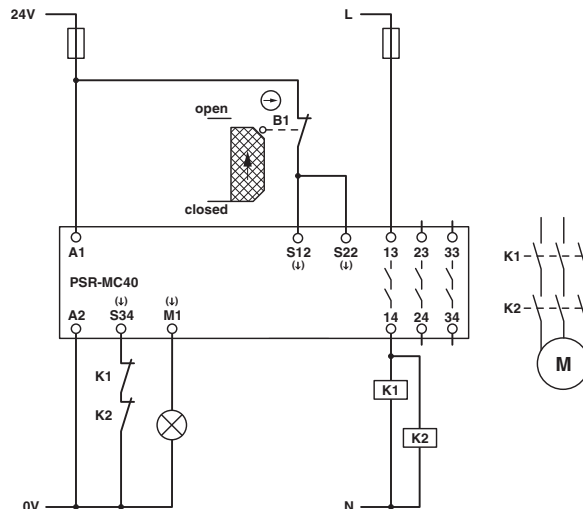

Figure 53 Single-channel safety door monitoring/automatic start

16.6 Single-channel safety door monitoring/manual, monitored start

- Single-channel safety door monitoring
- Manual, monitored start
- Monitoring of external contactors
- No cross-circuit detection in the sensor circuit
- Suitable up to category 1, PL c (EN ISO 13849-1), SIL 1 (EN 62061)

i Contactor K2 is not essential in order to achieve category 1.

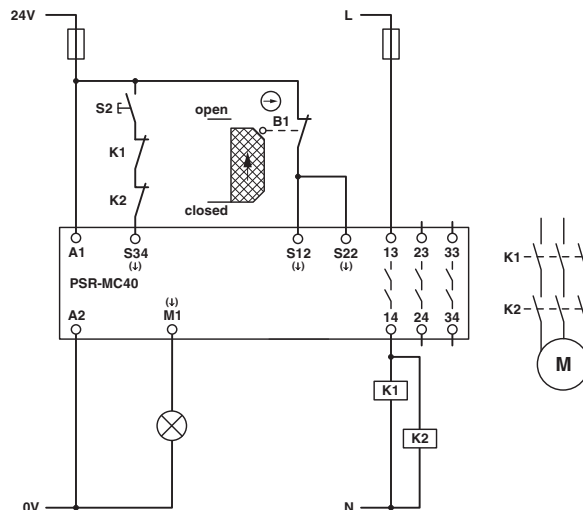

Figure 54 Single-channel safety door monitoring/manual, monitored start

PSR-MS and PSR-MC

16.7 Connection to failsafe controller/automatic start

- Two-channel connection to the failsafe PLC
- Automatic start
- Monitoring of external contactors
- No cross-circuit detection in the sensor circuit
- Suitable up to category 4, PL e (EN ISO 13849-1), SIL 3 (EN 62061), if the two-channel digital output of the safety-related controller meets PL e, SIL 3



WARNING: Loss of functional safety!
 Make sure that the signal generator (e.g., PLC output card or light grid) and the safety relay have the same ground potential.

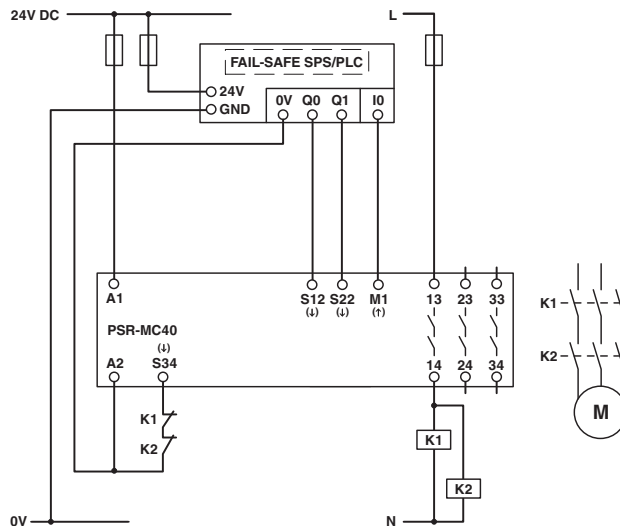

Figure 55 Connection to failsafe PLC/automatic start

16.8 Connection to failsafe controller/manual, monitored start

- Two-channel connection to the failsafe PLC
- Manual, monitored start
- Monitoring of external contactors
- No cross-circuit detection in the sensor circuit
- Suitable up to category 4, PL e (EN ISO 13849-1), SIL 3 (EN 62061), if the two-channel digital output of the safety-related controller meets PL e, SIL 3



WARNING: Loss of functional safety!
 Make sure that the signal generator (e.g., PLC output card or light grid) and the safety relay have the same ground potential.

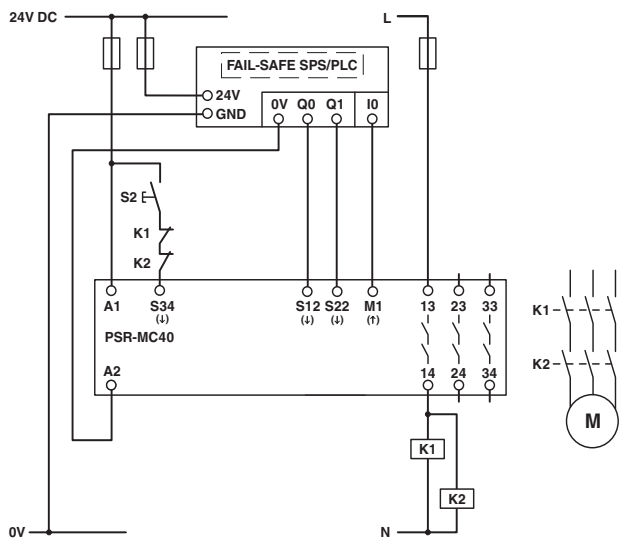

Figure 56 Connection to failsafe PLC/manual, monitored start

16.9 Single-channel connection to failsafe controller/automatic start

- Single-channel connection to the failsafe PLC
- Automatic start
- Monitoring of external contactors
- No cross-circuit detection in the sensor circuit
- Suitable up to category 4, PL e (EN ISO 13849-1), SIL 3 (EN 62061), if the digital output of the safety-related controller meets PL e, SIL 3, and cross-circuits can be ruled out



WARNING: Loss of functional safety!
 Make sure that the signal generator (e.g., PLC output card or light grid) and the safety relay have the same ground potential.



Cross-circuits in the cable installation can be excluded if the failsafe PLC, safety relay, and external contactors K1 and K2 are located in the same electrical installation space.

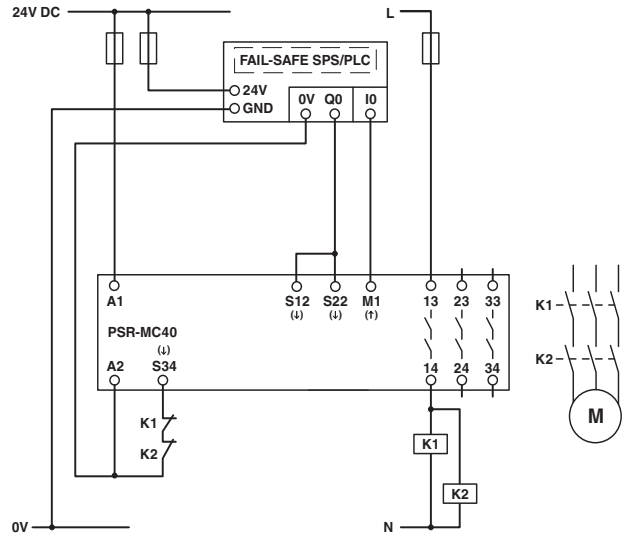

Figure 57 Single-channel connection to failsafe PLC/automatic start

16.10 Single-channel connection to failsafe controller/manual, monitored start

- Single-channel connection to the failsafe PLC
- Manual, monitored start
- Monitoring of external contactors
- No cross-circuit detection in the sensor circuit
- Suitable up to category 4, PL e (EN ISO 13849-1), SIL 3 (EN 62061), if the digital output of the safety-related controller meets PL e, SIL 3, and cross-circuits can be ruled out



WARNING: Loss of functional safety!
 Make sure that the signal generator (e.g., PLC output card or light grid) and the safety relay have the same ground potential.



Cross-circuits in the cable installation can be excluded if the failsafe PLC, safety relay, and external contactors K1 and K2 are located in the same electrical installation space.

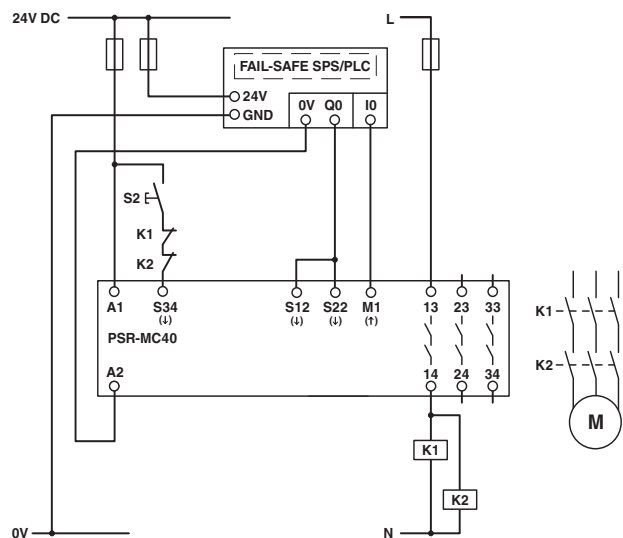

Figure 58 Single-channel connection to failsafe PLC/manual, monitored start

PSR-MS and PSR-MC

16.11 Light grid monitoring/automatic start

- Two-channel light grid monitoring
- Automatic start
- Monitoring of external contactors
- No cross-circuit detection in the sensor circuit
- Suitable up to category 4, PL e (EN ISO 13849-1), SIL 3 (EN 62061), if cross-circuits in the control to the actuator can be ruled out



WARNING: Loss of functional safety!
 Make sure that the signal generator (e.g., PLC output card or light grid) and the safety relay have the same ground potential.

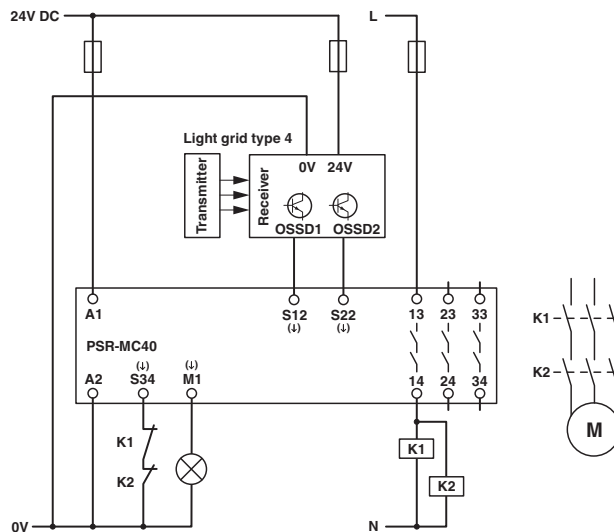

Figure 59 Light grid monitoring/automatic start

16.12 Light grid monitoring/manual, monitored start

- Two-channel light grid monitoring
- Manual, monitored start
- Monitoring of external contactors
- No cross-circuit detection in the sensor circuit
- Suitable up to category 4, PL e (EN ISO 13849-1), SIL 3 (EN 62061), if cross-circuits in the control to the actuator can be ruled out



WARNING: Loss of functional safety!
 Make sure that the signal generator (e.g., PLC output card or light grid) and the safety relay have the same ground potential.

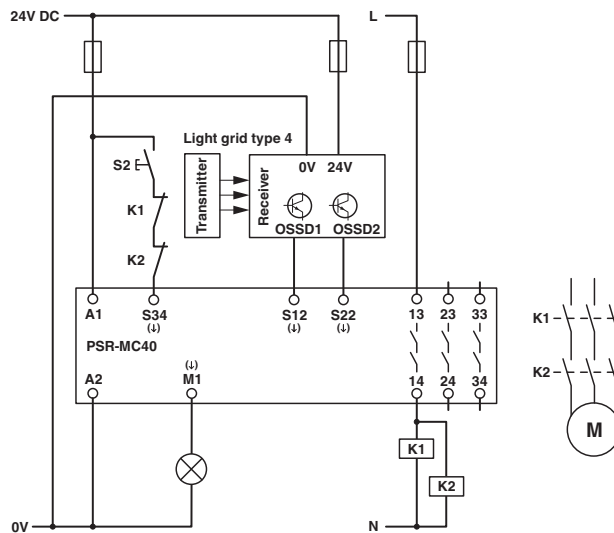

Figure 60 Light grid monitoring/manual, monitored start

16.13 Transponder monitoring/automatic start

- Two-channel transponder monitoring
- Automatic start
- Monitoring of external contactors
- No cross-circuit detection in the sensor circuit
- Suitable up to category 4, PL e (EN ISO 13849-1), SIL 3 (EN 62061), if cross-circuits in the control to the actuator can be ruled out



WARNING: Loss of functional safety!
 Make sure that the signal generator (e.g., PLC output card or light grid) and the safety relay have the same ground potential.

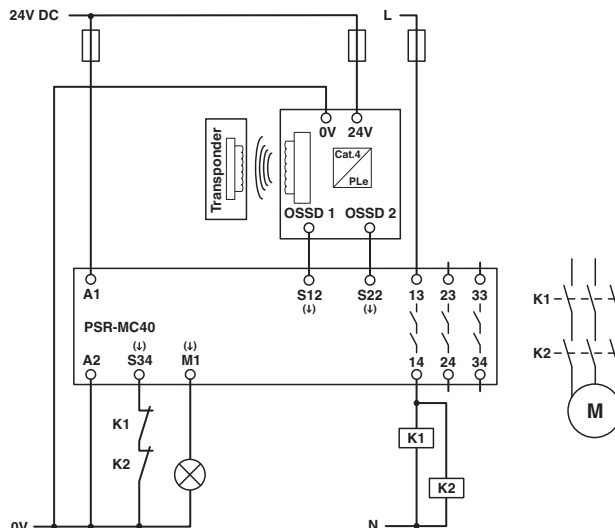

Figure 61 Transponder monitoring/automatic start

16.14 Transponder monitoring/manual, monitored start

- Two-channel transponder monitoring
- Manual, monitored start
- Monitoring of external contactors
- No cross-circuit detection in the sensor circuit
- Suitable up to category 4, PL e (EN ISO 13849-1), SIL 3 (EN 62061), if cross-circuits in the control to the actuator can be ruled out



WARNING: Loss of functional safety!
 Make sure that the signal generator (e.g., PLC output card or light grid) and the safety relay have the same ground potential.

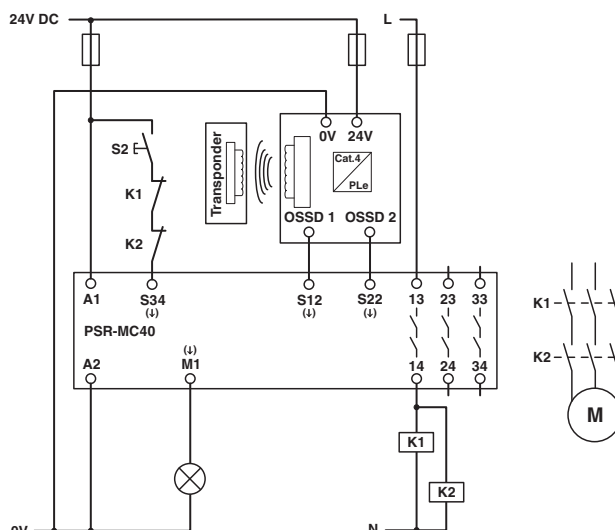

Figure 62 Transponder monitoring/manual, monitored start

17 Applications with the PSR-MC50

Key:

- S1 = Emergency-stop button
- S2 = Manual reset device
- S3 = Magnetic switch
- K1/K2 = Contactors



Cross-circuits in the cable installation can be excluded if the safety relay and external contactors K1 and K2 are located in the same electrical installation space.

17.1 Magnetic switch monitoring/automatic start

- Two-channel, non-equivalent magnetic switch monitoring
- Automatic start
- Monitoring of external contactors
- Suitable up to category 4, PL e (EN ISO 13849-1), SIL 3 (EN 62061), if cross-circuits in the control to the actuator can be ruled out

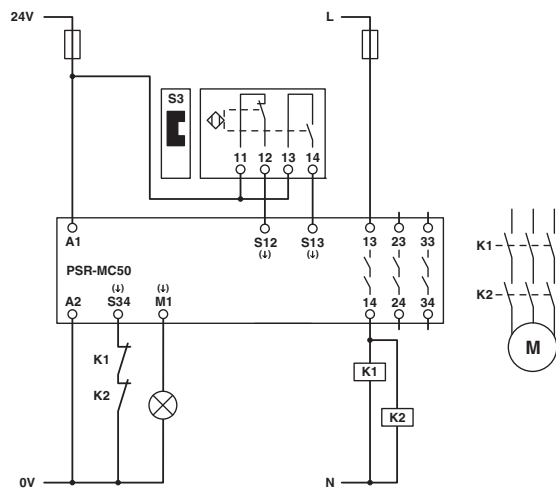

Figure 63 Magnetic switch monitoring/automatic start

17.2 Magnetic switch monitoring/manual, monitored start

- Two-channel, non-equivalent magnetic switch monitoring
- Manual, monitored start
- Monitoring of external contactors
- Suitable up to category 4, PL e (EN ISO 13849-1), SIL 3 (EN 62061), if cross-circuits in the control to the actuator can be ruled out

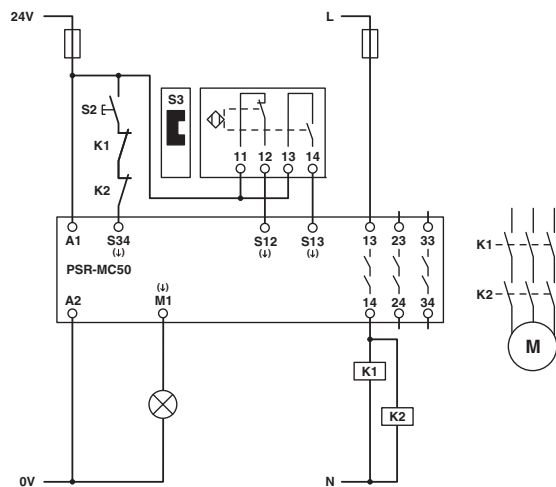

Figure 64 Magnetic switch monitoring/manual, monitored start

17.3 Safety door monitoring/automatic start

- Non-equivalent safety door monitoring
- Automatic start
- Monitoring of external contactors
- Suitable up to category 1, PL c (EN ISO 13849-1), SIL 1 (EN 62061)
- Suitable up to category 4, PL e (EN ISO 13849-1), SIL 3 (EN 62061), if cross-circuits in the control to the actuator can be ruled out and two switches of Type 1 are used

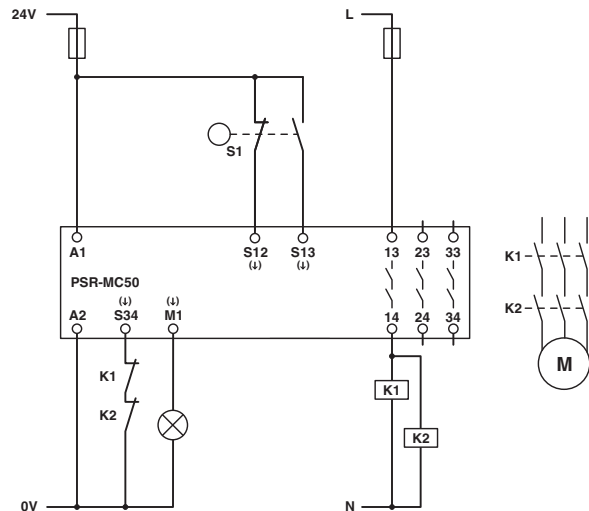

Figure 65 Safety door monitoring/automatic start

17.4 Safety door monitoring/manual, monitored start

- Non-equivalent safety door monitoring
- Manual, monitored start
- Monitoring of external contactors
- Suitable up to category 1, PL c (EN ISO 13849-1), SIL 1 (EN 62061)
- Suitable up to category 4, PL e (EN ISO 13849-1), SIL 3 (EN 62061), if cross-circuits in the control to the actuator can be ruled out and two switches of Type 1 are used

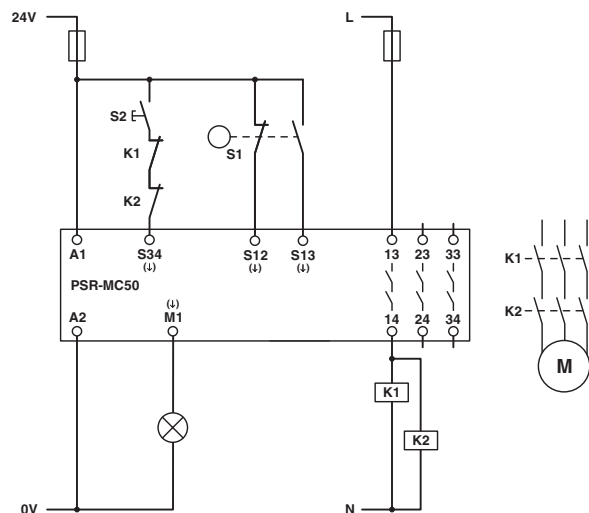

Figure 66 Safety door monitoring/manual, monitored start

18 Revision history

Revision	Date	Content
00	2015-01-14	First publication
01	2015-08-27	Ordering data changed: Article number 2992239 replaced by material number 52007563 Application examples revised: 4.3, 5.3, 12.1, 12.2, 12.3, 13.5, 16.7, 16.8, 16.9, 16.10, 16.11, 16.12, 16.13, 16.14 Infobox inserted for all application examples up to Cat. 1



SCATTERGOOD & JOHNSON LTD

ELECTRICAL ENGINEERING & FLUID CONTROL DISTRIBUTORS

Est.1899

At Scattergood & Johnson Ltd, we pride ourselves on being a technical distributor to specialist industries.

Working with a range of quality product suppliers across a number of specialist markets, we are not your average 'box shifter' - we are your technical and supply chain partner.

We fully support every product we sell - for free! Our internal team and external sales engineers can answer any product or application question, no matter the complexity.

Backing up this technical ability is a range of 50,000+ products available from stock for nationwide next day delivery (same day if required!), or you can collect what you need from any of our trade counters around the UK.

Select your specialist interest below to learn more about how we can help.



Online, In Branch and On the Road - Scattergood & Johnson Ltd, there when you need us.

www.scatts.co.uk