

PSR-MC40

Safety relay for emergency stop, safety door and light grid monitoring

Data sheet
106175_en_03

© PHOENIX CONTACT 2016-10-21

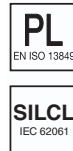

1 Description

Intended Use

The safety relay is used to monitor single or two-channel signal generators and to control actuators.

When the sensor circuit is interrupted, the safety relay initiates the safe state.

The safety relay interrupts circuits in a safety-related way.

Possible signal generators

- Emergency stop button
- Door locking mechanisms
- Light grids

Contact type

- 3 undelayed enabling current paths
- 1 digital signal output

The enabling current paths drop out without delay according to stop category 0 (EN 60204-1).

When the enabling current paths are open, the signal output is active.

The signal output transmits non-safety-related status information.

Control

- Single or two channel
- Automatic or manual, monitored start

Achievable safety integrity

- Suitable up to category 4, PL e (EN ISO 13849-1), SILCL 3 (EN 62061)

Additional features

- Option of screw or spring-cage terminal blocks for plug-in
- 12.5 mm housing width

Approvals



WARNING: Risk of electric shock

Observe the safety regulations and installation notes in the corresponding section.



Make sure you always use the latest documentation.

It can be downloaded from the product at phoenixcontact.net/products.



This document is valid for the products listed in the "Ordering data".

This document meets the same requirements as the original operating instructions with respect to the contents.

2	Table of contents	
1	Description	1
2	Table of contents	2
3	Ordering data	3
4	Technical data	3
5	Safety regulations and installation notes.....	7
6	Function description	8
7	Function and time diagrams	8
8	Basic circuit diagram	9
9	Derating.....	9
10	Load curve.....	9
11	Operating and indication elements	10
12	Mounting and removing	11
13	Wiring	11
14	Startup.....	12
15	Calculating the power dissipation	12
16	Diagnostics.....	13
17	Application examples	15
18	Attachment	28

3 Ordering data

Description	Type	Order No.	Pcs./Pkt.
Safety relay for emergency stop, safety doors, and light grids up to SILCL 3, Cat. 4, PL e, 1 or 2-channel operation, automatic or manual, monitored start, 3 enabling current paths, $U_S = 24$ V DC, plug-in screw terminal block	PSR-MC40-3NO-1DO-24DC-SC	2700569	1
Safety relay for emergency stop, safety doors, and light grids up to SILCL 3, Cat. 4, PL e, 1 or 2-channel operation, automatic or manual, monitored start, 3 enabling current paths, $U_S = 24$ V DC, plug-in spring-cage terminal block	PSR-MC40-3NO-1DO-24DC-SP	2700570	1

4 Technical data

Hardware/firmware version	
HW/FW	≥ 00/--
The technical data and safety characteristics are valid as of the specified HW/FW version.	
Input data	
Rated control circuit supply voltage U_S	24 V DC -15 % / +10 %
Rated control supply current I_S	typ. 80 mA
Input voltage range "0" signal	0 V DC ... 5 V DC (for safe Off; at S12 and S22)
Input current range "0" signal	0 mA ... 2 mA (for safe Off; at S12 and S22)
Inrush current	5 A ($\Delta t = 200 \mu s$ at U_S) < 20 mA (with U_S/I_x to S12) < 200 mA (with U_S/I_x to S34) < 5 mA (with U_S/I_x to S22)
Current consumption	< 5 mA (with U_S/I_x to S12) < 5 mA (with U_S/I_x to S22) > -5 mA (with U_S/I_x to S34) < 10 mA (with U_S/I_x to S34)
Power consumption at U_S	typ. 1.92 W
Voltage at input/start and feedback circuit	24 V DC -15 % / +10 %
Filter time	1 ms (at A1 in the event of voltage dips at U_S) max. 1.5 ms (at S12, S22; test pulse width) min. 7.5 ms (at S12, S22; test pulse rate) Test pulse rate = 5 x Test pulse width
Max. permissible overall conductor resistance (Input and reset circuit at U_S)	150 Ω
Typical response time at U_S	< 175 ms (automatic start) < 175 ms (manual, monitored start)
Typical starting time with U_S	< 250 ms (when controlled via A1)
Typical release time with U_S	< 20 ms (when controlled via A1 or S12 and S22.)
Recovery time	< 500 ms
Maximum switching frequency	0.5 Hz

Input data	
Operating voltage display	1 x green LED
Status display	3 x green LED
Protective circuit	Surge protection Suppressor diode Protection against polarity reversal for rated control circuit supply voltage
Output data	
Contact type	3 enabling current paths
Contact material	AgSnO ₂
Minimum switching voltage	12 V AC/DC
Maximum switching voltage	250 V AC/DC (Observe the load curve)
Limiting continuous current	6 A (observe derating)
Maximum inrush current	6 A
Inrush current, minimum	3 mA
Sq. Total current $I_{TH}^2 = I_1^2 + I_2^2 + \dots + I_N^2$	48 A ² (observe derating)
Switching capacity	min. 60 mW
Mechanical service life	10 x 10 ⁶ cycles
Output fuse	6 A gL/gG (N/O contact) 4 A gL/gG (for low-demand applications)
Alarm outputs	
Number of outputs	1 (digital, PNP)
Voltage	22 V DC (U _s - 2 V)
Current	max. 100 mA
Maximum inrush current	500 mA (Δt = 1 ms at U _s)
Short-circuit protection	no
General data	
Relay type	Electromechanical relay with forcibly guided contacts in accordance with IEC/EN 61810-3 (EN 50205)
Nominal operating mode	100% operating factor
Degree of protection	IP20
Min. degree of protection of inst. location	IP54
Mounting type	DIN rail mounting
Mounting position	vertical or horizontal
Assembly instructions	See derating curve
Type of housing	PBT yellow
Air clearances and creepage distances between the power circuits	according to DIN EN 50178
Rated insulation voltage	250 V AC

General data		
Rated surge voltage/insulation	Safe isolation, reinforced insulation 6 kV between input circuit and enabling current path (13/14) and enabling current path (23/24) and enabling current path (33/34) Basic insulation 4 kV between all current paths and housing	
Degree of pollution	2	
Overtoltage category	III	
Dimensions	Screw connection	Spring-cage connection
W x H x D	12.5 x 112.2 x 114.5 mm	12.5 x 116.6 x 114.5 mm
Connection data	Screw connection	Spring-cage connection
Conductor cross section, solid	0.2 mm ² ... 2.5 mm ²	0.2 mm ² ... 1.5 mm ²
Conductor cross section, flexible	0.2 mm ² ... 2.5 mm ²	0.2 mm ² ... 1.5 mm ²
Conductor cross section AWG/kcmil	24 ... 12	24 ... 16
Stripping length	7 mm	8 mm
Screw thread	M3	
Ambient conditions		
Ambient temperature (operation)	-40 °C ... 55 °C (observe derating)	
Ambient temperature (storage/transport)	-40 °C ... 85 °C	
Max. permissible relative humidity (operation)	75 % (on average, 85% infrequently, non-condensing)	
Max. permissible humidity (storage/transport)	75 % (on average, 85% infrequently, non-condensing)	
Maximum altitude	≤ 2000 m (Above sea level)	
Information on operating height	See the "Using PSR devices at altitudes greater than 2000 m above sea level" section	
Shock	15g	
Vibration (operation)	10 Hz ... 150 Hz, 2g	
Conformance/Approvals		
Conformance	CE-compliant	
The full EC Declaration of Conformity can be downloaded for the product at phoenixcontact.net/products .		
Approvals		
Safety data		
Stop category according to IEC 60204	0	
Safety parameters for IEC 61508 - High demand		
SIL	3	
PFH _D	1.5 x 10 ⁻⁹ (4 A DC13; 5 A AC15; 8760 switching cycles/year)	
Demand rate	< 12 Months	
Proof test interval	240 Months	
Duration of use	240 Months	

Safety parameters for IEC 61508 - Low demand

SIL	3
PFD _{avg}	1,46 x 10 ⁻⁴
Proof test interval	60 Months
Duration of use	240 Months

Safety characteristic data according to EN ISO 13849

Category	4
Performance level	e (4 A DC13; 5 A AC15; 8760 switching cycles/year)
Duration of use	240 Months

For applications in PL e, the required demand rate for the safety function is once per month.

Safety parameters for EN 62061

SILCL	3
-------	---

5 Safety regulations and installation notes



WARNING: Death, serious personal injury or damage to equipment

Depending on the application, incorrect handling of the device may pose serious risks for the user or cause damage to equipment.

- Observe all the safety notes and warning instructions provided in this chapter and elsewhere in this document.

General

- Observe the safety regulations of electrical engineering and industrial safety and liability associations.

Disregarding these safety regulations may result in death, serious personal injury or damage to equipment.

Power supply units for 24 V supply

- Only use power supply units with safe isolation and SELV/PELV according to EN 50178/VDE 0160.
- Provide external protection for the 24 V area.
- Make sure that the power supply unit is able to supply **four times** the nominal current of the external fuse, to ensure that it trips in the event of an error.

Startup, mounting, and modifications

Startup, mounting, modifications, and upgrades may only be carried out by an electrically skilled person.

- Before working on the device, disconnect the power.
- Carry out wiring according to the application. Refer to the “Application examples” section for this.

Reliable operation is only ensured if the device is installed in housing protected from dust and humidity.

- Install the device in housing protected from dust and humidity (min. IP54).

In operation

During operation, parts of electrical switching devices carry hazardous voltages.

- Protective covers must not be removed when operating electrical switching devices.

For emergency stop applications, automatic startup of the machine can pose serious risks for the user.

- The machine must be prevented from restarting automatically by a higher-level controller.

With the manual, monitored reset device, a machine start may not be triggered in accordance with EN ISO 13849-1.

Inductive loads can lead to welded relay contacts.

- Connect a suitable and effective protective circuit to inductive loads.
- Implement the protective circuit parallel to the load and not parallel to the switch contact.

Magnetic fields can influence the device. The magnetic field strength of the environment must not exceed 30 A/m.

- Do not use the device in the vicinity of strong magnetic fields (e.g., caused by transformers or magnetic iron).

Noise emission may occur when operating relay modules. Wireless reception may be disrupted in residential areas.

The device is a Class A product.

- Observe the requirements for noise emission for electrical and electronic equipment (EN 61000-6-4).
- Implement appropriate precautions against noise emission.

Faulty devices

The devices may be damaged following an error. Correct operation can no longer be ensured.

- In the event of an error, replace the device.

Only the manufacturer or their authorized representative may perform the following activities. Otherwise the warranty is invalidated.

- Repairs to the device
- Opening the housing

Taking out of service and disposal

- Dispose of the device in accordance with environmental regulations.
- Make sure that the device can never be reused.

6 Function description

6.1 Single-channel sensor circuit

The sensor circuit is not designed with redundancy.

The safety relay does not detect short and cross-circuits in the sensor circuit.

6.2 Two-channel sensor circuit

The sensor circuit is designed with redundancy.

The safety relay does not detect short and cross-circuits in the sensor circuit.

External cross-circuit detection can be implemented by using a suitable signal generator.

6.3 Automatic start

The device starts automatically after the sensor circuit has been closed.

6.4 Manual, monitored start

When the sensor circuit is closed, the device starts once the start circuit has been closed and opened again by pressing and releasing the reset button.

A connected reset button is monitored.



WARNING: Risk of automatic machine restart!

If the manual reset function with monitored start is used, a cross-circuit between A2 (0 V) and the cable from the reset button to S34 can result in automatic machine startup.

This applies in particular for safety functions with increased risk potential.

- Prevent a cross-circuit between A2 (0 V) and the cable from the reset button to S34 by means of design measures (see error prevention in accordance with EN ISO 13849-2).

6.5 Safe shutdown

When the sensor circuit opens, the enabling current paths open without delay.

When the enabling current paths are open, the device is in the safe state.

Signal output M1 is active.



Signal output M1 transmits non-safety-related status information. Feedback of signal output M1 to external basic devices for reasons of functional safety is therefore not required.

7 Function and time diagrams

7.1 Time diagram for automatic start

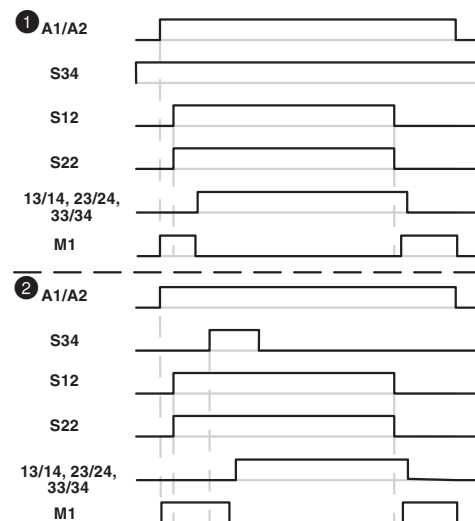

Figure 1 Time diagram for automatic start

7.2 Time diagram for manual, monitored start



Figure 2 Time diagram for manual, monitored start

Key:

- ① Automatic start
- ② Start via external signal at S34 which is not monitored
- A1/A2 Power supply
- S34 Start circuit
- S12 Input sensor circuit (channel 1)
- S22 Input sensor circuit (channel 2)
- 13/14, 23/24, 33/34 Undelayed enabling current paths
- M1 Signal output (PNP), not security-relevant

8 Basic circuit diagram

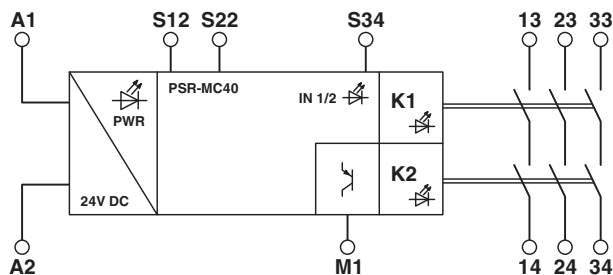

Figure 3 Block diagram

Key:

- A1** 24 V DC power supply
- A2** 0 V power supply
- M1** Signal output (PNP), not security-relevant
- S12** Input sensor circuit (channel 1)
- S22** Input sensor circuit (channel 2)
- S34** Start circuit
- 13/14**
- 23/24** Undelayed enabling current paths
- 33/34**

9 Derating

9.1 Vertical or horizontal mounting position

The derating curve applies for the following conditions:

- Mounting on a vertical or horizontal DIN rail
- Devices mounted next to each other without spacing

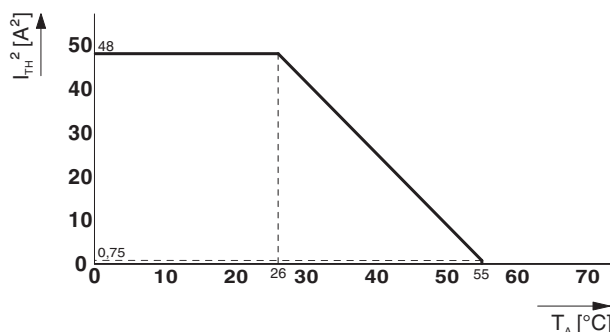

Figure 4 Derating curve - vertical or horizontal mounting position, without spacing

10 Load curve

10.1 Ohmic and inductive load

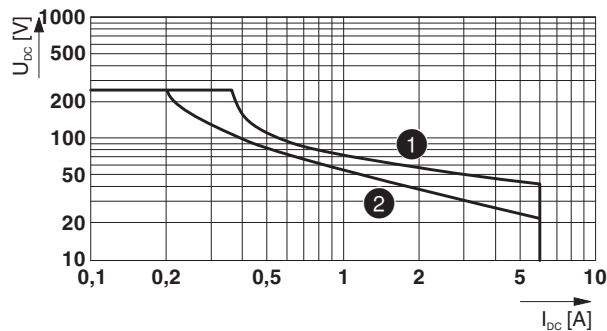

Figure 5 Relay load curve - ohmic and inductive load

Key:

- ① Ohmic load L/R = 0 ms
- ② Inductive load L/R = 40 ms

11 Operating and indication elements

11.1 Connection versions

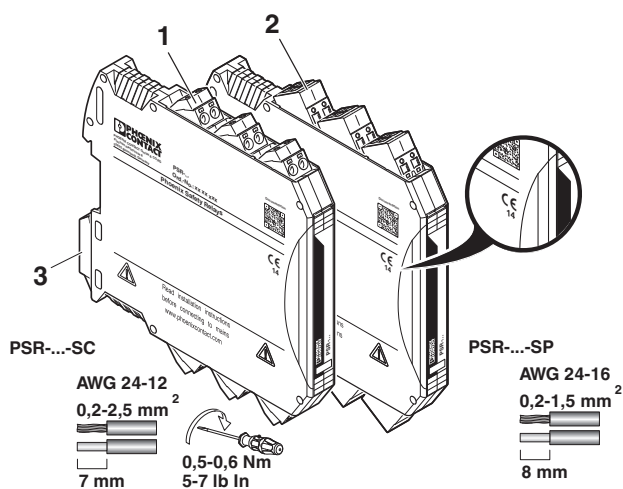

- 1 COMBICON plug-in screw terminal block
- 2 COMBICON plug-in spring-cage terminal block
- 3 Metal lock for fixing to DIN rail



The year the device was constructed can be found underneath the CE designation on the housing.

Figure 6 Connection versions

11.2 Connection assignment

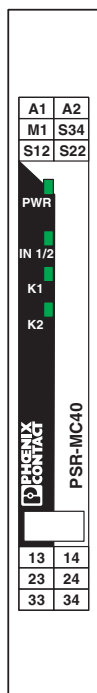

- A1** 24 V DC power supply
- A2** 0 V power supply
- M1** Signal output (PNP), not security-relevant
- S34** Start circuit
- S12** Input sensor circuit (channel 1)
- S22** Input sensor circuit (channel 2)
- PWR** Power LED (green)
- IN1/2** Status indicator sensor circuit; LED (green)
- K1** Status indicator safety circuit; LED (green)
- K2** Status indicator safety circuit; LED (green)

- 13/14**
- 23/24** Undelayed enabling current paths
- 33/34**

12 Mounting and removing

- Mount the device on a 35 mm DIN rail according to EN 60715.
- To remove the device, use a screwdriver to release the snap-on foot.

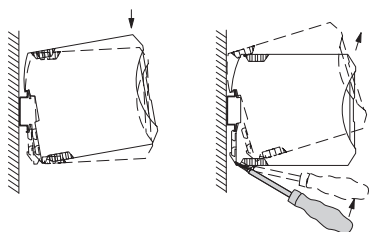

Figure 7 Mounting and removing

13 Wiring

- Connect the cables to the connection terminal blocks using a screwdriver.

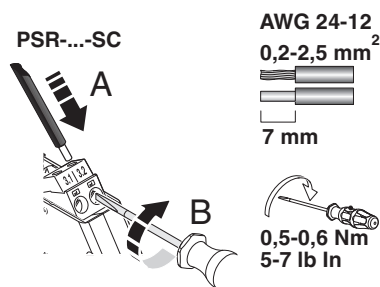

Figure 8 Connecting the cables for PSR-...-SC (screw terminal block)

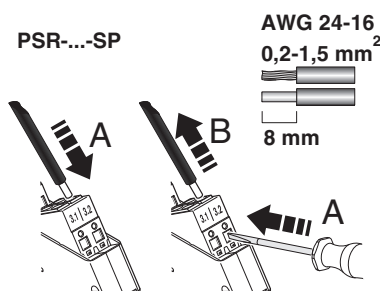

Figure 9 Connecting the cables for PSR-...-SC (spring-cage terminal block)



It is recommended that ferrules are used to connect stranded cables.



For compliance with UL approval, use copper wire that is approved up to 60°C/75°C.

13.1 Signal generator connection versions

- Connect suitable signal generators to S12/S22.

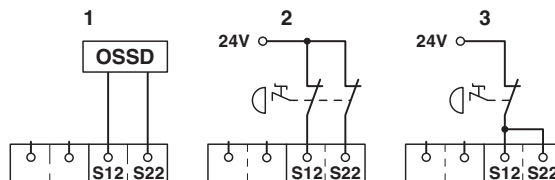

Figure 10 Signal generator connection versions

- 1 Two-channel connection with **external** cross-circuit monitoring
- 2 Two-channel connection without cross-circuit monitoring
- 3 Single-channel connection

13.2 Start and feedback circuit connection variants

Automatic start

- Connect contact S34 to 0 V.

Manual, monitored start

- Connect a reset button to contacts A1/S34. A connected reset button is monitored.

Start and feedback circuit

- Place the relevant N/C contact in path 0 V/S34 or A1/S34 to monitor external contactors or extension devices with force-guided contacts.

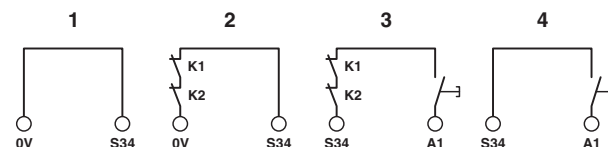

Figure 11 Start and feedback circuit connection variants

- 1 Automatic start
- 2 Automatic start with monitored contact extension
- 3 Manual, monitored start with monitored contact extension
- 4 Manual, monitored start

14 Startup

- Apply the rated control circuit supply voltage (24 V DC) at terminal blocks A1/A2.

The Power LED lights up.

- Close the sensor circuit at 24 V/S12 and 24 V/S22 as per the wiring.

The IN1/2 LED lights up.



Single or two-channel sensor circuit: see "Signal generator connection versions".

Automatic start

The enabling current paths 13/14, 23/24 and 33/34 close.

The K1 and K2 LEDs light up.

Signal output M1 is not active.

Manual, monitored start

- Press the reset button.
- Release the reset button.

The enabling current paths 13/14, 23/24 and 33/34 close.

The K1 and K2 LEDs light up.

Signal output M1 is not active.

15 Calculating the power dissipation



The total power dissipation of the safety relay is based on the input power dissipation and the contact power dissipation for the same and for different load currents.

Input power dissipation

$$P_{\text{Input}} = U_B^2 / (U_S / I_S)$$

Contact power dissipation

With the same load currents:

$$P_{\text{Contact}} = n \cdot I_L^2 \cdot 50 \text{ m}\Omega$$

With different load currents:

$$P_{\text{Contact}} = (I_{L1}^2 + I_{L2}^2 + \dots + I_{Ln}^2) \cdot 50 \text{ m}\Omega$$

Total power dissipation

$$P_{\text{Total}} = P_{\text{Input}} + P_{\text{Contact}}$$

therefore

$$P_{\text{Total}} = U_B^2 / (U_S / I_S) + n \cdot I_L^2 \cdot 50 \text{ m}\Omega$$

or

$$P_{\text{Total}} = U_B^2 / (U_S / I_S) + (I_{L1}^2 + I_{L2}^2 + \dots + I_{Ln}^2) \cdot 50 \text{ m}\Omega$$

Key:

- P** Power dissipation in mW
- U_B** Applied operating voltage
- U_S** Rated control circuit supply voltage
- I_S** Rated control supply current
- n** Number of enabling current paths used
- I_L** Contact load current

16 Diagnostics

The following section describes the LED indicators for general states and error messages as well as possible causes and remedies.

Signal output M1 - not safety-related



Signal output M1 transmits non-safety-related status information. Feedback of signal output M1 to external basic devices for reasons of functional safety is therefore not required.

Function test/proof test

To verify the device function, proceed as follows:

- Demand the safety function by actuating the corresponding safety equipment.
- Check whether the safety function was executed correctly by switching the device on again.

If the device does not switch on again, the proof test failed.



WARNING: Loss of functional safety due to malfunction.

If the proof test contains errors, the device no longer functions correctly.

- Replace the device.

16.1 General states

PWR LED	IN1/2 LED	K1 LED	K2 LED	State	Notes
ON	OFF	OFF	OFF	All relays are not activated. The sensor circuit is off.	Possible error see error messages
ON	ON	OFF	OFF	The sensor circuit is active. Relays K1 and K2 are ready to start and await reset/start command (S34).	
ON	ON	ON	ON	The sensor circuit is active. All relays are picked up.	-

16.2 Error Messages

PWR LED	IN1/2 LED	K1 LED	K2 LED	State	Possible cause	Corrective
ON	OFF	OFF	OFF	The sensor circuit is actively controlled, but no input LEDs are lit up.	Interrupt in the sensor circuit or faulty signal generator.	Check the sensor circuit/signal generator. Then perform a function test.
ON	ON	OFF	OFF	The sensor circuit is active. The reset/start circuit (S34) is/was activated. The safety circuit (K1 and K2) is not picking up.	External error: the readback contact (external actuator) is open in the reset circuit. Internal error: 1. The diagnostic contact is not working correctly. 2. An N/O contact is welded.	External error: check the actuator. Internal error: perform a power down reset with subsequent function test. If the error occurs again after the function test, replace the device.
ON	ON	OFF	OFF	The sensor circuit is active. The reset/start circuit (S34) is/was activated. The safety circuit (K1 and K2) is not picking up.	Error during manual reset S34 (stuck-at at the input).	Remove the error in the reset/start circuit. Then perform a function test.
ON	ON	OFF	ON	The sensor circuit is active. The reset/start circuit (S34) is/was activated. The safety circuit (K1) is not picking up.	External error: sensor circuit channel 1 was opened and reactivated. Internal error: diagnostics active.	External error: check the sensor circuit. Internal error: perform a power down reset with subsequent function test. If the error occurs again after the function test, replace the device.
ON	ON	ON	OFF	The sensor circuit is active. The reset/start circuit (S34) is/was activated. The safety circuit (K2) is not picking up.	External error: sensor circuit channel 2 was opened and reactivated. Internal error: diagnostics active.	External error: check the sensor circuit. Internal error: perform a power down reset with subsequent function test. If the error occurs again after the function test, replace the device.
OFF	OFF	OFF	OFF	The sensor circuit is active.	1. No supply voltage at A1/A 2. Over- or undervoltage at A1	Check the supply voltage.

17 Application examples

17.1 Emergency stop monitoring/automatic start

- Two-channel emergency stop monitoring
- Automatic start
- Monitoring of external, force-guided contactors
- No cross-circuit detection in the sensor circuit
- Suitable up to category 4, PL e (EN ISO 13849-1), SIL 3 (EN 62061), if cross-circuits in the control to the actuator and the sensor circuit can be ruled out



Cross-circuits in the cable installation can be excluded if the safety relay and external contactors K1 and K2 are located in the same electrical installation space.

For sensor circuits in the field, prevent cross-circuits by using a cable installation that is protected mechanically.

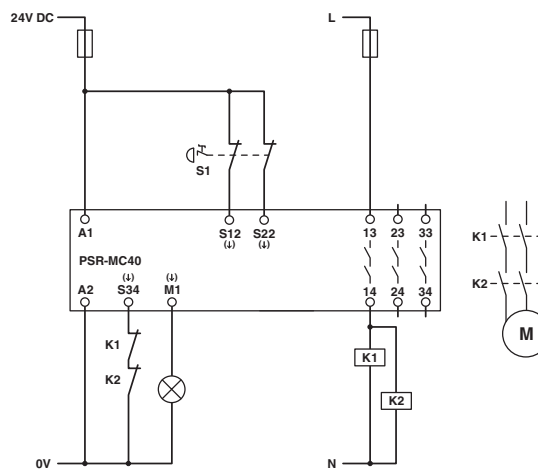

Figure 12 Emergency stop monitoring/automatic start

Key:

- S1** Emergency stop button
K1/K2 Force-guided contactors

17.2 Emergency stop monitoring/manual, monitored start

- Two-channel emergency stop monitoring
- Manual, monitored start
- Monitoring of external, force-guided contactors
- No cross-circuit detection in the sensor circuit
- Suitable up to category 4, PL e (EN ISO 13849-1), SIL 3 (EN 62061), if cross-circuits in the control to the actuator and the sensor circuit can be ruled out



Cross-circuits in the cable installation can be excluded if the safety relay and external contactors K1 and K2 are located in the same electrical installation space.

For sensor circuits in the field, prevent cross-circuits by using a cable installation that is protected mechanically.



WARNING: Risk of automatic machine restart!

If the manual reset function with monitored start is used, a cross-circuit between A2 (0 V) and the cable from the reset button to S34 can result in automatic machine startup.

- Prevent a cross-circuit between A2 (0 V) and the cable from the reset button to S34 by means of design measures (see error prevention in accordance with EN ISO 13849-2).

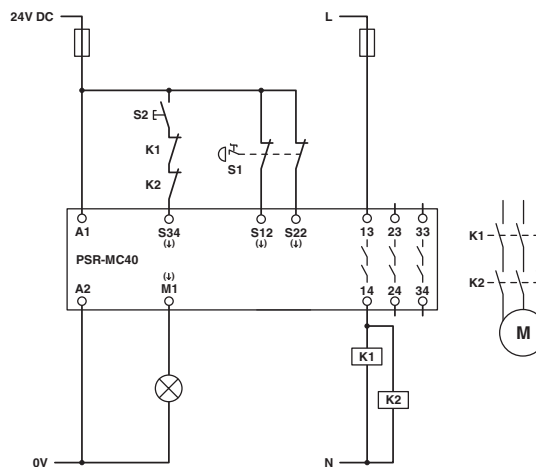

Figure 13 Emergency stop monitoring/manual, monitored start

Key:

- S1** Emergency stop button
S2 Manual reset device
K1/K2 Force-guided contactors

17.3 Safety door monitoring/automatic start

- Two-channel safety door monitoring
- Automatic start
- Monitoring of external, force-guided contactors
- No cross-circuit detection in the sensor circuit
- Suitable up to category 4, PL e (EN ISO 13849-1), SIL 3 (EN 62061), if cross-circuits in the control to the actuator and the sensor circuit can be ruled out



Cross-circuits in the cable installation can be excluded if the safety relay and external contactors K1 and K2 are located in the same electrical installation space.

For sensor circuits in the field, prevent cross-circuits by using a cable installation that is protected mechanically.

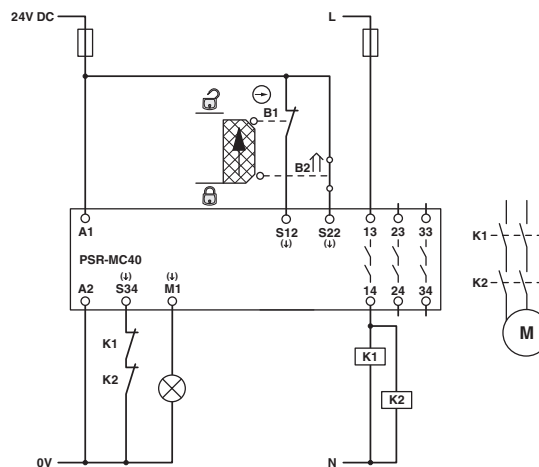

Figure 14 Safety door monitoring/automatic start

Key:

- B1/B2** Mechanical safety door switches
K1/K2 Force-guided contactors

17.4 Safety door monitoring/manual, monitored start

- Two-channel safety door monitoring
- Manual, monitored start
- Monitoring of external, force-guided contactors
- No cross-circuit detection in the sensor circuit
- Suitable up to category 4, PL e (EN ISO 13849-1), SIL 3 (EN 62061), if cross-circuits in the control to the actuator and the sensor circuit can be ruled out



Cross-circuits in the cable installation can be excluded if the safety relay and external contactors K1 and K2 are located in the same electrical installation space.

For sensor circuits in the field, prevent cross-circuits by using a cable installation that is protected mechanically.



WARNING: Risk of automatic machine restart!

If the manual reset function with monitored start is used, a cross-circuit between A2 (0 V) and the cable from the reset button to S34 can result in automatic machine startup.

- Prevent a cross-circuit between A2 (0 V) and the cable from the reset button to S34 by means of design measures (see error prevention in accordance with EN ISO 13849-2).

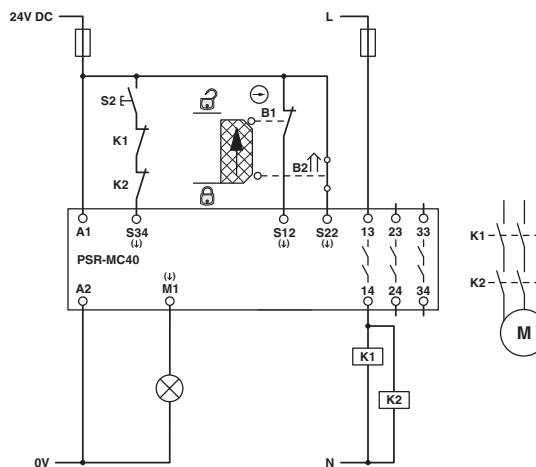

Figure 15 Safety door monitoring/manual, monitored start

Key:

- S2** Manual reset device
B1/B2 Mechanical safety door switches
K1/K2 Force-guided contactors

17.5 Single-channel safety door monitoring/automatic start

- Single-channel safety door monitoring
- Automatic start
- Monitoring of external, force-guided contactors
- No cross-circuit detection in the sensor circuit
- Suitable up to category 1, PL c (EN ISO 13849-1), SIL 1 (EN 62061)

i Contactor K2 is not essential in order to achieve category 1.

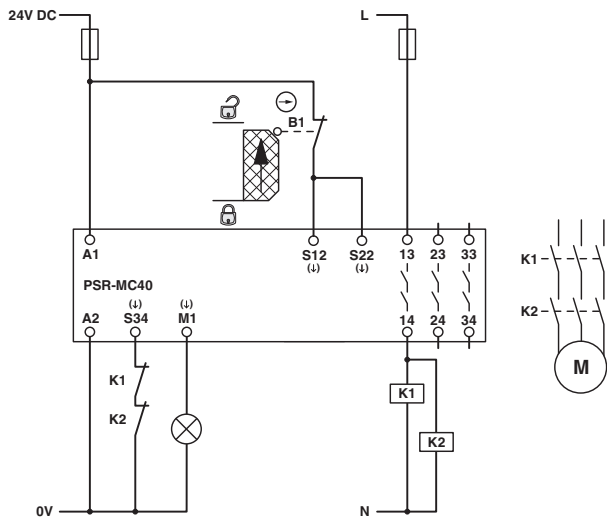

Figure 16 Single-channel safety door monitoring/automatic start

Key:

- S2** Manual reset device
- B1/B2** Mechanical safety door switches
- K1/K2** Force-guided contactors

17.6 Single-channel safety door monitoring/manual, monitored start

- Single-channel safety door monitoring
- Manual, monitored start
- Monitoring of external, force-guided contactors
- No cross-circuit detection in the sensor circuit
- Suitable up to category 1, PL c (EN ISO 13849-1), SIL 1 (EN 62061)

i Contactor K2 is not essential in order to achieve category 1.



WARNING: Risk of automatic machine restart!

If the manual reset function with monitored start is used, a cross-circuit between A2 (0 V) and the cable from the reset button to S34 can result in automatic machine startup.

- Prevent a cross-circuit between A2 (0 V) and the cable from the reset button to S34 by means of design measures (see error prevention in accordance with EN ISO 13849-2).

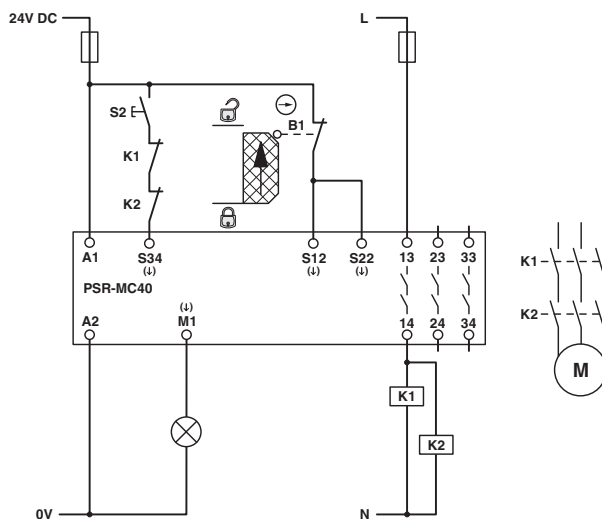

Figure 17 Single-channel safety door monitoring/manual, monitored start

Key:

- B1** Mechanical safety door switch
- K1/K2** Force-guided contactors

17.7 Connection to failsafe controller/automatic start

- Two-channel connection to the failsafe PLC
- Automatic start
- Monitoring of external, force-guided contactors
- No cross-circuit detection in the sensor circuit
- Suitable up to category 4, PL e (EN ISO 13849-1), SIL 3 (EN 62061), if the failsafe controller meets PL e, SIL 3



WARNING: Loss of functional safety!

Make sure that the signal generator and the safety relay have the same ground potential.



WARNING: Loss of functional safety!

The switch-on pulses sent by the controller (light test) can lead to brief, unwanted activation of the safety relay.

- Deactivate the light pulses/light tests, unless they are safety-related.

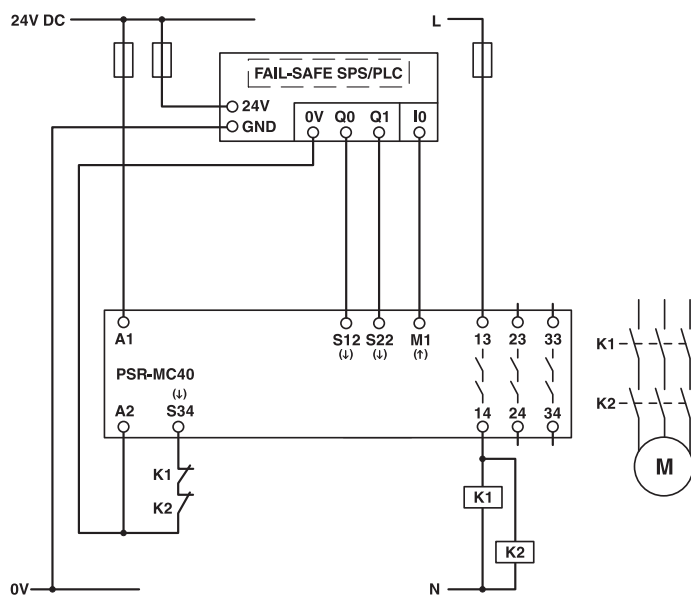

Figure 18 Connection to error-free PLC/automatic start

Key:

- Q0, Q1** Digital outputs
- I0** Digital input
- K1/K2** Force-guided contactors

17.9 Single-channel connection to failsafe controller/automatic start

- Single-channel connection to the failsafe PLC
- Automatic start
- Monitoring of external, force-guided contactors
- No cross-circuit detection in the sensor circuit
- Suitable up to category 4, PL e (EN ISO 13849-1), SIL 3 (EN 62061), if the failsafe controller meets PL e, SIL 3 and cross-circuits can be ruled out



WARNING: Loss of functional safety!
 Make sure that the signal generator and the safety relay have the same ground potential.



WARNING: Loss of functional safety!
 The switch-on pulses sent by the controller (light test) can lead to brief, unwanted activation of the safety relay.

- Deactivate the light pulses/light tests, unless they are safety-related.

i Cross-circuits in the cable installation can be excluded if the failsafe PLC, safety relay, and external contactors K1 and K2 are located in the same electrical installation space.

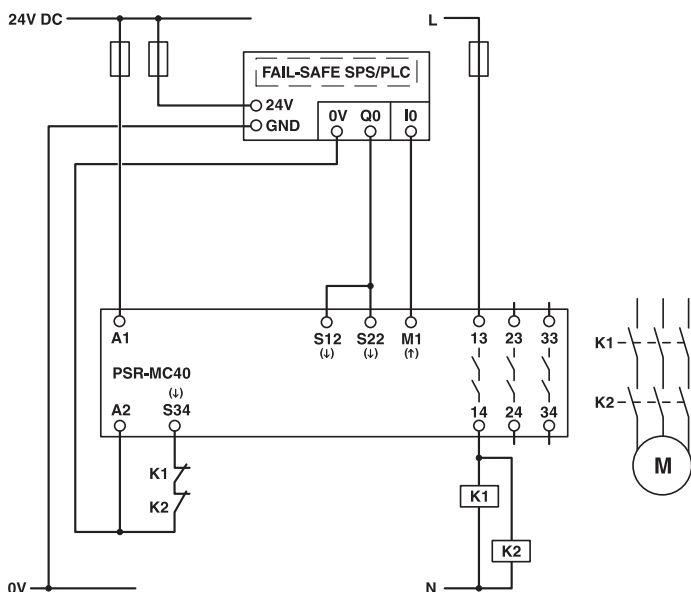

Figure 20 Single-channel connection to failsafe PLC/automatic start

Key:

- Q0** Digital output
- I0** Digital input
- K1/K2** Force-guided contactors

17.10 Single-channel connection to failsafe controller/manual, monitored start

- Single-channel connection to the failsafe PLC
- Manual, monitored start
- Monitoring of external, force-guided contactors
- No cross-circuit detection in the sensor circuit
- Suitable up to category 4, PL e (EN ISO 13849-1), SIL 3 (EN 62061), if the failsafe controller meets PL e, SIL 3 and cross-circuits can be ruled out



WARNING: Loss of functional safety!
 The switch-on pulses sent by the controller (light test) can lead to brief, unwanted activation of the safety relay.

- Deactivate the light pulses/light tests, unless they are safety-related.



Cross-circuits in the cable installation can be excluded if the failsafe PLC, safety relay, and external contactors K1 and K2 are located in the same electrical installation space.



WARNING: Risk of automatic machine restart!
 If the manual reset function with monitored start is used, a cross-circuit between A2 (0 V) and the cable from the reset button to S34 can result in automatic machine startup.

- Prevent a cross-circuit between A2 (0 V) and the cable from the reset button to S34 by means of design measures (see error prevention in accordance with EN ISO 13849-2).



WARNING: Loss of functional safety!
 Make sure that the signal generator and the safety relay have the same ground potential.

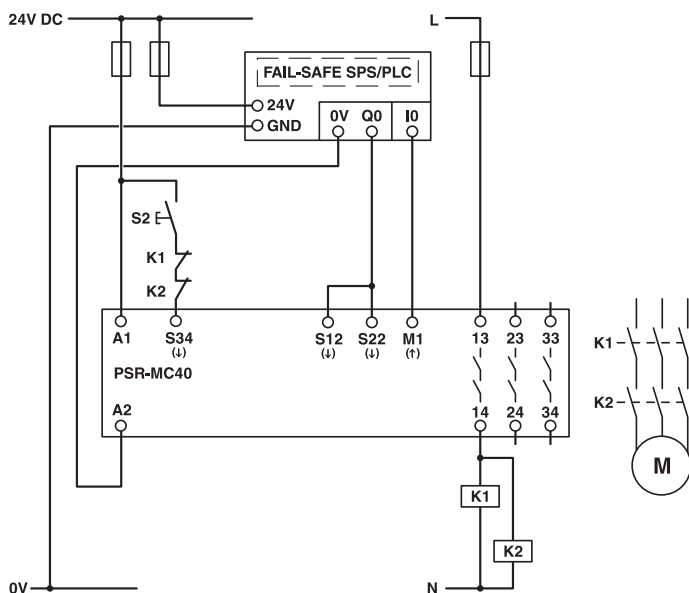

Figure 21 Single-channel connection to failsafe PLC/manual, monitored start

Key:

- S2** Manual reset device
- Q0** Digital output
- I0** Digital input
- K1/K2** Force-guided contactors

17.11 Light grid monitoring/automatic start

- Two-channel light grid monitoring
- Automatic start
- Monitoring of external, force-guided contactors
- No cross-circuit detection in the sensor circuit
- Suitable up to category 4, PL e (EN ISO 13849-1), SIL 3 (EN 62061), if cross-circuits in the control to the actuator can be ruled out



Cross-circuits in the cable installation can be excluded if the safety relay and external contactors K1 and K2 are located in the same electrical installation space.



WARNING: Loss of functional safety!
Make sure that the signal generator and the safety relay have the same ground potential.

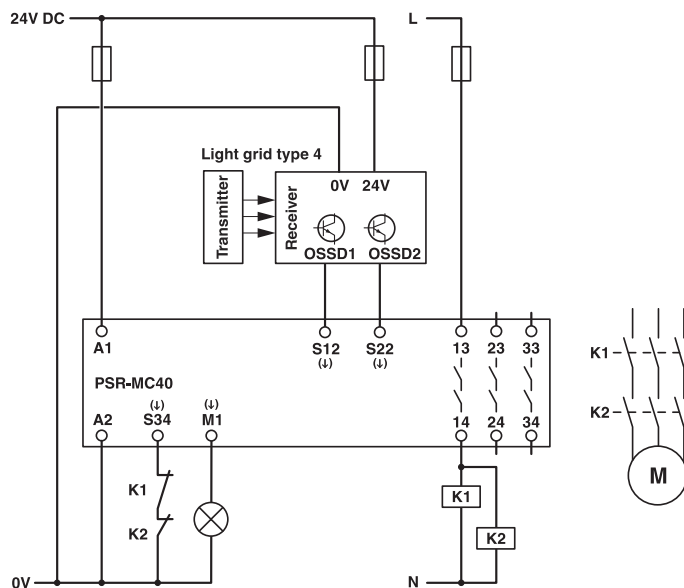

Figure 22 Light grid monitoring/automatic start

Key:

K1/K2 Force-guided contactors

17.12 Light grid monitoring/manual, monitored start

- Two-channel light grid monitoring
- Manual, monitored start
- Monitoring of external, force-guided contactors
- No cross-circuit detection in the sensor circuit
- Suitable up to category 4, PL e (EN ISO 13849-1), SIL 3 (EN 62061), if cross-circuits in the control to the actuator can be ruled out



WARNING: Loss of functional safety!
 Make sure that the signal generator and the safety relay have the same ground potential.



WARNING: Risk of automatic machine restart!
 If the manual reset function with monitored start is used, a cross-circuit between A2 (0 V) and the cable from the reset button to S34 can result in automatic machine startup.

- Prevent a cross-circuit between A2 (0 V) and the cable from the reset button to S34 by means of design measures (see error prevention in accordance with EN ISO 13849-2).



Cross-circuits in the cable installation can be excluded if the safety relay and external contactors K1 and K2 are located in the same electrical installation space.

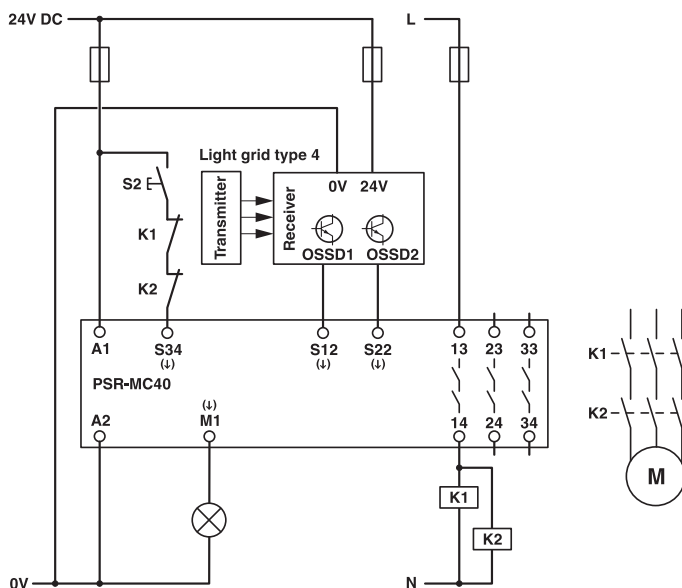

Figure 23 Light grid monitoring/manual, monitored start

Key:

- S2** Manual reset device
- K1/K2** Force-guided contactors

17.13 Transponder monitoring/automatic start

- Two-channel transponder monitoring
- Automatic start
- Monitoring of external, force-guided contactors
- No cross-circuit detection in the sensor circuit
- Suitable up to category 4, PL e (EN ISO 13849-1), SIL 3 (EN 62061), if cross-circuits in the control to the actuator can be ruled out



Cross-circuits in the cable installation can be excluded if the safety relay and external contactors K1 and K2 are located in the same electrical installation space.



WARNING: Loss of functional safety!
Make sure that the signal generator and the safety relay have the same ground potential.

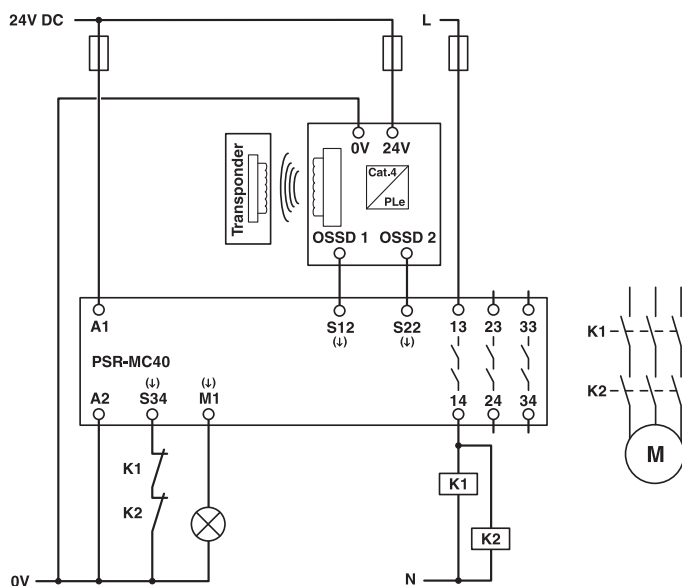

Figure 24 Transponder monitoring/automatic start

Key:

K1/K2 Force-guided contactors

17.14 Transponder monitoring/manual, monitored start

- Two-channel transponder monitoring
- Manual, monitored start
- Monitoring of external, force-guided contactors
- No cross-circuit detection in the sensor circuit
- Suitable up to category 4, PL e (EN ISO 13849-1), SIL 3 (EN 62061), if cross-circuits in the control to the actuator can be ruled out



WARNING: Loss of functional safety!
 Make sure that the signal generator and the safety relay have the same ground potential.



WARNING: Risk of automatic machine restart!
 If the manual reset function with monitored start is used, a cross-circuit between A2 (0 V) and the cable from the reset button to S34 can result in automatic machine startup.

- Prevent a cross-circuit between A2 (0 V) and the cable from the reset button to S34 by means of design measures (see error prevention in accordance with EN ISO 13849-2).



Cross-circuits in the cable installation can be excluded if the safety relay and external contactors K1 and K2 are located in the same electrical installation space.

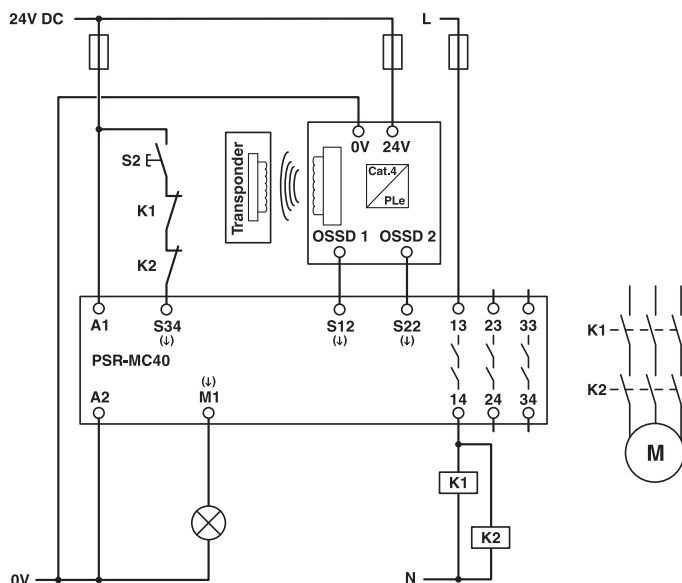

Figure 25 Transponder monitoring/manual, monitored start

Key:

- S2** Manual reset device
- K1/K2** Force-guided contactors

18 Attachment

18.1 Using PSR devices at altitudes greater than 2000 m above sea level



The following section describes the special conditions for using PSR devices at altitudes greater than 2000 m above sea level. Observe the relevant device-specific data (technical data, derating, etc.) according to the product documentation for the individual device.

Using the device at altitudes **greater than 2000 m above sea level up to max. 4500 m above sea level** is possible under the following conditions:

1. Limit the rated control circuit supply voltage (U_S) in accordance with the table below. Observe the technical data for the device.

U_S according to the technical data for the device	U_S when used at altitudes greater than 2000 m above sea level
< 150 V AC/DC	U_S according to the technical data for the device still valid
> 150 V AC/DC	Limited to max. 150 V AC/DC

2. Limit the maximum switching voltage in accordance with the table below. Observe the technical data for the device.

Max. switching voltage according to the technical data for the device	Max. switching voltage when used at altitudes greater than 2000 m above sea level
< 150 V AC/DC	Max. switching voltage according to the technical data for the device still valid
> 150 V AC/DC	Limited to max. 150 V AC/DC

3. Reduce the maximum ambient temperature for operation by the corresponding factor in accordance with the table below.
4. If derating is specified, offset all the points of the derating curve by the corresponding factor in accordance with the table below.

Altitude above sea level	Temperature derating factor
2000 m	1
2500 m	0.953
3000 m	0.906
3500 m	0.859
4000 m	0.813
4500 m	0.766

Example calculation for 3000 m



The following calculation and the illustrated derating curve are provided as examples. Perform the actual calculation and offset the derating curve for the device used according to the technical data and the "Derating" section.

$$27\text{ °C} \cdot 0.906 \approx 24\text{ °C}$$

$$55\text{ °C} \cdot 0.906 \approx 49\text{ °C}$$

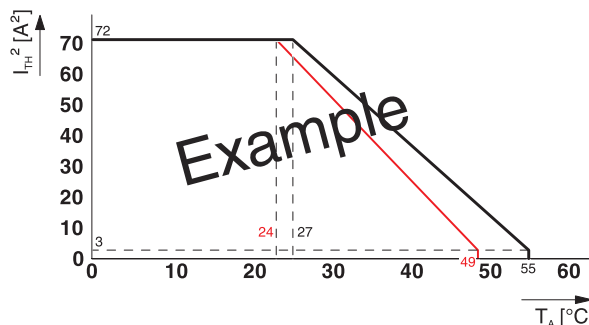

Figure 26 Example of a suspended derating curve (red)

18.2 Revision history

Version	Date	Contents
00	2014-12-03	First publication
01	2015-03-05	Reverse polarity protection extended; relay type extended; dimensions updated; load curve extended
02	2015-03-05	Input voltage range "0" signal supplemented; relay type changed; application examples and notes on examples revised
03	2016-09-30	New edition of the data sheet: layout and structure revised; input current for "0" signal extended; output data (min. switching voltage) adjusted; note added regarding the protection of the 24 V area; inductive load curve extended; connection reset in Figure 11 adjusted; notes in application examples section extended; section on use at altitudes greater than 2000 m above sea level extended; information added regarding M1 = not safety-related



SCATTERGOOD & JOHNSON LTD

ELECTRICAL ENGINEERING & FLUID CONTROL DISTRIBUTORS

Est.1899

At Scattergood & Johnson Ltd, we pride ourselves on being a technical distributor to specialist industries.

Working with a range of quality product suppliers across a number of specialist markets, we are not your average 'box shifter' - we are your technical and supply chain partner.

We fully support every product we sell - for free! Our internal team and external sales engineers can answer any product or application question, no matter the complexity.

Backing up this technical ability is a range of 50,000+ products available from stock for nationwide next day delivery (same day if required!), or you can collect what you need from any of our trade counters around the UK.

Select your specialist interest below to learn more about how we can help.

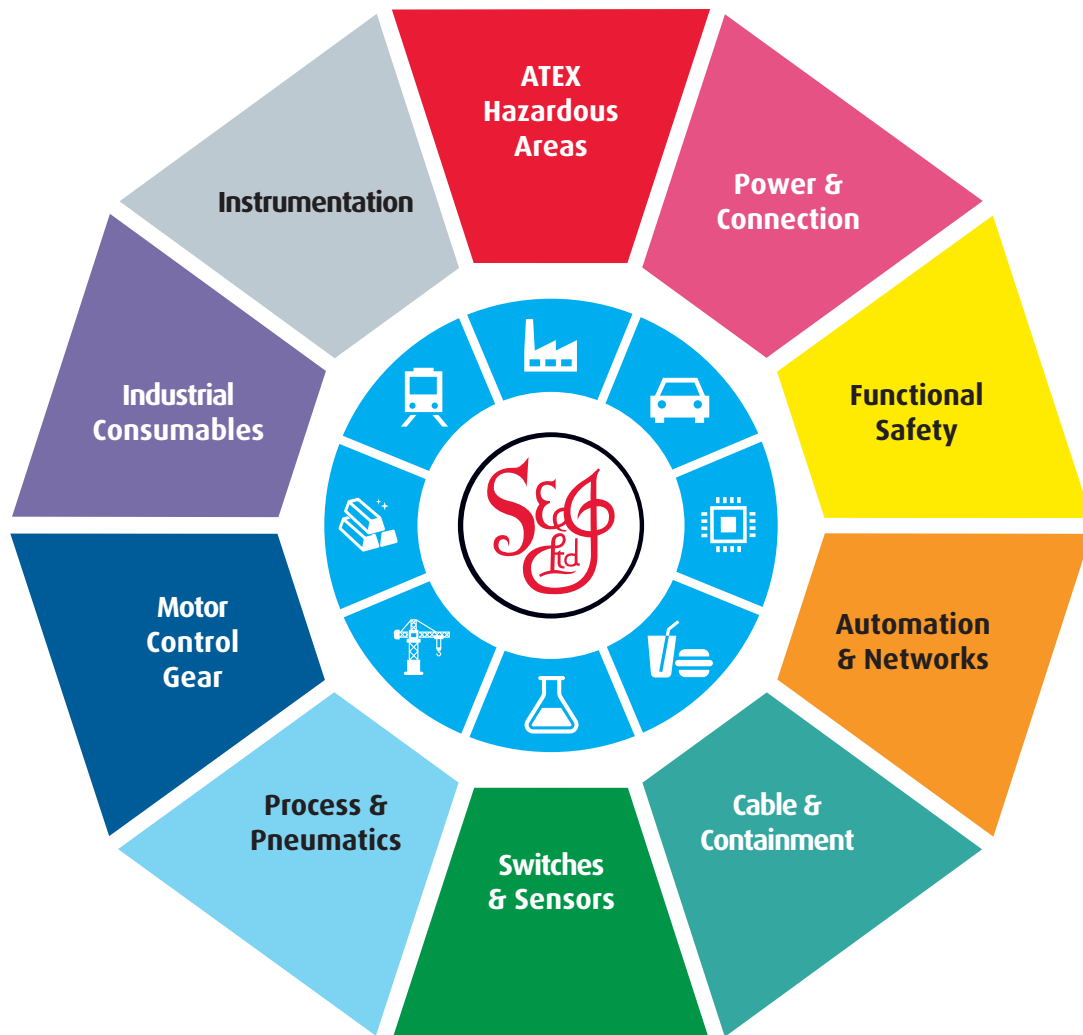

Online, In Branch and On the Road - Scattergood & Johnson Ltd, there when you need us.

www.scatts.co.uk