

PSR-MM25

PL
EN ISO 13849

SILCL
IEC 62061



Safety relay module for zero-speed monitoring

Data sheet
106670_en_05

© PHOENIX CONTACT 2017-09-22

1 Description

Intended Use

The safety relay module is used for machine zero-speed monitoring without sensors.

Zero-speed is detected by evaluating the voltage induced by the motor winding (e.m.f.).

The switching device interrupts circuits in a safety-related way.

Possible drive systems

- Single-phase AC motors
- Three-phase AC motors
- DC motors
- Speed-regulated motors on frequency inverters

Contact type

- 1 safe enabling current path
- 2 digital alarm outputs

The enabling current path drops out without delay according to stop category 0 (EN 60204-1).

The standard, digital signal outputs are used to transmit the status to a higher-level controller.

Functional properties

- Two-channel evaluation
- Automatic start

Achievable safety integrity

- Suitable up to category 3, PL e (EN ISO 13849-1), SILCL 3 (EN 62061)

Additional features

- No additional sensors required
- Adjustable switching threshold
- Adjustable switch-on delay
- Option of screw or spring-cage terminal blocks for plug-in
- 12.5 mm housing width

Approvals



WARNING: Risk of electric shock

Observe the safety regulations and installation notes in the corresponding section.



Make sure you always use the latest documentation.

It can be downloaded from the product at phoenixcontact.net/products.



This document is valid for the products listed in the "Ordering data".

This document meets the same requirements as the original operating instructions with respect to the contents.

| | | |
|----------|--|----|
| 2 | Table of contents | |
| 1 | Description | 1 |
| 2 | Table of contents | 2 |
| 3 | Ordering data | 3 |
| 4 | Technical data | 4 |
| 5 | Safety regulations and installation notes..... | 7 |
| 6 | Function description | 8 |
| 7 | Function and time diagrams | 10 |
| 8 | Basic circuit diagram | 10 |
| 9 | Derating..... | 11 |
| 10 | Load curve..... | 11 |
| 11 | Operating and indication elements | 12 |
| 12 | Mounting and removing | 13 |
| 13 | Wiring | 13 |
| 14 | Startup..... | 14 |
| 15 | Parameterization | 14 |
| 16 | Diagnostics..... | 17 |
| 17 | Application examples | 19 |
| 18 | Attachment | 21 |

3 Ordering data

| Description | Type | Order No. | Pcs./Pkt. |
|---|--------------------------|-----------|-----------|
| Safety relay module for sensorless standstill monitoring for 3- and 1-phase motors to SILCL 3, cat. 3, PL e, two-channel evaluation of the residual voltage of AC, three-phase, and DC motors, plug-in screw terminal block, width: 12.5 mm | PSR-MM25-1NO-2DO-24DC-SC | 2702355 | 1 |
| Safety relay module for sensorless standstill monitoring for 3- and 1-phase motors to SILCL 3, cat. 3, PL e, two-channel evaluation of the residual voltage of AC, three-phase, and DC motors, plug-in spring-cage terminal block, width: 12.5 mm | PSR-MM25-1NO-2DO-24DC-SP | 2702356 | 1 |
| Accessories | Type | Order No. | Pcs./Pkt. |
| Ring cable lug, blue, 1.5 ... 2.5 mm ² , M4 Ring cable lug, length: 23 mm, width: 8.5 mm, color: blue | C-RCI 2,5/M4 | 3240023 | 100 |
| Ring cable lug, blue, 1.5 ... 2.5 mm ² , M6 Ring cable lug, length: 28.1 mm, width: 12 mm, color: blue | C-RCI 2,5/M6 | 3240025 | 50 |
| Ring cable lug, blue, 1.5 ... 2.5 mm ² , M8 Ring cable lug, length: 28.1 mm, width: 12 mm, color: blue | C-RCI 2,5/M8 | 3240026 | 50 |
| Ring cable lug, non-insulated, 1.1 ... 2.5 mm ² , M3,5 Ring cable lug, length: 14 mm, width: 6 mm, color: silver | C-RC 2,5/M3,5 DIN | 3240077 | 100 |
| Ring cable lug, non-insulated, 1.1 ... 2.5 mm ² , M5 Ring cable lug, length: 19 mm, width: 10 mm, color: silver | C-RC 2,5/M5 DIN | 3240079 | 100 |
| Ring cable lug, non-insulated, 1.1 ... 2.5 mm ² , M6 Ring cable lug, length: 21.5 mm, width: 11 mm, color: silver | C-RC 2,5/M6 DIN | 3240080 | 100 |
| Ring cable lug, non-insulated, 1.1 ... 2.5 mm ² , M8 Ring cable lug, length: 24 mm, width: 14 mm, color: silver | C-RC 2,5/M8 DIN | 3240081 | 100 |
| Ring cable lug, non-insulated, 1.1 ... 2.5 mm ² , M10 Ring cable lug, length: 25.4 mm, width: 14 mm, color: silver | C-RC 2,5/M10 DIN | 3240082 | 100 |

4 Technical data

Hardware/firmware version

HW/FW \geq 00/100

The technical data and safety characteristics are valid as of the specified HW/FW version.

Input data

| | |
|--|--|
| Rated control circuit supply voltage U_S | 24 V DC -15 % / +10 % |
| Rated control supply current I_S | typ. 50 mA |
| Inrush current | 5.6 A ($\Delta t = 400 \mu s$ at U_S) |
| Current consumption | max. 0.35 mA (at L1/L2/L3) |
| Voltage input signal | max. 690 V AC/DC (at L1/L2/L3) |
| Power consumption at U_S | typ. 1.2 W |
| Filter time | 1 ms (at A1 in the event of voltage dips at U_S) |
| Typical starting time with U_S | < 1 s |
| Delay time range | 0.5 s ... 20 s \pm 1 % (K1, K2 can be parameterized) |
| Maximum switching frequency | 0.5 Hz |
| Limit frequency | max. 3 kHz (At voltages > 2 V_{RMS}) |
| Status display | 4 x LED Bi-Colour |
| Protective circuit | Surge protection Suppressor diode Protection against polarity reversal for rated control circuit supply voltage |

Output data

| | |
|---|---------------------------------------|
| Contact type | 1 enabling current path |
| Contact material | AgSnO ₂ |
| Minimum switching voltage | 24 V AC/DC |
| Maximum switching voltage | 250 V AC/DC (Observe the load curve) |
| Limiting continuous current | 5 A (observe derating) |
| Maximum inrush current | 5 A |
| Inrush current, minimum | 3 mA |
| Sq. Total current $I_{TH}^2 = I_1^2 + I_2^2 + \dots + I_N^2$ | 25 A ² (observe derating) |
| Switching capacity | min. 72 mW |
| Mechanical service life | 10 x 10 ⁶ cycles |
| Response time | typ. 20 ms (at 50 Hz input frequency) |
| Output fuse | 5 A gL/gG (N/O contact) |

Alarm outputs

| | |
|--------------------------|------------------------|
| Number of outputs | 2 (digital, PNP) |
| Voltage | 23 V DC ($U_S - 1$ V) |
| Current | max. 100 mA |
| Maximum inrush current | 500 mA |
| Short-circuit protection | Yes |

| General data | | |
|--|--|---|
| Nominal operating mode | 100% operating factor | |
| Degree of protection | IP20 | |
| Min. degree of protection of inst. location | IP54 | |
| Mounting type | DIN rail mounting | |
| Mounting position | vertical or horizontal | |
| Assembly instructions | See derating curve | |
| Weight | 150.1 g | |
| Type of housing | PBT yellow | |
| Air clearances and creepage distances between the power circuits | according to DIN EN 50178 | |
| Rated insulation voltage | 250 V AC 400 V AC with isolation paths between (L1/L2/L3) and the remaining current paths 690 V AC (with isolation paths within L1/L2/L3) | |
| Rated surge voltage/insulation | Basic insulation 4 kV: between all current paths and housing Basic insulation 8 kV: between L1 and L2 between L1 and L3 between L2 and L3 Safe isolation, reinforced insulation 6 kV: between A1/A2 and 13/14 between MO/FO and 13/14 Safe isolation, reinforced insulation 8 kV: between L1/L2/L3 and A1/A2 between L1/L2/L3 and MO/FO between L1/L2/L3 and 13/14 | |
| Degree of pollution | 2 | |
| Overvoltage category | III | |
| Dimensions | Screw connection | Spring-cage connection |
| W x H x D | 12.5 x 112.2 x 114.5 mm | 12.5 x 116.6 x 114.5 mm |
| Connection data | Screw connection | Spring-cage connection |
| Conductor cross section, solid | 0.2 mm ² ... 2.5 mm ² | 0.2 mm ² ... 1.5 mm ² |
| Conductor cross section, flexible | 0.2 mm ² ... 2.5 mm ² | 0.2 mm ² ... 1.5 mm ² |
| Conductor cross section AWG/kcmil | 24 ... 12 | 24 ... 16 |
| Stripping length | 7 mm | 8 mm |
| Screw thread | M3 | |

Ambient conditions

| | |
|--|---|
| Ambient temperature (operation) | -20 °C ... 55 °C (observe derating) |
| Ambient temperature (storage/transport) | -40 °C ... 85 °C |
| Max. permissible relative humidity (operation) | 75 % (on average, 85% infrequently, non-condensing) |
| Max. permissible humidity (storage/transport) | 75 % (on average, 85% infrequently, non-condensing) |
| Maximum altitude | max. 2000 m (Above sea level) |
| Shock | 15g |
| Vibration (operation) | 10 Hz ... 150 Hz, 2g |

Conformance/Approvals

Conformance CE-compliant

The full EC Declaration of Conformity can be downloaded for the product at phoenixcontact.net/products.

Approvals 

Safety data

Stop category according to IEC 60204 0

Safety parameters for IEC 61508 - High demand

| | |
|---------------------|---|
| SIL | 3 (4 A DC13; 5 A AC15; 17520 switching cycles/year) |
| PFH _D | 5.79 x 10 ⁻⁸ (4 A DC13; 5 A AC15; 17520 switching cycles/year) |
| Demand rate | < 12 Months |
| Proof test interval | 240 Months |
| Duration of use | 240 Months |

Safety characteristic data according to EN ISO 13849

Category 3
Performance level e (4 A DC13; 5 A AC15; 17520 switching cycles/year)

For applications in PL e, the required demand rate for the safety function is once per month.

Safety parameters for EN 62061

SILCL 3 (4 A DC13; 5 A AC15; 17520 switching cycles/year)

5 Safety regulations and installation notes



WARNING: Death, serious personal injury or damage to equipment

Depending on the application, incorrect handling of the device may pose serious risks for the user or cause damage to equipment.

- Observe all the safety notes and warning instructions provided in this chapter and elsewhere in this document.

General

- Observe the safety regulations of electrical engineering and industrial safety and liability associations.

Disregarding these safety regulations may result in death, serious personal injury or damage to equipment.

Power supply units for 24 V supply

- Only use power supply units with safe isolation and SELV/PELV according to EN 50178/VDE 0160.
- Provide external protection for the 24 V area.
- Make sure that the power supply unit is able to supply **four times** the nominal current of the external fuse, to ensure that it trips in the event of an error.

Startup, mounting, and modifications

Startup, mounting, modifications, and upgrades may only be carried out by an electrically skilled person.

- Before working on the device, disconnect the power.
- Carry out wiring according to the application. Refer to the “Application examples” section for this.

Reliable operation is only ensured if the device is installed in housing protected from dust and humidity.

- Install the device in housing protected from dust and humidity (min. IP54).

In operation

During operation, parts of electrical switching devices carry hazardous voltages.

- Protective covers must not be removed when operating electrical switching devices.

For emergency stop applications, automatic startup of the machine can pose serious risks for the user.

- The machine must be prevented from restarting automatically by a higher-level controller.

Inductive loads can lead to welded relay contacts.

- Connect a suitable and effective protective circuit to inductive loads.
- Implement the protective circuit parallel to the load and not parallel to the switch contact.

Magnetic fields can influence the device. The magnetic field strength of the environment must not exceed 30 A/m.

- Do not use the device in the vicinity of strong magnetic fields (e.g., caused by transformers or magnetic iron).

Noise emission may occur when operating relay modules. Wireless reception may be disrupted in residential areas.

The device is a Class A product.

- Observe the requirements for noise emission for electrical and electronic equipment (EN 61000-6-4).
- Implement appropriate precautions against noise emission.

Surge voltages can destroy the device.

- Make sure that the output voltage of the voltage supply does not exceed 32 V even in the event of error.

Faulty devices

The devices may be damaged following an error. Correct operation can no longer be ensured.

- In the event of an error, replace the device.

Only the manufacturer or their authorized representative may perform the following activities. Otherwise the warranty is invalidated.

- Repairs to the device
- Opening the housing

Taking out of service and disposal

- Dispose of the device in accordance with environmental regulations.
- Make sure that the device can never be reused.

6 Function description

6.1 Two-channel evaluation

The two-channel evaluation unit of the safety relay module measures the residual voltage generated by the motor winding (measurement inputs L1, L2, L3) and evaluates it based on the switching threshold set for zero-speed.

6.2 Switching Threshold

The switching threshold, which can be set in 15 levels, consists of a lower value (switch-on threshold U_{on}) and an upper value (switch-off threshold U_{off}) for every increment. If the set switch-on threshold is undershot, the enabling current path (13/14) of the safety relay module closes after the set delay time (t_d) has elapsed.

If the measured residual voltage rises above the set switch-off threshold due to the motor switching on or moving, the enabling current path (13/14) opens without delay.

6.3 Switch-on delay

The switch-on delay is set in 15 levels (min. 0.5 s, max. 20 s) and takes effect when the parameterized switch-on threshold for zero-speed is undershot.



See "Function and time diagrams".
See "Parameterization".

6.4 Safety function

If the zero-speed safety relay detects a movement or error, the enabling current path opens and the device enters the safe state (path 13/14 open).

A safety function, such as unlocking or locking guard locking, can be executed via the enabling current path.

6.5 Error detection

Monitoring for internal and external errors is performed during operation. As soon as an error is detected, the device enters the safe state.



See "Error messages".

6.6 Operation on frequency inverters

Operation on adjustable speed electrical power drive systems (frequency inverters) is possible when the following provisions are observed.



WARNING: Standard operation

Safe operation cannot be ensured at excessively high output frequencies.

- Make sure that the 32 kHz output frequency of the drive (PWM) is not exceeded.



NOTE: Electromagnetic interference

Using shielded measuring lines is one possible way of countering electromagnetic interference.

- Observe the EMC installation measures of the frequency inverter manufacturer.



The safety relay module detects zero-speed only when a control inhibit is disabled/there is no position control.

6.7 Use of DC brakes



Note the following device behavior:

If braking is by means of a DC brake, the safety relay module diagnoses an open circuit error during DC supply (PWR LED lights up orange).

After switching off the braking voltage at standstill and after the set switch-on delay has elapsed, the error state is automatically reset and the device is ready for operation (PWR LED lights up green).

See "Function and time diagrams".

6.8 Operation on DC motors

Zero-speed monitoring of DC motors is possible with the safety relay module, provided a residual voltage is generated when run down.

Connection is the same as for single-phase AC motors.



Note the following device behavior:

The PWR LED lights up orange throughout DC operation. After switching off the DC motor voltage, zero-speed detection, and after the set switch-on delay has elapsed, the PWR LED lights up green.

6.9 Operation on motors with star-delta or pole changeover

Operation on motors with star-delta or pole changeover is possible when the following measures are observed.

- Make sure that measurement inputs L1, L2, and L3 are always directly connected to the monitored drive and that the connection is not interrupted when the motor is shut down, e.g., by switch contacts.



In the absence of a permanent connection between the measurement inputs and the monitored drive, the safety relay module diagnoses an open circuit and enters the safe state.

Option 1:

In the case of star-delta changeover, a permanent connection can be achieved between the measurement inputs and motor windings, for example, by enabling the star contactor at standstill.

Option 2:

Alternatively, a permanent connection can be achieved whereby the safety relay module between two phases is directly connected to one of the motor windings.

Proceed as follows:

- Bridge measuring lines L1 and L3 at the safety relay module.
- Connect bridged measuring lines L1/L3 to a motor winding.
- Connect measuring line L2 to the other end of the same motor winding.



WARNING: Loss of functional safety!

When you switch to option 2, your safety evaluation is no longer valid.

- Perform another safety evaluation for the connection to just one motor winding.
- Also refer to the notes for the "Downtime monitoring 1-phase motor" application example.

7 Function and time diagrams

7.1 Normal operation

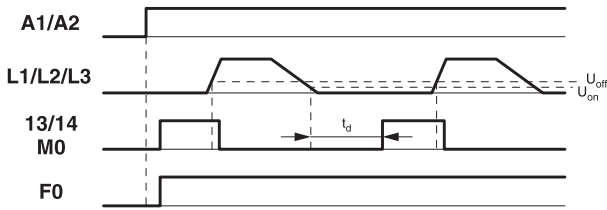

Figure 1 Time diagram, normal operation

7.2 Fault

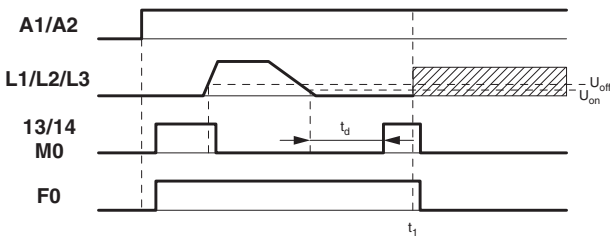

Figure 2 Time diagram, error

7.3 Open circuit error



In the event of an open circuit error, the device starts automatically once the error has been removed.

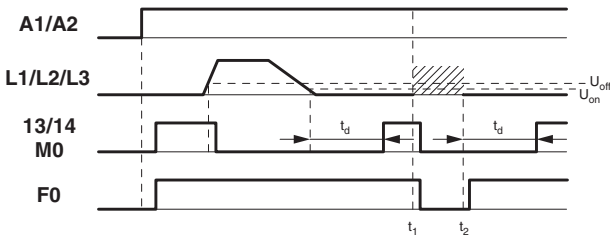

Figure 3 Time diagram, error open circuit

Key:

- t_d Switch-on delay (t_d)
- U_{off} Switch-off threshold (U_{off}) *
- U_{on} Switch-on threshold (U_{on}) *
- t_1 Time of the error
- t_2 Error removed

8 Basic circuit diagram

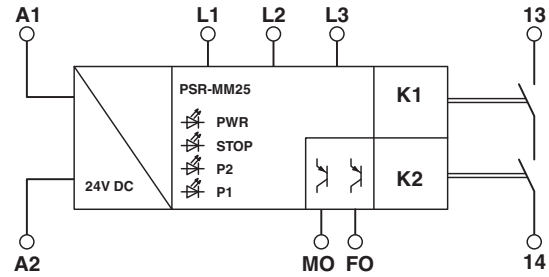

Figure 4 Block diagram

Key:

- A1** +24 V power supply
- A2** 0 V power supply
- L1, L2, L3** Measuring inputs
- MO** Signal output (PNP)
- FO** Error message output (PNP)
- 13/14** Enabling current path



Make sure that measurement inputs L1 - L3 are permanently connected to the motor windings.



Digital signal outputs MO and FO are **not** safe. These outputs should only be used to transmit the status.

9 Derating

9.1 Horizontal mounting position

The derating curve applies for the following conditions:

- Mounting on a horizontal DIN rail
- Devices mounted next to each other without spacing

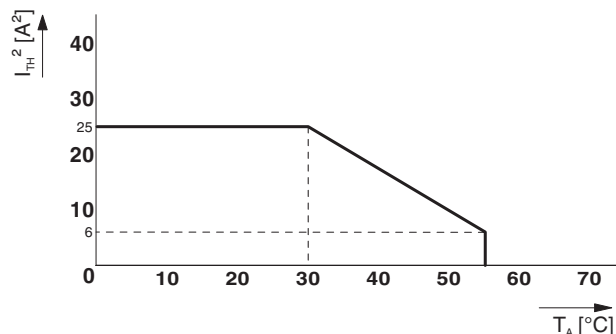

Figure 5 Derating curve - horizontal mounting position, without spacing

9.2 Vertical mounting position

The derating curve applies for the following conditions:

- Mounting on a vertical DIN rail
- Devices mounted next to each other without spacing

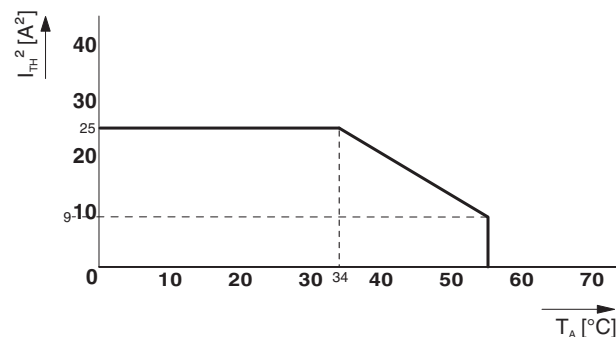

Figure 6 Derating curve - vertical mounting position, without spacing

10 Load curve

10.1 Ohmic and inductive load

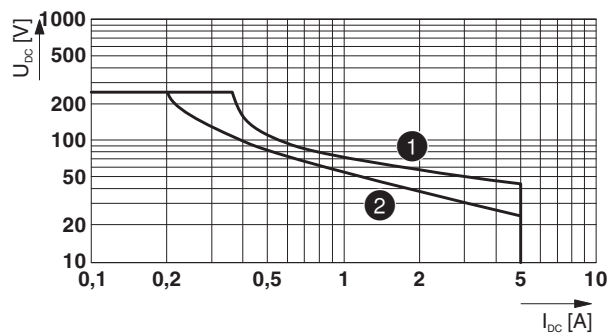

Figure 7 Relay load curve - ohmic and inductive load

Key:

- ① Ohmic load $L/R = 0$ ms
- ② Inductive load $L/R = 40$ ms

11 Operating and indication elements

11.1 Connection versions

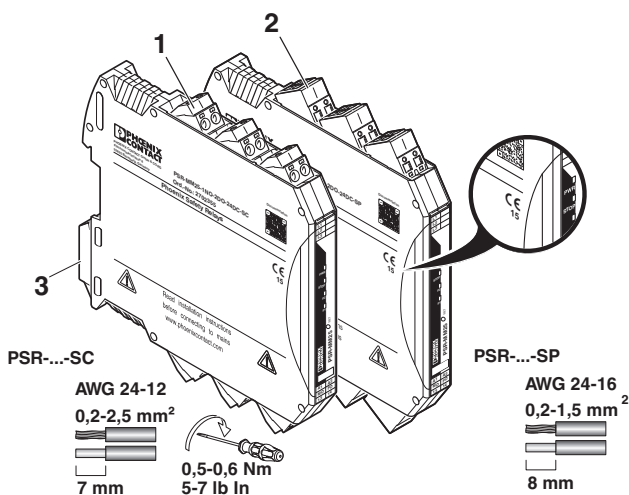

- 1 COMBICON plug-in screw terminal block
- 2 COMBICON plug-in spring-cage terminal block
- 3 Metal lock for fixing to DIN rail



The year the device was constructed can be found underneath the CE designation on the housing.

Figure 8 Connection versions

11.2 Connection assignment

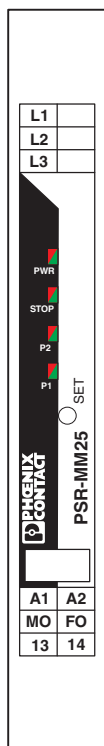

- L1, L2, L3** Measuring inputs
- PWR** Power LED (red, green)
- STOP** LED (red, green) - status of the safety function
- P2** LEDs (red, green) - parameterization
- P1** LEDs (red, green) - parameterization
- SET** SET button for parameterization
- A1** +24 V power supply
- A2** 0 V power supply
- MO** Signal output (PNP)
- FO** Error message output (PNP)
- 13/14** Enabling current path

12 Mounting and removing

- Mount the device on a 35 mm DIN rail according to EN 60715.
- To remove the device, use a screwdriver to release the snap-on foot.

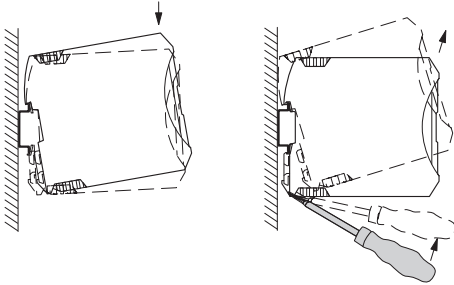

Figure 9 Mounting and removing

13 Wiring

- Connect the cables to the connection terminal blocks using a screwdriver.

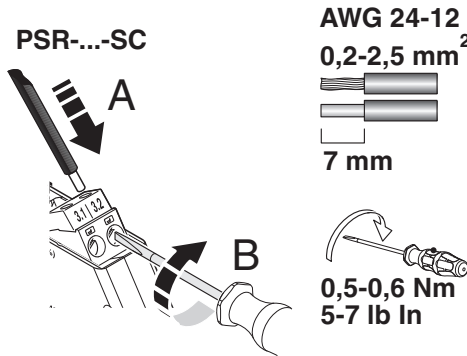

Figure 10 Connecting the cables for PSR-...-SC (screw terminal block)

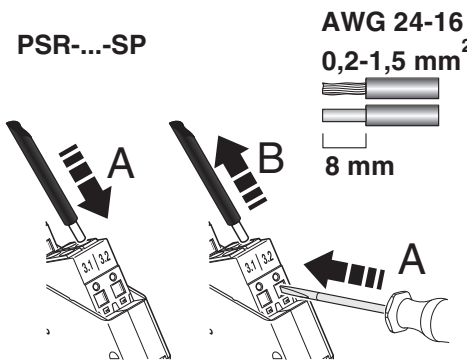

Figure 11 Connecting the cables for PSR-...-SC (spring-cage terminal block)



It is recommended that ferrules are used to connect stranded cables.



For compliance with UL approval, use copper wire that is approved up to 60°C/75°C.

13.1 Arrangement of the measuring lines



Observe the provisions of EN 60204-1 regarding the options and conditions for the connection of the safety relay module to the motor phases as well as for the arrangement of overcurrent protection equipment.

The conditions that must be met include the following:

- The conductor cross section of the measuring lines must be at least 1.5 mm².
- A parallel load on the measuring lines to the safety relay module is not permitted.
- The measuring lines should be installed so that the possibility of a cross-circuit or short circuit is reduced, e.g., the lines are protected by a cable duct or they are only installed inside the same mounting frame.
- If the conductor cross section is reduced, the section of the conductor that runs between the point where the current carrying capacity is reduced and the safety relay module must not be longer than 3 m.

13.2 Cabling aids

Suitable connectors for directly connecting the measurement inputs to the motor terminal board of the drive can be found at phoenixcontact.net/products.

A selection of insulated and uninsulated connectors can be found in the "Ordering data" section.



Observe the applicable installation instructions of the motor manufacturer.

14 Startup

- Apply the rated control circuit supply voltage (24 V DC) at terminal blocks A1/A2.

A selftest is performed.

Following successful completion of the selftest, the device is ready for operation when the PWR LED lights up green.

If a valid parameterization is already present on the device, the STOP LED also lights up green.

15 Parameterization

15.1 Important information on parameterization



WARNING: Risk of electric shock

Use a VDE-insulated screwdriver according to EN 60900 to press the SET button.



WARNING: Danger due to unexpected movement

The switching threshold and switch-on delay must be set correctly in order to ensure safe operation; this responsibility lies with the user.

- With the settings you make, you must make sure that the movement cannot present any danger.
- Specify the correct setting based on appropriate tests under worst-case conditions.
- Document the values set.



A new parameter setting is **not** saved if the operating voltage is interrupted during setup mode or if the SET button is not pressed for 20 s. The old parameter setting remains active.

When setup mode is active, the safety function and error monitoring are active in the background.

15.2 Preparation

Make sure the following preparations are made for parameterization:

- No one is present in the danger zone for the machine.
- The safety relay module is connected according to the specifications and the measurement inputs (L1, L2, L3) are constantly connected to the monitored motor.
- The monitored motor is at standstill.
- The power supply of the safety relay module (A1/A2) is switched on.
- The selftest is completed without errors and the PWR LED is green.

15.3 Displaying the currently set switching threshold

- Press the SET button for around **3 s** until all the LEDs are flashing **red**.
- Release the button. The LEDs flash according to the set parameter level.



You are now in setup mode. Briefly press the SET button again to adjust the parameter level.

- Press the SET button for around **2 s** to save the set parameter level and exit setup mode.

15.4 Displaying the currently set switch-on delay

- Press the SET button for around **6 s** until all the LEDs are flashing **green**.
- Release the button. The LEDs flash according to the set parameter level.



You are now in setup mode. Briefly press the SET button again to adjust the parameter level.

- Press the SET button for around **2 s** to save the set parameter level and exit setup mode.

15.5 Setting the switching threshold

The switching threshold should be set in 15 predefined parameter levels using the SET button on the device (see table).

The required switching threshold depends on the residual voltage generated on motor run down and is adapted to the monitored motor by means of the different parameter levels.

1. Press the SET button for around **3 s** until all the LEDs are flashing **red**.
2. Release the button. The LEDs flash according to the set parameter level.
3. Make sure that a low parameter level is set for the switching threshold (default upon delivery: 80 mV).
4. Change the parameter level by briefly pressing the SET button. Each press of the button sets the next level up.
5. If the STOP LED does not light up green after the set switch-on delay has elapsed, incrementally increase the switching threshold (parameter level 1 ... 2 ... 3 ...) until the STOP LED lights up green.
6. Press the SET button for around **2 s** to save the set parameter level and exit setup mode.

| Parameter level | 1 | 2 | 3 | 4 | 5 | 6 | 7 | 8 | 9 | 10 | 11 | 12 | 13 | 14 | 15 |
|-------------------------------------|--------|--------|--------|--------|--------|--------|--------|---------|---------|---------|---------|---------|---------|---------|---------|
| PWR LED | ● | ● | ● | ● | ● | ● | ● | ☼ | ☼ | ☼ | ☼ | ☼ | ☼ | ☼ | ☼ |
| STOP LED | ☼ | ☼ | ☼ | ☼ | ☼ | ☼ | ☼ | ● | ● | ● | ● | ☼ | ☼ | ☼ | ☼ |
| P2 LED | ● | ☼ | ☼ | ● | ● | ☼ | ☼ | ● | ● | ☼ | ☼ | ● | ● | ☼ | ☼ |
| P1 LED | ☼ | ● | ☼ | ● | ☼ | ● | ☼ | ● | ☼ | ● | ☼ | ● | ☼ | ● | ☼ |
| Switch-on threshold (U_{on})* | 50 mV | 55 mV | 60 mV | 65 mV | 70 mV | 75 mV | 80 mV | 200 mV | 230 mV | 250 mV | 300 mV | 350 mV | 400 mV | 460 mV | 500 mV |
| Switch-off threshold (U_{off})* | 120 mV | 120 mV | 120 mV | 120 mV | 120 mV | 120 mV | 120 mV | 1000 mV | 1000 mV | 1000 mV | 1000 mV | 1000 mV | 1000 mV | 1000 mV | 1000 mV |

*) Peak-to-peak voltage

Key:

- ☼ = LED flashing red
- = LED OFF



See "Function and time diagrams".

15.6 Set switch-on delay

After the parameterized switching threshold is undershot, the switch-on delay is applied for the enabling current path in order to implement an additional waiting time for motors that gradually coast to an actual standstill.

The minimum value to be set is 0.5 s. Switch-on can be delayed by a maximum of 20 s.

The switch-on delay should be set in 15 predefined parameter levels using the SET button on the device (see table).

1. Switch the motor on.

The STOP LED goes out, the enabling current path (13/14) and the signal output (MO) switch off.

2. Switch the motor off.

The switch-on delay is active, the STOP LED flashes green (default upon delivery: 1 s).

3. Determine the time the motor actually needs to run down.
4. Press the SET button for around **6 s** until all the LEDs are flashing **green**.
5. Release the button. The LEDs flash according to the set parameter level.

6. Select the desired parameter level by briefly pressing the SET button. Each press of the button sets the next level up.
7. Press the SET button for around **2 s** to save the set parameter level and exit setup mode.

When the motor has run down, the STOP LED lights up green (standstill) and both the enabling current path (13/14) and the signal output (MO) are active.



If the motor has not come to a standstill after the set switch-on delay has elapsed, optimize the settings for switching threshold and switch-on delay.



WARNING: Danger due to incorrect setting.

An incorrect parameterization can result in dangerous machine or system states.

- Check the parameterization before starting up for the first time.

| Parameter level | 1 | 2 | 3 | 4 | 5 | 6 | 7 | 8 | 9 | 10 | 11 | 12 | 13 | 14 | 15 |
|-----------------------------------|-------|-----|-----|-----|-----|-----|-----|-----|-----|------|------|------|------|------|------|
| PWR LED | ● | ● | ● | ● | ● | ● | ● | ☀ | ☀ | ☀ | ☀ | ☀ | ☀ | ☀ | ☀ |
| STOP LED | ☀ | ☀ | ☀ | ☀ | ☀ | ☀ | ☀ | ● | ● | ● | ● | ☀ | ☀ | ☀ | ☀ |
| P2 LED | ● | ☀ | ☀ | ● | ● | ☀ | ☀ | ● | ● | ☀ | ☀ | ● | ● | ☀ | ☀ |
| P1 LED | ☀ | ● | ☀ | ● | ☀ | ● | ☀ | ● | ☀ | ● | ☀ | ● | ☀ | ● | ☀ |
| Switch-on delay (t _d) | 0,5 s | 1 s | 2 s | 3 s | 4 s | 5 s | 6 s | 7 s | 8 s | 10 s | 12 s | 14 s | 16 s | 18 s | 20 s |

Key:



= LED flashing green



= LED OFF



See "Function and time diagrams".

16 Diagnostics

The following section describes the LED indicators for general states and error messages as well as the possible status of the digital signal outputs.

Function test



Use the function test to check the safety function. To do this, request the safety function once by allowing the monitored motor to start up. The outputs of the device switch off. Then allow the motor to run down. Once the motor has reached a standstill and after the set delay time has elapsed, the outputs switch on.

See "Startup".

16.1 General states

| PWR-LED | STOP-LED | P1-LED | P2-LED | State | |
|----------|----------------|--------|--------|-----------------|---|
| Green ON | Green ON | OFF | OFF | Standstill | The device is ready for operation after completing a selftest without errors or after a switch-on delay has elapsed. The enabling current path is closed. |
| Green ON | OFF | OFF | OFF | Movement | A movement has been detected. The enabling current path is open (safe state). |
| | | | | Standstill | The device enters the safe state even though the motor is at a standstill. <u>Remedy:</u> ensure that there are no residual voltages (induced voltages or drives that are in position control). Parameterize the switching threshold during the startup phase (see "Setting the switching threshold"). |
| Green ON | Green flashing | OFF | OFF | Motor runs down | The set switching threshold has already been undershot and the set switch-on delay is running. The enabling current path is open for the duration of the switch-on delay (safe state). |

16.2 Status of the signal outputs



The device and operating status can be transmitted to a higher-level controller via the digital signal outputs.

| MO | FO | Device | Motor |
|------|------|--------|--------------|
| 24 V | 24 V | OK | Standstill |
| 0 V | 24 V | OK | Movement |
| 0 V | 0 V | Not OK | No influence |

16.3 Error Messages

The flashing red PWR LED indicates an error state.

Refer to the figure for the detailed blink behavior of the red PWR LED in the event of different error causes.

See ❶ - ❺ in the table and figure.

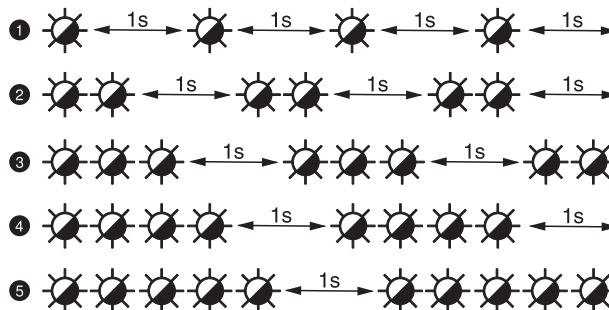

Figure 12 Blink behavior of the PWR LED (red)

| PWR-LED | | STOP-LED | P1-LED | P2-LED | State | Possible cause | Corrective |
|--------------|---|----------|--------|--------|----------------|---|---|
| Flashing red | ❶ | OFF | OFF | OFF | Internal error | - | 1. Ensure that there is no external error. 2. Acknowledge the internal error by switching the device off and then on again. If the error still occurs, replace the device. |
| | ❸ | | | | | | |
| Flashing red | ❺ | OFF | OFF | OFF | External error | Impermissible operating voltage / operating voltage outside the tolerance range | Check the operating voltage and control the operating voltage so that it is within the permissible range. |
| | ❷ | | | | | | |
| Flashing red | ❹ | OFF | OFF | OFF | External error | Single-channel signal at the measuring lines (simultaneity failure) | Check the connection of the device for cross or short circuit. |
| | | | | | No error | Sustained signal difference (simultaneity failure) > 10 s due to gradual motor run down | Connect the motor lines between two phases directly to one of the motor windings. To do this, connect L1 and L3 (bridged) to one end of a winding and L2 to the other end of the same motor winding (see "Operation on motors with star-delta or pole changeover"). |
| Orange on | - | OFF | OFF | OFF | External error | Open circuit at the measuring lines | Check the connection of the device for cross or short circuit. |
| | | | | | No error | Operation on DC motors or DC brakes | No action required. The error message will be reset automatically after DC shutdown. |

17 Application examples

17.1 Zero-speed monitoring 1-phase motor

- 1-phase motor
- Interlocking device with guard locking
- PSR-MM25: zero-speed monitoring, control/release of guard locking
- PSR-MC30: safety door monitoring
- Error prevention required:
 - on mechanical parts of guard locking
 - for cross-circuits in the control for guard locking
- Suitable up to category 1, PL c (EN ISO 13849-1), SIL 1 (EN 62061)

Key:

- S1** Unlock button (release of guard locking)
- S2** Manual reset device
- E1/E2** Guard locking
- B1** Interlocking device
- K1 ... K4** Force-guided contactors



If error prevention for achieving the safety integrity is required, implement according to EN ISO 13849-2, Annex D.

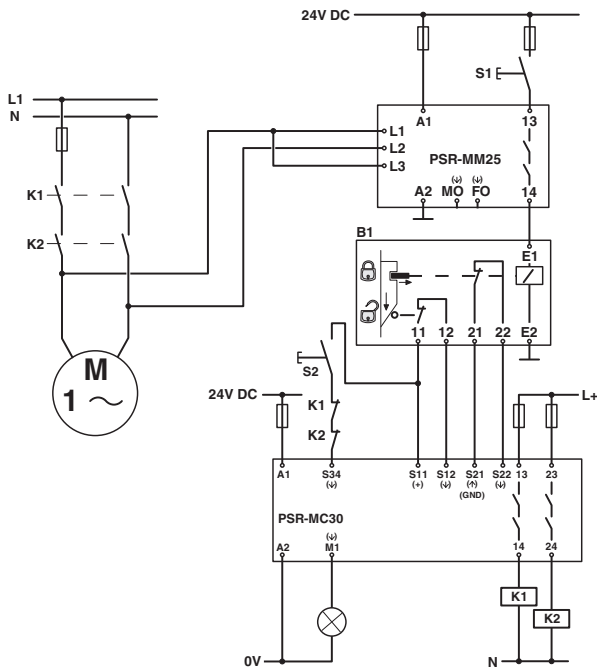

Figure 13 Zero-speed monitoring 1-phase motor

If motor faults (e.g., interturn fault) are taken into consideration and appropriate measures are taken, the following alternative safety ratings are possible for the application.

Alternative safety rating and measure:

- Higher-level motor protection as test equipment for early detection of a motor fault (suitable overcurrent and overtemperature protection)
- Suitable up to category 2, PL d (EN ISO 13849-1), SIL 2 (EN 62061)

Alternative safety rating and measure:

- A motor fault is taken into consideration by preventatively reducing the switch-on threshold (U_{on}) or increasing the switch-on delay (t_d) depending on the risk assessment
- Suitable up to category 3, PL d (EN ISO 13849-1), SIL 2 (EN 62061)

Alternative safety rating and measure:

- Prevention of motor faults which lead to a reduction in the inductance and therefore reduce the residual voltage
- Suitable up to category 3, PL d (EN ISO 13849-1), SIL 2 (EN 62061)

17.2 Zero-speed monitoring 3-phase motor

- 3-phase motor
- Interlocking device with guard locking
- PSR-MM25: zero-speed monitoring, control/release of guard locking
- PSR-MC30: safety door monitoring
- Error prevention required:
 - on mechanical parts of guard locking
 - for cross-circuits in the control for guard locking
- Suitable up to category 3, PL d (EN ISO 13849-1), SIL 2 (EN 62061)

Key:

- S1** Unlock button (release of guard locking)
- S2** Manual reset device
- E1/E2** Guard locking
- B1** Interlocking device
- K1 ... K4** Force-guided contactors

 If error prevention for achieving the specified safety integrity is required, implement according to EN ISO 13849-2, Annex D.

 Make sure that measurement inputs L1 - L3 are permanently connected to the motor windings.
See "Operation on motors with star-delta or pole changeover".

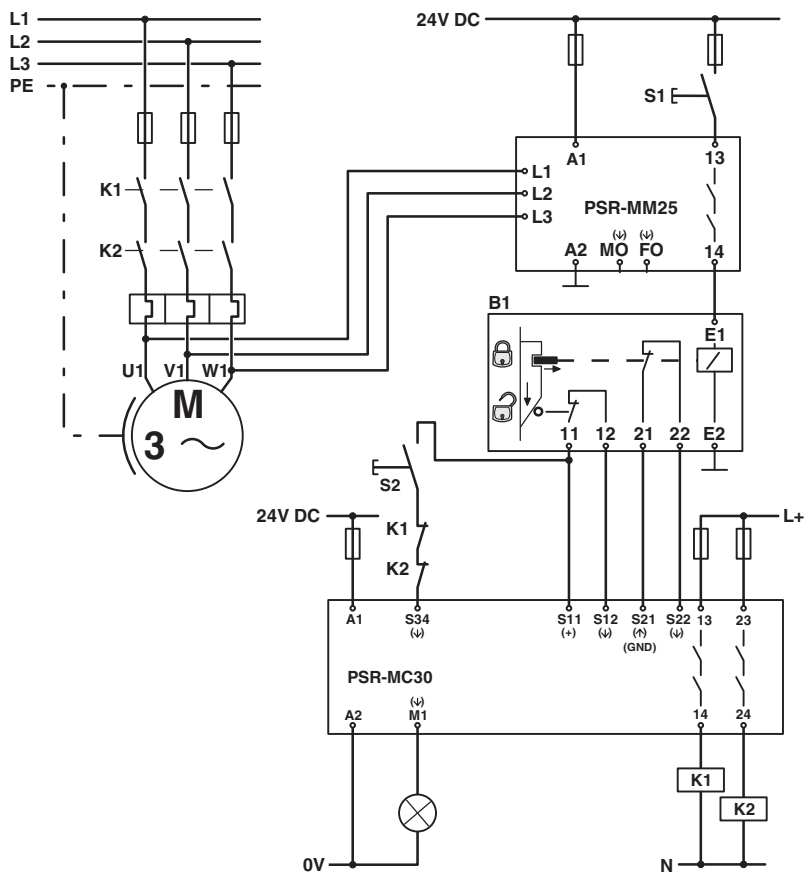

Figure 14 Zero-speed monitoring 3-phase motor

18 Attachment

18.1 Revision history

| Version | Date | Contents |
|---------|------------|--|
| 00 | 2015-12-11 | First publication, internal |
| 01 | 2016-02-16 | First publication |
| 02 | 2016-03-18 | Application example 17.2 modified |
| 03 | 2016-04-21 | Application example 17.1 modified |
| 04 | 2016-06-03 | Safety note added in Section 6.9; safety note in Section 15.1 revised; alternative safety ratings added for application example 17.1 |
| 05 | 2017-09-15 | Technical data: Values for rated insulation voltage and rated surge voltage / insulation amended; safety notes for 24 V supply amended |



SCATTERGOOD & JOHNSON LTD

ELECTRICAL ENGINEERING & FLUID CONTROL DISTRIBUTORS

Est.1899

At Scattergood & Johnson Ltd, we pride ourselves on being a technical distributor to specialist industries.

Working with a range of quality product suppliers across a number of specialist markets, we are not your average 'box shifter' - we are your technical and supply chain partner.

We fully support every product we sell - for free! Our internal team and external sales engineers can answer any product or application question, no matter the complexity.

Backing up this technical ability is a range of 50,000+ products available from stock for nationwide next day delivery (same day if required!), or you can collect what you need from any of our trade counters around the UK.

Select your specialist interest below to learn more about how we can help.

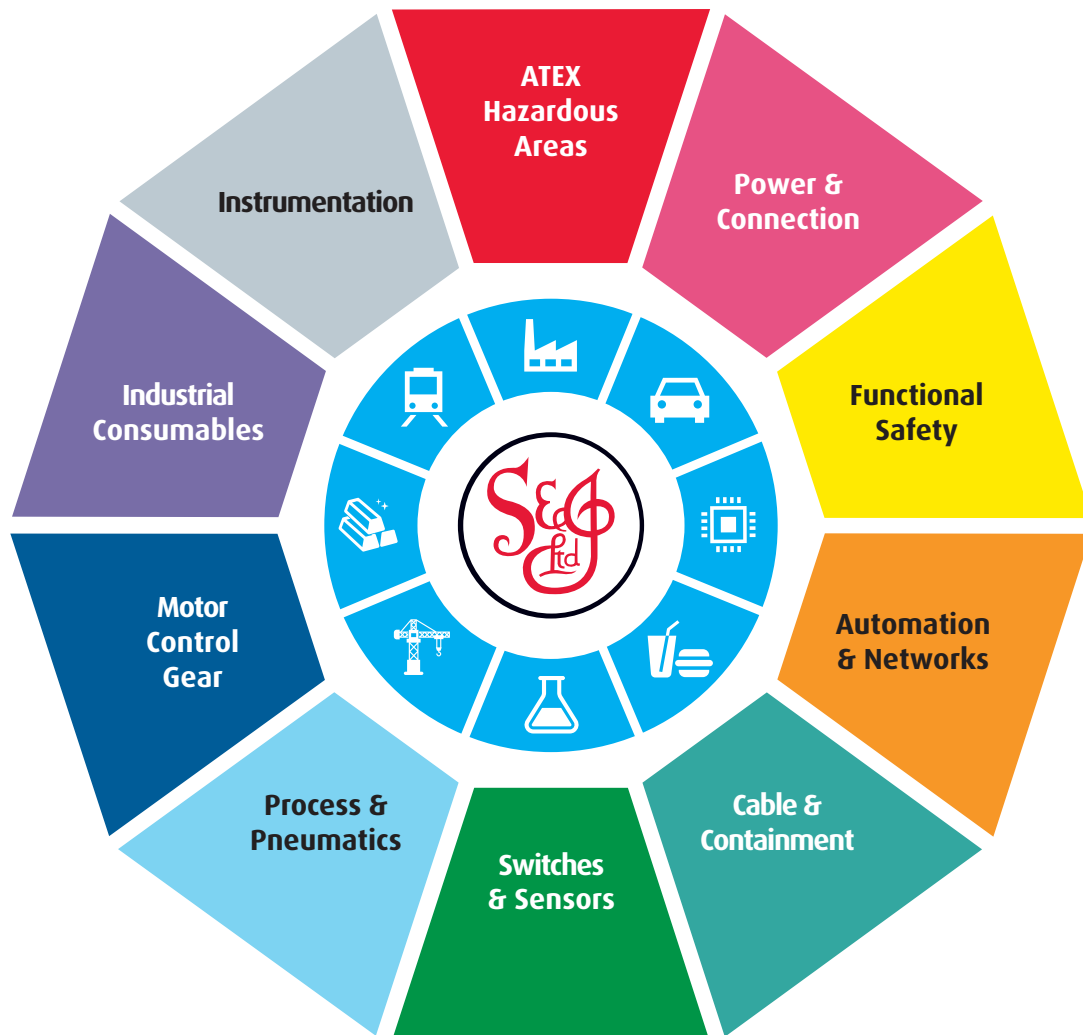

Online, In Branch and On the Road - Scattergood & Johnson Ltd, there when you need us.

www.scatts.co.uk