

MCR-VDC-UI-B-DC

Voltage transducer for DC voltages

INTERFACE

Data sheet
100260_en_02

© PHOENIX CONTACT 2010-01-27



1 Description

The MCR voltage transducer measures DC voltages in several signal ranges from 0 ... ±20 V DC to 0 ... ±660 V DC and converts them to standardized analog signals. DC voltages can be processed with both positive and negative polarity.

The input voltage ranges listed at input terminal blocks 1 to 7 can be varied by ±20% using a calibration potentiometer.

The voltage transducer is calibrated by default to 0 ... ±24 V input and 0 ... ±10 V output and is ready for operation when delivered. To use the device with other input or output variables, carry out a ZERO/SPAN adjustment using the potentiometers on the front.

1.1 Features

- 3-way electrical isolation
- True r.m.s. value measurement
- Adjustable voltage ranges
- ZERO/SPAN adjustment ±20%

1.2 Method of operation

The input circuit divides the DC voltage at terminal blocks 1 to 7. The resulting signal is electrically isolated and transmitted to the output circuit and is available at the output as a standardized analog signal.

1.3 Field of application

When using the voltage transducer, please ensure that the potential difference between terminal blocks 1 to 7 to ground potential PE or terminal block 8 to ground potential PE U does not exceed ±660 V (this condition applies to circuits that are not grounded).

In DC voltage networks, this potential difference must not exceed $U = \pm 100$ V (this condition applies to circuits that are grounded).

When these conditions are met, **safe isolation** is ensured between the input, output, and power supply.



Make sure you always use the latest documentation.
It can be downloaded at www.phoenixcontact.net/catalog.



This data sheet is valid for all products listed on the following page:

2 Table of contents

1	Description.....	1
1.1	Features	1
1.2	Method of operation	1
1.3	Field of application	1
2	Table of contents	2
3	Ordering data.....	3
4	Technical data	3
5	Block diagram.....	5
6	Safety notes	5
7	Structure	5
8	Installation	6
9	Configuration	6
9.1	Selecting the input voltage range	6
9.2	Opening the module	7
9.3	Jumper settings.....	7
10	ZERO/SPAN adjustment	7
10.1	Zero point adjustment (ZERO)	7
10.2	Final value adjustment (SPAN).....	7

3 Ordering data

Description	Type	Order No.	Pcs./Pkt.
MCR voltage transducer, for DC voltages from 0 ... ± 20 V DC to 0 ... ± 660 V DC, output signal ± 10 V/ ± 20 mA	MCR-VDC-UI-B-DC	2811116	1

4 Technical data

Voltage measuring input	
Input voltage range (input resistance)	± 550 V DC (550 k Ω) ± 370 V DC (370 k Ω) ± 250 V DC (250 k Ω) ± 170 V DC (170 k Ω) ± 120 V DC (120 k Ω) ± 80 V DC (80 k Ω) ± 54 V DC (54 k Ω) ± 36 V DC (36 k Ω) ± 24 V DC (24 k Ω)
Maximum input voltage	± 660 V DC (not grounded) ± 100 V DC (to ground)



When these values are observed, safe isolation (EN 50178/DIN EN 50178/VDE 0160) is ensured between the input, output, and power supply.

Voltage output	
Voltage output signal	-10 V ... 10 V
Maximum voltage output signal	± 15 V
Load/output load voltage output	> 10 k Ω
Ripple	< 50 mV _{PP}

Current output	
Current output signal	-20 mA ... 20 mA
Maximum current output signal	± 30 mA
Load/output load voltage output	< 500 Ω
Ripple	< 50 mV _{PP}

Power supply	
Supply voltage range	18.5 V DC ... 30.2 V DC
Maximum current consumption	< 50 mA

General data	
Limit frequency (3 dB)	40 Hz
Measuring principle	True r.m.s. value measurement
Maximum transmission error	< 1% (of final value)
Maximum temperature coefficient	< 0.015%/K
Zero adjustment	$\pm 20\%$
Span adjustment	$\pm 20\%$
Step response (10 - 90%)	12 ms
Degree of protection	IP20

General data (continued)

Pollution degree	2
Width x height x length	22.5 mm x 99 mm x 114.5 mm
Housing version	Polyamide PA, non-reinforced, green

Connection data

Conductor cross-section, solid	0.2 mm ² ... 2.5 mm ²
Conductor cross-section, stranded	0.2 mm ² ... 2.5 mm ²
Stripping length	8 mm

Safe isolation according to EN 50178

Surge voltage category	II
Pollution degree	2
Input/output test voltage	1.5 kV (50 Hz, 1 min.)

Rated insulation voltage

Input/output	660 V DC, for ungrounded circuits 100 V DC, for grounded circuits
Output/power supply	50 V DC

Ambient conditions

Ambient temperature (operation)	-25°C ... +50°C
Ambient temperature (storage/transport)	-40°C ... +85°C, no condensation

Conformance/approvals

Conformance	CE-compliant
UL, USA/Canada	

Conformance with EMC Directive 89/336/EEC**Noise immunity according to EN 61000-6-2**

Electrostatic discharge	EN 61000-4-2	8 kV air discharge
Electromagnetic HF field	EN 61000-4-3	
Amplitude modulation		10 V/m
Pulse modulation		10 V/m
Fast transients (burst)	EN 61000-4-4	Input/output/power supply: 2 kV/5 kHz
Surge current loads (surge)	EN 61000-4-5	Input/output: 2 kV/42 Ω Power supply: 0.5 kV/2 Ω
Conducted interference	EN 61000-4-6	Input/output/power supply: 10 V

Noise emission according to EN 61000-6-4

Noise emission according to EN 61000-6-4	EN 55011	Class A
--	----------	---------

5 Block diagram

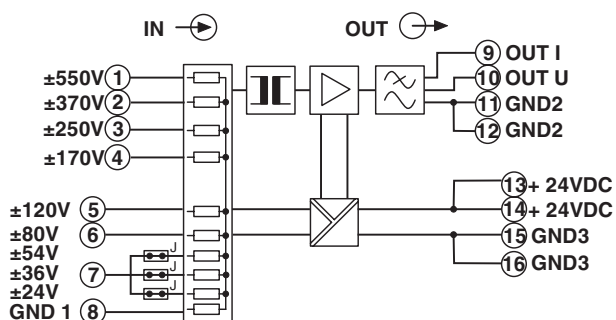

Figure 1 Block diagram for the MCR-VDC-UI-B-DC

6 Safety notes



CAUTION

Installation, operation, and maintenance may only be carried out by qualified electricians. When installing and operating the device, the applicable safety directives (including national safety directives), accident prevention regulations, as well as general technical regulations, must be observed.



CAUTION: Electrostatic discharge

The module contains components that can be damaged or destroyed by electrostatic discharge. When handling the module, observe the necessary safety precautions against electrostatic discharge (ESD) according to EN 61340-5-1 and EN 61340-5-2.

7 Structure

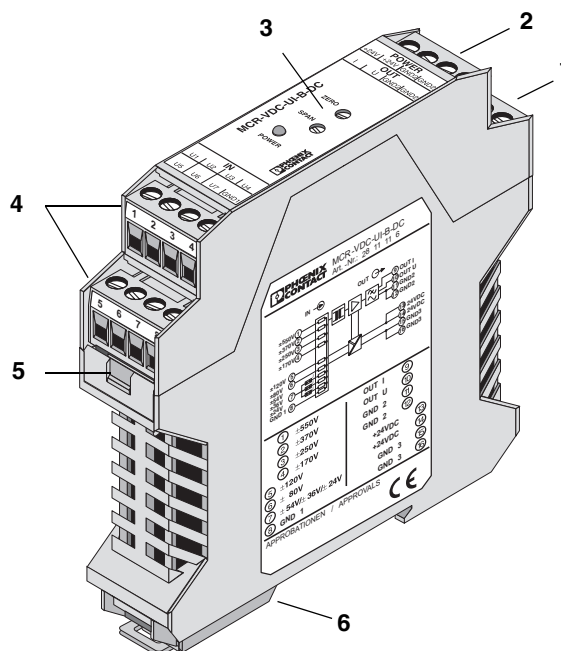

Figure 2 Location of the elements

- 1 Supply voltage
- 2 Output
- 3 Potentiometer for adjustment
- 4 Inputs
- 5 Upper part of the housing can be removed to set the jumpers
- 6 Universal snap-on foot for EN DIN rails

8 Installation

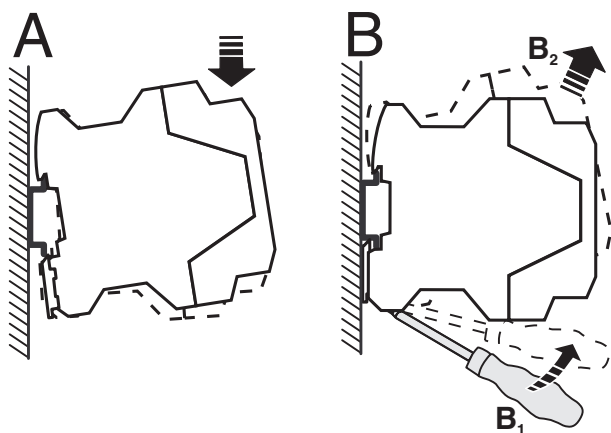

Figure 3 Mounting/removal

The assignment of the connection terminal blocks is shown in the block diagram. The module can be snapped onto all 35 mm DIN rails according to EN 60715.

Install the module in suitable housing to meet the requirements for the protection class.

Screw connection

Insert the wire into the corresponding connection terminal block.

Use a screwdriver to tighten the screw in the opening above the connection terminal block.

9 Configuration

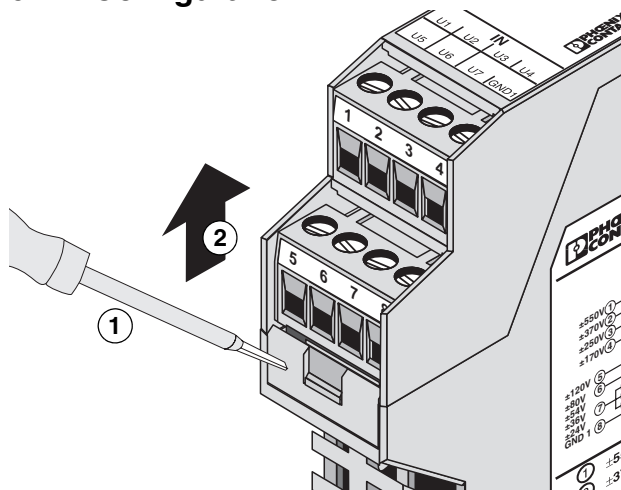

Figure 4 Opening the housing



WARNING: Risk of electric shock

Never carry out work when voltage is present.



NOTE: Module damage due to excess voltage

If the voltage signal exceeds the voltage range specified at the input signal terminal block by more than 15% (for 0 ... ±660 V by more than 5%), the input circuit may be damaged.

9.1 Selecting the input voltage range

Input voltage	Adjustment range (±2 %) [V DC]	Input terminal block	Jumper/setting
0 ... ±550 V	(440 ... 660)	1	
0 ... 370 V	(296 ... 444)	2	
0 ... 250 V	(200 ... 300)	3	
0 ... 170 V	(136 ... 204)	4	
0 ... 120 V	(96 ... 144)	5	
0 ... 80 V	(64 ... 96)	6	
0 ... 54 V	(43... 65)	7	J1/setting 1
0 ... 36 V	(28 ... 43)	7	J1/setting 2
0 ... 24 V	(19 ... 29)	7	J1/setting 3 (default setting)

9.2 Opening the module

- Using a screwdriver, release the locked upper part of the housing on both sides ①. The upper part of the housing and the electronics can now be pulled out approximately 3 cm ② (see Figure 4 on page 6).

9.3 Jumper settings

- Insert the jumper (J) in slot J1 ... J3 according to the required input voltage.

Input voltage:

Input	Position
54 V	J1
36 V	J2
24 V	J3

- Close the housing again until it engages with a click.



Carry out a ZERO/SPAN adjustment each time the input or output range is changed.

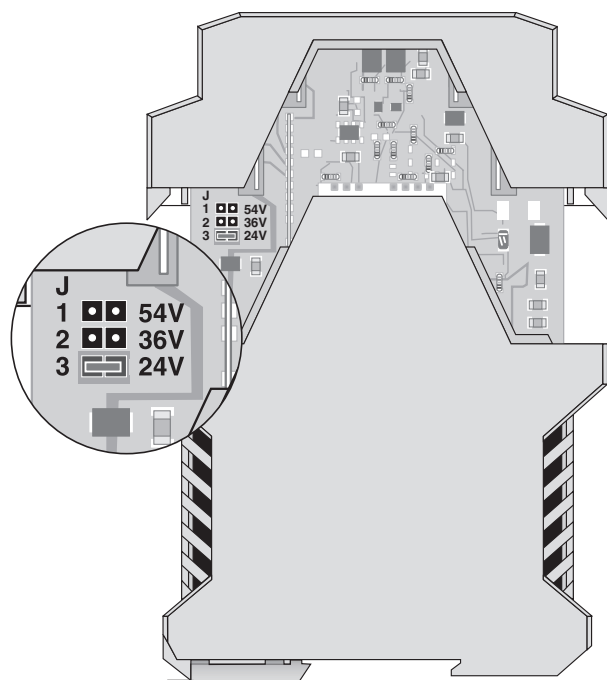

Figure 5 Location of the jumper (J)

10 ZERO/SPAN adjustment

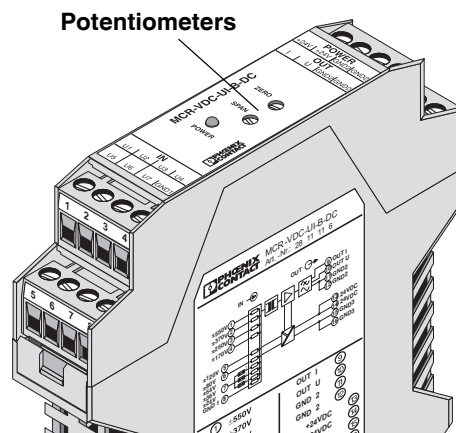

Figure 6 Location of the potentiometers



Allow the module to warm up for 4 minutes before starting the adjustment procedure.

The module is calibrated by default to 0 ... ±24 V input and 0 ... ±10 V output.

There are two potentiometers on the front of the module for the adjustment:

- ZERO: Zero point adjustment
- SPAN: Final value adjustment

10.1 Zero point adjustment (ZERO)

- Connect a calibration device to the input terminal blocks ($U_{(1-7)}$ and GND1) and specify a voltage of 0 mV.
- Set the output signal value using the ZERO potentiometer:
 - Voltage output (0 ... ±10 V): $U_{OUT} = 0$ V
 - Current output (0 ... ±20 mA): $I_{OUT} = 0$ mA

10.2 Final value adjustment (SPAN)

- Use the calibration device to specify the maximum voltage used within the input voltage range (see "Selecting the input voltage range" on page 6).
- Set the output signal value ($U_{OUT} = 10$ V or $I_{OUT} = 20$ mA) using the SPAN potentiometer.



SCATTERGOOD & JOHNSON LTD

ELECTRICAL ENGINEERING & FLUID CONTROL DISTRIBUTORS

Est.1899

At Scattergood & Johnson Ltd, we pride ourselves on being a technical distributor to specialist industries.

Working with a range of quality product suppliers across a number of specialist markets, we are not your average 'box shifter' - we are your technical and supply chain partner.

We fully support every product we sell - for free! Our internal team and external sales engineers can answer any product or application question, no matter the complexity.

Backing up this technical ability is a range of 50,000+ products available from stock for nationwide next day delivery (same day if required!), or you can collect what you need from any of our trade counters around the UK.

Select your specialist interest below to learn more about how we can help.



Online, In Branch and On the Road - Scattergood & Johnson Ltd, there when you need us.

www.scatts.co.uk