

MACX MCR-UI-UI-UP(-SP)(-NC)



Ex n



Configurable 3-way isolating amplifier with safe isolation and wide-range power supply

Data sheet
104247_en_02

© PHOENIX CONTACT 2013-04-08

1 Description

MACX MCR-UI-UI 3-way isolating amplifiers are used to electrically isolate and convert standard analog signals.

3-way isolation prevents interference between different sensor circuits and thus improves the quality of the measuring circuit.

DIP switches can be used to reconfigure the inputs and outputs of the isolating amplifier, enabling more than 1600 signal conversions to be set.

When ordering preconfigured modules, specify the desired input and output signal combination (see order key). If the information is incorrect or unavailable, the devices will be supplied with the standard configuration (0 ... 10 V input signal, 0 ... 20 mA output signal).

Features

- 3-way electrical isolation
- More than 1600 signal combinations can be set using DIP switches (no software required)
- Up to SIL 2 according to EN 61508 for the live zero output
- Installation in zone 2 permitted
- Wide-range power supply including tolerance of 19.2 ... 253 V AC/DC
- Step response (10 ... 90%) of 35 µs (at 10 kHz), 11 ms (at 30 Hz)
- With screw or spring-cage connection
- Active and passive output



WARNING: Explosion hazard

The device is designed for use in zone 2, if the specific conditions are observed. Observe the safety regulations and installation notes on page 6.

When installing and operating the device, the applicable safety directives (including national safety directives), accident prevention regulations, as well as general technical regulations, must be observed.

WARNING: Dangerous contact voltage

This work may only be carried out by qualified personnel who are familiar with the necessary safety precautions.



Make sure you always use the latest documentation. It can be downloaded at phoenixcontact.net/products.



This data sheet is valid for all products listed on the following pages:

2 Table of contents

1	Description.....	1
2	Table of contents	2
3	Ordering data.....	3
4	Order key	3
5	Technical data	4
6	Safety regulations and installation notes.....	6
6.1	Installation and operation	6
6.2	Safety regulations for installation in potentially explosive areas	6
6.3	Use in safety-related applications (SIL 2)	6
7	Installation	7
7.1	Block diagram	7
7.2	Structure.....	7
7.3	Dimensions	7
7.4	Mounting	8
7.5	Connecting the cables.....	8
7.6	Application examples	8
8	Configuration.....	9
8.1	Settings	9
8.2	Adjustment	9
8.3	Inverse characteristic curve (rising input signal, falling output signal).....	10
8.4	Configuration table	11
9	Safety-related applications (SIL 2).....	12
9.1	Safety function and safety requirements	12
9.2	Safety integrity requirements	13
9.3	Configuring a SIL device	14
9.4	Installation and startup	14
9.5	Notes on operation	14
9.6	Recurring checks (SIL 2)	14
9.7	Repair.....	15
9.8	Standards (SIL 2)	15
9.9	Abbreviations	15

3 Ordering data

Universal 3-way isolating amplifier

Description	Type	Order No.	Pcs./Pkt.
Universal 3-way isolating amplifier, for electrical isolation of analog signals with wide-range power supply, configured according to order key, with screw connection	MACX MCR-UI-UI-UP	2811459	1
Universal 3-way isolating amplifier, for electrical isolation of analog signals with wide-range power supply, standard configuration (0 ... 10 V input signal, 0 ... 20 mA output signal), with screw connection	MACX MCR-UI-UI-UP-NC	2811297	1
Universal 3-way isolating amplifier, for electrical isolation of analog signals with wide-range power supply, configured according to order key, with spring-cage connection	MACX MCR-UI-UI-UP-SP	2811585	1
Universal 3-way isolating amplifier, for electrical isolation of analog signals with wide-range power supply, standard configuration (0 ... 10 V input signal, 0 ... 20 mA output signal), with spring-cage connection	MACX MCR-UI-UI-UP-SP-NC	2811569	1

4 Order key

Order key for MACX MCR-UI-UI-... (standard configuration entered as an example)

Order No.	Input	Output	Limit frequency	Factory calibration certificate		
2811459	IN03	OUT01	10K	NONE		
2811459 ≙ ...UI-UI-UP	IN40 ≙ 0...50 mV IN24 ≙ 0...60 mV IN41 ≙ 0...75 mV IN25 ≙ 0...100 mV IN43 ≙ 0...120 mV IN44 ≙ 0...150 mV IN26 ≙ 0...200 mV IN27 ≙ 0...300 mV IN28 ≙ 0...500 mV IN66 ≙ 0...1000 mV IN29 ≙ 0...1.0 V IN50 ≙ 0...1.5 V IN30 ≙ 0...2.0 V IN52 ≙ 0...3.0 V IN05 ≙ 0...5 V IN03 ≙ 0...10 V IN67 ≙ 0...15 V IN32 ≙ 0...20 V IN39 ≙ 0...30 V IN68 ≙ 0...50 V IN69 ≙ 0...100 V IN06 ≙ 1...5 V IN04 ≙ 2...10 V	IN53 ≙ -50...+50 mV IN13 ≙ -60...+60 mV IN54 ≙ -75...+75 mV IN14 ≙ -100...+100 mV IN56 ≙ -120...+120 mV IN57 ≙ -150...+150 mV IN15 ≙ -200...+200 mV IN16 ≙ -300...+300 mV IN17 ≙ -500...+500 mV IN78 ≙ -1000...+1000 mV IN18 ≙ -1.0...+1.0 V IN63 ≙ -1.5...+1.5 V IN19 ≙ -2.0...+2.0 V IN65 ≙ -3.0...+3.0 V IN21 ≙ -5...+5 V IN22 ≙ -10...+10 V IN79 ≙ -15...+15 V IN23 ≙ -20...+20 V IN80 ≙ -30...+30 V IN81 ≙ -50...+50 V IN82 ≙ -100...+100 V IN91 ≙ 1...5 mA IN92 ≙ 2...10 mA IN02 ≙ 4...20 mA	OUT19 ≙ 0...2.5 V OUT05 ≙ 0...5 V OUT03 ≙ 0...10 V OUT20 ≙ -2.5...+2.5 V OUT13 ≙ -5...+5 V OUT14 ≙ -10...+10 V OUT24 ≙ 0.5...+2.5 V OUT06 ≙ 1...5 V OUT04 ≙ 2...10 V OUT27 ≙ 2.5...0 V OUT11 ≙ 5...0 V OUT09 ≙ 10...0 V	OUT15 ≙ 0...5 mA OUT16 ≙ 0...10 mA OUT01 ≙ 0...20 mA OUT21 ≙ -5...+5 mA OUT22 ≙ -10...+10 mA OUT23 ≙ -20...+20 mA OUT25 ≙ 1...5 mA OUT26 ≙ 2...10 mA OUT02 ≙ 4...20 mA OUT28 ≙ 5...0 mA OUT29 ≙ 10...0 mA OUT07 ≙ 20...0 mA	30 ≙ 30 Hz 10K ≙ 10 kHz	NONE NONE ≙ Without factory calibration certificate YES ≙ With factory calibration certificate (a fee is charged) YESPLUS ≙ Factory calibration certificate with 5 measuring points (a fee is charged)



Due to the wide range of configuration options, a configuration tool (for Excel) can be downloaded at phoenixcontact.net/products.

5 Technical data

Input		
Measuring input	U_{IN}	I_{IN}
Input signal	0 ... 10 V (for other input signals, see Section 8.4 "Configuration table")	
Maximum input signal		
Connection terminal block 4.1/5.2	30 V	200 mA
Connection terminal block 4.2/5.2	150 V	20 mA
Connection terminal block 5.1/5.2		
Input resistance	100 k Ω (± 50 ... ± 1000 mV DC) 1 M Ω (± 1 ... ± 100 V DC)	100 Ω (± 1 ... ± 5 mA) 10 Ω (± 10 ... ± 100 mA DC)
Output		
Measuring output	U_{OUT}	I_{OUT}
Output signal	0 ... 20 mA (for other input signals, see Section 8.4 "Configuration table")	
Maximum output signal	± 15 V DC	± 30 mA DC
Load	≥ 1 k Ω (10 V)	Active: ≤ 600 Ω (20 mA) Passive: $\leq U_B - 2 V / I_{OUTmax}$
General data		
Supply voltage U_B	24 ... 230 V AC/DC (-20 ... +10%, 50 Hz/60 Hz)	
Power dissipation at 24 V DC/230 V AC	< 0.8 W/< 0.9 VA (20 mA)	
Accuracy		
Adjusted (full scale)	< 0.1%	
DIP switch position without adjustment	< 0.4%	
Temperature coefficient	0.0075%/K	
Limit frequency (3 dB)	30 Hz/10 kHz (can be selected)	
Step response (10 ... 90%)	35 μ s (at 10 kHz) 11 ms (at 30 Hz)	
Electrical isolation	3-way, between input/output/power supply	
Input/output/power supply (test voltage)	300 V _{rms} (rated insulation voltage, surge voltage category II, pollution degree 2, safe isolation according to EN 61010, EN 50178) 2.5 kV AC (50 Hz, 1 min., test voltage)	
Transient protection	Yes	
Inflammability class UL 94	V0	
Housing material	Polyamide (PA 6.6)	
Color	Green	
Degree of protection	IP20	
Dimensions (width x height x depth)	12.5 mm x 99 mm x 114.5 mm	
Ambient conditions		
Ambient temperature (operation)	-20 ... +70°C	
Ambient temperature (storage/transport)	-40 ... +85°C	
Permissible humidity (operation)	90% at 25°C (no condensation)	
Conformance		
EMC Directive 2004/108/EC	EN 61326-1 EN 61000-6-2 (When being exposed to interference, there may be minimal deviations.) EN 61000-6-4	
Ex Directive (ATEX)	EN 60079-0 EN 60079-15	

MACX MCR-UI-UI-UP(-SP)(-NC)**Approvals**

ATEX	Ⓜ II 3 G Ex nA IIC T4 Gc	BVS 09 ATEX E 028 X
IECEX approval	Ex nA IIC T4 Gc	IECEX BVS 09.0013X
UL USA/Canada	Ⓜ C.D.-No 83120081	
Functional safety (SIL)	SIL 2 according to EN 61508	DEKRA BVS Pb 02/09
Shipping	GL C / EMC1	

Connection data**Screw connection****Spring-cage connection**

Conductor cross-section (solid)	0.2 ... 2.5 mm ²	0.2 ... 1.5 mm ²
Conductor cross-section (stranded)	0.2 ... 2.5 mm ²	0.2 ... 1.5 mm ²
Stripping length	8 mm	8 mm
Tightening torque	0.5 ... 0.6 Nm	

6 Safety regulations and installation notes

6.1 Installation and operation

Follow the installation instructions.



NOTE: Installation, operation, and maintenance may only be carried out by qualified specialist personnel.

During operation, certain parts of this electric isolating amplifier may carry hazardous voltages. Disregarding this warning may result in damage to equipment and/or serious personal injury.

The potentiometers on the front should only be adjusted using a screwdriver, which is safely isolated from the voltage at the input.

For applications with high operating voltages, ensure sufficient distance or insulation and provide shock protection.

Error-free operation of this device can only be ensured if transport, storage, and assembly are carried out correctly and operation and maintenance are carried out with care.

When installing and operating the device, the applicable safety directives (including national safety directives), accident prevention regulations, as well as general technical regulations, must be observed.



NOTE: The circuits inside the device must not be accessed.

Do not repair the device yourself, replace it with an equivalent device. Repairs may only be carried out by the manufacturer.

Provide a switch/circuit breaker close to the device, which is labeled as the disconnecting device for this device.

Provide overcurrent protection ($I \leq 16$ A) in the installation.

During maintenance work, disconnect the device from all effective power sources.



NOTE: The IP20 degree of protection (IEC 60529/EN 60529) of the device is intended for use in a clean and dry environment. The device must not be subject to mechanical strain and/or thermal loads, which exceed the limits described.

For the safety data, please refer to the operating instructions and certificates (EC-type examination certificate, other approvals, if necessary).

6.2 Safety regulations for installation in potentially explosive areas

Installation in zone 2



WARNING: Explosion hazard

The category 3 device is suitable for installation in potentially explosive area zone 2. It fulfills the requirements of EN 60079-0:2009 and EN 60079-15:2010.



WARNING: Explosion hazard

Install the device in housing (control or distributor box) that meets the requirements of EN 60079-0 and EN 60079-15 and has at least IP54 protection (EN 60529).



WARNING: Explosion hazard

When installing and connecting the supply and signal circuits, observe the requirements of EN 60079-14.

Only devices which are designed for operation in Ex zone 2 and are suitable for the conditions at the installation location may be connected to the circuits in the Ex zone.

In potentially explosive areas, only connect and disconnect cables when the power is disconnected.



WARNING: Explosion hazard

Only use category 3G modules (ATEX 94/9/EC).

Installation in areas with a danger of dust explosions



WARNING: Explosion hazard

The device is **not** designed for installation in areas with a danger of dust explosions.

6.3 Use in safety-related applications (SIL 2)

When using the MACX MCR-UI-UI-UP(-SP)(-NC) in safety-related applications, observe the instructions in Section 9, as the requirements differ for safety-related functions.



NOTE: Install the device in suitable housing with IP54 protection.

7 Installation



NOTE: Electrostatic discharge

The device contains components that can be damaged or destroyed by electrostatic discharge. When handling the device, observe the necessary safety precautions against electrostatic discharge (ESD) according to EN 61340-5-1 and EN 61340-5-2.

Take precautions against electrostatic discharge before opening the front cover.

7.1 Block diagram

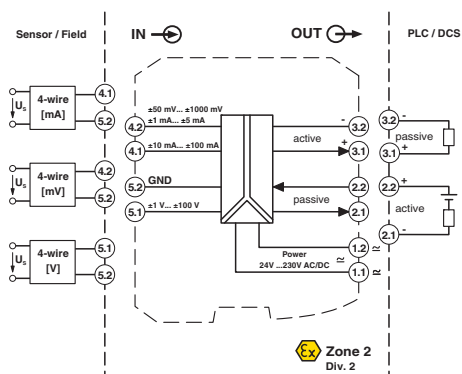

Figure 1 Block diagram with connection terminal blocks

7.2 Structure

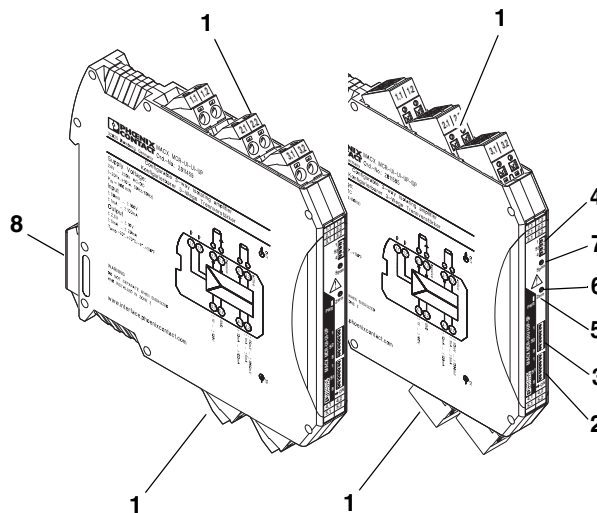

Figure 2 MACX MCR-UI-UI-UP(-SP)(-NC) structure

- 1 Plug-in screw or spring-cage terminal blocks
- 2 DIP switch S1: Input signal ranges
- 3 DIP switch S2: Limit frequency/signal conversion
- 4 DIP switch S3: Output signal ranges
- 5 Green LED: Supply voltage
- 6 ZERO potentiometer
- 7 SPAN potentiometer
- 8 Snap-on foot for fixing on the DIN rail

7.3 Dimensions

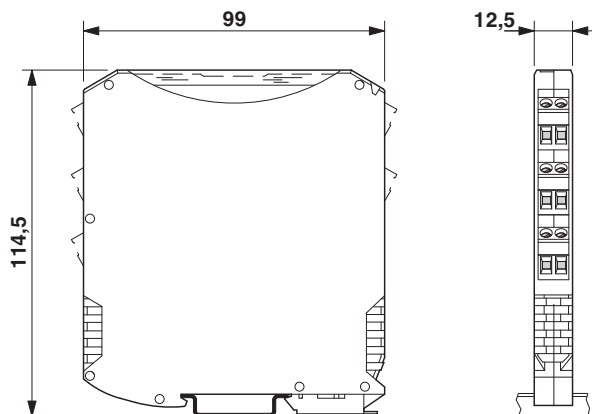

Figure 3 Dimensions (in mm)

7.4 Mounting

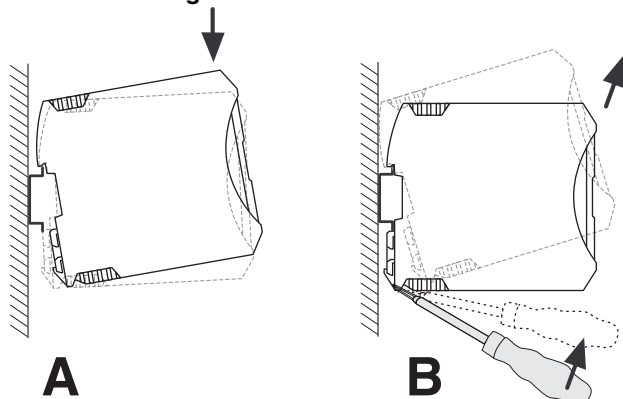

Figure 4 Mounting and removal

- Mount the module on a 35 mm DIN rail according to EN 60715.
- Install the module in suitable housing to meet the requirements for the protection class.
- During startup, check that the MACX MCR-UI-UI-UP(-SP)(-NC) is operating and wired correctly, especially with regard to the wiring and labeling.

7.5 Connecting the cables

- Screw terminal blocks for MACX MCR-UI-UI-UP(-NC); fit litz wires with ferrules. Permissible cable cross-section: 0.2 ... 2.5 mm²
- Spring-cage terminal blocks for MACX MCR-UI-UI-UP-SP(-NC); litz wires can be fitted with ferrules. Permissible cable cross-section: 0.2 ... 1.5 mm²
- Install intrinsically safe and non-intrinsically safe cables separately.
- **Screw connection:**
 - Insert the wire with ferrule into the corresponding connection terminal block.
 - Use a screwdriver to tighten the screw in the opening above the connection terminal block.
- **Spring-cage connection:**
 - Insert a screwdriver into the opening above the connection terminal block.
 - Insert the wire with or without ferrule into the corresponding connection terminal block.

7.6 Application examples

Level measurement

Level measurement and active PLC input board

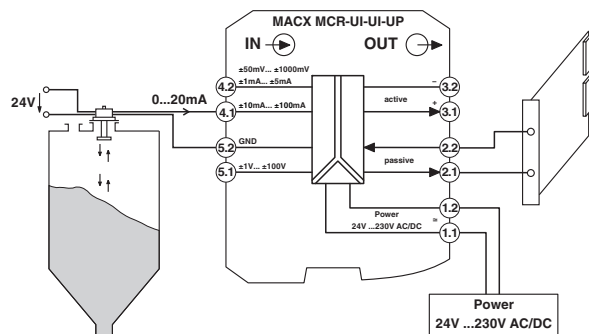

Figure 5 Example, level measurement

Shunt measurement

Shunt measurement and passive PLC input board (Inline terminal with analog input channels within an Inline station from Phoenix Contact)

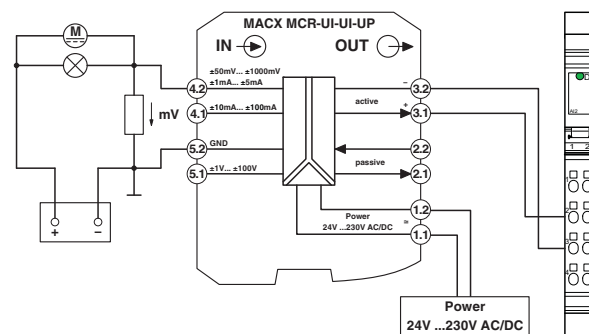

Figure 6 Example, shunt measurement



For additional information about Phoenix Contact automation solutions, please refer to phoenixcontact.net/products.

8 Configuration

8.1 Settings

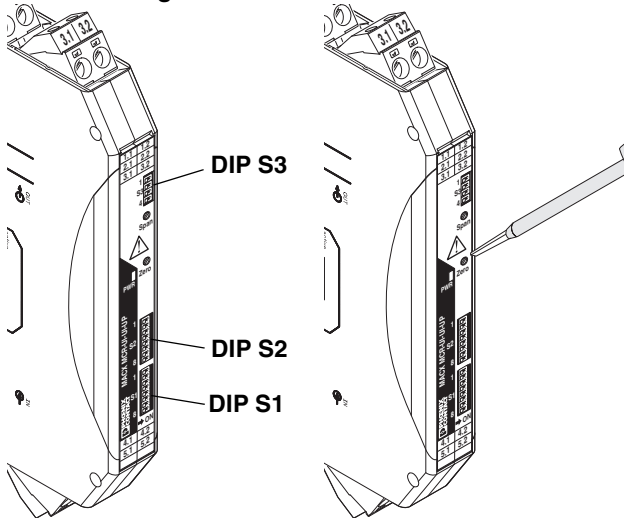

Figure 7 Settings

The desired input and output signal ranges, characteristic curve, and limit frequency can be set via DIP switches using the configuration tables on page 11.

To increase accuracy, carry out a ZERO/SPAN adjustment each time the DIP switch settings are changed. The potentiometers on the front should only be adjusted using a screwdriver, which is safely isolated from the applied voltage.



Due to the wide range of configuration options, a configuration tool (for Excel) can be downloaded at phoenixcontact.net/products.

8.2 Adjustment

Normal characteristic curve (rising input signal, rising output signal)

- Use DIP switch S1 to set the required input range, DIP switch S2 to set the limit frequency/signal conversion, and DIP switch S3 to set the output range.

Example:

Input range $IN_{min} \dots IN_{max} = -10 \text{ V} \dots +10 \text{ V}$

Output range $OUT_{min} \dots OUT_{max} = 0 \text{ V} \dots +10 \text{ V}$

- Specify the input signal using a calibration device and measure the output signal using a multimeter:
 - Specify the initial value of the input range (e.g., $IN_{min} = -10 \text{ V}$).
 - Measure and save the output signal (Measured value 1 = e.g., 0.987 V).
 - Specify the final value of the input range (e.g., $IN_{max} = +10 \text{ V}$).
 - Measure and save the output signal (Measured value 2 = e.g., 9.876 V).
- Calculate the FS (full-scale) adjustment point:
 - Range = Final value of output range - Initial value of output range
 - (E.g., $OUT_{max} - OUT_{min} = 10 \text{ V} - 0 \text{ V} = 10 \text{ V}$)
 - FS adjustment point = Measured value 2 x Range / (Measured value 2 - Measured value 1)
 - E.g., FS adjustment point = $+9.876 \text{ V} \times 10 \text{ V} / (9.876 \text{ V} - 0.987 \text{ V}) = 11.110 \text{ V}$
- Adjustment process:
 - Specify the maximum input signal of the set range (e.g., $IN_{max} = +10 \text{ V}$).
 - Adjust the output signal using the SPAN potentiometer to the calculated FS adjustment point (e.g., 11.110 V).
 - Then adjust the output signal using the ZERO potentiometer to the final value of the output range (e.g., +10 V).
 - E.g., input range $IN_{min} \dots IN_{max} = -10 \text{ V} \dots +10 \text{ V}$, output range $OUT_{min} \dots OUT_{max} = 0 \text{ V} \dots +10 \text{ V}$

8.3 Inverse characteristic curve (rising input signal, falling output signal)

- Use DIP switch S1 to set the input range, DIP switch S2 to set the limit frequency/signal conversion, and DIP switch S3 to set the output range.

Example:

Input range $IN_{\min} \dots IN_{\max} = -10 \text{ V} \dots +10 \text{ V}$

Output range $OUT_{\min} \dots OUT_{\max} = +10 \text{ V} \dots 0 \text{ V}$

- Specify the input signal using a calibration device and measure the output signal using a multimeter:
 - Specify the final value of the input range (e.g., $IN_{\max} = +10 \text{ V}$).
 - Measure and save the output signal (Measured value 1 = e.g., 0.2832 V).
 - Specify the initial value of the input range (e.g., $IN_{\min} = -10 \text{ V}$).
 - Measure and save the output signal (Measured value 2 = e.g., $+10.4238 \text{ V}$).
- Calculate the FS (full-scale) adjustment point:
 - Range = Final value of output range - Initial value of output range
 - (E.g., range = $OUT_{\max} - OUT_{\min} = 10 \text{ V} - 0 \text{ V} = 10 \text{ V}$)
 - FS adjustment point = Measured value 2 x Range / (Measured value 2 - Measured value 1)
 - E.g., FS adjustment point = $+10.4238 \text{ V} \times 10 \text{ V} / (+10.4238 \text{ V} - 0.2832 \text{ V}) = 10.2793 \text{ V}$
- Adjustment process:
 - Specify the minimum input signal of the set range (e.g., $IN_{\max} = -10 \text{ V}$).
 - Adjust the output signal using the SPAN potentiometer to the calculated FS adjustment point (e.g., 10.2793 V).
 - Then adjust the output signal using the ZERO potentiometer to the final value of the output range (e.g., $+10 \text{ V}$).

9 Safety-related applications (SIL 2)

SIL regulations apply to the following modules:

- MACX MCR-UI-UI-UP, Order No. 2811459
- MACX MCR-UI-UI-UP-SP, Order No. 2811585
- MACX MCR-UI-UI-UP-NC, Order No. 2811297
- MACX MCR-UI-UI-SP-NC, Order No. 2811569

Conformance with EN 61508 for safety integrity level SIL 2 is certified by DEKRA EXAM GmbH for the safety-related isolating amplifiers of the MACX MCR-UI-UI-UP(-SP)(-NC) series.

Test report No.: DEKRA BVS Pb 02/09

9.1 Safety function and safety requirements

Safety requirements

The isolating amplifier can be used as both an input and an output isolating amplifier. Depending on the application, it is installed either in the signal branch between sensor and PLC (input isolating amplifier) or between PLC and actuator. This results in differing considerations for the safe state of the device. In all cases, the isolating amplifier is set up using simple analog components, and monitoring measures are not provided. Safety is ensured by the fact that the output signal switches to the safe state in the event of an error.

Safety functions

The safety function is based on forwarding the 4 ... 20 mA standard signal with a tolerance of 5%. In the event of an error, the system enters the safe state (failsafe state).

Safe state and error definition for the input isolating amplifier

Output values of less than 3.6 mA or greater than 21.6 mA are specified as the failsafe state of the system.

Safe failures are therefore errors where the isolating amplifier provides an output signal that is outside the normal range.

Dangerous failures are errors where the isolating amplifier does not follow a change in the input signal or provides an output signal that deviates from the input signal by more than 5%.

Safe state and error definition for the output isolating amplifier

Output values ≤ 3.6 mA are specified as the failsafe state of the system.

Safe failures are therefore errors where the isolating amplifier provides an output signal that is below the normal range.

Dangerous failures are errors where the isolating amplifier does not follow a change in the input signal or provides an output signal that deviates from the input signal by more than 5% or if the output signal is ≥ 21.6 mA.

Operating mode of the safety function

Although there is no monitoring of the output signal and no internal diagnostic circuits, the safety function itself should only respond extremely rarely, and therefore a low demand rate for the safety function is assumed. However, for continuous operation with continuous signal transmission, a higher demand rate should also be assumed.

Startup and restart

When the isolating amplifier is started (power ON), the voltages required for operation are connected to supply the circuit. A signal proportional to the input signal is then generated at the output.

Summary

The evaluation unit following the input isolating amplifier (e.g., safety-related PLC) must recognize and evaluate output values ≤ 3.6 mA or ≥ 21.6 mA (live zero) outside the nominal range and control the actuator accordingly as the final link in the safety chain.

For the SIL capability of the device, only input and output signal ranges with a live zero signal can be used. During circuit analysis, only very slight differences were identified for the various ranges (4 ... 20 mA, 1 ... 5 mA, 2 ... 10 V, 1 ... 5 V, active or passive output), and therefore the average values from the analysis are used in the following text.

For all other measuring ranges, sufficient isolation cannot be ensured between the error signal (measuring range overrange or underrange) and the measurement signal, which means that SIL capability cannot be ensured for these ranges.

9.2 Safety integrity requirements

Error rates for input isolator:

- Type A device (according to EN 61508-2)
- SIL capability: Up to SIL 2
- 1oo1 architecture
- HFT = 0
- DCD = 0

λ_{sd}	λ_{su}	λ_{dd}	λ_{du}	SFF
0	3.7×10^{-7}	0	6.0×10^{-8}	85.9%

The total failure rate is: 4.94×10^{-7}

MTBF (Mean Time Between Failures) is: 231 years

The probability of a dangerous failure per hour for "continuous" mode and the average probability of failure of the specified function for "low demand" mode are determined from the error rate:

PFD_{avg} values

T _[PROOF] =	1 year	2 years	3 years	4 years	5 years
PFD _{avg} =	2.7×10^{-4}	5.3×10^{-4}	7.9×10^{-4}	10.6×10^{-4}	13.2×10^{-4}

PFH* = 6.0×10^{-8} /h

The calculation is performed assuming a checking interval of one year (8760 hours) and a repair time of 8 hours.

On the basis of the value determined for the average probability of failure PFD_{avg}, the checking interval can be increased to three years if the percentage of the device for the entire loop is assumed at 10%.

The values are valid under these conditions:

- The failure rates of the components used remain constant throughout the period of use.
- The propagation of errors by the device in the system is not taken into consideration.
- The repair time (replacement) is eight hours.
- The failure rates of the external power supply are not taken into consideration.
- The average temperature at which the device is to be used is +40°C.
- In this case, normal industrial conditions are assumed.
- The specified error rates are based on an average ambient temperature of +40°C. For an average ambient temperature of +60°C, the error rates must be multiplied by factor 2.5. Factor 2.5 is based on guide values.

Error rates for output isolator:

- Type A device (according to EN 61508-2)
- SIL capability: Up to SIL 2
- 1oo1 architecture
- HFT = 0
- DCD = 0

λ_{sd}	λ_{su}	λ_{dd}	λ_{du}	SFF
0	3.5×10^{-7}	0	7.3×10^{-8}	82.7%

The total failure rate is: 4.90×10^{-7}

MTBF (Mean Time Between Failures) is: 233 years

The probability of a dangerous failure per hour for "continuous" mode and the average probability of failure of the specified function for "low demand" mode are determined from the error rate:

PFD_{avg} values

T _[PROOF] =	1 year	2 years	3 years	4 years	5 years
PFD _{avg} =	3.2×10^{-4}	6.4×10^{-4}	9.6×10^{-4}	12.9×10^{-4}	16.1×10^{-4}

PFH* = 7.3×10^{-8} /h

The calculation is performed assuming a checking interval of one year and a repair time of 8 hours.

On the basis of the value determined for the average probability of failure PFD_{avg}, the checking interval can be increased to three years if the percentage of the device for the entire loop is assumed at 10%.

The values are valid under these conditions:

- The failure rates of the components used remain constant throughout the period of use.
- The propagation of errors by the device in the system is not taken into consideration.
- The repair time (replacement) is eight hours.
- The failure rates of the external power supply are not taken into consideration.
- The average temperature at which the device is to be used is +40°C.
- In this case, normal industrial conditions are assumed.
- The specified error rates are based on an average ambient temperature of +40°C. For an average ambient temperature of +60°C, the error rates must be multiplied by factor 2.5. Factor 2.5 is based on guide values.

9.3 Configuring a SIL device

SIL = Live zero for input and output

9.4 Installation and startup

During installation, always observe the instructions in package slip PACKB.MACX MCR-UI-UI-UP(-SP)(-NC), (MNR 9045729).

The package slip is supplied with the device. It can also be downloaded at phoenixcontact.net/products.

Lockable housing with IP54 protection is recommended for the installation of the isolating amplifier.

- Check that the configuration of the isolating amplifier is correct for the intended application.
- Connect the isolating amplifier according to the installation instructions.
- Make sure that the connected devices correspond to the configuration
- Check that the isolating amplifier operates correctly with the connected devices.
- Start up the loop and check that it operates correctly.

9.5 Notes on operation

During normal operation, the green (PWR) LED is on.

9.6 Recurring checks (SIL 2)

The function of the entire safety loop must be checked regularly according to EN 61508 and EN 61511. The intervals for checking are specified by the intervals of each individual device within the safety loop.

It is the operator's responsibility to select the type of checks and the checking intervals in the specified time period.

MACX MCR-UI-UI-UP(-SP)(-NC) isolating amplifiers must be checked at least every 3 years (maximum proof test interval where the percentage for the loop is assumed at 10%).

Checking must be carried out in such a way that the correct operation of the safety equipment in conjunction with all components can be verified.

Possible procedure for recurring checks for discovering dangerous and undetected device failures

A calibrated sensor simulator (current or voltage source) and a calibrated digital multimeter are necessary for checking the isolating amplifier.

- Connect the sensor simulator to the input of the isolating amplifier using the appropriate connection method.
- Connect the digital multimeter in current measuring mode (20 mA range) or voltage measuring mode (10 V range) to the output.

The measuring range limits and intermediate values are specified with the sensor simulator.

The corresponding output values of the isolating amplifier must be checked on the digital multimeter.

If the output values deviate from the expected values, this can be corrected by the ZERO/SPAN function (see "Adjustment" on page 9).

If the function test result is negative, the isolating amplifier must be taken out of operation and the process put into a safe state by other means.

9.7 Repair

The devices have a long service life, are protected against malfunction, and do not require maintenance. However, if a device should fail, send it back to Phoenix Contact immediately. The type of malfunction and possible cause must also be stated.

Please use the original packaging or other suitable safe packaging when sending devices back for repair or recalibration.

Phoenix Contact GmbH & Co. KG
Abteilung Service und Reparatur
Flachmarktstr. 8
32825 Blomberg
GERMANY

9.8 Standards (SIL 2)

The isolating amplifiers are developed and tested according to the following standards:

EN 61508: Functional safety of electrical/electronic/programmable electronic safety-related systems
2001

EN 61326-1: Electrical equipment for measurement, control and laboratory use – EMC requirements
2006

IEC 61326-3-2: Electrical equipment for measurement, control and laboratory use – EMC requirements – Part 3-2: Immunity requirements for safety-related systems and for equipment intended to perform safety-related functions (functional safety) – Industrial applications with specified electromagnetic environment
2006

9.9 Abbreviations

Abbreviation		Meaning
DC _D	Diagnostic Coverage of Dangerous Failures	Diagnostic coverage: $DC_D = \lambda_{dd}/(\lambda_{du} + \lambda_{dd})$
HFT	Hardware Fault Tolerance	Hardware fault tolerance: Ability of a function unit to continue with the execution of a demanded function despite existing errors or deviation
λ_d	Rate of Dangerous Failures	Proportion of dangerous failures per hour
λ_{dd}	Rate of Dangerous Detected Failures	Proportion of detected dangerous failures per hour
λ_{du}	Rate of Dangerous Undetected Failures	Proportion of undetected dangerous failures per hour
λ_s	Rate of Safe Failures	Proportion of safe failures per hour
MTBF	Mean Time Between Failures	Mean time between consecutive failures
PFD _{avg}	Average Probability of Failure on Demand	Average probability of failure on demand of a safety function
PFH	Probability of a Dangerous Failure per Hour	Probability of failure per hour for the safety function
SFF	Safe Failure Fraction	Proportion of safe failures: Proportion of failures without the potential to set the safety-related system to a dangerous or impermissible function state
SIL	Safety Integrity Level	International standard IEC 61508 defines four discrete safety integrity levels (SIL 1 to 4). Each level corresponds to a probability range for the failure of a safety function. The higher the safety integrity level of safety-related systems, the lower the probability that the demanded safety functions will not be performed.



SCATTERGOOD & JOHNSON LTD

ELECTRICAL ENGINEERING & FLUID CONTROL DISTRIBUTORS

Est.1899

At Scattergood & Johnson Ltd, we pride ourselves on being a technical distributor to specialist industries.

Working with a range of quality product suppliers across a number of specialist markets, we are not your average 'box shifter' - we are your technical and supply chain partner.

We fully support every product we sell - for free! Our internal team and external sales engineers can answer any product or application question, no matter the complexity.

Backing up this technical ability is a range of 50,000+ products available from stock for nationwide next day delivery (same day if required!), or you can collect what you need from any of our trade counters around the UK.

Select your specialist interest below to learn more about how we can help.

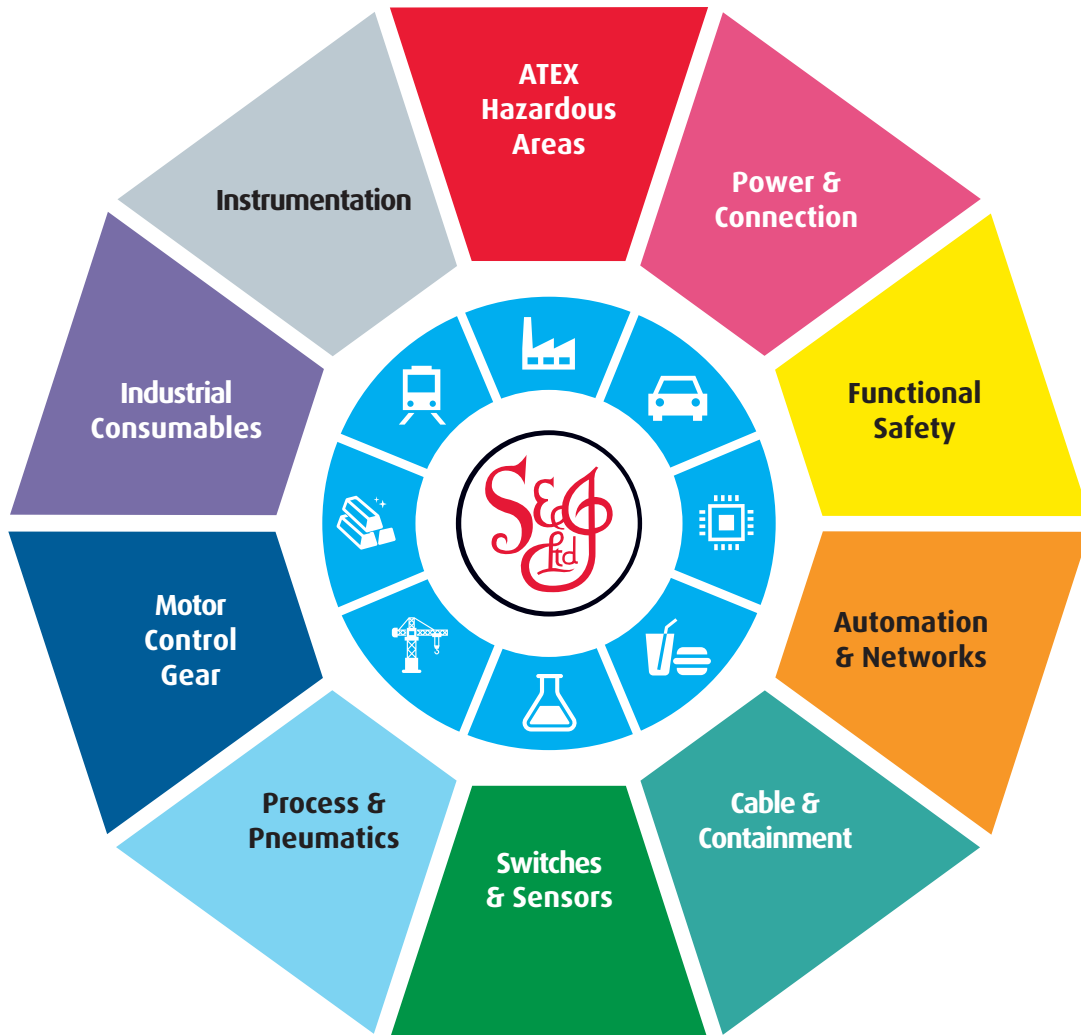

Online, In Branch and On the Road - Scattergood & Johnson Ltd, there when you need us.

www.scatts.co.uk