

MINI MCR-SL-UI-F

Configurable analog frequency transducer



Data sheet
102477_en_11

© PHOENIX CONTACT 2012-01-06

1 Description

The 6.2 mm narrow MINI MCR-SL-UI-F... configurable analog frequency transducers is used for converting analog standard signals in frequency signals or pulse width modulated (PWM) signals (in the range of 5 ... 95%).

Standard signals 0...20 mA, 4...20 mA, 0...10 mA, 2...10 mA, 0...10 V, 2...10 V, 0...5 V or 1...5 V can be selected on the input side.

The DIP switches are accessible on the side of the housing and allow the following parameters to be configured:

- Input signal
- Output signal
- Output behavior during measured value over- or under-range as well as
- filter type (for smoothing interference of the input signal).

Power (19.2 V DC to 30 V DC) can be supplied through connection terminals on the modules or in conjunction with the DIN rail connector.

Features

- Configurable analog frequency transducer
- Configurable via DIP switch
- Approval for Ex-zone 2 (nA)
- Screw or spring-cage connection can be provided



WARNING: Correct usage in potentially explosive areas

The module is a category 3 item of electrical equipment. It is absolutely vital to follow the instructions provided here during installation and observe the information in the "Safety regulations and installation notes".



Make sure you always use the latest documentation.

It can be downloaded from the product at www.phoenixcontact.net/catalog.



This data sheet is valid for all products listed on the following page:

2	Table of contents	
1	Description	1
2	Table of contents	2
3	Ordering data	3
4	Technical data	3
5	Safety regulations and installation notes.....	5
	5.1 Installation notes	5
	5.2 Installation in the Ex area (zone 2).....	5
6	Installation	6
	6.1 Connection notes	6
	6.2 Structure	7
	6.3 Block diagram.....	7
	6.4 Power supply.....	7
	6.5 Assembly.....	8
	6.6 Connecting the wires	8
7	Configuration	9
	7.1 Moving Average Filter:	9
	7.2 Oversampling filter	9
8	Configuration table	10
9	Output signals.....	11
10	Connection/application example	11
	10.1 Connection of a high-resistance passive digital input	11

3 Ordering data

Description	Type	Order No.	Pcs. / Pkt.
Analog frequency transducers for converting analog standard signals into frequency signals or PWM signals, configurable via DIP switch, with screw connection	MINI MCR-SL-UI-F	2864082	1
MCR analog frequency transducers for converting analog standard signals into frequency signals or PWM signals, with spring-cage connection	MINI MCR-SL-UI-F-SP	2810243	1
Accessories	Type	Order No.	Pcs. / Pkt.
DIN rail connector (TBUS), 5-pos., for bridging the supply voltage, can be snapped onto NS 35/... DIN rails according to EN 60715	ME 6,2 TBUS-2 1,5/5-ST-3,81 GN	2869728	10
MCR power terminal block for supplying several MINI Analog modules via the DIN rail connectors, with screw connection, current consumption up to max. 2 A	MINI MCR-SL-PTB	2864134	1
MCR power terminal block for supplying several MINI-ANALOG modules via the DIN rail connectors, with spring-cage connection, current consumption up to max. 2 A	MINI MCR-SL-PTB-SP	2864147	1
DIN rail power supply unit, primary-switched mode, slim design, output: 24 V DC / 1.5 A	MINI-SYS-PS-100-240AC/24DC/1.5	2866983	1
DIN rail power supply unit, primary-switched mode, slim design, output: 24 V DC / 1.5 A, ATEX approval	MINI-PS-100-240AC/24DC/1.5/EX	2866653	1
Eight MINI analog signal converters with screw connection method can be connected to a control system using a system adapter and system cabling with a minimum of wiring and very low error risk.	MINI MCR-SL-V8-FLK 16-A	2811268	1
Fold up transparent cover for MINI MCR modules with additional labeling option using insert strips and flat Zack marker strip 6.2 mm	MINI MCR DKL	2308111	10
Label for extended marking of MINI MCR modules in connection with the MINI MCR-DKL	MINI MCR-DKL-LABEL	2810272	10

4 Technical data

Input	
Configurable/programmable	Yes
Voltage input signal	0 V ... 5 V 1 V ... 5 V 0 V ... 10 V 2 V ... 10 V
Max. voltage input signal	30 V DC
Current input signal	0 mA ... 20 mA 4 mA ... 20 mA 0 mA ... 10 mA 2 mA ... 10 mA
Max. current input signal	100 mA
Input resistance of voltage input	Approx. 110 k Ω
Input resistance current input	Approx. 50 Ω
Behavior in the event of an error	Alarm in the form of a red LED

Output		
Frequency output	0 Hz ... 10 kHz 0 Hz ... 5 kHz 0 Hz ... 2.5 kHz 0 Hz ... 1 kHz 0 Hz ... 500 Hz 0 Hz ... 250 Hz 0 Hz ... 100 Hz 0 Hz ... 50 Hz	
Load min.	$(4 \text{ mA} \leq (U_L / R_L) \leq 20 \text{ mA})$	
Output signal PWM	7.8 kHz (10 bit) 3.9 kHz (10 bit) 1.9 kHz (12 bit) 977 Hz (12 bit) 488 Hz (14 bit) 244 Hz (14 bit) 122 Hz (16 bit) 61 Hz (16 bit)	
Load min.	$(12 \text{ mA} \leq (U_L / R_L) \leq 20 \text{ mA})$	
Load current maximum	20 mA	
Maximum switching voltage	30 V	
Overrange/underrange	Can be set (via DIP switch)	
Protective circuit	Short-circuit protection, polarity reversal protection	
Supply		
Nominal supply voltage	24 V DC	
Supply voltage range	19.2 V DC ... 30 V DC (to bridge the supply voltage, the DIN rail connector (ME 6,2 TBUS-2 1,5/5-ST-3,81 GN, Order No. 2869728) can be used. It can be snapped onto a 35 mm DIN rail according to EN 60715)	
Max. current consumption	< 10 mA (at 24 V DC)	
Power consumption	< 200 mW	
General data		
Maximum transmission error	$\leq 0.1 \% (> 7 \text{ kHz} \leq 0,2 \%)$	
Maximum temperature coefficient	< 0.02 %/K	
Step response (0–99%)	< 15 ms (+ (1/f)) < 1 s (+ (1/f) largest filter)	
Electrical isolation	Basic insulation according to EN 61010	
Surge voltage category	II	
Mounting position	Any	
Degree of protection	IP20	
Pollution degree	2	
Rated insulation voltage	50 V AC/DC	
Test voltage, input/output/supply	1.5 kV (50 Hz, 1 min.)	
Dimensions W / H / D	6.2 mm / 93.1 mm / 102.5 mm	
Type of housing	PBT green	
Connection data		
	Screw connection	Spring-cage conn.
Conductor cross section, solid	0.2 mm ² ... 2.5 mm ²	0.2 mm ² ... 2.5 mm ²
Conductor cross section, stranded	0.2 mm ² ... 2.5 mm ²	0.2 mm ² ... 2.5 mm ²
Stripping length	12 mm	8 mm
Ambient conditions		
Ambient temperature (operation)	-20 °C ... 65 °C	
Ambient temperature (storage/transport)	-40 °C ... 85 °C	

Conformance with EMC Directive 2004/108/EC

Noise immunity according to EN 61000-6-2

Noise emission according to EN 61000-6-4

Conformance / approvals

Conformance

CE-compliant

ATEX

 II 3 G Ex nA IIC T4 Gc X

UL, USA / Canada

UL 508 Recognized

UL, USA / Canada

Class I, Div. 2, Groups A, B, C, D T5 applied for

Shipbuilding

GL EMC 2 D

5 Safety regulations and installation notes

5.1 Installation notes

- The category 3 device is suitable for installation in the zone 2 potentially explosive area. It fulfills the requirements of EN 60079-0:2009 and EN 60079-15:2010.
- Installation, operation, and maintenance may only be carried out by qualified electricians. Follow the installation instructions described. When installing and operating the device, the applicable regulations and safety directives (including national safety directives), as well as general technical regulations, must be observed. The technical data is provided in this package slip and on the certificates (conformity assessment, additional approvals where applicable).
- It is not permissible to open or modify the device. Do not repair the device yourself but replace it with an equivalent device. Repairs may only be carried out by the manufacturer. The manufacturer is not liable for damage resulting from violation.
- The IP20 degree of protection (IEC 60529/EN 60529) of the device is intended for use in a clean and dry environment. Do not subject the device to any load that exceeds the described limits.
- The device is not designed for use in atmospheres with a danger of dust explosions.

5.2 Installation in the Ex area (zone 2)

- Observe the specified conditions for use in potentially explosive areas.
- The device must be installed in a housing (control or distributor box) which meets the requirements of EN 60079-15 and provides at least IP54 (EN 60529) degree of protection.
- During installation and when connecting the supply and signal circuits, observe the requirements of EN 60079-14. Devices may only be connected to circuits in zone 2 if they are suitable for operation in Ex zone 2 and for the prevailing conditions at the place of use.
- In potentially explosive areas, terminals may only be snapped onto or off the DIN rail connector and wires may only be connected or disconnected when the power is switched off.
- The device must be stopped and immediately removed from the Ex area if it is damaged, has been subjected to an impermissible load, has been stored incorrectly, or if it malfunctions.
- You can download the latest documents for these devices from www.phoenixcontact.net/catalog.

6 Installation

6.1 Connection notes



NOTE: Electrostatic discharge!

The device contains components that can be damaged or destroyed by electrostatic discharge. When handling the device, observe the necessary safety precautions against electrostatic discharge (ESD) according to EN 61340-5-1 and EN 61340-5-2.



In order to ensure the correct function of the module, the following output circuit must be observed.

Make sure that the output is floating during configuration of the output circuit.

Please connect the corresponding voltage supply to the output circuit.

At the same time, a minimum current must flow at the output of the module so that the output transistor can switch through.

The minimum current at the frequency output is 4 mA.

The minimum current at the PWM output is 12 mA.

In order to ensure the minimum current flow, please observe the following formula and the example circuit diagram:

The minimum current flow is achieved by adapting the applied UL voltage and the RL load resistance.

The maximum permitted values at the the transistor output are 30 V DC, 20 mA.

Formula for calculating:

Frequency output: $4 \text{ mA} \leq (UL/RL) \leq 20 \text{ mA}$

PWM output: $12 \text{ mA} \leq (UL/RL) \leq 20 \text{ mA}$

Example:

They work at the output with a digital input module that has an input resistance of 5 K Ω .

24 V DC is available at the output as UL switching voltage.

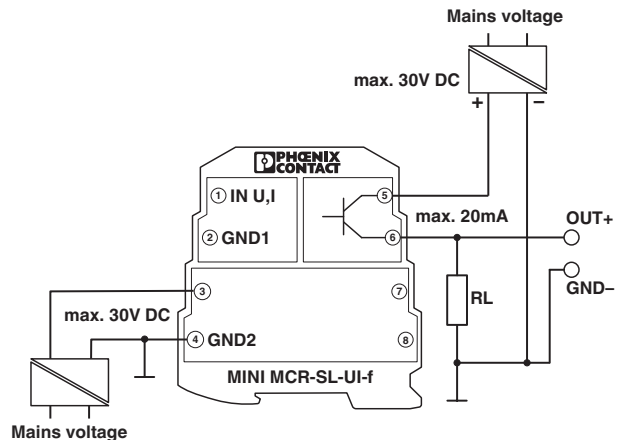

Figure 1 MINI MCR-SL-UI-F...

Task:

It must use the frequency output of the module. The required current flow is therefore calculated as follows:

$$4 \text{ mA} \leq (24 \text{ V} / 5 \text{ K}\Omega) \leq 20 \text{ mA} = 4 \text{ mA} \leq 4.8 \text{ mA} \leq 20 \text{ mA}$$

This then ensures a sufficient current flow.

6.2 Structure

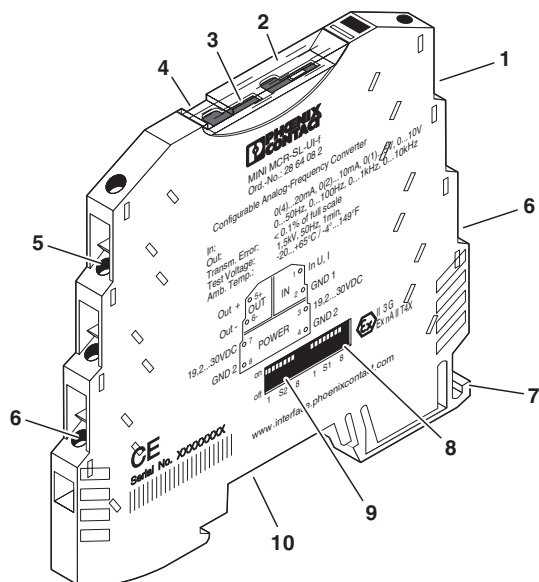

Figure 2 Structure

1. Input: Standard signals
2. Cover
3. Diagnostics LED
4. Groove for ZBF 6 zack marker strip
5. Output: Frequency signals
6. Supply voltage
7. Universal snap-on foot for EN DIN rails
8. DIP switch S1
9. DIP switch S2
10. Connection option for DIN rail connector

6.3 Block diagram

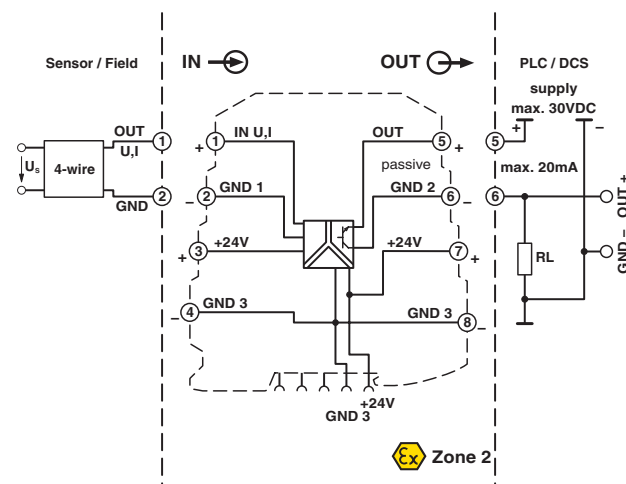

Figure 3 Block diagram

6.4 Power supply



NOTE: Never connect the supply voltage directly to the DIN rail connector. It is not permitted to draw power from the DIN rail connector or from individual modules.

Supply via the MINI Analog Module

Where the total current consumption of the aligned MINI Analog modules does not exceed 400 mA, the power can be supplied directly at the connection terminal blocks of one MINI Analog module.

A 400 mA fuse should be connected upstream.

Supply via a Power Terminal Block

The MINI MCR-SL-PTB power terminal block (Order No. 2864134) or the MINI MCR-SL-PTB-SP power terminal block (Order No. 2864147), which are the same shape, are used to feed the supply voltage to the DIN rail connector.

A 2 A fuse should be connected upstream.

Supply via a system power supply unit

The system power supply unit with 1.5 A output current connects the DIN rail connector to the supply voltage and can therefore be used to supply several modules from the mains.

- MINI-SYS-PS-100-240AC/24DC/1.5 (Order No. 2866983)
- Potentially explosive areas:
MINI-PS-100-240AC/24DC/1.5/EX (Order No. 2866653)

6.5 Assembly

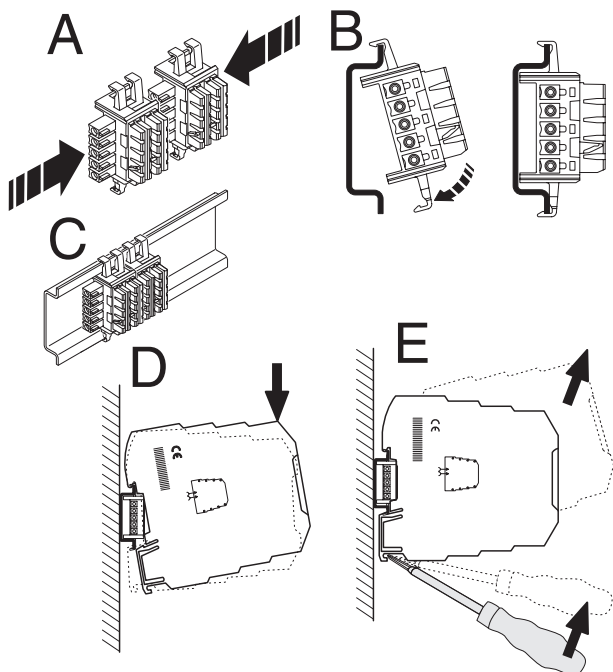

Figure 4 Mounting and removing

- Mount the module on a 35 mm DIN rail according to EN 60715.
- When using the DIN rail connector, first place it into the DIN rail (see A – C). It is used to bridge the power supply. It is also absolutely vital that you snap the module and the DIN rail connector into position in the correct direction: the snap-on foot should be at the bottom and the connector on the left.

6.6 Connecting the wires

The MINI MCR-SL-UI-F... is available in two connection variants:

- Screw terminals (MINI MCR-SL-UI-F)
- Spring-cage terminals (MINI MCR-SL-UI-F-SP)

Screw connection:

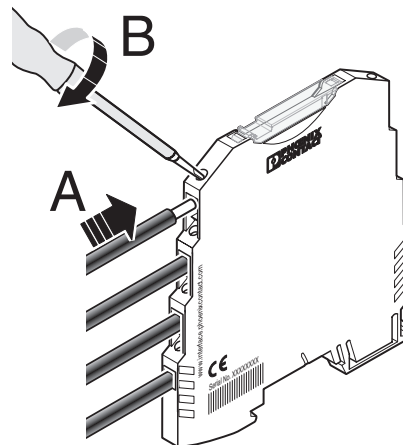

Figure 5 Screw connection

- Insert the wire into the corresponding connection terminal block.
- Use a screwdriver to tighten the screw in the opening above the connection terminal block.

Spring-cage connection:

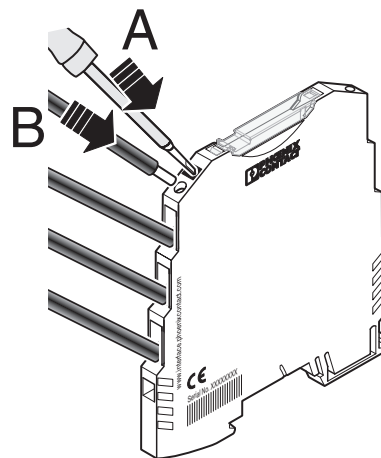

Figure 6 Spring-cage connection

- Insert a screwdriver into the opening above the connection terminal block.
- Insert the wire into the corresponding connection terminal block.

7 Configuration

The modules have the standard configuration:

- 0 ... 10 V input
- Measured value overrange: Freeze at 100% measuring range end value
- Underrange: Freeze at 100% measuring range start value
- Output: Frequency output 0...10 kHz
- Moving Average Filter: 1 value
- Oversampling: 1 value

(All DIP switches are set to the "OFF" position)

You can change the input valued for Moving Average Filter and Oversampling with the DIP switch S1 and the output values as well as the measuring range overrange/underrange with the DIP switch S2.

7.1 Moving Average Filter:

The connectable moving average filter combines the values (1, 2, 4, 6) to a new measured value according to the bucket chain procedure. In the bucket chain procedure, the average of a fixed number of measured values is taken, whereby the oldest value is always dropped and the most recent added.

7.2 Oversampling filter

In order to smooth the measured values, an average can be formed from several measured values (1, 10, 50, 100) (oversampling).

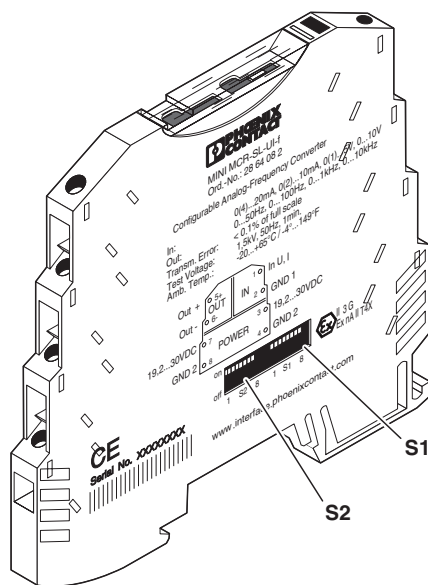

Figure 7 Location of the DIP switches

8 Configuration table

DIP S1				Analog IN		Moving average filter		Oversampling	
1	2	3	4			5	6	7	8
				0 ... 10 V				1 value	
•				1 ... 5 V		•		2 values	
	•			0 ... 5 V			•	4 values	
		•		2 ... 10 V		•	•	6 values	
•			•	0 ... 20 mA				1 value	
•	•		•	4 ... 20 mA				10 values	
•		•	•	0 ... 10 mA				50 values	
•	•	•	•	2 ... 10 mA		•	•	100 values	

DIP S2				OUT f/PWM		Overrange		Underrange	
1	2	3	4			5	6	7	8
				0 ... 10 kHz				Freeze at 100% measuring range final value	
•				0 ... 5 kHz				Freeze at 100% measuring range start value	
	•			0 ... 2.5 kHz		•		105% measuring range final value	
•	•			0 ... 1 kHz				105% measuring range final value	
		•		0 ... 500 Hz		•	•	110% measuring range final value	
•	•			0 ... 250 Hz				110% measuring range final value	
	•	•		0 ... 100 Hz		•	•	Error detection OFF	
•	•	•		0 ... 50 Hz				Error detection OFF	
			•	10 bits, 7.8 kHz					
•			•	10 bits, 3.9 kHz					
	•		•	12 bits, 1.9 kHz					
•	•		•	12 bits, 977 Hz					
		•	•	14 bits, 488 Hz					
•	•	•		14 bits, 244 Hz					
	•	•	•	16 bits, 122 Hz					
•	•	•	•	16 bits, 61 Hz					

- ≙ ON
- ≙ OFF

9 Output signals

The input signals can be converted to frequency signals or pulse width modulated (PWM) signals (5-95%).

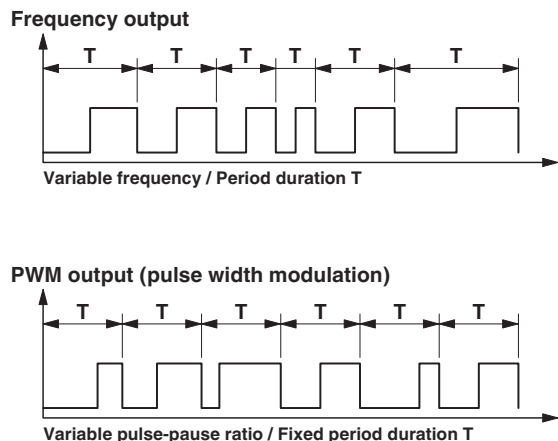

Figure 8 Output signals

10 Connection/application example

10.1 Connection of a high-resistance passive digital input

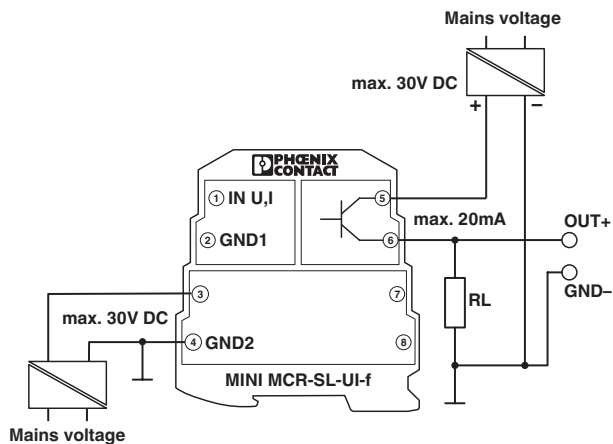

Figure 9 MINI MCR-SL-UI-F...



SCATTERGOOD & JOHNSON LTD

ELECTRICAL ENGINEERING & FLUID CONTROL DISTRIBUTORS

Est.1899

At Scattergood & Johnson Ltd, we pride ourselves on being a technical distributor to specialist industries.

Working with a range of quality product suppliers across a number of specialist markets, we are not your average 'box shifter' - we are your technical and supply chain partner.

We fully support every product we sell - for free! Our internal team and external sales engineers can answer any product or application question, no matter the complexity.

Backing up this technical ability is a range of 50,000+ products available from stock for nationwide next day delivery (same day if required!), or you can collect what you need from any of our trade counters around the UK.

Select your specialist interest below to learn more about how we can help.



Online, In Branch and On the Road - Scattergood & Johnson Ltd, there when you need us.

www.scatts.co.uk