

# MINI MCR-SL-PT100-UI

## Active resistance thermometer measuring transducer

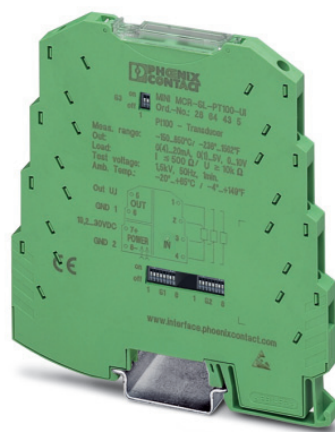

Data sheet  
101949\_en\_06

© PHOENIX CONTACT 2012-04-24

## 1 Description

The 6.2 mm wide MINI MCR-SL-PT100-UI... is a configurable, 3-way isolated temperature measuring transducer. It is suitable for connecting Pt 100-resistance thermometers according to IEC 60751 in 2, 3 and 4-conductor connection method.

The electrically isolated analog standard signals 0...20 mA, 4...20 mA, 0...10 V, 0...5 V, 1...5 V, 10...0 V, 20...0 mA or 20...4 mA are available on the output side.

The DIP switches are accessible on the side of the housing and allow the following parameters to be configured:

- Connection method
- Temperature range to be measured
- Output signals as well as
- Type of fault evaluation

the voltage (19.2 V DC to 30 V DC) can be supplied either via the connection terminal blocks of the module or in conjunction with the DIN rail connector.

### Features

- Configurable 3-way temperature transducer
- 2-, 3-, 4-conductor connection method for Pt 100 resistance thermometer
- Measuring range 0 °C to 850 °C
- Output signal range 0...20 mA, 4...20 mA, 0...10 V, 0...5 V, 1...5 V, 10...0 V, 20...0 mA or 20...4 mA
- Approval for Ex-zone 2 (nA)
- Screw or spring-cage connection can be provided
- Can be supplied configured or unconfigured



### **WARNING: Correct usage in potentially explosive areas**

The module is a category 3 item of electrical equipment. It is absolutely vital to follow the instructions provided here during installation and observe the information in the "Safety regulations and installation notes".



Make sure you always use the latest documentation.

It can be downloaded from the product at [www.phoenixcontact.net/catalog](http://www.phoenixcontact.net/catalog).



This data sheet is valid for all products listed on the following page:

---

<b>2</b>	<b>Table of contents</b>	
1	Description .....	1
2	Table of contents .....	2
3	Ordering data .....	3
	3.1 Order key .....	4
4	Technical data .....	5
5	Safety regulations and installation notes.....	7
	5.1 Installation notes .....	7
	5.2 Installation in the Ex area (zone 2).....	7
6	Installation .....	8
	6.1 Connection notes .....	8
	6.2 Structure .....	8
	6.3 Block diagram.....	8
	6.4 Power supply.....	8
	6.5 Assembly.....	9
	6.6 Connecting the wires .....	9
7	Configuration .....	10
	7.1 Configuration table.....	11
8	Diagnostics LED .....	12
9	Connection/application example .....	12

### 3 Ordering data

Description	Type	Order No.	Pcs. / Pkt.
MCR temperature transducer for Pt 100 temperature sensors, configured via DIP switch, with screw connection, pre-configured (pay attention to the order key)	MINI MCR-SL-PT100-UI	2864435	1
MCR temperature transducer for Pt 100 temperature sensors, configured via DIP switch, with spring-cage connection, pre-configured	MINI MCR-SL-PT100-UI-SP	2864736	1
MCR temperature transducer for Pt 100 temperature sensors, configured via DIP switch, with screw connection, not pre-configured	MINI MCR-SL-PT100-UI-NC	2864273	1
MCR temperature transducer for Pt 100 temperature sensors, configured via DIP switch, with spring-cage connection, not pre-configured	MINI MCR-SL-PT100-UI-SP-NC	2864286	1
Accessories	Type	Order No.	Pcs. / Pkt.
DIN rail connector (TBUS), 5-pos., for bridging the supply voltage, can be snapped onto NS 35/... DIN rails according to EN 60715	ME 6,2 TBUS-2 1,5/5-ST-3,81 GN	2869728	10
MCR power terminal block for supplying several MINI Analog modules via the DIN rail connectors, with screw connection, current consumption up to max. 2 A	MINI MCR-SL-PTB	2864134	1
MCR power terminal block for supplying several MINI-ANALOG modules via the DIN rail connectors, with spring-cage connection, current consumption up to max. 2 A	MINI MCR-SL-PTB-SP	2864147	1
DIN rail power supply unit, primary-switched mode, slim design, output: 24 V DC / 1.5 A	MINI-SYS-PS-100-240AC/24DC/1.5	2866983	1
DIN rail power supply unit, primary-switched mode, slim design, output: 24 V DC / 1.5 A, ATEX approval	MINI-PS-100-240AC/24DC/1.5/EX	2866653	1
Eight MINI analog signal converters with screw connection method can be connected to a control system using a system adapter and system cabling with a minimum of wiring and very low error risk.	MINI MCR-SL-V8-FLK 16-A	2811268	1
Fold up transparent cover for MINI MCR modules with additional labeling option using insert strips and flat Zack marker strip 6.2 mm	MINI MCR DKL	2308111	10
Label for extended marking of MINI MCR modules in connection with the MINI MCR-DKL	MINI MCR-DKL-LABEL	2810272	10
MINI analog multiplexer, generates one analog output from 8 analog input signals, for MINI analog module with screw connection.	MINI MCR-SL-MUX-V8-FLK 16	2811815	1

### 3.1 Order key

(standard configuration entered as example)

Order No.	Conne- tion method	Measuring range [°C]		Output	Failure- information 1)	Factory calibration certificate
		Start	End			
<b>2864435</b>	<b>3</b>	<b>0</b>	<b>100</b>	<b>OUT01</b>	<b>A</b>	<b>NONE</b>
2864435 ≙ ...-PT100-UI	2 ≙ 2-wire 3 ≙ 3-wire 4 ≙ 4-wire	0 -10 -20 -30 -40 -50 -100 -150	Range (increment) 0...100 (5 K) 110...300 (10 K) 320...700 (20 K) 750...850 (50 K)	OUT01 ≙ 0...20 mA OUT02 ≙ 4...20 mA OUT03 ≙ 0...10 V OUT05 ≙ 0...5 V OUT06 ≙ 1...5 V OUT07 ≙ 20...0 mA OUT08 ≙ 20...4 mA OUT09 ≙ 10...0 V	A B C D	NONE ≙ Without factory YES ≙ With factory calibration certificate (fee)  YESPLUS ≙ Factory calibration certificate with 5 measuring points (fee)
2864736 ≙ ...-PT100-UI-SP						

1) Failure information (depends on the output signal range):

	Measured value overrange			Open circuit		
	0...20 mA	4...20 mA	0...10 V	0...20 mA	4...20 mA	0...10 V
<b>A</b>	20,5 mA	20,5 mA	10,25 V	21 mA	21 mA	10,5 V
<b>B</b>	20,5 mA	20,5 mA	10,25 V	21 mA	21 mA	10,5 V
<b>C</b>	20 mA	20 mA	10 V	21 mA	21 mA	10,5 V
<b>D</b>	20 mA	20 mA	10 V	0 mA	4 mA	0 V

	Measured value underrange			Short circuit		
	0...20 mA	4...20 mA	0...10 V	0...20 mA	4...20 mA	0...10 V
<b>A</b>	0 mA	4 mA	0 V	0 mA	4 mA	0 V
<b>B</b>	0 mA	3,5 mA	0 V	0 mA	3 mA	0 V
<b>C</b>	0 mA	4 mA	0 V	21 mA	21 mA	10,5 V
<b>D</b>	0 mA	4 mA	0 V	0 mA	4 mA	0 V

## 4 Technical data

### Input

Configurable/programmable	Yes
Sensor type	Pt 100 (IEC 60751/EN 60751)
Sensor input current	1 mA (constant)
Max. permissible overall conductor resistance	10 $\Omega$ (Per cable)
Measuring range span	min. 50 K
Connection method	2, 3, 4-wire

### Output

Voltage output signal	0 V ... 10 V 10 V ... 0 V 0 V ... 5 V 1 V ... 5 V
Max. voltage output signal	Approx. 12.5 V
Non-load voltage	Approx. 12.5 V
Current output signal	4 mA ... 20 mA 20 mA ... 0 mA 20 mA ... 4 mA 0 mA ... 20 mA (please indicate if different setting when ordering)
Max. current output signal	23 mA
Configurable/programmable	Yes, preconfigured
Short-circuit current	Approx. 10 mA
Load/output load voltage output	$\geq 10$ k $\Omega$
Ripple	< 20 mV <sub>PP</sub> (at 10 k $\Omega$ )
Load/output load current output	< 500 $\Omega$ (at 20 mA)

### Supply

Nominal supply voltage	24 V DC
Supply voltage range	19.2 V DC ... 30 V DC (to bridge the supply voltage, the DIN rail connector (ME 6,2 TBUS-2 1,5/5-ST-3,81 GN, Order No. 2869728) can be used. It can be snapped onto a 35 mm DIN rail according to EN 60715)
Max. current consumption	< 21 mA (at 24 V DC)
Power consumption	< 500 mW

### General data

Transmission error in the set measuring range	((100 K / set measurement range [K]) + 0.1)%
Transmission error in the full measuring range	$\leq 0,2$ %
Maximum temperature coefficient	< 0.02 %/K
Step response (0–99%)	< 160 ms
Electrical isolation	Basic insulation according to EN 61010
Surge voltage category	II
Mounting position	Any
Degree of protection	IP20
Pollution degree	2
Rated insulation voltage	50 V AC/DC
Test voltage, input/output/supply	1.5 kV (50 Hz, 1 min.)
Dimensions W / H / D	6.2 mm / 93.1 mm / 102.5 mm
Type of housing	PBT green

Connection data	Screw connection	Spring-cage conn.
Conductor cross section, solid	0.2 mm <sup>2</sup> ... 2.5 mm <sup>2</sup>	0.2 mm <sup>2</sup> ... 2.5 mm <sup>2</sup>
Conductor cross section, stranded	0.2 mm <sup>2</sup> ... 2.5 mm <sup>2</sup>	0.2 mm <sup>2</sup> ... 2.5 mm <sup>2</sup>
Stripping length	12 mm	8 mm

### Ambient conditions

Ambient temperature (operation)	-20 °C ... 65 °C
Ambient temperature (storage/transport)	-40 °C ... 85 °C

### Conformance with EMC Directive 2004/108/EC

Noise immunity according to EN 61000-6-2
Noise emission according to EN 61000-6-4

### Conformance / approvals

Conformance	CE-compliant
ATEX	⊕ II 3 G Ex nA IIC T4 Gc X
UL, USA / Canada	UL 508 Recognized
UL, USA / Canada	Class I, Div. 2, Groups A, B, C, D T5
Shipbuilding	GL EMC 2 D

## 5 Safety regulations and installation notes

### 5.1 Installation notes

- The category 3 device is suitable for installation in the zone 2 potentially explosive area. It fulfills the requirements of EN 60079-0:2009 and EN 60079-15:2010.
- Installation, operation, and maintenance may only be carried out by qualified electricians. Follow the installation instructions described. When installing and operating the device, the applicable regulations and safety directives (including national safety directives), as well as general technical regulations, must be observed. The technical data is provided in this package slip and on the certificates (conformity assessment, additional approvals where applicable).
- It is not permissible to open or modify the device. Do not repair the device yourself but replace it with an equivalent device. Repairs may only be carried out by the manufacturer. The manufacturer is not liable for damage resulting from violation.
- The IP20 degree of protection (IEC 60529/EN 60529) of the device is intended for use in a clean and dry environment. Do not subject the device to any load that exceeds the described limits.
- The device is not designed for use in atmospheres with a danger of dust explosions.

### 5.2 Installation in the Ex area (zone 2)

- Observe the specified conditions for use in potentially explosive areas.
- The device must be installed in a housing (control or distributor box) which meets the requirements of EN 60079-15 and provides at least IP54 (EN 60529) degree of protection.
- During installation and when connecting the supply and signal circuits, observe the requirements of EN 60079-14. Devices may only be connected to circuits in zone 2 if they are suitable for operation in Ex zone 2 and for the prevailing conditions at the place of use.
- In potentially explosive areas, terminals may only be snapped onto or off the DIN rail connector and wires may only be connected or disconnected when the power is switched off.
- The device must be stopped and immediately removed from the Ex area if it is damaged, has been subjected to an impermissible load, has been stored incorrectly, or if it malfunctions.
- You can download the latest documents for these devices from [www.phoenixcontact.net/catalog](http://www.phoenixcontact.net/catalog).

## 6 Installation

### 6.1 Connection notes



**NOTE: Electrostatic discharge!**

The device contains components that can be damaged or destroyed by electrostatic discharge. When handling the device, observe the necessary safety precautions against electrostatic discharge (ESD) according to EN 61340-5-1 and EN 61340-5-2.

### 6.2 Structure

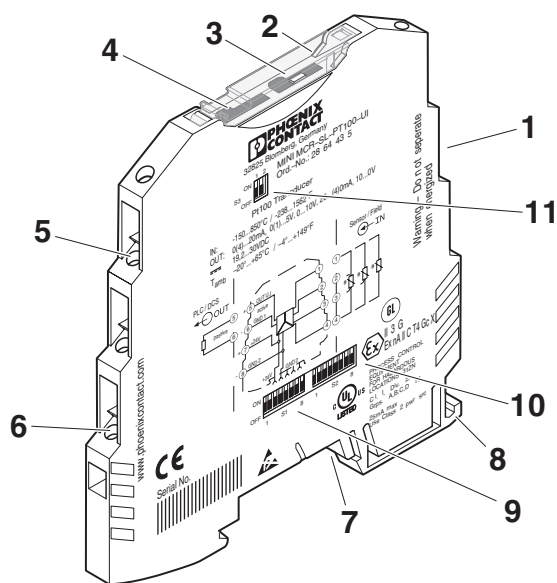

Figure 1 Structure

1. Input: Pt 100 resistance thermometer
2. Cover
3. Diagnostics LED
4. Groove for ZBF 6 zack marker strip
5. Output: Standard signals
6. Supply voltage
7. Connection option for DIN rail connector
8. Universal snap-on foot for EN DIN rails
9. DIP switch S1
10. DIP switch S2
11. DIP switch S3

### 6.3 Block diagram

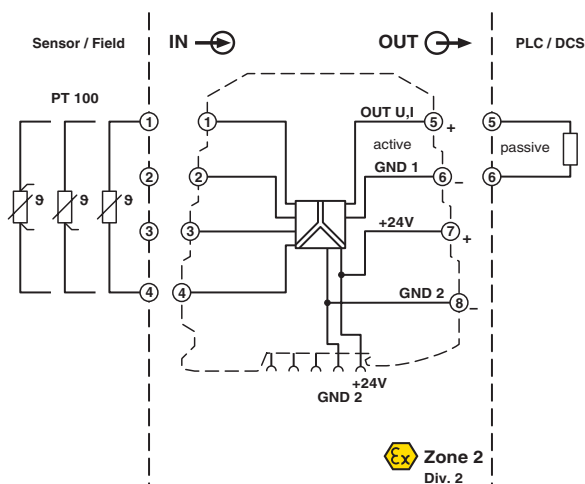

Figure 2 Block diagram

### 6.4 Power supply



**NOTE:** Never connect the supply voltage directly to the DIN rail connector. It is not permitted to draw power from the DIN rail connector or from individual modules.

#### Supply via the MINI Analog Module

Where the total current consumption of the aligned modules does not exceed 400 mA, the power can be supplied directly at the connection terminal blocks of the module.

A 400 mA fuse should be connected upstream.

#### Supply via a power terminal block

The MINI MCR-SL-PTB power terminal block (Order No. 2864134) or the MINI MCR-SL-PTB-SP power terminal block (Order No. 2864147), which are the same shape, are used to feed the supply voltage to the DIN rail connector.

A 2 A fuse should be connected upstream.

#### Supply via a system power supply unit

The system power supply unit with 1.5 A output current connects the DIN rail connector to the supply voltage and can thus be used to supply several modules from the mains.

- MINI-SYS-PS-100-240AC/24DC/1.5 (Order No. 2866983)
- Potentially explosive areas:  
MINI-PS-100-240AC/24DC/1.5/EX (Order No. 2866653)

6.5 Assembly

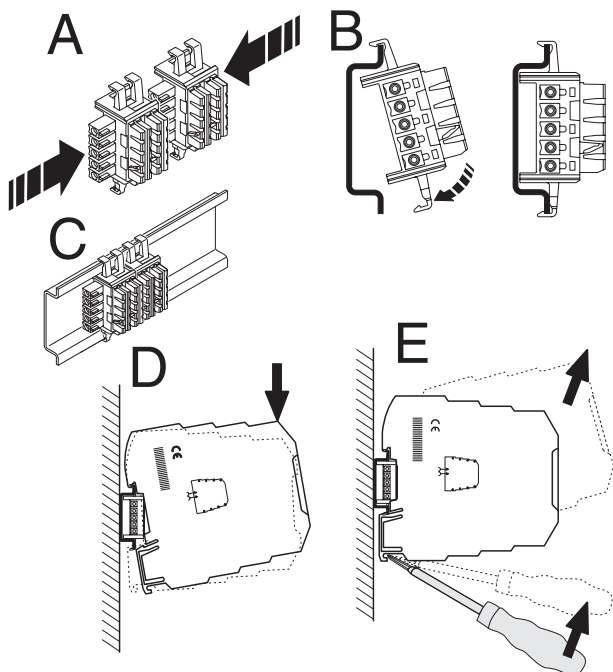

Figure 3 Mounting and removing

- Mount the module on a 35 mm DIN rail according to EN 60715.
- When using the DIN rail connector, first place it into the DIN rail (see A – C). It is used to bridge the power supply. It is also absolutely vital that you snap the module and the DIN rail connector into position in the correct direction: the snap-on foot should be at the bottom and the connector on the left.

6.6 Connecting the wires

The MINI MCR-SL-PT100-UI-... is available in two connection variants:

- Screw terminal blocks (MINI MCR-SL-PT100-UI)
- Spring-cage terminal blocks (MINI MCR-SL-PT100-UI-SP)

Screw Connection

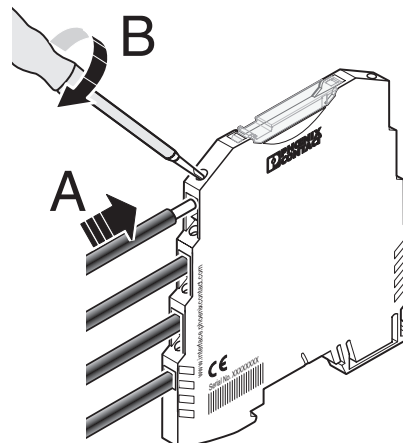

Figure 4 Screw connection

- Insert the wire into the corresponding connection terminal block.
- Use a screwdriver to tighten the screw in the opening above the connection terminal block.

Spring-cage connection:

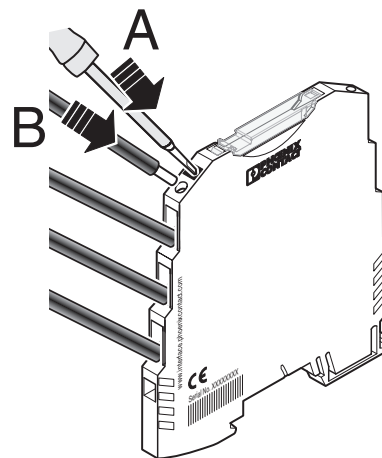

Figure 5 Spring-cage connection

- Insert a screwdriver into the opening above the connection terminal block.
- Insert the wire into the corresponding connection terminal block.

## 7 Configuration

If the modules are not configured (all DIP switches set to pos. 0), the module does not have a defined function until the DIP switches have been set.



To order a product with an order configuration, please enter the desired configuration by referring to the order key.

DIP switch S1 specifies the connection method, output signal range, and the start of the measuring range.

DIP switch S2 specifies the measuring range final value and error evaluation.

DIP switch S2 can be used to select the voltage and current output.

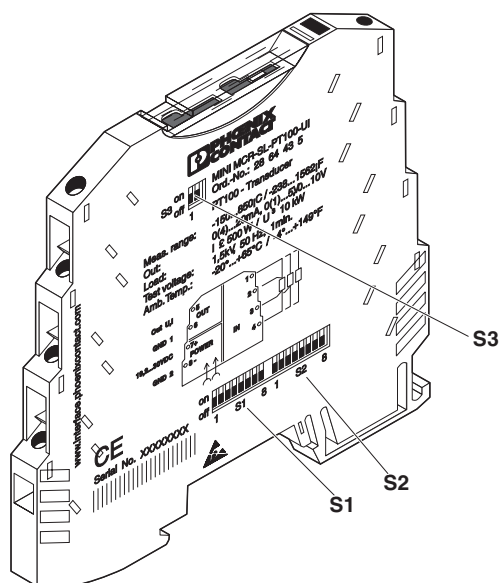

Figure 6 Location of the DIP switches

7.1 Configuration table

DIP S1		Connection method		Output signal range OUT			Start temperature			
1	2	3	4	5	6	7	8	[°C]	[°F]	
								0	32	
•								-10	14	
	•							-20	-4	
•	•							-30	-22	
			•					-40	-40	
			•	•				-50	-58	
			•	•				-100	-148	
			•	•				-150	-238	

DIP S2						Final temperature	
1	2	3	4	5	6	[°C]	[°F]
						0	32
•						5	41
	•					10	50
•	•					15	59
		•				20	68
•	•					25	77
		•	•			30	86
•	•	•				35	95
			•			40	104
•	•	•				45	113
		•	•			50	122
•	•	•				55	131
			•	•		60	140
•	•	•				65	149
		•	•			70	158
•	•	•				75	167
			•			80	176
•			•			85	185
		•				90	194
•	•	•				95	203
			•	•		100	212
•	•	•				110	230
		•	•			120	248
•	•	•				130	266
			•	•		140	284
•	•	•				150	302
		•	•			160	320
•	•	•				170	338
			•	•		180	356
•	•	•				190	374
		•	•			200	392
•	•	•				210	410
			•			220	428
•						230	446
		•				240	464
•	•					250	482
			•			260	500
•	•					270	518
		•	•			280	536
•	•	•				290	554
			•	•		300	572
•						320	608
		•	•			340	644
•	•	•				360	680
			•	•		380	716
•	•	•				400	752
		•	•			420	788
•	•	•				440	824
			•	•		460	860
•						480	896
		•	•			500	932
•	•					520	968
			•	•		540	1004
•	•	•				560	1040
		•	•			580	1076
•	•	•				600	1112
			•	•		620	1148
•	•	•				640	1184
		•	•			660	1220
•	•	•				680	1256
			•	•		700	1292
•	•	•				750	1382
		•	•			800	1472
•	•	•				850	1562

DIP S2		7	8	Cable break	Measuring range overrange	Measuring range underrange	Short circuit
A				Measuring range final value +5%	Measuring range final value +2.5%	Measuring range start value	Measuring range start value
B	•			Measuring range final value +5%	Measuring range final value +2.5%	Measuring range start value -12.5%	Measuring range start value -25%
C		•		Measuring range final value +5%	Measuring range final value	Measuring range start value	Measuring range final value +5%
D		•	•	Measuring range start value	Measuring range final value	Measuring range start value	Measuring range start value

DIP S3		1	2	OUT
•				0 ... 20 mA, 4 ... 20 mA, 20 ... 0 mA, 20 ... 4 mA
	•			0 ... 10 V, 10 ... 0 V, 0 ... 5 V, 1 ... 5 V

- ≙ ON
- ≙ OFF

## 8 Diagnostics LED

The LED indicates the following error states:

- LED flashes: Measuring range span < 50 K
- LED ON: Open circuit on the sensor side
- LED ON: Short-circuit on the sensor side
- LED ON: Measuring range overrange
- LED ON: Measuring range underrange

## 9 Connection/application example

### 2-Wire Connection Method

For short distances (< 10 m). The RL1 and RL2 cable resistance are incorporated directly into the measurement result.

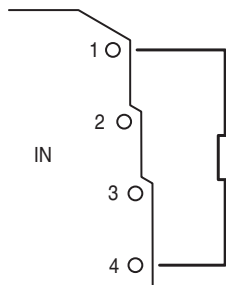

Figure 7 Connection example

### 4-Wire Connection Method

For long distances between the Pt 100-Sensor and the MINI analog module and different cable resistances ( $RL1 \neq RL2 \neq RL3 \neq RL4$ ).

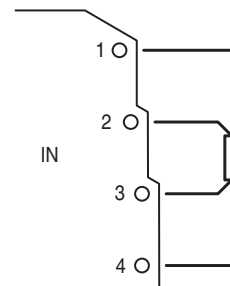

Figure 9 Connection example

### 3-Wire Connection Method

For long distances between the Pt100 sensor and the MINI Analog module. All cable resistances must have exactly the same values to compensate for cable resistances ( $RL1 = RL2 = RL3$ ).

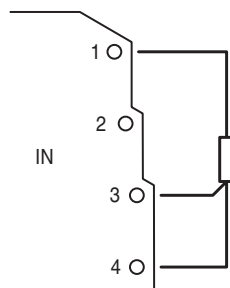

Figure 8 Connection example



# SCATTERGOOD & JOHNSON LTD

ELECTRICAL ENGINEERING & FLUID CONTROL DISTRIBUTORS

Est.1899

At Scattergood & Johnson Ltd, we pride ourselves on being a technical distributor to specialist industries.

Working with a range of quality product suppliers across a number of specialist markets, we are not your average 'box shifter' - we are your technical and supply chain partner.

We fully support every product we sell - for free! Our internal team and external sales engineers can answer any product or application question, no matter the complexity.

Backing up this technical ability is a range of 50,000+ products available from stock for nationwide next day delivery (same day if required!), or you can collect what you need from any of our trade counters around the UK.

Select your specialist interest below to learn more about how we can help.



Online, In Branch and On the Road - Scattergood & Johnson Ltd, there when you need us.

# [www.scatts.co.uk](http://www.scatts.co.uk)