

# MINI MCR-SL-RPS-I-I

## Repeater power supply, active

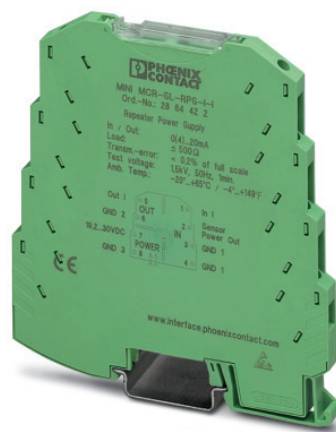

Data sheet  
101947\_en\_07

© PHOENIX CONTACT 2011-12-20

## 1 Description

The 6.2 mm wide MINI MCR-SL-RPS-I-I... repeater power supply supplies transmitters in the field and electrically isolates the input signal from the output signal. The module can be used in both isolator and repeater power supply operation.

Electrically isolated 0...20 mA or 4...20 mA standard analog signals are available on the input and output side.

Power (19.2 V DC to 30 V DC) can be supplied either via the connection terminals on the modules or in conjunction with the DIN rail connector.

### Features

- 0...20 mA or 4...20 mA input and output signal range
- Approval for Ex-zone 2 (nA)
- Supply to passive sensors and transmitters
- Screw or spring-cage connection can be provided



#### Attention: Correct usage in potentially explosive areas

The module is a category 3 item of electrical equipment. It is absolutely vital to follow the instructions provided here during installation and observe the information in the "Safety regulations and installation notes".



Make sure you always use the latest documentation.

It can be downloaded from the product at [www.phoenixcontact.net/catalog](http://www.phoenixcontact.net/catalog).



This data sheet is valid for all products listed on the following page:

---

<b>2</b>	<b>Table of contents</b>	
1	Description .....	1
2	Table of contents .....	2
3	Ordering data .....	3
4	Technical data .....	3
5	Safety regulations and installation notes.....	5
	5.1 Installation notes .....	5
6	Installation .....	6
	6.1 Connection notes .....	6
	6.2 Structure .....	6
	6.3 Block diagram.....	6
	6.4 Power supply.....	6
	6.5 Assembly.....	7
	6.6 Connecting the wires .....	7
7	Connection/application example .....	8

### 3 Ordering data

Description	Type	Order No.	Pcs. / Pkt.
MCR repeater power supplies, screw connection, input signal: (0)4..20 mA, output signal: (0)4..20 mA	MINI MCR-SL-RPS-I-I	2864422	1
MCR repeater power supplies, spring-cage connection, input signal: (0)4..20 mA, output signal: (0)4..20 mA	MINI MCR-SL-RPS-I-I-SP	2864752	1
Accessories	Type	Order No.	Pcs. / Pkt.
DIN rail connector (TBUS), 5-pos., for bridging the supply voltage, can be snapped onto NS 35/... DIN rails according to EN 60715	ME 6,2 TBUS-2 1,5/5-ST-3,81 GN	2869728	10
MCR power terminal block for supplying several MINI Analog modules via the DIN rail connectors, with screw connection, current consumption up to max. 2 A	MINI MCR-SL-PTB	2864134	1
MCR power terminal block for supplying several MINI-ANALOG modules via the DIN rail connectors, with spring-cage connection, current consumption up to max. 2 A	MINI MCR-SL-PTB-SP	2864147	1
DIN rail power supply unit, primary-switched mode, slim design, output: 24 V DC / 1.5 A	MINI-SYS-PS-100-240AC/24DC/1.5	2866983	1
DIN rail power supply unit, primary-switched mode, slim design, output: 24 V DC / 1.5 A, ATEX approval	MINI-PS-100-240AC/24DC/1.5/EX	2866653	1
Eight MINI analog signal converters with screw connection method can be connected to a control system using a system adapter and system cabling with a minimum of wiring and very low error risk.	MINI MCR-SL-V8-FLK 16-A	2811268	1
Fold up transparent cover for MINI MCR modules with additional labeling option using insert strips and flat Zack marker strip 6.2 mm	MINI MCR DKL	2308111	10
Label for extended marking of MINI MCR modules in connection with the MINI MCR-DKL	MINI MCR-DKL-LABEL	2810272	10

### 4 Technical data

Input	
Description of the input	Current input (sensor circuit)
Current input signal	4 mA ... 20 mA (repeater power supply and isolator operation) 0 mA ... 20 mA (isolator operation)
Max. current input signal	28 mA
Input resistance current input	Approx. 50 Ω
Transmitter supply voltage	(U <sub>B</sub> - max. 4.5 V for load 0 mA ... 20 mA)
Transmitter supply voltage range	14.7 V DC ... 25.5 V DC
Output	
Output description	Current output
Non-load voltage	Approx. 12.5 V
Current output signal	4 mA ... 20 mA (repeater power supply and isolator operation) 0 mA ... 20 mA (isolator operation)
Max. current output signal	28 mA
Ripple	< 20 mV <sub>rms</sub> (at 500 Ω)
Load/output load current output	≤ 500 Ω (at I = 20 mA)

**Supply**

Nominal supply voltage	24 V DC
Supply voltage range	19.2 V DC ... 30 V DC (to bridge the supply voltage, the DIN rail connector (ME 6,2 TBUS-2 1,5/5-ST-3,81 GN, Order No. 2869728) can be used. It can be snapped onto a 35 mm DIN rail according to EN 60715)
Power consumption	< 900 mW (at 24 V DC and in repeater power supply operation) < 600 mW (at 24 V DC and in isolator operation)

**General data**

Limit frequency (3 dB)	Approx. 100 Hz
Transmission error, typical	≤ 0.1 % (of final value)
Maximum transmission error	≤ 0.2 % (of final value)
Temperature coefficient, typical	< 0.002 %/K
Maximum temperature coefficient	< 0.01 %/K
Step response (10-90%)	Approx. 3.5 ms
Electrical isolation	Basic insulation according to EN 61010
Surge voltage category	II
Mounting position	Any
Degree of protection	IP20
Pollution degree	2
Rated insulation voltage	50 V AC/DC
Test voltage, input/output/supply	1.5 kV (50 Hz, 1 min.)
Dimensions W / H / D	6.2 mm / 93.1 mm / 102.5 mm
Type of housing	PBT green

**Connection data****Screw connection****Spring-cage conn.**

Conductor cross section, solid	0.2 mm <sup>2</sup> ... 2.5 mm <sup>2</sup>	0.2 mm <sup>2</sup> ... 2.5 mm <sup>2</sup>
Conductor cross section, stranded	0.2 mm <sup>2</sup> ... 2.5 mm <sup>2</sup>	0.2 mm <sup>2</sup> ... 2.5 mm <sup>2</sup>
Stripping length	12 mm	8 mm

**Ambient conditions**

Ambient temperature (operation)	-20 °C ... 60 °C
Ambient temperature (storage/transport)	-40 °C ... 85 °C

**Conformance with EMC Directive 2004/108/EC**

Noise immunity according to EN 61000-6-2
Noise emission according to EN 61000-6-4

**Conformance / approvals**

Conformance	CE-compliant
ATEX	⊕ II 3 G Ex nA IIC T4 Gc X
UL, USA / Canada	UL 508 Recognized
UL, USA / Canada	Class I, Div. 2, Groups A, B, C, D T5
Shipbuilding	GL EMC 2 D

## 5 Safety regulations and installation notes

### 5.1 Installation notes

- The category 3 device is suitable for installation in the zone 2 potentially explosive area. It fulfills the requirements of EN 60079-0:2009 and EN 60079-15:2010.
- Installation, operation, and maintenance may only be carried out by qualified electricians. Follow the installation instructions described. When installing and operating the device, the applicable regulations and safety directives (including national safety directives), as well as general technical regulations, must be observed. The technical data is provided in this package slip and on the certificates (conformity assessment, additional approvals where applicable).
- It is not permissible to open or modify the device. Do not repair the device yourself but replace it with an equivalent device. Repairs may only be carried out by the manufacturer. The manufacturer is not liable for damage resulting from violation.
- The IP20 degree of protection (IEC 60529/EN 60529) of the device is intended for use in a clean and dry environment. Do not subject the device to any load that exceeds the described limits.
- The device is not designed for use in atmospheres with a danger of dust explosions.

### Installation in the Ex area (zone 2)

- Observe the specified conditions for use in potentially explosive areas.
- The device must be installed in a housing (control or distributor box) which meets the requirements of EN 60079-15 and provides at least IP54 (EN 60529) degree of protection.
- During installation and when connecting the supply and signal circuits, observe the requirements of EN 60079-14. Devices may only be connected to circuits in zone 2 if they are suitable for operation in Ex zone 2 and for the prevailing conditions at the place of use.
- In potentially explosive areas, terminals may only be snapped onto or off the DIN rail connector and wires may only be connected or disconnected when the power is switched off.
- The device must be stopped and immediately removed from the Ex area if it is damaged, has been subjected to an impermissible load, has been stored incorrectly, or if it malfunctions.
- You can download the latest documents for these devices from [www.phoenixcontact.net/catalog](http://www.phoenixcontact.net/catalog).

## 6 Installation

### 6.1 Connection notes



**Attention: Electrostatic discharge!**

The device contains components that can be damaged or destroyed by electrostatic discharge. When handling the device, observe the necessary safety precautions against electrostatic discharge (ESD) according to EN 61340-5-1 and EN 61340-5-2.

### 6.2 Structure

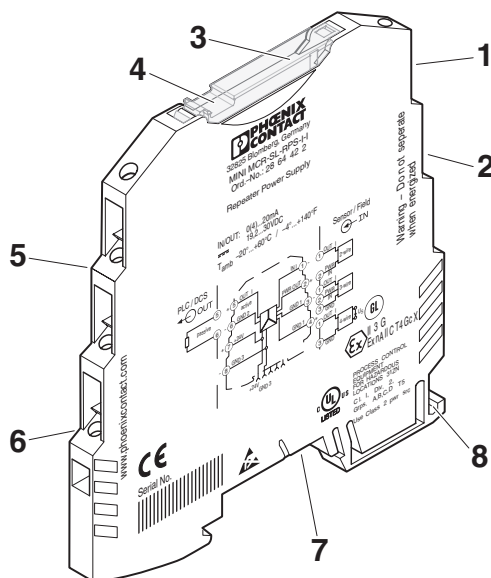

Figure 1 Structure

1. Output: Transmitter supply voltage
2. Input: Standard signals
3. Cover
4. Groove for ZBF 6 zack marker strip
5. Output: Standard signals
6. Supply voltage
7. Connection option for DIN rail connector
8. Universal snap-on foot for EN DIN rails

### 6.3 Block diagram

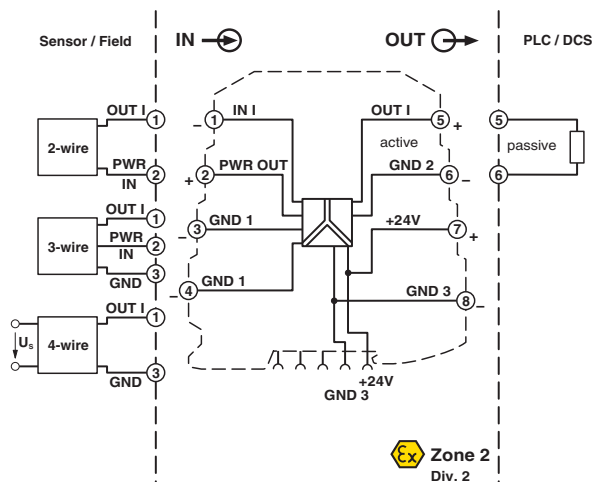

Figure 2 Block diagram

### 6.4 Power supply



**ATTENTION:**

Never connect the supply voltage directly to the DIN rail connector. It is not permitted to draw power from the DIN rail connector or from individual modules.

#### Supply via the module

Where the total current consumption of the aligned modules does not exceed 400 mA, the power can be supplied directly at the connection terminal blocks of the module.

A 400 mA fuse should be connected upstream.

#### Supply via a power terminal block

The MINI MCR-SL-PTB power terminal block (Order No. 2864134) or the MINI MCR-SL-PTB-SP power terminal block (Order No. 2864147), which are the same shape, are used to feed the supply voltage to the DIN rail connector.

A 2 A fuse should be connected upstream.

#### Supply via a system power supply unit

The system power supply unit with 1.5 A output current connects the DIN rail connector to the supply voltage and can therefore be used to supply several modules from the mains.

- MINI-SYS-PS-100-240AC/24DC/1.5 (Order No. 2866983)
- Potentially explosive areas:  
MINI-PS-100-240AC/24DC/1.5/EX (Order No. 2866653)

### 6.5 Assembly

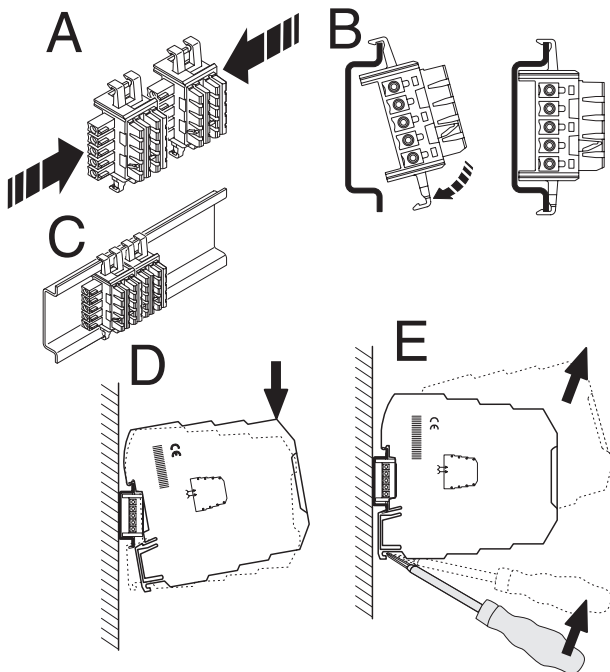

Figure 3 Mounting and removing

- Mount the module on a 35 mm DIN rail according to EN 60715.
- When using the DIN rail connector, first place it into the DIN rail (see A – C). It is used to bridge the power supply. It is also absolutely vital that you snap the module and the DIN rail connector into position in the correct direction: the snap-on foot should be at the bottom and the connector on the left.

### 6.6 Connecting the wires

The MINI MCR-SL-RPS-I-I... is available with two types of connection

- Screw terminal blocks (MINI MCR-SL-RPS-I-I)
- Spring-cage terminal blocks (MINI MCR-SL-RPS-I-I-SP)

#### Screw connection:

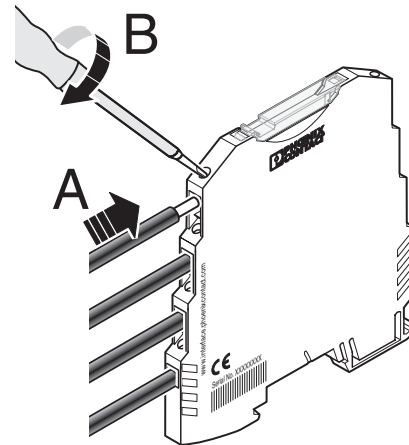

Figure 4 Screw connection

- Insert the wire into the corresponding connection terminal block.
- Use a screwdriver to tighten the screw in the opening above the connection terminal block.

#### Spring-cage connection:

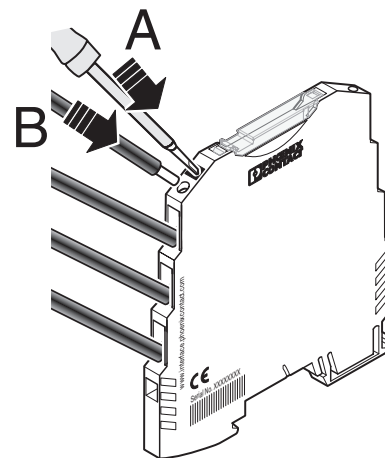

Figure 5 Spring-cage connection

- Insert a screwdriver into the opening above the connection terminal block.
- Insert the wire into the corresponding connection terminal block.

## 7 Connection/application example

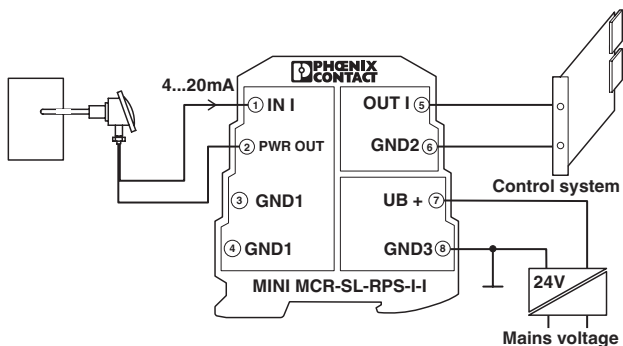

Figure 6 Repeater power supply operation with a passive sensor

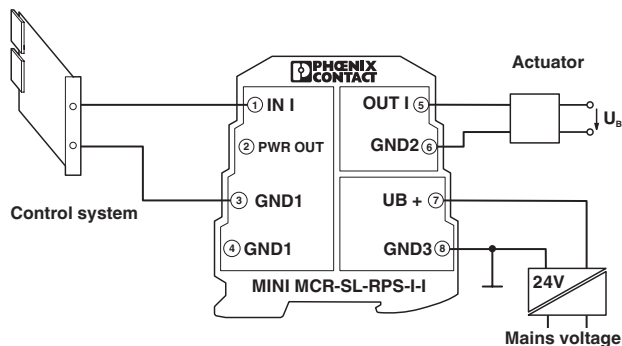

Figure 8 Isolator operation at the analog output module

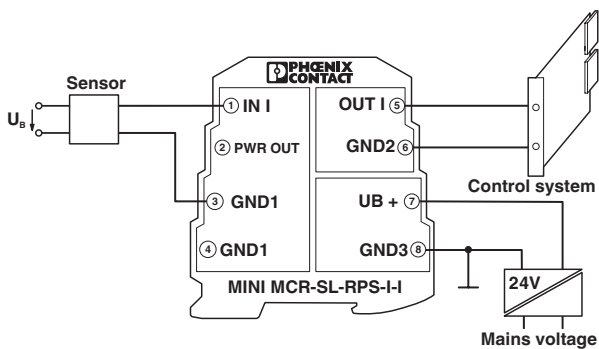

Figure 7 Isolator operation with an active sensor

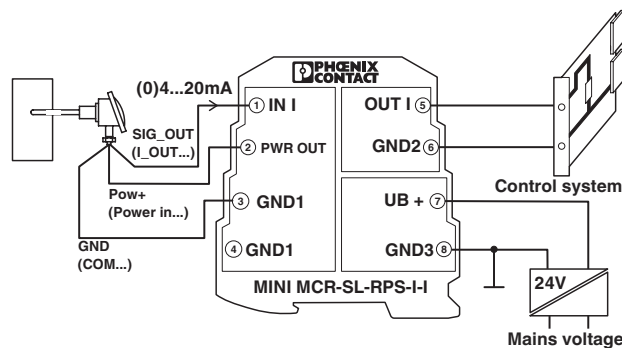

Figure 9 3-wire connection with passive sensor



# SCATTERGOOD & JOHNSON LTD

ELECTRICAL ENGINEERING & FLUID CONTROL DISTRIBUTORS

Est.1899

At Scattergood & Johnson Ltd, we pride ourselves on being a technical distributor to specialist industries.

Working with a range of quality product suppliers across a number of specialist markets, we are not your average 'box shifter' - we are your technical and supply chain partner.

We fully support every product we sell - for free! Our internal team and external sales engineers can answer any product or application question, no matter the complexity.

Backing up this technical ability is a range of 50,000+ products available from stock for nationwide next day delivery (same day if required!), or you can collect what you need from any of our trade counters around the UK.

Select your specialist interest below to learn more about how we can help.



Online, In Branch and On the Road - Scattergood & Johnson Ltd, there when you need us.

# [www.scatts.co.uk](http://www.scatts.co.uk)