

MACX MCR-EX-T-UI-UP...



Temperature transducer with intrinsically safe input for temperature sensors, voltage signals, resistance-type sensors, and potentiometers

Data sheet
104601_en_07

© PHOENIX CONTACT 2019-04-29

1 Description

The programmable temperature transducer is designed for operating intrinsically safe temperature sensors (RTD and thermocouples), voltage signal and resistance-type sensors as well as potentiometers installed in the Ex area. The measured values are converted into a linear current or voltage signal for driving a non-intrinsically-safe load.

The temperature transducer is either configured with a standard configuration or with an order-specific configuration in accordance with an order key and is delivered calibrated ready for operation (-C versions).

In addition to an analog current and voltage output, the module also has a switching output. The power supply has been designed as a wide range power supply.

The devices can be installed in Ex zone 2 in the protection type "n" (EN 60079-15).

Features such as sensor type, connection technology, measuring range, measuring unit, filter, alarm signal and output range can be configured using the IFS-CONF software and a device-specific DTM (Device Type Manager).



WARNING: Explosion hazard

The device is an item of associated equipment (category 1) with "intrinsic safety" type of protection and can be installed in zone 2 potentially explosive areas as a category 3 device. It satisfies the requirements of the following standards. Comprehensive details are to be found in the EU Declaration of Conformity which is enclosed and also available on our website in the latest version:

EN/IEC 60079-0, EN/IEC 60079-11 and EN/IEC60079-15

When installing and operating the device, the applicable safety directives (including national safety directives), accident prevention regulations, as well as general technical regulations must be observed.



Make sure you always use the latest documentation.

It can be downloaded at phoenixcontact.net/products.

This document is valid for the products listed in the "Ordering data".

Features

- Temperature sensors (RTDs and thermocouples), resistance-type sensors, and potentiometers can be used in applications up to SIL 2.
- Voltage signals can be used with restrictions in applications up to SIL 2.
- Intrinsically safe inputs [Ex ia] IIC
- Current and voltage output
- Switching output (1 PDT relay)
- Configuration via software (FDT/DTM) or operator interface (IFS-OP-UNIT)
- Up to SIL 2 according to EN 61508 on output
4 ... 20 mA
- PL d according to EN ISO 13849-1
- 3-way electrical isolation
- Installation in zone 2 permitted
- Wide range power supply 19.2 ... 253 V AC/DC
- With screw or spring-cage connection (Push-in Technology)

2 Table of contents

1	Description.....	1
2	Table of contents	3
3	Ordering data.....	6
4	Order key	9
5	Technical data	10
6	Safety regulations and installation notes.....	13
6.1	Content of the EU Declaration of Conformity.....	13
6.2	Safety notes.....	13
6.3	Installation notes	13
6.4	Intrinsic safety.....	13
6.5	Installation in Zone 2	14
6.6	Potentially dust-explosive areas	14
6.7	Safety-related applications (SIL, PL)	14
6.8	UL note.....	14
7	Minimum spans and measuring accuracy.....	15
7.1	Input for Pt RTDs and Ni RTDs.....	15
7.2	Input for Cu RTDs	15
7.3	Input for Ni 1000 (Landis & Gyr), KTY 81-110, KTY 84-130 (Philips).....	15
7.4	Input for thermocouples	15
7.5	Cold junction error.....	15
7.6	Input for voltage signals	15
7.7	Resistance-type sensors and resistors.....	15
7.8	Potentiometer	16
7.9	Output signals	16
8	Installation	17
8.1	Basic circuit diagrams	17
8.2	Structure.....	17
8.3	Dimensions.....	17
8.4	Mounting	18
8.5	Connection of the cables	18
8.6	Power supply	18
8.7	Sensor types	19
8.7.1	Thermocouple (TC) with internal cold junction compensation	19
8.7.2	Thermocouple (TC) with external or without cold junction compensation	19
8.7.3	Voltage input	19

8.7.4	Potentiometer	19
8.7.5	Resistance temperature detector (RTD).....	19
8.7.6	Resistance measurement.....	19
8.8	Notes on using thermocouples	19
8.8.1	Cold junction compensation	19
8.8.2	Thermocouple types.....	20
8.9	Current output	20
8.10	Voltage output	20
8.11	Switching output.....	21
8.12	Switching output behavior with manual acknowledgement (latching).....	22
8.12.1	Switching behavior (2): undertemperature limit (\leq SPH).....	22
8.12.2	Switching behavior (3): overtemperature limit (\geq SPH).....	22
8.12.3	Switching behavior (4): undertemperature limit with hysteresis (\leq SPL).....	23
8.12.4	Switching behavior (5): overtemperature limit with hysteresis (\geq SPH).....	23
8.12.5	Switching behavior (6): temperature range limit (\leq SPL and \geq SPH)	24
8.12.6	Switching behavior (7): temperature range limit (\geq SPL and \leq SPH)	24
8.13	Monitoring function	25
8.14	Operating modes	25
8.14.1	SIL ON / SIL OFF	25
8.14.2	Service mode	25
9	Configuration	26
9.1	Delivery state / standard configuration	26
9.2	Zero adjust, adjustment via DIP switch S2 and S3 (only possible with SIL OFF)	26
9.3	Span adjust, adjustment via DIP switch 2 and 3 (only possible with SIL OFF)	26
9.4	Force output.....	27
9.5	Cable compensation, 2-wire RTD or RTD 1 with 2 x RTD	27
9.6	Cable compensation RTD 2 with 2 x RTD or TC with external cold junction compensation (TC + CJ external).....	27
9.7	Automatic potentiometer adjustment (teach-in).....	27
9.8	Manual acknowledgement of switching outputs (latch function).....	27
9.9	LED status indicators	28
10	Password	28
11	Configuration with the service PC	29
11.1	System requirements	29
11.2	Configuring the user characteristic curve	29
12	Comparison of the safety data	29
13	Application examples.....	30
13.1	Current output	30
13.2	Voltage output	30

13.3	Switching output.....	31
14	Flow chart, operator interface	31
14.1	Menu structure	32
14.2	Key for start screen.....	33
14.3	Key for SETTINGS - MENU	33
14.4	Key for SETTINGS - Configure	33
14.5	Key for SETTINGS - Service	34
14.6	Key for SETTINGS - Save	34
14.7	Key for input	35
14.7.1	Key for input configuration (analog input)	35
14.8	Key for output	37
14.8.1	Key for output configuration (analog output)	37
14.9	Key for error behavior	38
14.10	Key for switching output	38
15	Error codes of the IFS-OP-UNIT operator interface	38
Appendix	1
A1	Safety-related applications (SIL 2).....	1
A1.1	Safety function and safety requirements	1
A1.2	Requirements on safety integrity.....	2
A1.3	Configuring an SIL device	5
A1.4	Installation and startup	6
A1.5	Notes on operation	6
A1.6	Functional restrictions	6
A1.7	Recurring checks (SIL 2).....	7
A1.8	Repair	7
A1.9	Standards (SIL 2).....	7
A1.10	Abbreviations	8

3 Ordering data

Description	Type	Order No.	Pcs./Pkt.
Freely programmable Ex-i temperature transducer with analog output and 1 limit value relay, standard configuration, resistance thermometer in 2-, 3-, or 4-wire technology, thermocouples, electrical isolation, wide-range power supply, screw connection, SIL, PL.	MACX MCR-EX-T-UI-UP	2865654	1
Programmable Ex-i temperature transducer with analog output and 1 limit value relay, standard configuration, resistance thermometer in 2-, 3-, or 4-wire technology, thermocouples, electrical isolation, wide-range power supply, Push-in connection, SIL, PL.	MACX MCR-EX-T-UI-UP-SP	2924689	1
Freely programmable Ex-i temperature transducer with analog output and 1 limit value relay, order configuration, resistance thermometer in 2-, 3-, or 4-wire technology, thermocouples, electrical isolation, wide-range power supply, screw connection, SIL, PL.	MACX MCR-EX-T-UI-UP-C	2811763	1
Freely programmable Ex-i temperature transducer with analog output and 1 limit value relay, order configuration, resistance thermometer in 2-, 3-, or 4-wire technology, thermocouples, electrical isolation, wide-range power supply, Push-in connection, SIL, PL.	MACX MCR-EX-T-UI-UP-SP-C	2924692	1
Accessories	Type	Order No.	Pcs./Pkt.
The control unit facilitates straightforward parameterization and operation of the MACX MCR(-EX)-...-UI(REL)(-UP) on-site, even without software. With the copying function, other modules can be configured quickly and cost-effectively. Can be snapped onto the 35 mm module.	IFS-OP-UNIT	2811899	1
The adapter (IFS-OP-CRADLE) for the operator interface is ideal for use as a remote operator panel and display device for 17.5 mm/35 mm modules. Can be mounted directly on the DIN rail.	IFS-OP-CRADLE	2811886	1
Programming adapter with USB interface, for programming with software. The USB driver is included in the software solutions for the products to be programmed, such as measuring transducers or motor managers.	IFS-USB-PROG-ADAPTER	2811271	1
Connection terminal block for current signals +20 mA ...-20 mA for safe switching of limit values, in combination with MACX...EX-T-UI... temperature transducers.	MACX MCR-EX-I20	2905679	1
Plug for cold junction compensation for thermocouples, for safe switching of limit values, in combination with MACX ...EX-T-UI... temperature transducers.	MACX MCR-EX-CJC	2925002	1

Accessories	Type	Order No.	Pcs./Pkt.
Plastic label, Sheet, white, unlabeled, can be labeled with: BLUEMARK ID COLOR, BLUEMARK ID, BLUEMARK CLED, PLOTMARK, CMS-P1-PLOTTER, mounting type: adhesive, lettering field size: 11 x 9 mm	UC-EMLP (11X9)	0819291	10
Plastic label, can be ordered: by sheet, white, labeled according to customer specifications, mounting type: adhesive, lettering field size: 11 x 9 mm	UC-EMLP (11X9) CUS	0824547	1
Plastic label, Sheet, yellow, unlabeled, can be labeled with: BLUEMARK ID COLOR, BLUEMARK ID, BLUEMARK CLED, PLOTMARK, CMS-P1-PLOTTER, mounting type: adhesive, lettering field size: 11 x 9 mm	UC-EMLP (11X9) YE	0822602	10
Plastic label, can be ordered: by sheet, yellow, labeled according to customer specifications, mounting type: adhesive, lettering field size: 11 x 9 mm	UC-EMLP (11X9) YE CUS	0824548	1
Plastic label, Sheet, silver, unlabeled, can be labeled with: BLUEMARK ID COLOR, BLUEMARK ID, BLUEMARK CLED, PLOTMARK, CMS-P1-PLOTTER, mounting type: adhesive, lettering field size: 11 x 9 mm	UC-EMLP (11X9) SR	0828094	10
Plastic label, can be ordered: by sheet, silver, labeled according to customer specifications, mounting type: adhesive, lettering field size: 11 x 9 mm	UC-EMLP (11X9) SR CUS	0828098	1
Plastic label, Card, white, unlabeled, can be labeled with: BLUEMARK ID COLOR, BLUEMARK ID, THERMOMARK PRIME, THERMOMARK CARD 2.0, THERMOMARK CARD, mounting type: adhesive, lettering field size: 11 x 9 mm	US-EMLP (11X9)	0828789	10
Plastic label, Card, yellow, unlabeled, can be labeled with: BLUEMARK ID COLOR, BLUEMARK ID, THERMOMARK PRIME, THERMOMARK CARD 2.0, THERMOMARK CARD, mounting type: adhesive, lettering field size: 11 x 9 mm	US-EMLP (11X9) YE	0828871	10
Plastic label, Card, silver, unlabeled, can be labeled with: BLUEMARK ID COLOR, BLUEMARK ID, THERMOMARK PRIME, THERMOMARK CARD 2.0, THERMOMARK CARD, mounting type: adhesive, lettering field size: 11 x 9 mm	US-EMLP (11X9) SR	0828872	10
Device marker, Sheet, white, unlabeled, can be labeled with: TOPMARK NEO, TOPMARK LASER, mounting type: adhesive, lettering field size: 11 x 9 mm	LS-EMLP (11X9) WH	0831678	10
Device marker, Sheet, yellow, unlabeled, can be labeled with: TOPMARK NEO, TOPMARK LASER, mounting type: adhesive, lettering field size: 11 x 9 mm	LS-EMLP (11X9) YE	0831732	10
Device marker, Sheet, silver, unlabeled, can be labeled with: TOPMARK NEO, TOPMARK LASER, mounting type: adhesive, lettering field size: 11 x 9 mm	LS-EMLP (11X9) SR	0831705	10
Test plugs, with solder connection up to 1 mm ² conductor cross section, color: gray	MPS-MT	0201744	10
Insulating sleeve, color: black	MPS-IH BK	0201731	10

Accessories	Type	Order No.	Pcs./Pkt.
Insulating sleeve, color: gray	MPS-IH GY	0201728	10
Insulating sleeve, color: green	MPS-IH GN	0201702	10
Insulating sleeve, color: yellow	MPS-IH YE	0201692	10
Insulating sleeve, color: blue	MPS-IH BU	0201689	10
Insulating sleeve, color: red	MPS-IH RD	0201676	10
Insulating sleeve, color: white	MPS-IH WH	0201663	10

5 Technical data

Input data	
Sensor types (RTD) that can be used	Pt, Ni, Cu sensors: 2, 3, 4-wire
Sensor types that can be used (TC)	B, E, J, K, N, R, S, T, L, U, CA, DA, A1G, A2G, A3G, MG, LG
Potentiometer	0 Ω ... 50 kΩ
Resistor	0 Ω ... 50 kΩ
Temperature measuring range	-250 °C ... 2500 °C (Range depending on the sensor type)
Voltage	-1000 mV ... 1000 mV
Output	
Switching output	Switching output
Configurable/programmable	Yes
Contact type	1 PDT
Contact material	AgSnO ₂ , hard gold-plated
Maximum switching voltage	30 V AC (30 V DC)
Maximum inrush current	0.5 A (30 V AC) 1 A (30 V DC)
Mechanical service life	1x 10 ⁵ cycles
Output signal maximum voltage	± 11 V
Current output signal	4 mA ... 20 mA (in the case of SIL; further free configuration without SIL)
Output signal maximum current	22 mA
Load/output load voltage output	≥ 10 kΩ
Load/output load current output	≤ 600 Ω (20 mA)
Behavior in the event of a sensor error	according to NE 43 or freely configurable
General data	
Supply voltage range	24 V ... 230 V AC/DC (-20 %/+10 %, 50/60 Hz)
Typical current consumption	< 50 mA (24 V DC)
Power consumption	< 1.5 W
Maximum transmission error	0.1 % (E.g., at Pt 100, 300 K min. span)
Transmission error, total	< 0.1 % (e.g., for Pt 100, 300 K span, 4 ... 20 mA)
Maximum temperature coefficient	0.01 %/K
Step response (0–99%)	typ. 1000 ms (With SIL) typ. 700 ms (Without SIL)
Electrical isolation	4-way, between input/output/power supply/switching output
Degree of protection	IP20
Flammability rating according to UL 94	V0
Overvoltage category	II
Degree of pollution	2

General data

Status display	Green LED (supply voltage, PWR) Red LED, flashing (line, sensor error, ERR) Red LED (module error, ERR) Yellow LED (switching output)
Dimensions W/H/D	17,5 mm / 112,5 mm / 114,5 mm (MACX MCR-EX-T-UI-UP) 17,5 mm / 116 mm / 114,5 mm (MACX MCR-EX-T-UI-UP-SP)
Type of housing	PA 6.6-FR gray

Ambient conditions

Ambient temperature (operation)	-20 °C ... 65 °C
Ambient temperature (storage/transport)	-40 °C ... 85 °C
Permissible humidity (operation)	typ. 5 % ... 95 % (non-condensing)
Maximum altitude for use above sea level	≤ 2000 m

Electrical isolation

Input/output/power supply 50 Hz, 1 min., test voltage	2.5 kV
Input/output Peak value in accordance with EN 60079-11	375 V
Input/power supply Peak value in accordance with EN 60079-11	375 V
Input/switching output Peak value in accordance with EN 60079-11	375 V
Output/supply Rated insulation voltage (overvoltage category II; degree of pollution 2, safe isolation as per EN 61010-1)	300 V _{rms}

Connection data	Screw connection	Push-in connection
Conductor cross section, solid	0.2 mm ² ... 2.5 mm ²	0.2 mm ² ... 1.5 mm ²
Conductor cross section, flexible	0.2 mm ² ... 2.5 mm ²	0.2 mm ² ... 1.5 mm ²
Conductor cross section AWG	24 ... 14	24 ... 16
Stripping length	7 mm	8 mm
Tightening torque	0.5 Nm ... 0.6 Nm	

Safety data as per ATEX

Max. output voltage U _o	6 V
Max. output current I _o	7.4 mA
Max. output power P _o	11 mW
Group Max. external inductivity L _o / Max. external capacitance C _o	IIB : 100 mH / 6.8 μF ; 10 mH / 9.2 μF ; 1 mH / 15 μF
Group Max. external inductivity L _o / Max. external capacitance C _o	IIC : 100 mH / 1.3 μF ; 10 mH / 1.7 μF ; 1 mH / 2.6 μF

Safety data as per ATEX

Max. internal inductance L_i	negligible
Max. internal capacitance C_i	44 nF
Safety-related maximum voltage U_m	253 V AC/DC

Conformance with EMC directive

Noise immunity according to EN 61000-6-2
When being exposed to interference, there may be minimal deviations.

Noise emission according to EN 61000-6-4

Conformance/Approvals

Conformance	CE-compliant
ATEX (IBE _{XU} 10 ATEX 1044)	Ⓢ II (1) G [Ex ia Ga] IIC Ⓢ II (1) D [Ex ia Da] IIIC Ⓢ II 3 G Ex nA nC ic IIC T4 Gc X
IECEX (IECE _X IBE 10.0004 X)	[Ex ia Ga] IIC [Ex ia Da] IIIC Ex nA nC ic IIC T4 Gc X
UL, USA/Canada	UL 508 Listed, C.D.-No 83104549
KC-s (17-KA4BO-0411X)	[Ex ia] IIC/IIB
Shipbuilding (DNV GL TAA000020C)	B
Temperature	B
Humidity	A
Vibration	A
EMC	A
Enclosure	Required protection according to the Rules shall be provided upon installation on board
Safety Integrity Level (SIL) IEC 61508 (SEBS-A.150520/17TB)	to 2
Performance level according to ISO 13849 (SEBS-A.150520/17TB)	PLd

6 Safety regulations and installation notes

6.1 Content of the EU Declaration of Conformity

Manufacturer: PHOENIX CONTACT GmbH & Co.KG,
Flachmarktstr.8, 32825 Blomberg, Germany

Product designation:	Order No.:
MACX MCR-EX-T-UI-UP	2865654
MACX MCR-EX-T-UI-UP-SP	2924689
MACX MCR-EX-T-UI-UP-C	2811763
MACX MCR-EX-T-UI-UP-SP-C	2924692

The above mentioned product conforms with the most important requirements of the following directive(s) and their modification directives:

2006/42/EC	Machinery Directive
2011/65/EU	RoHS directive
2014/30/EU	Electromagnetic Compatibility Directive (EMC)
2014/34/EU	ATEX Directive

6.2 Safety notes

- Observe the safety regulations of electrical engineering and industrial safety and liability associations.
- Disregarding these safety regulations may result in death, serious personal injury or damage to equipment.
- The device must be operated in a closed control cabinet!
- Before working on the device, disconnect the power.
- During operation, parts of electrical switching devices carry hazardous voltages.
- In the event of an error, replace the device.
- Keep the product documentation in a safe place.

6.3 Installation notes

- The device is an item of associated equipment (category 1) with "intrinsic safety" protection and can be installed in Zone 2 potentially explosive areas as a category 3 device. It satisfies the requirements of the following standards. Comprehensive details are to be found in the EU Declaration of Conformity which is enclosed and also available on our website in the latest version:
EN/IEC 60079-0, EN/IEC 60079-11 and EN/IEC 60079-15
- Installation, operation, and maintenance may only be carried out by qualified electricians. Follow the installation instructions as described. When installing and operating the device, the applicable regulations and safety directives (including national safety

directives), as well as general regulations applicable to the technology, must be observed. For the safety data, refer to this document and the certificates (EU examination certificate and other approvals if appropriate).

- The device must not be opened or modified. Do not repair the device yourself, replace it with an equivalent device. Repairs may only be carried out by the manufacturer. The manufacturer is not liable for damage resulting from violation.
- The IP20 protection (IEC 60529/EN 60529) of the device is intended for use in a clean and dry environment. The device must not be subject to mechanical strain and/or thermal loads, which exceed the limits described.
- The 12-pos. S-PORT interface is designed with type of protection "intrinsic safety (Ex ic)". Only devices from Phoenix Contact specified for this type of protection may be connected.
- The device complies with the EMC regulations for industrial areas (EMC class A). When using the device in residential areas, it may cause radio interference.
- The device must be stopped if it is damaged, has been subjected to an impermissible load, stored incorrectly, or if it malfunctions.

6.4 Intrinsic safety

- The device is approved for intrinsically safe (Ex-i) circuits up to Ex zone 0 (gas) and Ex zone 20 (dust). The safety technology values for intrinsically safe equipment and the connecting lines must be observed for the hook-up process (IEC/EC 60079-14) and the values specified in this installation note and/or the EC examination certificate must be observed.
- When carrying out measurements on the intrinsically safe side, observe the relevant regulations regarding the connection of intrinsically safe equipment. Use only these approved measuring devices in intrinsically safe circuits.
- If the device was used in circuits which are not intrinsically safe, it is forbidden to use it again in intrinsically safe circuits. Label the device clearly as being not intrinsically safe.

6.5 Installation in Zone 2

- Observe the specified conditions for use in potentially explosive areas! Install the device in a suitable, approved housing that meets the requirements of IEC/EN 60079-15 and has at least IP54 protection. Also observe the requirements of IEC/EN 60079-14.
- Only devices which are designed for operation in Ex zone 2 and are suitable for the conditions at the installation location may be connected to the circuits in the Ex zone.
- In zone 2 only connect or disconnect cables and adjust the DIP switch when the power is disconnected.
- The device must be stopped and immediately removed from the Ex area if it is damaged, was subject to an impermissible load, stored incorrectly or if it malfunctions.
- Temporary malfunctions (transients) must not exceed the value of 497 V (355 V x 1.4).

6.6 Potentially dust-explosive areas

- The device is not suitable for installation in zone 22.
- If you nevertheless intend to use the device in zone 22, you must install it in a housing according to IEC/EN 60079-31. Observe the maximum surface temperatures in this case. Adhere to the requirements of IEC/EN 60079-14.
- Connection to the intrinsically safe circuit in areas with a danger of dust explosions (zone 20, 21 or 22) is only permitted if the equipment connected to this circuit is approved for this zone (e.g., category 1D, 2D or 3D).

6.7 Safety-related applications (SIL, PL)

When using the device in safety-related applications, observe the instructions in "Safety-related applications", as the requirements differ for safety-related functions.



The switching output is not intended for safety-related applications.



WARNING: Danger of death!

It is possible to set SIL ON or SIL OFF in the configuration tools. Applications according to the Machinery directive (EN ISO 13849-1) only permit the SIL ON mode. Another mode means danger of death and is not permitted.

6.8 UL note

The safety specifications, which are based on UL approval, can be found in the "Control Drawing". The "Control Drawing" is part of the package slip.

7 Minimum spans and measuring accuracy

7.1 Input for Pt RTDs and Ni RTDs

Minimum measuring span:

For $10 \Omega \leq R_0 < 100 \Omega$: 100 K

For $100 \Omega \leq R_0 \leq 10 \text{ k}\Omega$: 20 K

R_0 is the resistance value of the sensor at 0°C.

Measuring accuracy:

For $10 \Omega \leq R_0 < 100 \Omega$: **0.2 K x 100 Ω / R_0**

= 0.1% x (100 Ω / R_0) x (200 K / measuring span)

For $100 \Omega \leq R_0 \leq 1 \text{ k}\Omega$: **0.2 K**

= 0.1% x (200 K / measuring span)

For $1 \text{ k}\Omega < R_0 \leq 10 \text{ k}\Omega$: **0.4 K**

= 0.1% x (400 K / measuring span)

7.2 Input for Cu RTDs

Minimum measuring span:

For $10 \Omega \leq R_0 < 100 \Omega$: 100 K

For $100 \Omega \leq R_0 \leq 10 \text{ k}\Omega$: 20 K

Measuring accuracy:

For $10 \Omega \leq R_0 < 100 \Omega$: **0.5 K x 100 Ω / R_0**

= 0.1% x (100 Ω / R_0) x (500 K / measuring span)

For $100 \Omega \leq R_0 \leq 1 \text{ k}\Omega$: **0.5 K**

= 0.1% x (500 K / measuring span)

For $1 \text{ k}\Omega < R_0 \leq 10 \text{ k}\Omega$: **1.0 K**

= 0.1% x (1000 K / measuring span)

7.3 Input for Ni 1000 (Landis & Gyr), KTY 81-110, KTY 84-130 (Philips)

Minimum measuring span: 20 K

Measuring accuracy: 0.2 K

7.4 Input for thermocouples

Minimum measuring span with TC: 50 K

Measuring accuracy of the input with TC signals:

TC type E, J, K, N, T, L, U, M, Lr

Without cold junction error: 0.30 K

TC type B, R, S, C, D, A1, A2, A3

Without cold junction error: 0.50 K

7.5 Cold junction error

Cold junction error: ± 1 K, maximum

(for internal cold junction compensation)

For external compensation it depends on the quality of the cold junction and the sensor used.

7.6 Input for voltage signals

Minimum measuring span:

10% of the nominal span of the respective range.

Measuring accuracy:

-1000 ... 1000 mV : 0.01% (of the measuring range)

-500 ... 500 mV : 0.01% (of the measuring range)

-250 ... 250 mV : 0.01% (of the measuring range)

-125 ... 125 mV : 0.01% (of the measuring range)

-60 ... 60 mV : 0.01% (of the measuring range)

-30 ... 30 mV : 0.01% (of the measuring range)

-15 ... 15 mV : 0.01% (of the measuring range)

7.7 Resistance-type sensors and resistors

50% of measuring range \leq (nominal value of resistance-type sensor + lead resistance) \leq measuring range

Minimum measuring span: 10% of the selected measuring range

Measuring accuracy:

0 ... 75 Ω : 0.10% (of the measuring range)

0 ... 150 Ω : 0.05% (of the measuring range)

0 ... 300 Ω : 0.02% (of the measuring range)

0 ... 600 Ω : 0.01% (of the measuring range)

0 ... 1200 Ω : 0.01% (of the measuring range)

0 ... 2400 Ω : 0.01% (of the measuring range)

0 ... 4800 Ω : 0.01% (of the measuring range)

0 ... 6250 Ω : 0.02% (of the measuring range)

0 ... 12500 Ω : 0.02% (of the measuring range)

0 ... 25000 Ω : 0.02% (of the measuring range)

0 ... 50000 Ω : 0.02% (of the measuring range)

Example:

Resistance-type sensor with nominal value: 1000 Ω

Measuring range to be selected: 0 ... 1200 Ω

Minimum measuring span: 10% of the selected measuring range = 120 Ω

Measuring accuracy: 0.01% of the selected measuring range = 120 m Ω

7.8 Potentiometer

50% of measuring range \leq (nominal value of potentiometer + lead resistance) \leq measuring range

Minimum measuring span: 10% of the selected measuring range

Measuring accuracy:

0 ...	75 Ω	: 0.10%	(of the measuring range)
0 ...	150 Ω	: 0.05%	(of the measuring range)
0 ...	300 Ω	: 0.02%	(of the measuring range)
0 ...	600 Ω	: 0.02%	(of the measuring range)
0 ...	1200 Ω	: 0.02%	(of the measuring range)
0 ...	2400 Ω	: 0.02%	(of the measuring range)
0 ...	4800 Ω	: 0.02%	(of the measuring range)
0 ...	6250 Ω	: 0.10%	(of the measuring range)
0 ...	12500 Ω	: 0.10%	(of the measuring range)
0 ...	25000 Ω	: 0.10%	(of the measuring range)
0 ...	50000 Ω	: 0.10%	(of the measuring range)

Example:

Potentiometer with nominal value: 1000 Ω

Measuring range to be selected: 0 ... 1200 Ω

Minimum measuring span: 10% of the selected measuring range = 120 Ω

Measuring accuracy: 0.02% of the selected measuring range = 240 m Ω

7.9 Output signals

Error at analog output:

2 mV	0.01% at -10 ... 10 V
2 mV	0.02% at 0 ... 10 V
4 μ A	0.02% at 0 ... 20 mA

8 Installation



NOTE: Electrostatic discharge

The device contains components that can be damaged or destroyed by electrostatic discharge. When handling the device, observe the necessary safety precautions against electrostatic discharge (ESD) according to EN 61340-5-1 and EN 61340-5-2.

Take protective measures against electrostatic discharge before opening the front cover.

8.1 Basic circuit diagrams

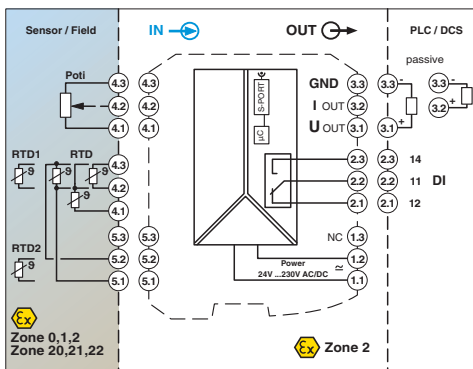

Figure 1 Sensor connection - resistance temperature detectors and potentiometers

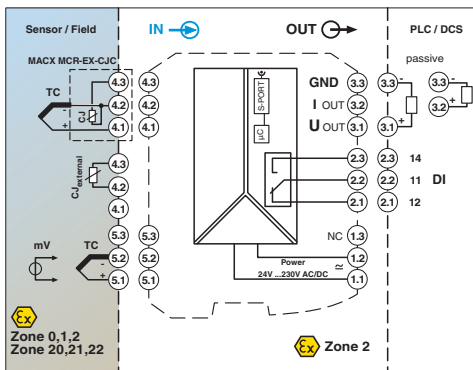

Figure 2 Sensor connection - thermocouples and mV sources

8.2 Structure

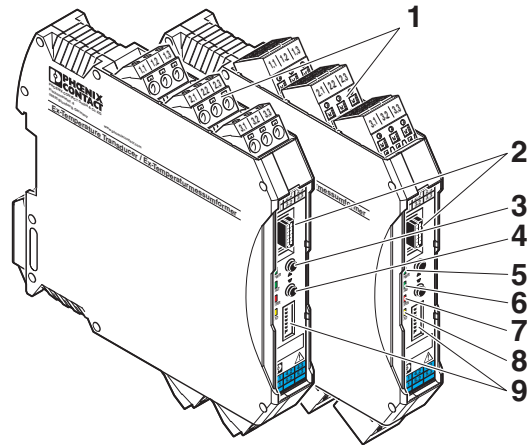

Figure 3 MACX MCR-EX-T-UI-UP(-SP) structure

- 1 COMBICON plug-in, screw, or push-in spring connection terminal
- 2 S-PORT (12-pos. programming interface)
- 3 Button S3 (UP), adjustment and reset functions
- 4 Button S2 (DOWN), adjustment and reset functions
- 5 PWR LED, green, power supply
- 6 DAT LED, green, no function at present
- 7 ERR LED, red
on: module error
1.2 Hz flashing: service mode
2.4 Hz flashing: line error
- 8 DO LED, yellow, status of switching output

8.3 Dimensions

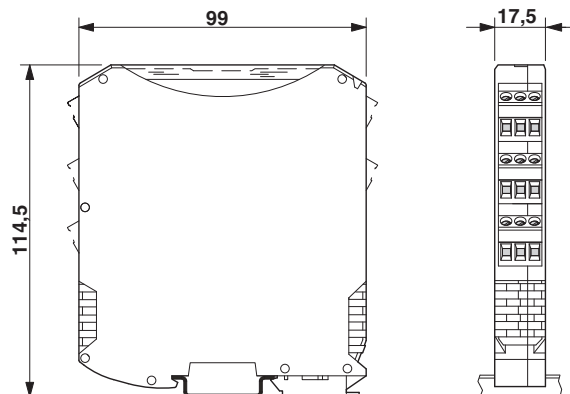

Figure 4 Dimensions (in mm)

8.4 Mounting



WARNING: Explosion hazard

If the module has been used in non-intrinsically safe circuits, it must not be used again in intrinsically safe circuits.

The module must be clearly marked as non-intrinsically safe.

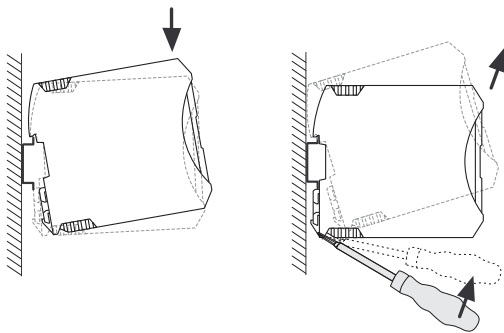

Figure 5 Mounting and removal

- Mount the module on a 35 mm DIN rail according to EN 60715.
- Install the module in suitable housing to meet the requirements for the protection class.
- Before startup, check that the MACX MCR-EX-T-UI-UP... is operating and wired correctly, especially with regard to the wiring and marking of the intrinsically safe circuits.

8.5 Connection of the cables

- Screw terminal blocks (for MACX MCR-EX-T-UI-UP); fit the litz wires with ferrules.
Permissible cable cross-section: 0.2 mm² to 2.5 mm²
- Spring-cage terminal blocks (for MACX MCR-EX-T-UI-UP-SP); fit the litz wires with ferrules.
Permissible cable cross-section: 0.2 mm² to 1.5 mm²
- Install intrinsically safe and non-intrinsically safe cables separately.
- **Screw connection:**
 - Insert the conductor into the corresponding connection terminal block.
 - Use a screwdriver to tighten the screw in the opening above the connection terminal block.
- **Spring-cage connection:**
 - Insert a screwdriver into the opening above the connection terminal block.

- Insert the conductor into the corresponding connection terminal block.

8.6 Power supply

The power supply has been designed as a wide range power supply (19.2 ... 253 V AC/DC). The module is supplied with voltage via connection terminal blocks 1.1 and 1.2.

8.7 Sensor types

The sensor types that can be used and their specific properties can be found in Section "Order key" on page 9

Depending on the connection technology, the following terminal points are to be connected for temperature measurement (see Figure 1 on page 17).

8.7.1 Thermocouple (TC) with internal cold junction compensation

- Thermocouple connection: terminals 4.1 "+", 4.2 "-"



Use the MACX MCR-EX-CJC cold junction compensation connector provided (Order No. 2925002).



TC + CJ: use the cold junction compensation connector provided at connection terminal blocks 4.1, 4.2, and 4.3.

8.7.2 Thermocouple (TC) with external or without cold junction compensation

- Thermocouple connection: terminals 5.1 "+", 5.2 "-"



TC + CJ external: use the external cold junction sensor (e.g., Pt 100) at connection terminal blocks 4.2 and 4.3.

8.7.3 Voltage input

- Connection: terminals 5.1 "+", 5.2 "-"

8.7.4 Potentiometer

- Connection: terminals 4.1, 4.2, 4.3

8.7.5 Resistance temperature detector (RTD)



$RL \leq 25 \Omega$ for each lead.

- 2-wire connection technology: terminals 4.2, 4.3
The cable resistance can be compensated with the help of the IFS-CONF PC program, the IFS-OP-UNIT operator interface or in service mode (DIP switch).
- 3-wire connection technology: terminals 4.1, 4.2, 4.3
In the case of 3-wire connection technology, ensure that all three cables have the same resistance.
- 4-wire connection technology: terminals 4.2, 4.3, 5.1, 5.2
- 2 x 2-wire connection technology
RTD 1 terminals: 4.2, 4.3
RTD 2 terminals: 5.1, 5.2

8.7.6 Resistance measurement



Up to 75 Ω : $RL \leq 2.5 \Omega$ for each lead.
Up to 150 Ω : $RL \leq 5 \Omega$ for each lead.
Up to 300 Ω : $RL \leq 10 \Omega$ for each lead.

Terminal points 4.2 and 4.3 are used for measuring differing resistances.

8.8 Notes on using thermocouples

Thermocouples consist of two conductors connected to each other on one side. The conductors consisting of different metals with different thermoelectric properties are exposed to a temperature gradient and, therefore, will convert heat flow to electrical voltage. Electrical voltage is measured at both thermocouple connections.

8.8.1 Cold junction compensation

In a thermocouple, however, voltage will not only be generated at the contact point of the connected conductors, but also at both connection points of the measuring transducer, as each of these points together with the connected thermocouple cable will form another thermocouple.

In order to be able to calculate the absolute measurement point temperature value from this voltage difference, and thus also the temperature difference, the temperature of the connection points must be the same and known.

For this purpose, the connection points are artificially maintained at a known temperature: for laboratory measurements, for example, at 0°C using ice water, in industrial applications by thermostatically controlled heating and cooling.

When considering the connection point temperature, this is referred to as cold junction compensation.

Cold junction compensation can also be implemented with a separate temperature measurement at the connection points.

Interface modules are available for the connection of thermocouples, in which cold junction compensation is already integrated. Interface modules of this type are also signal transformers with cable connections to the evaluation unit.

Thermocouples are often referred to with the abbreviation TC.



Thermocouples are suitable for high temperatures or large temperature ranges.
Resistance temperature detectors are more suitable for temperatures up to a maximum of 800°C.

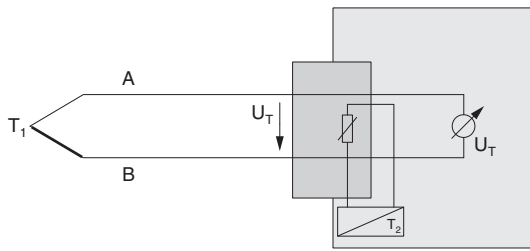

Figure 6 Thermocouple and interface module at the sensor including cold junction compensation

- T_1 Temperature at the measurement point
 T_2 Temperature at the connection point
 U_T Voltage generated between the measurement point and the connection point. Indicates the absolute temperature T_1 at the measurement point by considering the connection point temperature T_2 .

8.8.2 Thermocouple types

Type	Standard	Temperature range [°C]	IEC color code
B	IEC 584	+500 ... +1820	Not defined
E	IEC 584	-230 ... +1000	Purple
J	IEC 584	-210 ... +1200	Black
K	IEC 584	-250 ... +1372	Green
N	IEC 584	-200 ... +1300	Pink
R	IEC 584	-50 ... +1768	Orange
S	IEC 584	-50 ... +1768	Not defined
T	IEC 584	-200 ... +400	Brown
L	DIN 43710	-200 ... +900	-
U	DIN 43710	-200 ... +600	-
A-1	GOST 8.585	0 ... +2500	-
A-2	GOST 8.585	0 ... +1800	-
A-3	GOST 8.585	0 ... +1800	-
M	GOST 8.585	-200 ... +100	-
L	GOST 8.585	-200 ... +800	-

8.9 Current output

The current output can be freely configured between 0 ... 20 mA. The minimum span is 4 mA. In safety-related applications (SIL = ON), the output is fixed at 4 ... 20 mA.

- Connection: terminals 3.2 "+", 3.3 "-"



Insert a wire jumper at the terminals of the current output (terminals 3.2 and 3.3) when not using the current output. Otherwise, the module will detect an open circuit and switch to the safe state (relays drop out).

8.10 Voltage output



The voltage output cannot be used for safety-related applications (SIL = ON).

The voltage output can be freely configured between -10 ... +10 V. The minimum span is 2 V.

- Connection: terminals 3.2 "+", 3.3 "-"

8.11 Switching output

Switching output 1 has one changeover contact. The behavior of the switching output can be selected. Switching points SPL¹ and SPH² can be configured across the entire sensor range:

Switching behavior of the switching output

Switching behavior 0



Switching output is permanently dropped.

Switching behavior 1

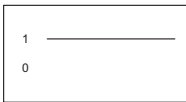

Switching output is permanently picked up.

Switching behavior 2

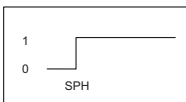

Switching output picks up when SPH² is exceeded.

Switching behavior 3

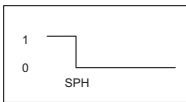

Switching output drops out when SPH² is underrange.

Switching behavior 4

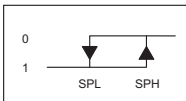

Switching output picks up when SPL² is exceeded and drops out when SPH¹ is underrange (hysteresis).

Switching behavior 5

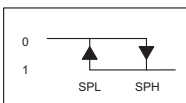

Switching output drops out when SPL² is exceeded and picks up when SPH¹ is underrange (hysteresis).

Switching behavior 6

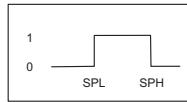

Switching output picks up between SPL¹ and SPH².

Switching behavior 7

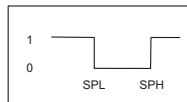

Switching output drops out between SPL¹ and SPH².

¹ SPL = Set Point Low (lower switching point)

² SPH = Set Point High (upper switching point)



The switching output is not intended for safety-related applications.



If only the switching output is to be used, the current output (connection terminals 3.2 and 3.3) must be short circuited or subjected to a load. Otherwise, the device switches to the safe state if line fault detection is activated.

8.12 Switching output behavior with manual acknowledgement (latching)



Latching: no automatic restart after exceeding the limit value (SPH: Set Point High) or falling below the limit value (SPL: Set Point Low).
Disable the "Restart after fail safe" option in the configuration software.

8.12.1 Switching behavior (2): undertemperature limit (\leq SPH)

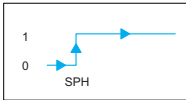

Normal operating state $>$ SPH

Step	Measure
1	Measured value $>$ SPH, and module is activated
2	Relay ON
3	Measured value \leq SPH
4	Relay OFF
5	Measured value $>$ SPH
6	Relay Remains OFF (latches) until delay time has elapsed and is then acknowledged manually

Acknowledgement is only possible if there is no critical state anymore and the delay time has elapsed.

Critical operating state \leq SPH

Step	Measure
1	Measured value \leq SPH, and module is activated
2	Relay OFF
3	Measured value $>$ SPH
4	Relay Remains OFF (latches) until delay time has elapsed and is then acknowledged manually

Acknowledgement is only possible if there is no critical state anymore and the delay time has elapsed.

8.12.2 Switching behavior (3): overtemperature limit (\geq SPH)

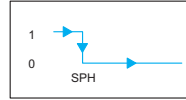

Normal operating state $<$ SPH

Step	Measure
1	Measured value $<$ SPH, and module is activated
2	Relay ON
3	Measured value \geq SPH
4	Relay OFF
5	Measured value $<$ SPH
6	Relay Remains OFF (latches) until delay time has elapsed and is then acknowledged manually

Acknowledgement is only possible if there is no critical state anymore and the delay time has elapsed.

Critical operating state \geq SPH

Step	Measure
1	Measured value \geq SPH, and module is activated
2	Relay OFF
3	Measured value $<$ SPH
4	Relay Remains OFF (latches) until delay time has elapsed and is then acknowledged manually

Acknowledgement is only possible if there is no critical state anymore and the delay time has elapsed.

8.12.3 Switching behavior (4): undertemperature limit with hysteresis (\leq SPL)

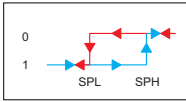

Normal operating state $>$ SPL

Step	Measure
1	Measured value $>$ SPL, and module is activated
2	Relay ON
3	Measured value \leq SPL
4	Relay OFF
5	Measured value $>$ SPH
6	Relay Remains OFF (latches) until delay time has elapsed and is then acknowledged manually

Acknowledgement is only possible if there is no critical state anymore and the delay time has elapsed.

8.12.4 Switching behavior (5): overtemperature limit with hysteresis (\geq SPH)

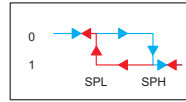

Normal operating state $<$ SPH

Step	Measure
1	Measured value $<$ SPH, and module is activated
2	Relay ON
3	Measured value \geq SPH
4	Relay OFF
5	Measured value $<$ SPL
6	Relay Remains OFF (latches) until delay time has elapsed and is then acknowledged manually

Acknowledgement is only possible if there is no critical state anymore and the delay time has elapsed.

Critical operating state \leq SPL

Step	Measure
1	Measured value \leq SPL, and module is activated
2	Relay OFF
3	Measured value $>$ SPH
4	Relay Remains OFF (latches) until delay time has elapsed and is then acknowledged manually

Acknowledgement is only possible if there is no critical state anymore and the delay time has elapsed.

Critical operating state \geq SPH

Step	Measure
1	Measured value \geq SPH, and module is activated
2	Relay OFF
3	Measured value $<$ SPL
4	Relay Remains OFF (latches) until delay time has elapsed and is then acknowledged manually

Acknowledgement is only possible if there is no critical state anymore and the delay time has elapsed.

8.12.5 Switching behavior (6): temperature range limit (\leq SPL and \geq SPH)

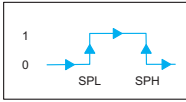

Normal operating state $>$ SPL and $<$ SPH

Step	Measure
1	Measured value $>$ SPL and $<$ SPH, module is activated
2	Relay ON
3	Measured value \leq SPL or \geq SPH
4	Relay OFF
5	Measured value $>$ SPL or $<$ SPH
6	Relay Remains OFF (latches) until delay time has elapsed and is then acknowledged manually

Acknowledgement is only possible if there is no critical state anymore and the delay time has elapsed.

Critical operating state \leq SPL and \geq SPH

1	Measured value a) \leq SPL, and module is activated b) \geq SPH, and module is activated
2	Relay OFF
3	Measured value a) $>$ SPL and $<$ SPH b) $<$ SPH and $>$ SPL
4	Relay Remains OFF (latches) until delay time has elapsed and is then acknowledged manually

Acknowledgement is only possible if there is no critical state anymore and the delay time has elapsed.

8.12.6 Switching behavior (7): temperature range limit (\geq SPL and \leq SPH)

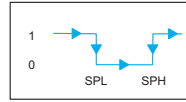

Normal operating state $<$ SPL and $>$ SPH

Step	Measure
1	Measured value a) $<$ SPL, and module is activated b) $>$ SPH, and module is activated
2	Relay ON
3	Measured value a) \geq SPL and \leq SPH b) \leq SPH and \geq SPL
4	Relay OFF
5	Measured value $<$ SPL or $>$ SPH
6	Relay Remains OFF (latches) until delay time has elapsed and is then acknowledged manually

Acknowledgement is only possible if there is no critical state anymore and the delay time has elapsed.

Critical operating state \geq SPL and \leq SPH

Step	Measure
1	Measured value \geq SPL and \leq SPH, and module is activated
2	Relay OFF
3	Measured value $<$ SPL or $>$ SPH
4	Relay Remains OFF (latches) until delay time has elapsed and is then acknowledged manually

Acknowledgement is only possible if there is no critical state anymore and the delay time has elapsed.

8.13 Monitoring function

The temperature transducer is equipped with monitoring functions for the input and output range.

Input monitoring function

The input monitoring function for line break and short circuit refers to the sensor connected to the input. When an error is detected, the output signal is set to the configured error value. In the case of RTD sensors and resistance-type sensors, short-circuit failures are detected resistance values $<1 \Omega$.

Short circuits of thermocouples and mV sources cannot be detected, since 0 V can be a valid signal. Short circuits can be detected in the event of underrange, provided that a life-zero signal is configured.

On RTD sensors, resistance-type sensors and potentiometers, a line break is detected when the current flow through the sensor is faulty.

When using the mV input, a line break is not detected. When connecting a resistance (10 k Ω / 0.6 W or similar) between input terminals 5.1 and 5.2, line break can be detected in the event of underrange.

As soon as the fault has been eliminated, the temperature transducer continues to perform its normal functions. (See "LED status indicators" on page 28, Line fault)

Output monitoring function

The current output can be monitored for line breaks and maximum load. This is activated via the configuration. In safety-related applications (SIL = ON), output monitoring is always active. The voltage output is not monitored. As soon as the fault has been eliminated, the temperature transducer continues to perform its normal functions. (See "LED status indicators" on page 28, Line fault)

8.14 Operating modes



If the configuration is modified using the IFS-OP-UNIT operator interface and PC-based software (e.g., IFS-CONF) or via the DIP switch, the changes made must always be checked again and released before transfer to the temperature transducer.

After the transfer, the new data in the temperature transducer is applied by means of activation and a warm start.

8.14.1 SIL ON / SIL OFF

The temperature transducer can either be operated in normal SIL ON or SIL OFF mode. The standard configuration is SIL ON with DIP switch S1 set to the OFF position. With the order configuration, customer-specific configurations can be selected in the order key (see "Order key" on page 9).

8.14.2 Service mode

Service mode can be selected at any time via the IFS-OP-UNIT operator interface and the configuration software, e.g., IFS-CONF or via DIP switch S1.

If settings are changed during service mode and service mode is then exited, the temperature transducer performs a warm start in order to apply the newly set values. If no changes are made, the transducer starts up in normal measuring mode without a warm start. The switching output switches according to its configuration.

In service mode, it is also possible to simulate the output signal independently of the input signal (force). In this case, in safety-related applications, the safety function of the device is deactivated and the initial value for the analog output signal is 2 mA, which allows subsequent devices to detect the deviation from normal mode as a result of the measured value being underrange.

During service mode, the switching output is deactivated and remains in its idle position.

9 Configuration



WARNING: Explosion hazard

If configuring for zone 2, the PC must be approved for use in zone 2.

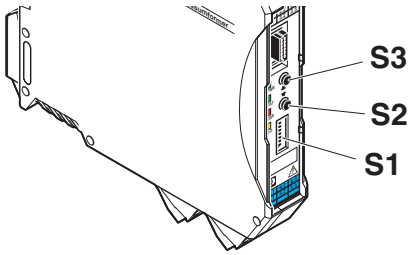

Figure 7 Position of the DIP switch and buttons



When one of the S1-2 ... S1-8 DIP switches is switched on (ON), the device is switched to service mode. The red ERR LED flashes (1.2 Hz) and a diagnostic peripheral fault is displayed on the start screen.

9.1 Delivery state / standard configuration

Switch position, DIP S1							
1	2	3	4	5	6	7	8
OFF	OFF	OFF	OFF	OFF	OFF	OFF	OFF

9.2 Zero adjust, adjustment via DIP switch S2 and S3 (only possible with SIL OFF)

- Set the adjustment by setting DIP switch S1-2 to ON.
- Observe the analog output and set with the S2 (descending value) or S3 (ascending value) button.
Or
Pressing buttons S2 and S3 simultaneously for >3 seconds resets the cable compensation.
- Save the set value by setting DIP switch S1-2 back to OFF.

Switch position, DIP S1							
1	2	3	4	5	6	7	8
OFF	ON	OFF	OFF	OFF	OFF	OFF	OFF

9.3 Span adjust, adjustment via DIP switch 2 and 3 (only possible with SIL OFF)

- Set the adjustment by setting DIP switch S1-3 to ON.
- Observe the analog output and set with the S2 (descending value) or S3 (ascending value) button.
Or
Pressing buttons S2 and S3 simultaneously for >3 seconds resets the cable compensation.
- Save the set value by setting DIP switch S1-3 back to OFF.
- Pressing buttons S2 and S3 simultaneously for >3 seconds resets the adjustment.

Switch position, DIP S1							
1	2	3	4	5	6	7	8
OFF	OFF	ON	OFF	OFF	OFF	OFF	OFF

9.4 Force output



When SIL is activated, the analog output starts at 2 mA and the switching output is deactivated.

- Set the adjustment by setting DIP switch S1-4 to ON.
- Observe the analog output and set with the S2 (descending value) or S3 (ascending value) button.
- The specification/simulation is reset and ended by setting DIP switch S1-4 back to OFF.

Switch position, DIP S1							
1	2	3	4	5	6	7	8
OFF	OFF	OFF	ON	OFF	OFF	OFF	OFF

9.5 Cable compensation, 2-wire RTD or RTD 1 with 2 x RTD

- Set the RTD 1 cable compensation via DIP switches S1-1 to OFF and S1-5 to ON.
- Short circuit the sensor.
- Apply the current measured value as the cable resistance by pressing the S2 button.
- Save the set value by setting DIP switch S1-5 back to OFF.

Pressing buttons S2 and S3 simultaneously for >3 seconds resets the cable compensation.

Switch position, DIP S1							
1	2	3	4	5	6	7	8
OFF	OFF	OFF	OFF	ON	OFF	OFF	OFF

9.6 Cable compensation RTD 2 with 2 x RTD or TC with external cold junction compensation (TC + CJ external)

- Set the RTD 2 cable compensation via DIP switches S1-1 to ON and S1-5 to ON.
- Short circuit the sensor.
- Apply the current measured value as the cable resistance by pressing the S2 button.
- Save the set value by setting DIP switches S1-1 and S1-5 back to OFF.

Pressing buttons S2 and S3 simultaneously for >3 seconds resets the cable compensation.

Switch position, DIP S1							
1	2	3	4	5	6	7	8
ON	OFF	OFF	OFF	ON	OFF	OFF	OFF

9.7 Automatic potentiometer adjustment (teach-in)

- Set the teach-in function by setting DIP switch S1-6 to ON.
- Set the potentiometer to the start of range.
- Press the S2 button.
- Set the potentiometer to the end of range.
- Press the S3 button.
- Save the new measuring range by setting DIP switch S1-6 back to OFF.

Pressing buttons S2 and S3 simultaneously for >3 seconds resets both values.

Switch position, DIP S1							
1	2	3	4	5	6	7	8
OFF	OFF	OFF	OFF	OFF	ON	OFF	OFF

9.8 Manual acknowledgement of switching outputs (latch function)

- Set manual acknowledgment by setting DIP switch S1-7 to ON.
- Press buttons S2 and S3 simultaneously for >3 seconds.
- Reset DIP switch S1-7 to OFF.

Switch position, DIP S1							
1	2	3	4	5	6	7	8
OFF	OFF	OFF	OFF	OFF	OFF	ON	OFF

9.9 LED status indicators

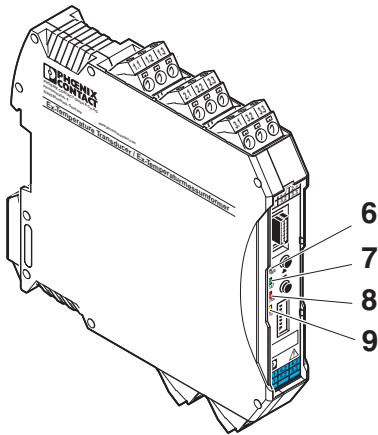

Figure 8 LED status indicators

No.	LED	Color	Description
6	PWR	Green	Supply voltage
		On	Indicates ready-to-operate state of the temperature transducer if supply voltage is available. The temperature transducer is configured without device supply via the IFS-USB-PROG-ADAPTER programming adapter.
7	DAT	Green	No function at present
8	ERR	Red	Error
		On	Module error
		Flashing (1.2 Hz)	Service mode active
9	DO	Flashing (2.4 Hz)	Line fault
		Yellow	Switching output 1
		On	Switching output active

10 Password

The device is protected by means of a four-digit password set in the factory in order to prevent impermissible changes to the configuration.

Default setting: 1111



For safety-related applications, the password set in the factory must always be changed. If the password is lost, a reset is not possible. In this case, please contact Phoenix Contact.

If, however, only data from the device is to be displayed or the device is to be used in non-safety-related applications, the password can be deactivated.

Setting: 0000

The device can be accessed either via the IFS-OP-UNIT (Order No. 2811899) or via a service PC with connected IFS-USB-PROG-ADAPTER programming adapter (Order No. 2811271) and the IFS-CONF configuration software.



Further information on configuration with the IFS-OP-UNIT or the IFS-CONF configuration software can be found in the relevant user manual.



WARNING: If *Functional Safety* is activated by a reconfiguration or changes are made to the active *Functional Safety* configuration, the rules in the appendix under "Installation and startup" must be observed.



WARNING: Limitations for safety-related applications

4 ... 20 mA only, limited programming of output current in the event of line faults ($2 \text{ mA} \leq I_{\text{Out}} \leq 3.6 \text{ mA}$ or $I_{\text{Out}} \geq 21 \text{ mA}$)



WARNING: Once new configuration data has been written, the device performs a warm start that changes the properties of the device. The following control device must be adapted to these modifications.



NOTE: Transfer and activate the configuration after the password has been changed.

11 Configuration with the service PC

When making changes to the configuration data, use the IFS-CONF software (free download: phoenixcontact.net/products).



Information on configuration, parameterization, and service options (e.g., online monitoring) and their execution can be found in the online help of the software and in the associated user manuals of the DTMs (Device Type Manager).

- Connect the device and PC with the help of the IFS-USB-PROG-ADAPTER programming adapter (Order No. 2811271).

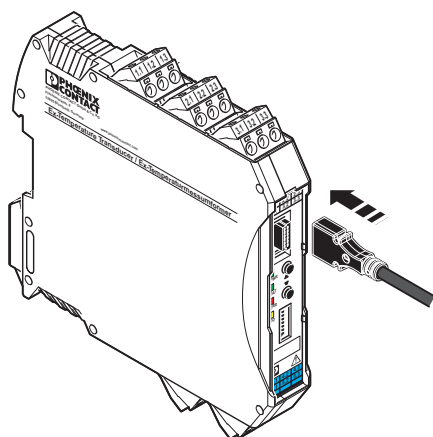

Figure 9 IFS-USB-PROG-ADAPTER

Changes to the configuration and parameterization data can be made during operation with a connected Ex measuring circuit as well as in a disconnected state.

11.1 System requirements

- PC or compatible computer with 400 MHz or higher with at least 256 Mbyte RAM
- At least 15 Mbyte available hard disk space
- Free USB interface, at least USB 1.1
- Screen resolution of 1024 x 768 pixels
- Windows 2000 SP4, Windows XP SP2, Windows 7, Windows 8, Win 10



The drivers for the IFS-USB-PROG-ADAPTER USB programming adapter are installed automatically.

11.2 Configuring the user characteristic curve



Freely configurable user characteristic curve for individual adaptation of resistance temperature detectors (RTD) and thermocouples (TC).

The user characteristic curve is created with the PC-based IFS-CONF software and stored in the temperature transducer.



The user characteristic curve is either selected with the IFS-CONF or with the IFS-OP-UNIT software.

12 Comparison of the safety data



WARNING: Explosion hazard

Compare the safety data before connecting a device located in the intrinsically safe area to the MACX MCR-EX-T-UI-UP...

Safety-related data of

Field devices: U_i, I_i, P_i, L_i, C_i
 Temperature transducers: U_o, I_o, P_o, L_o, C_o

The values for U_o, I_o, P_o, L_o and C_o can be found under "Safety data as per ATEX" on page 11.

Requirements for intrinsic safety (simple circuits):

$$U_i \geq U_o$$

$$I_i \geq I_o$$

$$P_i \geq P_o$$

$$L_i + L_c \leq L_o$$

$$C_i + C_c \leq C_o$$

(L_c and C_c depend on the cables/lines used).

13 Application examples

13.1 Current output

Connection example 1:

Input: 4-wire RTD
 Output: Current output (4 ... 20 mA) on passive safe controller

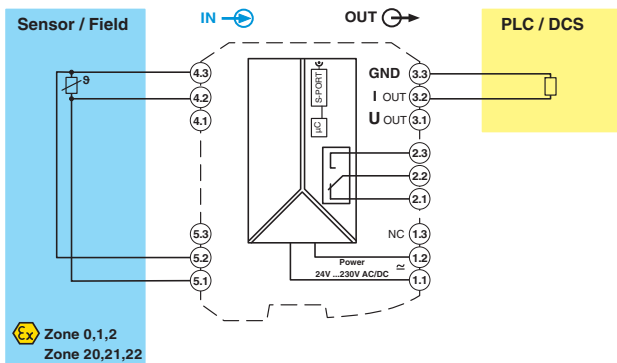

Connection example 3:

Input: Thermocouple with external or without cold junction compensation or voltage input
 Output: Current output (4 ... 20 mA) on passive safe controller

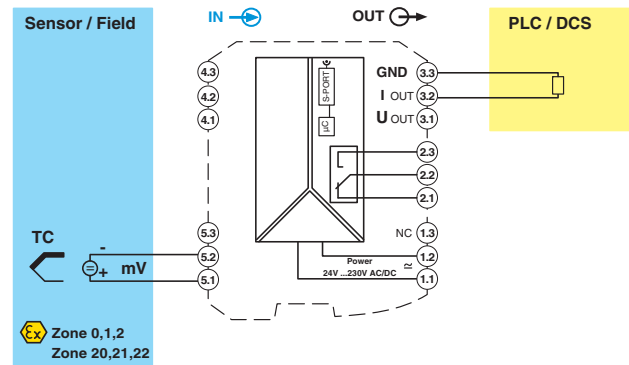

i When using the mV input in applications up to SIL 2, only a limited scope of functions is available (see Appendix 1 "Safety-related applications (SIL 2)", Section 1.6 "Functional restrictions").

Connection example 2:

Input: Thermocouple with internal cold junction compensation



Use the MACX MCR-EX-CJC cold junction compensation plug provided (Order No. 2925002).

Output: Current output (4 ... 20 mA) on passive safe controller

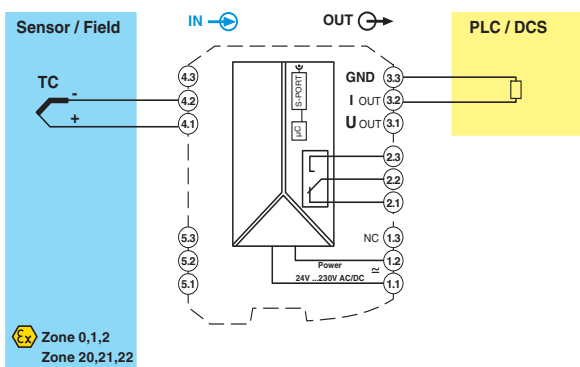

13.2 Voltage output

Connection example:

Input: Potentiometer
 Output: Voltage output (-10 ... 10 V) on passive controller

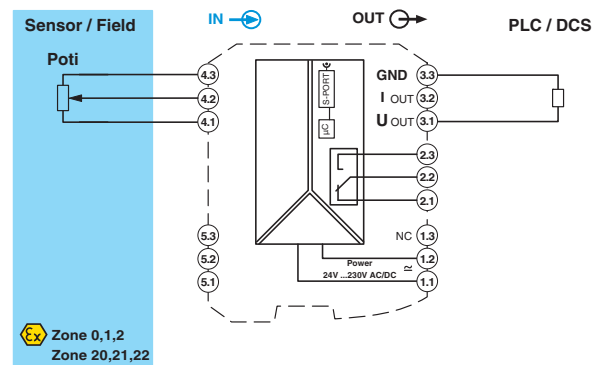

13.3 Switching output

Connection example:

- Input: 3-wire RTD
- Output: Voltage output (-10 ... 10 V) on passive controller
- Switching output: Dependent on selected switching behavior

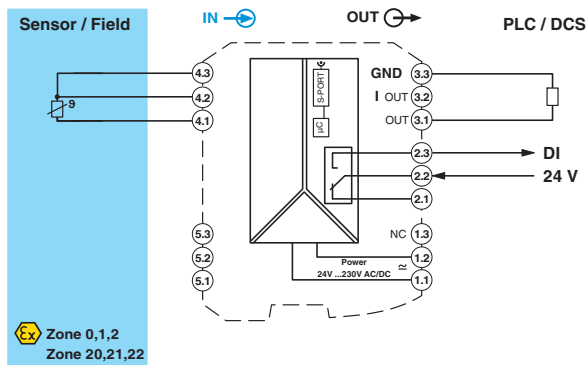

14 Flow chart, operator interface

Configuration with the IFS-OP-UNIT

If you wish to use the MACX MCR-EX-T-UI-UP in combination with the IFS-OP-UNIT and with the IFS-OP-CRADLE, the various operating functions that can be selected are shown on the display.

i When active, the SIL functionality is displayed on the start screen.

Example: display view for SIL ON

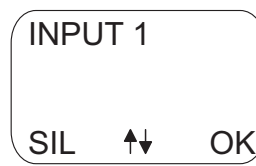

Example: display view for SIL OFF

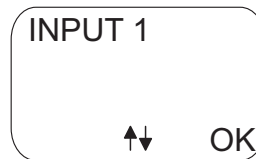

i For safety reasons, the SIL function cannot be switched on again via the IFS-OP-UNIT operator interface.

i SIL can be switched off/deactivated via the SIL OFF menu item.
To reactivate/switch on the SIL function, PC-based configuration software, e.g., IFS-CONF, is required.

i If no input is entered for five minutes during configuration, the configuration is ended and any unsaved data will be lost.

14.1 Menu structure

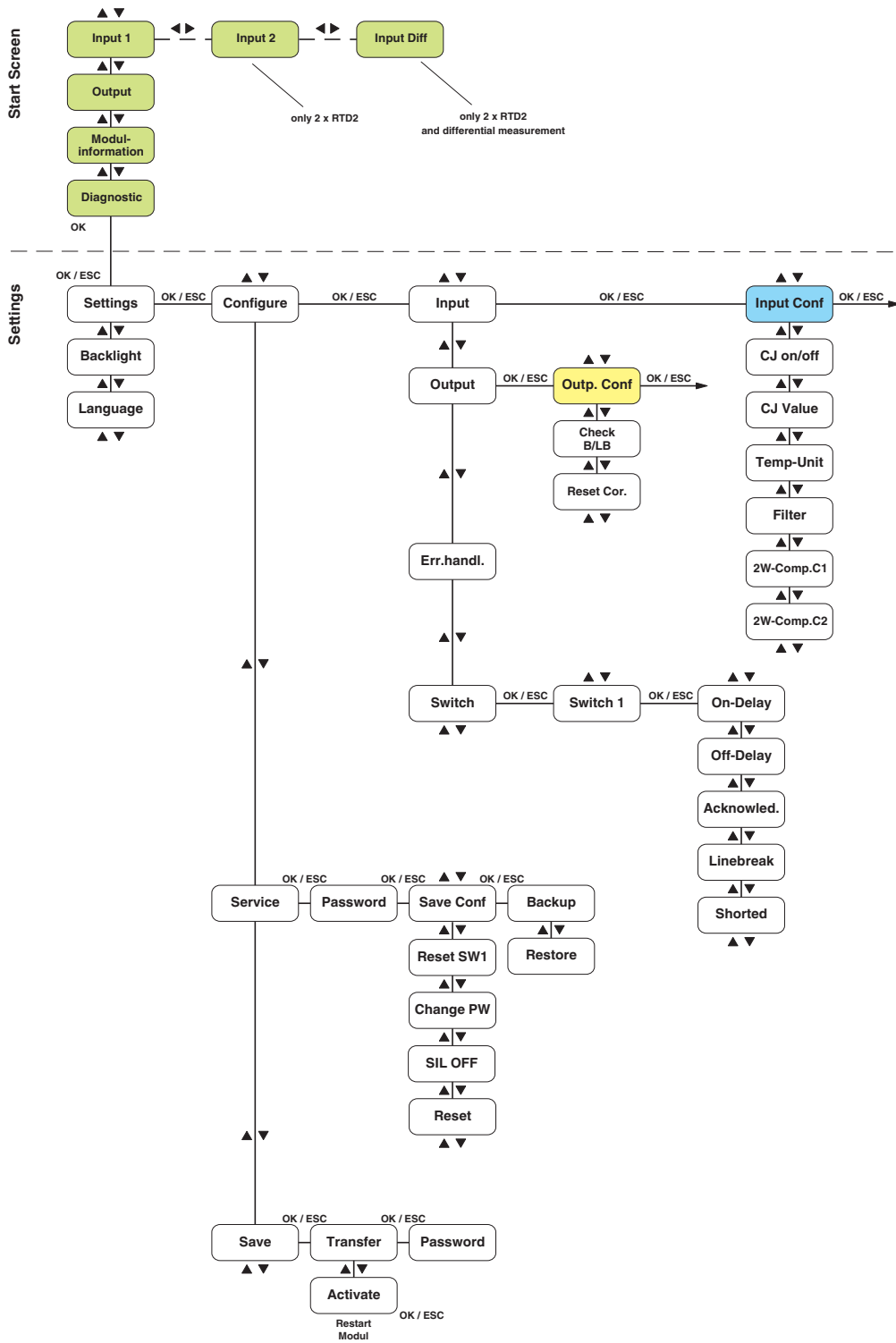

14.2 Key for start screen

Display of input and output signals, module and diagnostic information

Input 1	Display of the actual value of input 1
Input 2	Display of the actual value of input 2, only if a second RTD is configured in 2-wire connection technology
Input Diff	Display of the actual value of the differential measurement with 2 x RTD in 2-wire connection technology
Output	Display of the actual value for the analog output
Modul-information	Display of module information (order designation, firmware version, config version)
Diagnostic	Module diagnostics (simulation, module error, peripheral fault)

14.3 Key for SETTINGS - MENU

Settings	The active configuration is read out from the module
Backlight	Setting for the background illumination (on, off, autodim)
Language	Setting for the menu language (English, German)

14.4 Key for SETTINGS - Configure

Configure	Configuration of input, output, error handling, and switching outputs
------------------	-----------------------------------------------------------------------

14.5 Key for SETTINGS - Service

Service

Access to the menu items of the service area

Password

Input of a 4-digit numeric password in order to open the service area.
(If the password is 0000, the password prompt is switched off).

Save Conf

Access to the menu items for the backup and restore functions of the module configuration

Reset SW1

Resets switching output 1 when it is latched

Change PW

Changes the password set
(Change only becomes effective when the configuration has been transmitted to the module and activated)

SIL OFF

Changes the setting from SIL ON to SIL OFF



NOTE: It is only possible to switch on the SIL function via PC-based configuration software, e.g., IFS-CONF.

Reset

Resets the IFS-OP-UNIT and the connected module

Backup

Saves the active configuration of the connected, compatible module in the IFS-OP-UNIT operator interface (copy function)

Restore

Transmits the saved module configuration from the internal memory of the IFS-OP-UNIT operator interface to the connected module (copy function)



Then activate the configuration by selecting Yes in the Activate menu item.

14.6 Key for SETTINGS - Save

Save

Access to the menu items for the transmission and activation of the module configuration

Transfer

Transmits the configuration from the IFS-OP-UNIT operator interface to the connected module

Password

Input of a 4-digit numeric password in order to transmit the configuration.
(If the password is 0000, the password prompt is switched off).

Activate

Activation of the module configuration (Yes/No)



Following activation, the module performs a warm start.

14.7 Key for input

Input

Access to the menu items for the configuration of the input (see “Key for input configuration (analog input)” on page 35)

14.7.1 Key for input configuration (analog input)

Input Conf

Setting for the dependent parameters of the input mode, sensor type, start and end of range, associated inputs, switching behavior, switching points

CJ on/off

Cold junction compensation for TC + CJ and TC + CJ ext. (on, off)

CJ Value

Correction of the cold junction value for CJ = on, presetting of cold junction value for CJ = off (-20 ... 65 K)

Temp-Unit

Setting for the temperature unit (°C, °F)

Filter

Setting for the filter factor (1 ... 10)

2W-Comp.C1

Setting for the cable resistance for RTD 2-wire connection technology, channel 1 (0 ... 50 Ω)

2W-Comp.C2

Setting for the cable resistance for RTD 2-wire connection technology, channel 2 (0 ... 50 Ω)

Configuration selection: input configuration

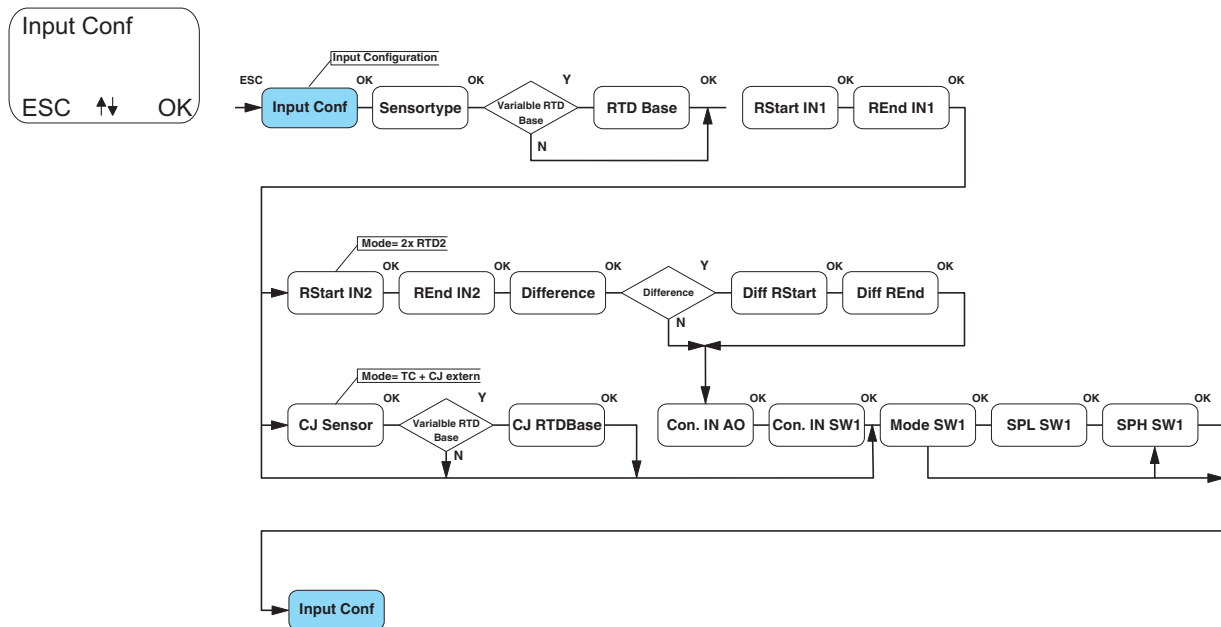

Input Conf	Setting for the sensor mode (RTD4, RTD3, RTD2, 2 x RTD2, TC + CJ, TC + CJ ext., potentiometer, mV).
Sensortype	Setting for the sensor type depending on the sensor mode (Pt, Ni, CU, KTY..., USER, for more see "Order key" on page 9).
RTD Base	RTD basic resistance for sensor types with a variable basic resistance (e.g., when 100 is selected, the basic resistance is 100 Ω)
RStart IN1	Start of range for input 1 depending on the sensor type, e.g., -50°C ($^{\circ}\text{C}$, $^{\circ}\text{F}$, Ω , %, mV).
REnd IN1	End of range for input 1 depending on the sensor type, e.g., 150°C ($^{\circ}\text{C}$, $^{\circ}\text{F}$, Ω , %, mV)
RStart IN2	Start of range for input 2 depending on the sensor type and only for 2 x RTD in 2-wire connection technology, e.g., -50°C ($^{\circ}\text{C}$, $^{\circ}\text{F}$, Ω).
REnd IN2	End of range for input 2 depending on the sensor type and only for 2 x RTD in 2-wire connection technology, e.g., 150°C ($^{\circ}\text{C}$, $^{\circ}\text{F}$, Ω)
Difference	Setting for the differential measurement only for 2 x RTD in 2-wire connection technology and not resistance (off, differential, absolute value differential)
Diff RStart	Start of range for differential, only with differential and absolute value differential ($^{\circ}\text{C}$, $^{\circ}\text{F}$)
Diff REnd	End of range for differential, only with differential and absolute value differential ($^{\circ}\text{C}$, $^{\circ}\text{F}$)
CJ Sensor	Sensor type of the cold junction, only with TC + CJ ext.
CJ RTDBase	RTD basic resistance of the cold junction, only with TC + CJ ext.
Con. IN AO	Associated input of the analog output (input 1, input 2, differential), appears only in sensor mode 2 x RTD2 (2 x RTD 2-wire connection technology)
Con. IN SW1	Associated input of the switching output (input 1, input 2, differential), appears only in sensor mode 2 x RTD2 (2 x RTD 2-wire connection technology)
Mode SW1	Mode of switching input (0 ... 7) (see "Switching output" on page 21)
SPL SW1	Setpoint low of switching output (appears only if mode >3) (see "Switching output" on page 21).
SPH SW1	Setpoint high of switching output (appears only if mode >1) (see "Switching output" on page 21)

14.8 Key for output

Output Access to the menu items for the configuration of the output (see “Key for output configuration (analog output)” on page 37)

14.8.1 Key for output configuration (analog output)

Outp. Conf Setting for the dependent parameters of the analog output – mode, start and end of range, display of correction values, error behavior (OR, UR, LB, SC)

Check B/LB Monitoring of output load/short circuit (**Yes/No**), only configurable with SIL = OFF

Reset Cor. Resets the correction values of the output

Configuration selection: output configuration

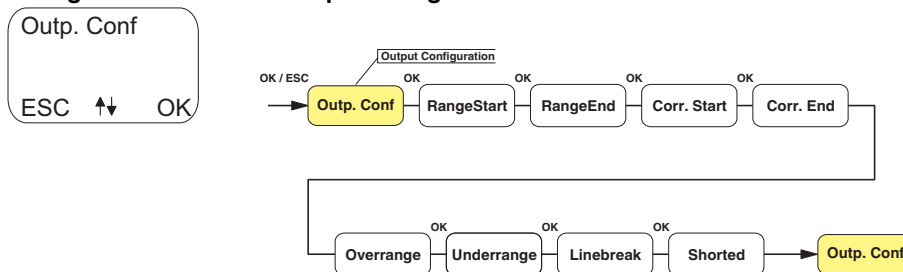

RangeStart Start of range for the output – setting only possible with SIL = OFF, **4 mA** (0 ... 20 mA, -10 ... 10 V)

RangeEnd End of range for the output – setting only possible with SIL = OFF **20 mA** (0 ... 20 mA, -10 ... 10 V)

Corr.Start Display of the start correction value for the analog output (mA, V)

Corr.End Display of the end correction value for the analog output (mA, V)

Overrange Analog output value in the event of overrange **NE43 Upsc.** / NE43 Downsc.
(Configurable for error behavior = freely definable)

Underrange Analog output value in the event of underrange **NE43 Upsc.** / NE43 Downsc.
(Configurable for error behavior = freely definable)

Linebreak Analog output value in the event of line break **NE43 Upsc.** / NE43 Downsc.
(Configurable for error behavior = freely definable)

Shorted Analog output value in the event of a short circuit on the line **NE43 Upsc.** / NE43 Downsc.
(Configurable for error behavior = freely definable)

14.9 Key for error behavior

Err.handl. Setting for the error behavior (NE43 increasing, NE43 decreasing, freely definable)

14.10 Key for switching output

Switch Access to the menu items for setting the switching output

Switch 1 Access to the menu items for setting the switching output

On-Delay Setting for the switch-on delay for the switching output (0 ... 10 s)

Off-Delay Setting for the switch-off delay for the switching output (0 ... 10 s)

Acknowled. Manually acknowledge switching output (latching) (Yes/**No**)

Linebreak Behavior of the switching output in the event of an error - line break (**on**, off, no response)

Shorted Behavior of the switching output in the event of an error - short circuit (**on**, off, no response)

15 Error codes of the IFS-OP-UNIT operator interface

The following error codes are shown directly on the display of the IFS-OP-UNIT operator interface when they occur.

Error code	Description
Error 0	Copy error Module type in the IFS-OP-UNIT is different from the connected module.
Error 1, 2, 3	Checksum error Please contact Phoenix Contact.

Appendix

A1 Safety-related applications (SIL 2)

Valid hardware and firmware versions



NOTE: Only those devices with SIL designation and module firmware with revision 0.92 or higher are certified for SIL 2.



NOTE: The evaluation unit following the measuring transducer (e.g., safety-related PLC) must recognize these states and correspondingly control the actuator as the final link in the safety chain.

SIL regulations apply to the following modules:

Designation	Order No.
Standard configuration	
MACX MCR-T-UI-UP	2811394
MACX MCR-T-UI-UP-SP	2811860
MACX MCR-T-UIREL-UP	2811378
MACX MCR-T-UIREL-UP-SP	2811828
MACX MCR-EX-T-UI-UP	2865654
MACX MCR-EX-T-UI-UP-SP	2924689
MACX MCR-EX-T-UI-UP	2865751
MACX MCR-EX-T-UIREL-UP-SP	2924799
Order configuration	
MACX MCR-T-UI-UP-C	2811873
MACX MCR-T-UI-UP-SP-C	2811970
MACX MCR-T-UIREL-UP-C	2811514
MACX MCR-T-UIREL-UP-SP-C	2811831
MACX MCR-EX-T-UI-UP-C	2811763
MACX MCR-EX-T-UI-UP-SP-C	2924692
MACX MCR-EX-T-UIREL-UP-C	2865722
MACX MCR-EX-T-UIREL-UP-SP-C	2924809

The safety-related temperature transducers listed above from the MACX MCR-(EX)-T-... series have been certified by TÜV Nord.

Certificate no.: SEBS-A.150520/17TB

A1.1 Safety function and safety requirements

The safety-related measuring transducers are used for the acquisition of a sensor signal (RTD, TC sensors, resistance-type sensors, mV sources [can be used with restrictions in SIL applications, see 1.6 "Functional restrictions"]), that is converted into a scaled signal and from which a standardized "live zero" current signal is generated. The entire conversion is continuously monitored to a maximum transmission error of 5%. In the event of greater deviations, the device switches to the safe state. The safe state is an output signal of either <math><3.6\text{ mA}</math> or $>21\text{ mA}$.

With the REL versions, an additional signal is generated, which is compared with up to two specified switching thresholds. When the first threshold is reached, the safety relay is switched on without checkback contact and when the second threshold is reached, it is switched off. Depending on the application, the safety for the switching output is implemented by either the series or parallel connection of relays 2 and 3 and a fuse connected in series, and by monitoring the calculated switching value.

If an N/O contact is required, the N/O contacts of relay 2 and relay 3 must be connected in series. In this way, the safe state (relay coil without power and N/O contact open) is also achieved in the event of a faulty contact (permanently closed) (see connection example 1).

If an N/C contact is required, the N/C contacts of relay 2 and relay 3 must be connected in parallel. In this way, the safe state (relay coil without power and N/C contact closed) is also achieved in the event of a faulty contact (permanently open) (see connection example 2).

In the event of deviations of more than 5%, the device switches to the safe state. The safe state in this case is a non-actuated relay.

The hardware is also continuously monitored. If an internal failure is detected, the measuring transducer also switches to the safe state (current output <math><3.6\text{ mA}</math> or $>21\text{ mA}$ or non-actuated relay).

The transition to the safe state always takes place within the internal fault detection time of 50 s.

The measuring transducer is released (restarted) by switching off the supply voltage and switching it back on again, by resetting the transducer via the serial interface, or by activating the "Restart" option during configuration. The integrated startup tests are then performed. If the fault is still present, it will be detected during these tests. If it is still present, the measuring transducer switches back to the safe state.

In addition to the safety functions, there are also monitoring functions for the input and the current output.

Evaluation

Faults which are detected in the measuring transducer and to which the transducer responds by switching to the safe state are safe faults (λ_s).

Faults where the measuring transducer does not follow a change of input signal or generates an output signal that deviates from the intended value by more than $\pm 5\%$, are evaluated as dangerous faults (λ_d).

Both safe (λ_s) and dangerous (λ_d) faults can be detected by diagnostic measures. Detected dangerous faults (λ_{dd}) are handled in the same way as safe faults.

The **monitoring functions** refer to events whose cause is detected and reported outside of the device.

Summary:

Safety/monitoring function	Output signal range	Safe state	Reason
Safety function	4 ... 20 mA	<3.6 mA or >21 mA relay is not actuated	Deviation >5%
Input monitoring	4 ... 20 mA	2 ... 3.6 mA, >21 mA	Line fault, input
Output monitoring	4 ... 20 mA	= 0 mA	Line fault, output

Together with the actual signal transmission, continuous checks and diagnostic functions are performed in the measuring transducers in order to detect faulty behavior.

Please note that the scope of monitoring functions is limited when using mV sources (see 1.6 "Functional restrictions").

The **internal fault monitoring time** (diagnostics test interval) is the time taken to carry out and repeat these tests in full. Random hardware faults are detected during this time.

The **internal fault monitoring time** is 50 seconds.

A1.2 Requirements on safety integrity



As a result of the multiple connection options, only two device types are considered in the following configurations for "RTD 3-wire" or "mV". They represent all configurations with a variable resistance at the input terminals or voltage or thermocouple inputs and always indicate the most conservative case. The two device types are:

1. MACX MCR(-EX)-T-UI-UP(-SP)(-C)
2. MACX MCR(-EX)-T-UIREL-UP(-SP)(-C)



FIT (failure in time)

1 FIT is one failure per 10^9 hours

Appendix - Safety-related applications (SIL 2)

A1.2.1 Failure rates, MACX MCR(-EX)-T-UIREL-UP (-SP)(-C)

Input: RTD 3-wire connection technology
Output: Switching outputs 2 and 3 (redundant)

- PL d
- Type B device (according to EN 61508-2)
- Safety integrity level (SIL) 2
- HFT = 0
- 1oo1d architecture

λ_{SD}	λ_{SU}	λ_{DD}	λ_{DU}	SFF	DC _D
0	$2.34 \cdot 10^{-7}$	$5.43 \cdot 10^{-7}$	$0.43 \cdot 10^{-7}$	94%	92%
0 FIT	234 FIT	543 FIT	43 FIT		

The total failure rate is: $1.34 \cdot 10^{-6}$

The MTBF (mean time between failures) is therefore 85 years.

The probability of a dangerous failure per hour for "continuous demand" mode and the average probability of failure of the specified function for "low demand" mode are determined based on the error rates:

PFD_{avg} values

T[PROOF] =	1 year	2 years	5 years
PFD _{avg} =	$2.88 \cdot 10^{-4}$	$4.67 \cdot 10^{-4}$	$1.01 \cdot 10^{-3}$

PFH* = $4.3 \cdot 10^{-8}$ /h

The calculation is performed assuming a checking interval (T_{PROOF}) of one year and a repair time (MTTR) of 24 hours, a test coverage (CPT) of 95%, and a lifetime (LT) of ten years.

On the basis of the value determined for the average probability of failure **PFD_{avg}**, the checking interval can be increased to up to five years.

The values are valid under the following conditions:

- The failure rates of the components used remain constant throughout the period of use.
- The propagation of errors by the device in the system is not taken into consideration.
- The repair time (= replacement) is 24 hours.
- The failure rates of the external power supply are not taken into consideration.
- The average temperature at which the device is to be used is +40°C. In this case, normal industrial conditions are assumed.
- The specified failure rates are based on an average ambient temperature of +40°C. For an average ambient temperature of +60°C, the failure rates must be multiplied by factor 2.5. Factor 2.5 is based on guide values.

1.2.2 Failure rates, MACX MCR(-EX)-T-UIREL-UP (-SP)(-C)

Please note that the scope of monitoring functions is limited when using mV sources (see 1.6 "Functional restrictions").

Input: Voltage input mV
Output: Switching outputs 2 and 3 (redundant)

- PL d
- Type B device (according to EN 61508-2)
- Safety integrity level (SIL) 2
- HFT = 0
- 1oo1d architecture

λ_{SD}	λ_{SU}	λ_{DD}	λ_{DU}	SFF	DC _D
0	$2.38 \cdot 10^{-7}$	$5.22 \cdot 10^{-7}$	$0.56 \cdot 10^{-7}$	93%	90%
0 FIT	238 FIT	522 FIT	56 FIT		

The total failure rate is: $1.34 \cdot 10^{-6}$

The MTBF (mean time between failures) is therefore 85 years.

The probability of a dangerous failure per hour for "continuous demand" mode and the average probability of failure of the specified function for "low demand" mode are determined based on the error rates:

PFD_{avg} values

T[PROOF] =	1 year	2 years	5 years
PFD _{avg} =	$3.67 \cdot 10^{-4}$	$5.99 \cdot 10^{-4}$	$1.30 \cdot 10^{-3}$

PFH* = $5.6 \cdot 10^{-8}$ /h

The calculation is performed assuming a checking interval (T_{PROOF}) of one year and a repair time (MTTR) of 24 hours, a test coverage (CPT) of 95%, and a lifetime (LT) of ten years.

On the basis of the value determined for the average probability of failure **PFD_{avg}**, the checking interval can be increased to five years if the percentage of the device for the entire loop is assumed to be 10%.

Appendix - Safety-related applications (SIL 2)

The values are valid under the following conditions:

- The failure rates of the components used remain constant throughout the period of use.
- The propagation of errors by the device in the system is not taken into consideration.
- The repair time (= replacement) is eight hours.
- The failure rates of the external power supply are not taken into consideration.
- The average temperature at which the device is to be used is +40°C. In this case, normal industrial conditions are assumed.
- The specified failure rates are based on an average ambient temperature of +40°C. For an average ambient temperature of +60°C, the failure rates must be multiplied by factor 2.5. Factor 2.5 is based on guide values.

1.2.3 Failure rates, MACX MCR(-EX)-T-UI-UP(-SP) (-C)

Input: RTD 3-wire connection technology

Output: 4 ... 20 mA (current output)

- Type B device (according to EN 61508-2)
- Safety integrity level (SIL) 2
- HFT = 0
- 1oo1d architecture

λ_{SD}	λ_{SU}	λ_{DD}	λ_{DU}	SFF	DC _D
0	0	$8.05 \cdot 10^{-7}$	$0.43 \cdot 10^{-7}$	94%	94%
0 FIT	0 FIT	805 FIT	43 FIT		

The total failure rate is: $1.18 \cdot 10^{-6}$

The MTBF (mean time between failures) is therefore 97 years.

The probability of a dangerous failure per hour for "continuous demand" mode and the average probability of failure of the specified function for "low demand" mode are determined based on the error rates:

PFD_{avg} values

T[PROOF] =	1 year	2 years	5 years
PFD _{avg} =	$2.95 \cdot 10^{-4}$	$4.76 \cdot 10^{-4}$	$1.02 \cdot 10^{-3}$

PFH* = $4.3 \cdot 10^{-8}$ /h

The calculation is performed assuming a checking interval (T_{PROOF}) of one year and a repair time (MTTR) of 24 hours, a test coverage (CPT) of 95%, and a lifetime (LT) of ten years.

On the basis of the value determined for the average probability of failure **PFD_{avg}**, the checking interval can be increased to up to five years.

The values are valid under the following conditions:

- The failure rates of the components used remain constant throughout the period of use.
- The propagation of errors by the device in the system is not taken into consideration.
- The repair time (= replacement) is eight hours.
- The failure rates of the external power supply are not taken into consideration.
- The average temperature at which the device is to be used is +40°C. In this case, normal industrial conditions are assumed.
- The specified failure rates are based on an average ambient temperature of +40°C. For an average ambient temperature of +60°C, the failure rates must be multiplied by factor 2.5. Factor 2.5 is based on guide values.

1.2.4 Failure rates, MACX MCR(-EX)-T-UI-UP(-SP) (-C)

Please note that the scope of monitoring functions is limited when using mV sources (see 1.6 "Functional restrictions").

Input: Voltage input mV

Output: 4 ... 20 mA (current output)

- Type B device (according to EN 61508-2)
- Safety integrity level (SIL) 2
- HFT = 0
- 1oo1d architecture

λ_{SD}	λ_{SU}	λ_{DD}	λ_{DU}	SFF	DC _D
0	0	$7.89 \cdot 10^{-7}$	$0.56 \cdot 10^{-7}$	93%	93%
0 FIT	0 FIT	789 FIT	56 FIT		

The total failure rate is: $1.19 \cdot 10^{-6}$

The MTBF (mean time between failures) is therefore 96 years.

The probability of a dangerous failure per hour for "continuous demand" mode and the average probability of failure of the specified function for "low demand" mode are determined based on the error rates:

PFD_{avg} values

T[PROOF] =	1 year	2 years	5 years
PFD _{avg} =	$3.75 \cdot 10^{-4}$	$6.08 \cdot 10^{-4}$	$1.31 \cdot 10^{-3}$

PFH* = $5.6 \cdot 10^{-8}$ /h

The calculation is performed assuming a checking interval (T_{PROOF}) of one year and a repair time (MTTR) of 24 hours, a test coverage (CPT) of 95%, and a lifetime (LT) of ten years.

On the basis of the value determined for the average probability of failure **PFD_{avg}**, the checking interval can be increased to up to five years.

Appendix - Safety-related applications (SIL 2)

The values are valid under the following conditions:

- The failure rates of the components used remain constant throughout the period of use.
- The propagation of errors by the device in the system is not taken into consideration.
- The repair time (= replacement) is eight hours.
- The failure rates of the external power supply are not taken into consideration.
- The average temperature at which the device is to be used is +40°C. In this case, normal industrial conditions are assumed.
- The specified failure rates are based on an average ambient temperature of +40°C. For an average ambient temperature of +60°C, the failure rates must be multiplied by factor 2.5. Factor 2.5 is based on guide values.

A1.3 Configuring an SIL device

The measuring transducer can be ordered with a standard configuration (see 1.) or with a configuration for safety-related applications (see 2.), or can be configured for safety-related applications by the user themselves (see 3.).

1. The measuring transducers are delivered with a standard configuration for safety-related applications with a 4 ... 20 mA output (see order key).
2. Customer-specific pre-configured devices (-C) can be delivered for both safety-related applications and “normal” usage. Configuration data is shown on a label.
3. The measuring transducers can also be configured by users for both safety-related applications and “normal” usage.

The configuration can be read out and changed at any time for all devices.



For safety-related applications, the password set in the factory must always be changed.
If the password is lost, it is not possible to change the configuration.
In this case, please contact Phoenix Contact.

Configuring safety-related applications

- Connect the device and PC with the help of the IFS-USB-PROG-ADAPTER programming adapter (Order No. 2811271).
- Access the ANALOG-CONF configuration software (free download: phoenixcontact.net/products).
For additional information on the FDT frame application (ANALOG-CONF) and the device drivers (DTM), please refer to the ANALOG-CONF user manual.
- Read out the active configuration.

- Enter the password in the ANALOG-CONF in the “PIN” hardware configuration (set to 1111 in the factory).
- Activate/deactivate SIL.

In the case of “SIL ON”, it is possible to deactivate the “Restart after failsafe” item here.

This means that in the event of a failure, the measuring transducer enters the failsafe state according to the safety functions, but is not restarted.

- Write the modified configuration data to the measuring transducer.
- Check that the new configuration data in the control window is correct and confirm with “OK” or “Cancel” if not correct.



NOTE: Installation, operation, and maintenance may only be carried out by qualified specialist personnel.



WARNING: If *Functional Safety* is activated by a reconfiguration or changes are made to the active *Functional Safety* configuration, the rules in Section “Installation and startup” must be observed.



WARNING: Limitations for safety-related applications

4 ... 20 mA only, limited programming of output current in the event of line faults ($2 \text{ mA} \leq I_{\text{Out}} \leq 3.6 \text{ mA}$ or $I_{\text{Out}} \geq 21 \text{ mA}$)



WARNING: Once new configuration data has been written, the device performs a warm start that changes the properties of the device. The following control device must be adapted to these modifications.



WARNING: The device must be write-protected to prevent improper use. Write protection is created by assigning a password.

A1.4 Installation and startup

During installation, always observe the packing slips

Designation	Order No.
PACKB.MACX MCR-T-UI-UP...	9055145
PACKB.MACX MCR-EX-T-UI-UP...	9055147
PACKB.MACX MCR-T-UIREL-UP...	9055146
PACKB.MACX MCR-EX-T-UIREL-UP...	9055148

The packing slip is provided with the device. It can also be downloaded at: phoenixcontact.net/products.

Lockable housing with IP54 protection is recommended for the installation of the measuring transducer.

- Check that the configuration of the measuring transducer is correct for the intended application.
- Connect the measuring transducer according to the installation notes.
- Make sure that the connected sensor corresponds to the configuration.
- Check the functionality of the measuring transducer with connected sensor for correct function.
A calibrated sensor simulator (RTD/TC) and a calibrated digital multimeter are necessary for checking the measuring transducer.
- Start up the loop and check that it operates correctly.

A1.5 Notes on operation

Only the green LED (PWR) is on during normal operation.

If a malfunction occurs during operation and the red LED (ERR) flashes, there is a line fault. The output current of the measuring transducer is between 2 ... 3.6 mA or is higher than 21.0 mA (in the case of faults in the sensor circuit) or is 0 mA (in the case of a line break in the output circuit).

The response of the relays depends on the connected sensor and on the error diagnostic options.

Check all signal lines. The device will automatically switch back to normal operation after the fault has been eliminated.

If a fault occurs during operation and the red LED (ERR) is permanently on, the device has switched to the "safe state" (output current is less than 2 mA).

Restart the device in order to set it to normal operation again.

- If no PC/laptop has been connected, you can also interrupt the power supply.
- Or you can carry out a warm start using the configuration software (*Service > Reset*).

The measuring transducer should then return to normal operation. If it does not, the measuring transducer must be replaced.

A1.6 Functional restrictions

Thermocouples

When connecting a thermocouple to the input, you can configure the input signals as a life zero signal. In this way, short circuit is detected as underrange.

mV input

When using the mV input, the input signal must be configured as a life zero signal. In this way, short circuit is detected as underrange.

Underrange therefore always is an error state.

When using the mV input, a resistance (10 k Ω / 0.6 W) must be connected between input terminals 5.1 and 5.2.

In this way, a sensor break is detected as underrange.

Underrange therefore always is an error state.

When using the mV input, only use switching behavior (SB) that is identical with the failsafe state (de-energized) in the event of a measured value of 0 mV (switching behavior 0, 2, 4, 6).

Other functional restrictions

Safe state = relay de-energized

Switching behavior 2 and 4:

- SPH (SB 2) or SPL (SB 4), minimum, 0 V +5% measuring span (e.g., 50 mV for -500 mV ... +500 mV span)
- Failsafe high not permitted on transducer
- Response to overrange at input is not possible

Switching behavior 6:

- SPL, minimum, 0 V +5% measuring span, SPH, maximum, maximum measuring span value

Appendix - Safety-related applications (SIL 2)

A1.7 Recurring checks (SIL 2)

The function of the entire safety loop must be checked regularly according to EN 61508 and EN 61511. The intervals for checking are specified by the intervals of each individual device within the safety loop.

It is the operator's responsibility to select the type of checks and the checking intervals in the specified time period.

The measuring transducers must be checked at least every seven years (maximum proof test interval).

Checking must be carried out in such a way that the correct function of the safety equipment in conjunction with all components can be verified.

Possible procedure for recurring checks for discovering dangerous and undetected device failures.

A calibrated sensor simulator (RTD/TC) and a calibrated digital multimeter are necessary for checking the measuring transducer.

- Connect the sensor simulator to the input of the measuring transducer using the appropriate connection technology.
- Connect the digital multimeter to the output in current measuring mode (20 mA range).

The measuring range limits and intermediate values are specified using the sensor simulator.

The corresponding output values of the measuring transducer must be checked on the digital multimeter.

Line faults (break and short circuit) are to be simulated on the input terminals; the configured residual currents are to be determined on the output.

If the function test result is negative, the measuring transducer must be taken out of operation and the process put into a safe state by other measures.

A1.8 Repair

The devices have a long service life, are protected against malfunctions, and are maintenance-free. However, if a device should fail, send it back to Phoenix Contact immediately. The type of malfunction and possible cause must also be stated.

Please use the original packaging or other suitable safe packaging when sending devices back for repairs or recalibration.

Phoenix Contact GmbH & Co. KG
Abteilung Service und Reparatur
Flachsmarktstr. 8
32825 Blomberg
GERMANY

A1.9 Standards (SIL 2)

The measuring transducers are developed and tested according to the following standards:

EN 61508:2001	Functional safety of electrical/electronic/programmable electronic safety-related systems
EN 61326-1:2006	Electrical equipment for measurement, control and laboratory use - EMC requirements
IEC 61326-3-2:2006	Electrical equipment for measurement, control and laboratory use – EMC requirements – Part 3-2: Immunity requirements for safety-related systems and for equipment intended to perform safety-related functions (functional safety) – Industrial applications with specified electromagnetic environment

Appendix - Safety-related applications (SIL 2)

A1.10 Abbreviations

Abbreviation		Meaning
DC _D	Diagnostic coverage of dangerous failures	Diagnostic coverage: $DC_D = \lambda_{DD} / (\lambda_{DU} + \lambda_{DD})$
HFT	Hardware fault tolerance	Hardware fault tolerance: ability of a function unit to continue with the execution of a demanded function despite existing faults or deviations
λ_D	Rate of dangerous failures	Proportion of dangerous failures per hour
λ_{DD}	Rate of dangerous detected failures	Proportion of detected dangerous failures per hour
λ_{DU}	Rate of dangerous undetected failures	Proportion of undetected dangerous failures per hour
λ_S	Rate of safe failures	Proportion of safe failures per hour
MTBF	Mean time between failures	Mean time between consecutive failures
PFD _{avg}	Average probability of failure on demand	Average probability of dangerous failure on demand of a safety function
PFH	Probability of a dangerous failure per hour	Probability of failure per hour for the safety function
SFF	Safe failure fraction	Proportion of safe failures: proportion of failures without the potential to set the safety-related system to a dangerous or impermissible function state
SIL	Safety integrity level	International standard IEC 61508 defines four discrete safety integrity levels (SIL 1 to 4). Each level corresponds to a probability range for the failure of a safety function. The higher the safety integrity level of safety-related systems, the lower the probability that the demanded safety functions will not be performed.



SCATTERGOOD & JOHNSON LTD

ELECTRICAL ENGINEERING & FLUID CONTROL DISTRIBUTORS

Est.1899

At Scattergood & Johnson Ltd, we pride ourselves on being a technical distributor to specialist industries.

Working with a range of quality product suppliers across a number of specialist markets, we are not your average 'box shifter' - we are your technical and supply chain partner.

We fully support every product we sell - for free! Our internal team and external sales engineers can answer any product or application question, no matter the complexity.

Backing up this technical ability is a range of 50,000+ products available from stock for nationwide next day delivery (same day if required!), or you can collect what you need from any of our trade counters around the UK.

Select your specialist interest below to learn more about how we can help.

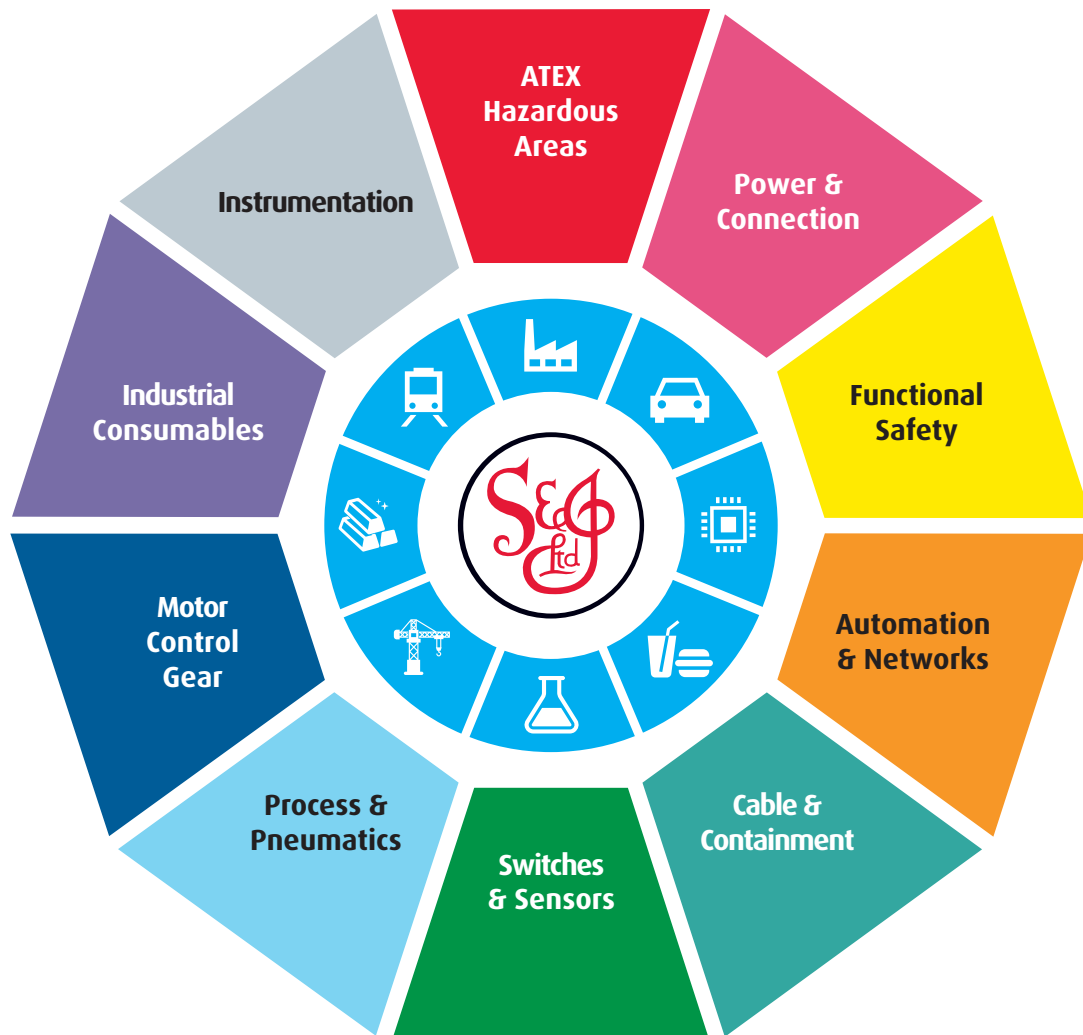

Online, In Branch and On the Road - Scattergood & Johnson Ltd, there when you need us.

www.scatts.co.uk