

EMD-FL-3V-400

Electronic monitoring relay for voltage monitoring in three-phase networks

INTERFACE

Data sheet
102110_en_03

© PHOENIX CONTACT - 09/2009



1 Description

Increasingly higher demands are being placed on safety and system availability – across all sectors. Processes are becoming more and more complex, not only in mechanical engineering and the chemical industry, but also in plant and automation technology. Demands on power engineering are also increasing constantly.

Error-free and therefore cost-effective operation can only be achieved through continuous monitoring of important network and system parameters. Electronic monitoring relays in the EMD series are available for a wide range of monitoring tasks to avoid the consequences of errors or to keep them within limits.

The operating states are indicated using colored LEDs, errors that may occur can be sent to a control system via a floating contact or can shut down a part of the system. Some device versions are equipped with startup and response delays in order to briefly tolerate measured values outside the set monitoring range.

Features

- Undervoltage monitoring
- Window function
- Phase sequence monitoring
- Phase failure monitoring
- Asymmetry monitoring
- Adjustable threshold values
- Adjustable response delay
- Wide-range power supply unit
- Two PDTs



WARNING: Risk of electric shock

Never carry out work when voltage is present.



Make sure you always use the the latest documentation.
It can be downloaded at www.phoenixcontact.net/download.

2 Ordering data

Description	Type	Order No.	Pcs. / Pkt.
Electronic monitoring relay for voltage monitoring in three-phase networks	EMD-FL-3V-400	2866064	1

3 Technical data

Input data	
Input name	Measuring input
Measured value	AC sine (48 Hz ... 63 Hz)
Protection	max. 20 A
Nominal input voltage U_N	(3 N ~ 400/230 V)
Maximum input voltage	(3 N ~ 600/346 V)
Input resistance of voltage input	1 M Ω
Maximum temperature coefficient	< 0.1 %/K
Setting range for response delay	0.1 s ... 10 s
Min. setting range	-30 % ... 20 % (From U_N)
Max. setting range	-20 % ... 30 % (From U_N)
Min setting range of the voltage threshold value	280 V AC ... 480 V AC
Max. setting range of the voltage threshold value	320 V AC ... 520 V AC
Function	Undervoltage, window, asymmetry, phase sequence, phase failure
Basic accuracy	\pm 5 % (of scale end value)
Setting accuracy	\leq 5 % (of scale end value)
Repeat accuracy	\leq 2 %
Asymmetry	5 % ... 25% / OFF
Recovery time	500 ms
Output data	
Contact type	2 floating PDT contacts
Nominal insulation voltage	250 V AC (in acc. with IEC 60664-1)
Interrupting rating (ohmic load) max.	750 VA (3 A/250 V AC, module aligned, \leq 5 mm spacing) 1250 VA (5 A/250 V AC, module not aligned, \geq 5 mm spacing)
Output fuse	5 A (fast-blow)
Supply	
Range of supply voltages	24 V AC ... 240 V AC -15 % ... +10 % 24 V DC ... 240 V DC -20 % ... +25 %
Frequency range	48 Hz ... 400 Hz
Nominal power consumption	4.5 VA (1.5 W)
General data	
Mains type	3-phase
Service life mechanical	Approx. 2×10^7 cycles
Service life, electrical	2×10^5 cycles at ohmic load, 1000 VA
Switching frequency	max. 60 (per minute at 100 VA ohmic load) max. 6 (per minute at 1000 VA ohmic load)
Operating mode	100% operating factor
Degree of protection	IP40 (housing) / IP20 (connection terminal blocks)
Pollution degree	2 (according to EN 50178)
Surge voltage category	III, basic insulation (as per EN 50178)

General data (Continued)

Rated insulation voltage	300 V (According to EN 50178)
Assembly	on TS 35 profile rail acc. to EN 60715
Mounting position	Any
Width	22.5 mm
Height	113 mm
Length	90 mm
Type of housing	Polyamide PA, self-extinguishing
Color	green
Weight	160 g

Connection data

Conductor cross section, solid	0.5 mm ² ... 2.5 mm ²
Conductor cross section, stranded	0.25 mm ² ... 2.5 mm ²
Stripping length	8 mm
Type of connection	Screw connection
Tightening torque	1 Nm

Ambient conditions

Ambient temperature (operation)	-25 °C ... 55 °C -25 °C ... 40 °C (corresponds to UL 508)
Ambient temperature (storage/transport)	-25 °C ... 70 °C
Permissible humidity (operation)	15 % ... 85 %
Climatic class	3K3 (in acc. with EN 60721)

Conformance / approvals

Conformity	CE compliant
UL, USA / Canada	UL/C-UL listed UL 508

Conformance with EMC directive 2004/108/EC

Immunity to interference according to	EN 61000-6-2
Emitted interference according to	EN 61000-6-4

Conformance with LV directive 2006/95/EC

Electronic equipm. for electrical power installations according to	EN 50178
--	----------

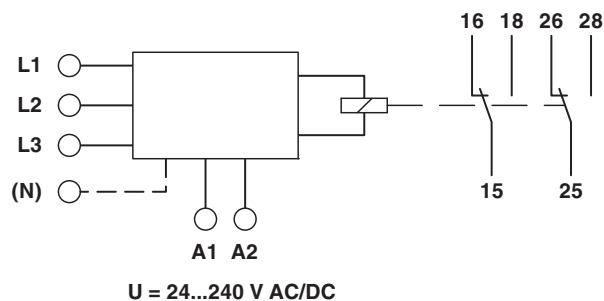
4 Block diagram

5 Safety notes



WARNING: Risk of electric shock

Never carry out work when voltage is present.

6 Structure

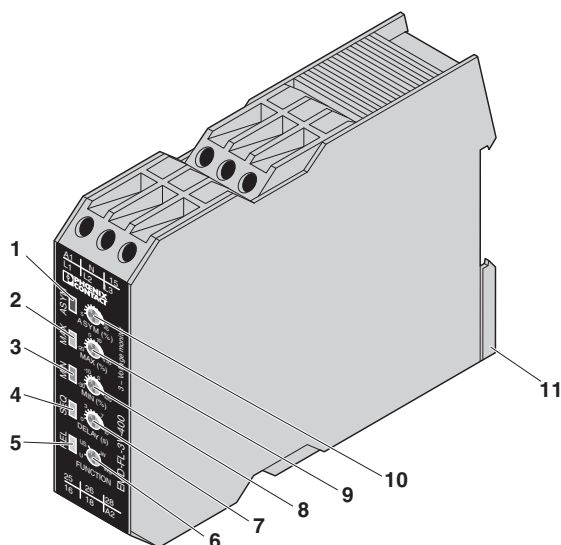

- 1 "ASYM" LED: Asymmetry
- 2 "MAX" LED: Upper threshold value
- 3 "MIN" LED: Lower threshold value
- 4 "SEQ" LED: Phase sequence
- 5 "REL" LED: Output relay
- 6 "FUNCTION" rotary switch: Function selection
- 7 "DELAY" potentiometer: Response delay
- 8 "MIN" potentiometer: Lower threshold value
- 9 "MAX" potentiometer: Upper threshold value
- 10 "ASYM" potentiometer: Asymmetry
- 11 Universal snap-on foot for EN DIN rails

7 Installation



WARNING: Risk of electric shock

Never carry out work when voltage is present.

The module can be snapped onto all 35 mm DIN rails according to EN 60715.

An integrated wide-range power supply unit enables the connection of a supply voltage in the range from 24 V AC/DC to 240 V AC/DC.

8 Diagnostics

The LEDs indicate the following error states:

"ASYM" LED (Red)

- LED flashes: Set threshold value exceeded, set delay time is running
- LED ON: Set threshold value exceeded, delay time has elapsed

"MIN" and "MAX" LEDs (Red)

- LED flashes: Set threshold value exceeded, set delay time is running
- LED ON: Set threshold value exceeded, delay time has elapsed
- Both LEDs flash alternately: Lower set threshold value is greater than upper threshold value

"SEQ" LED (Red)

- LED ON: Phases connected incorrectly. LED lights up immediately, relay drops out without delay.

"REL" LED (Yellow)

- LED ON: Output relay has picked up
- LED OFF: Output relay has dropped out

9 Connection examples

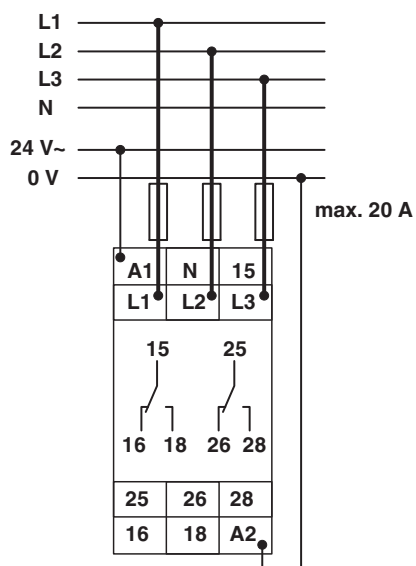

3(N) ~ 400 V/230 V measuring range, 24 V AC supply voltage

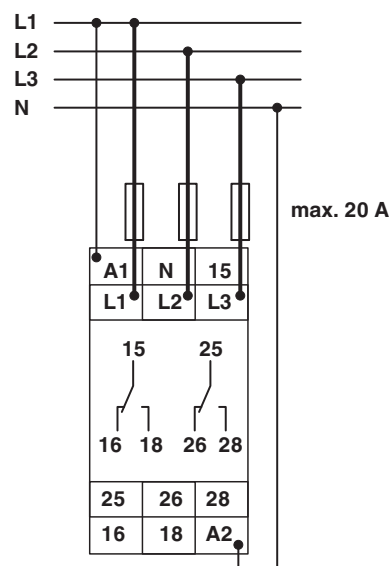

3(N) ~ 400 V/230 V measuring range, 230 V AC supply voltage

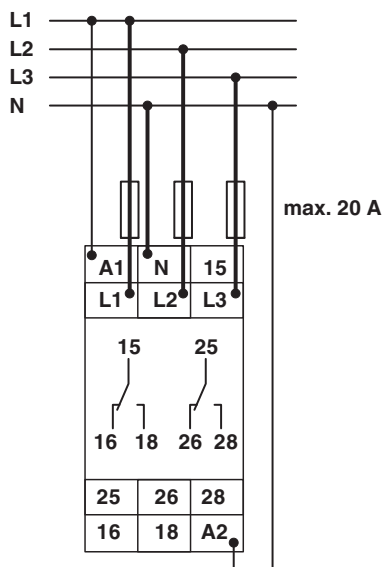

3(N) ~ 400 V/230 V measuring range with connected neutral conductor, 230 V AC supply voltage

10 Function

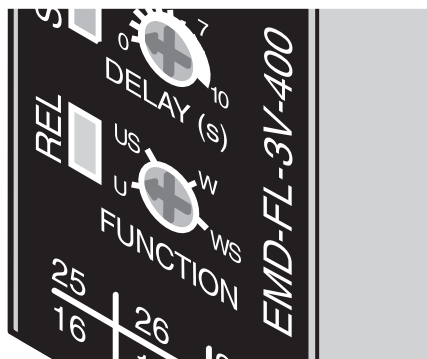

If an error is present when the monitoring module is activated, output relay "R" remains dropped out and the LED for the corresponding threshold value lights up.

For all functions the "MIN" and "MAX" LEDs flash alternately if the minimum value selected is greater than the maximum value.

The "FUNCTION" rotary switch is used to set the desired function:

- U = Undervoltage monitoring (UNDER)
- US = Undervoltage Monitoring With Phase Sequence and Phase Failure Monitoring (UNDER + SEQ)
- W = Monitoring of the area between thresholds MIN and MAX (window function) (WIN)
- WS = Monitoring of the area between thresholds MIN and MAX (window function) with phase sequence and phase failure monitoring (WIN + SEQ)

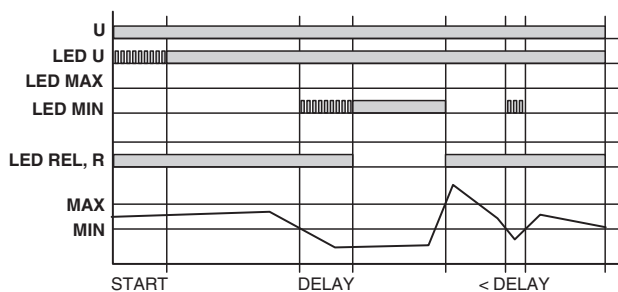

Undervoltage Monitoring (UNDER and UNDER + SEQ)

If the measured voltage (average value of the linked voltages) falls below the value set at the "MIN" controller, the set response delay (DELAY) starts (red "MIN" LED flashes). After the delay time has elapsed (red "MIN" LED is ON), output relay "R" drops out (yellow "REL" LED is OFF).

If the measured voltage exceeds the value set at the "MAX" controller, output relay "R" picks up again (yellow "REL" LED is ON).

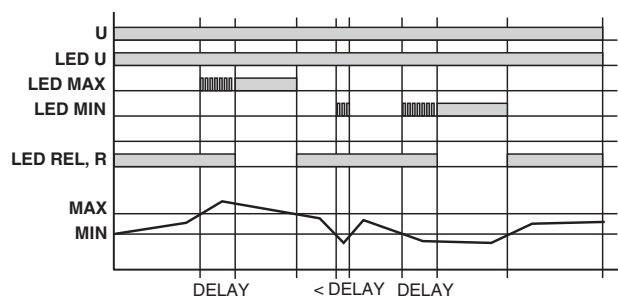

Window Function (WIN and WIN + SEQ)

Output relay "R" picks up (yellow "REL" LED is ON) if the measured voltage (average value of the linked voltages) exceeds the value set at the "MIN" controller. If the measured voltage exceeds the value set at the "MAX" controller, the set response delay (DELAY) starts (red "MAX" LED flashes). After the delay time has elapsed (red "MAX" LED is ON), output relay "R" drops out (yellow "REL" LED is OFF). Output relay "R" picks up again (yellow "REL" LED is ON) if the measured voltage falls below the maximum value again (red "MAX" LED is OFF). If the measured voltage falls below the value set at the "MIN" controller, the set response delay (DELAY) starts (red "MIN" LED flashes).

After the delay time has elapsed (red "MIN" LED is ON), output relay "R" drops out (yellow "REL" LED is OFF).

Phase Sequence Monitoring (SEQ)

Phase sequence monitoring can be enabled for all functions. In the event that the phase direction has been modified (red "SEQ" LED is ON), output relay "R" drops out without delay (yellow "REL" LED is OFF).

Phase Failure Monitoring (SEQ)

In the event that one of the phase voltages fails, the set response delay (DELAY) starts (red "SEQ" LED flashes). After the time delay has elapsed (red "SEQ" LED is ON), output relay "R" drops out (yellow "REL" LED is OFF). Reverse voltages (e.g., motors that continue running on two phases) are not detected using this function. This is done by monitoring asymmetry using a suitable selection of thresholds.

Asymmetry Monitoring

If the asymmetry of the linked voltages exceeds the value set at the "ASYM" controller, the set response delay (DELAY) starts (red "ASYM" LED flashes). After the delay time has elapsed (red "ASYM" LED is ON), output relay "R" drops out (yellow "REL" LED is OFF).

If a neutral conductor is connected, the asymmetry between the phase voltages (star voltage) and neutral conductor is also monitored. In this case both asymmetry values are used for evaluation. As soon as one of the two values exceeds the value set at the "ASYM" controller, the response delay starts (red "ASYM" LED flashes). After the delay time has elapsed (red "ASYM" LED is ON), output relay "R" drops out (yellow "REL" LED is OFF).

Neutral Conductor Break Monitoring Using Asymmetry Monitoring

A neutral conductor break between the system and supply network is detected as an asymmetry between the phase voltages and the neutral conductor, and the response delay (DELAY) starts (red "ASYM" LED flashes). After the delay time has elapsed (red "ASYM" LED is ON), output relay "R" drops out (yellow "REL" LED is OFF).

A neutral conductor break between this monitoring module and the monitored system cannot be detected.



SCATTERGOOD & JOHNSON LTD

ELECTRICAL ENGINEERING & FLUID CONTROL DISTRIBUTORS

Est.1899

At Scattergood & Johnson Ltd, we pride ourselves on being a technical distributor to specialist industries.

Working with a range of quality product suppliers across a number of specialist markets, we are not your average 'box shifter' - we are your technical and supply chain partner.

We fully support every product we sell - for free! Our internal team and external sales engineers can answer any product or application question, no matter the complexity.

Backing up this technical ability is a range of 50,000+ products available from stock for nationwide next day delivery (same day if required!), or you can collect what you need from any of our trade counters around the UK.

Select your specialist interest below to learn more about how we can help.



Online, In Branch and On the Road - Scattergood & Johnson Ltd, there when you need us.

www.scatts.co.uk