

ELR H5-.../500AC-...

Application note for hybrid motor starters



Application Note 105064_en_02

© PHOENIX CONTACT 2013-08-27

1 Description

The 3-phase hybrid motor starter ELR H5-.../500AC-... combines up to four functions into one:

- Right contactor
- Left contactor
- Motor overload protection relay
- EMERGENCY STOP up to PL e

As we do not know your application in detail, the application information and examples provided in this document are incomplete and serve only to provide you guidance, as an operator of safety-related control technology, in the implementation of safety standards and directives. The information and examples in this document make no claim to be complete nor are they legally binding.

For more detailed information, refer to the prevailing standards and directives that are applicable to your application.



Switching off the control voltage supply with a controlled motor always results in wear in the hybrid motor starter.

This switch should only be used if no more than 10,000 shutdowns can be expected over the entire lifespan system.



Make sure you always use the latest documentation.

It can be downloaded from the product at phoenixcontact.net/products.



This application note is valid for all products listed on the following page:

2 Table of Contents

1	Description.....	1
2	Table of Contents	2
3	Ordering data	3
4	Safety Notes	4
5	Use in connection with a frequency inverter.....	5
6	Example circuits for module group 1	6
6.1	Safety door / two-hand / EMERGENCY STOP application (single channel) with error prevention.....	6
6.2	EMERGENCY STOP (single channel) with error prevention	8
6.3	Safety door / two-hand / EMERGENCY STOP application (two channels).....	10
6.4	EMERGENCY STOP (two channels)	11
7	Safety Characteristics	12
7.1	For ELR H5-IES-	12
7.2	For ELR H5-ES-	13

3 Ordering data

Module group 1 with integrated safety technology, current measurement, and ATEX approval

Description	Type	Order No.	Pcs. / Pkt.
"4 in 1" hybrid motor starter for reversing 3~ AC motors up to 550 V AC, with 24 V DC input, 0.6 A output current, emergency stop function, and adjustable overload shutdown.	ELR H5-IES-SC-24DC/500AC-0,6	2900582	1
"4 in 1" hybrid motor starter for reversing 3~ AC motors up to 550 V AC, with 230 V AC input, 0.6 A output current, emergency stop function, and adjustable overload shutdown.	ELR H5-IES-SC-230AC/500AC-0,6	2900692	1
"4 in 1" hybrid motor starter for reversing 3~ AC motors up to 550 V AC, with 24 V DC input, 2.4 A output current, emergency stop function, and adjustable overload shutdown.	ELR H5-IES-SC-24DC/500AC-2	2900414	1
"4 in 1" hybrid motor starter for reversing 3~ AC motors up to 550 V AC, with 230 V AC input, 2.4 A output current, emergency stop function, and adjustable overload shutdown.	ELR H5-IES-SC-230AC/500AC-2	2900420	1
"4 in 1" hybrid motor starter for reversing 3~ AC motors up to 550 V AC, with 24 V DC input, 9 A output current, emergency stop function, and adjustable overload shutdown.	ELR H5-IES-SC-24DC/500AC-9	2900421	1
"4 in 1" hybrid motor starter for reversing 3~ AC motors up to 550 V AC, with 230 V AC input, 9 A output current, emergency stop function, and adjustable overload shutdown.	ELR H5-IES-SC-230AC/500AC-9	2900422	1
"4 in 1" hybrid motor starter for reversing 3~ AC motors up to 550 V AC, with 24 V DC input, 0.6 A output current, emergency stop function, adjustable overload shutdown, and push-in connection.	ELR H5-IES-PT- 24DC/500AC-0,6	2903902	1
"4 in 1" hybrid motor starter for reversing 3~ AC motors up to 550 V AC, with 24 V DC input, 2.4 A output current, emergency stop function, adjustable overload shutdown, and push-in connection.	ELR H5-IES-PT- 24DC/500AC-2	2903904	1
"4 in 1" hybrid motor starter for reversing 3~ AC motors up to 550 V AC, with 24 V DC input, 9 A output current, emergency stop function, adjustable overload shutdown, and push-in connection.	ELR H5-IES-PT- 24DC/500AC-9	2903906	1
"3 in 1" hybrid motor starter for reversing 3~ AC motors up to 550 V AC, with 24 V DC input, 0.6 A output current, and emergency stop function.	ELR H5-ES-SC-24DC/500AC-0,6	2900558	1
"3 in 1" hybrid motor starter for reversing 3~ AC motors up to 550 V AC, with 24 V DC input, 2.4 A output current, and emergency stop function.	ELR H5-ES-SC-24DC/500AC-2	2900559	1
"3 in 1" hybrid motor starter for reversing 3~ AC motors up to 550 V AC, with 24 V DC input, 9 A output current, and emergency stop function.	ELR H5-ES-SC-24DC/500AC-9	2900561	1

Module group 2 with integrated current measurement, without safety technology

Description	Type	Order No.	Pcs. / Pkt.
"3 in 1" hybrid motor starter for reversing 3~ AC motors up to 550 V AC, with 24 V DC input, 0.6 A output current, and adjustable overload shutdown.	ELR H5-I-SC- 24DC/500AC-0,6	2900573	1
"3 in 1" hybrid motor starter for reversing 3~ AC motors up to 550 V AC, with 230 V AC input, 0.6 A output current, and adjustable overload shutdown.	ELR H5-I-SC-230AC/500AC-0,6	2900691	1
"3 in 1" hybrid motor starter for reversing 3~ AC motors up to 550 V AC, with 24 V DC input, 2.4 A output current, and adjustable overload shutdown.	ELR H5-I-SC- 24DC/500AC-2	2900574	1
"3 in 1" hybrid motor starter for reversing 3~ AC motors up to 550 V AC, with 230 V AC input, 2.4 A output current, and adjustable overload shutdown.	ELR H5-I-SC-230AC/500AC-2	2900575	1
"3 in 1" hybrid motor starter for reversing 3~ AC motors up to 550 V AC, with 24 V DC input, 9 A output current, and adjustable overload shutdown.	ELR H5-I-SC- 24DC/500AC-9	2900576	1
"3 in 1" hybrid motor starter for reversing 3~ AC motors up to 550 V AC, with 230 V AC input, 9 A output current, and adjustable overload shutdown.	ELR H5-I-SC-230AC/500AC-9	2900578	1

4 Safety Notes

- When working on the device, observe the national safety rules and regulations for the prevention of accidents.
- Disregarding these safety regulations may result in death, serious personal injury or damage to equipment.
- The device may only be started up, assembled, modified or retrofitted by an authorized electrician.
- Before working on the device, disconnect the power.
- For emergency stop applications, the machine must be prevented from restarting automatically by a higher-level control system.
- During operation, parts of electrical switching devices carry hazardous voltages.
- During operation, the protective covers must not be removed from the electric switching devices!
- Please retain the instructions.
- The device is an associated item and must not be installed in potentially explosive areas. Adhere to the relevant safety regulations when setting up and operating the relevant equipment.
- The safety regulations applicable when motors are used in the Ex area must be complied with (ATEX directive 94/9/EC).
- If the "Automatic RESET" operating mode is used, the drive is switched on after the cooling time has elapsed provided there is one more activation signal. The cooling time is 20 minutes. An automatic restart is not permissible in the case of applications in the Ex-protection area.
- The device may not be subjected to mechanical and thermal loads that exceed the thresholds specified in the operating manual. If required, the device should be installed in an appropriate housing with suitable protection (e.g. IP54) according to IEC 60529/EN 60529 to provide protection against mechanical and electrical damage. Where dusts are present, the device must be installed in a suitable housing (at least IP64) in acc. with EN 61241.
- Installation should be carried out following the instructions given in this data sheet. The circuits inside the device must not be accessed during operation.
- The operating equipment cannot be repaired by the user and must be replaced by an equivalent device. Repairs may only be carried out by the manufacturer.
- The safety data and features provided according to the EC-type examination are listed after the technical data.
- The device carries out a diagnosis of the functions when the drive is being switched on or when it is switched off. In addition, an (electrically) skilled person or a skilled worker who is well acquainted with the relevant standards can conduct the "Motor overload protection" safety function test. For this test, the drive must be operated with forward or reverse running, thus interrupting the current flow in a conductor (e.g. by removing the fuse in the L1 or L3 phase). The hybrid motor starter then switches the drive off within a period of 1.5...2 s. The LEDs for forward or reverse running activation extinguish and the Err-LED and the reply output are set.
- The device must be secured with the help of an access protection during safety-related applications.
- Only use power supply units with safe isolation and SELV / PELV in accordance with EN 50178/VDE 0160 (SELV / PELV).
- Please observe the minimum permissible load current for safety-related applications:
 ELR H5-...ES.../500AC-0,6: ≥ 75 mA
 ELR H5-...ES.../500AC-2: ≥ 180 mA
 ELR H5-...ES.../500AC-9: ≥ 1.5 A

Scope of use:

In circuits in potentially dust-explosive areas of zones 21 and 22, it must be guaranteed that the equipment connected to this circuit complies with categories 2D or 3D or is certified as such.

This is a product for environment A (industry). In environment B (household), this device can cause undesired radio interference; in such a case, the user may be under obligation to implement appropriate measures.

5 Use in connection with a frequency inverter

Hybrid motor starters are to be used for switching and/or reversing of three-phase asynchronous motors.

The use before and/or after the frequency inverter (FI) is not permitted.

The internal measuring technology of the hybrid motor starters evaluates this combination as an error and the device indicates a fault.

6 Example circuits for module group 1



Since the control supply voltage or the control voltage of the hybrid motor starter is disconnected via a single channel, this type of installation acc. to SIL 3 (Cat. 3, Cat. 4) is permitted, only if error prevention for cross circuits is permitted. This is the case, for example, if the hybrid motor starter and the safety relay are installed in the same switch cabinet. If such error prevention is not permitted, the control supply voltage must be disconnected via two channels or two positions. (see 6.3 on page 10 und 6.4 on page 11).

6.1 Safety door / two-hand / EMERGENCY STOP application (single channel) with error prevention

Acc. to Cat. 3, SIL 3, PL e: ELR H5-.../500AC-... with a higher-level safety relay combination within a closed control cabinet (see Figure 1 and Figure 2).

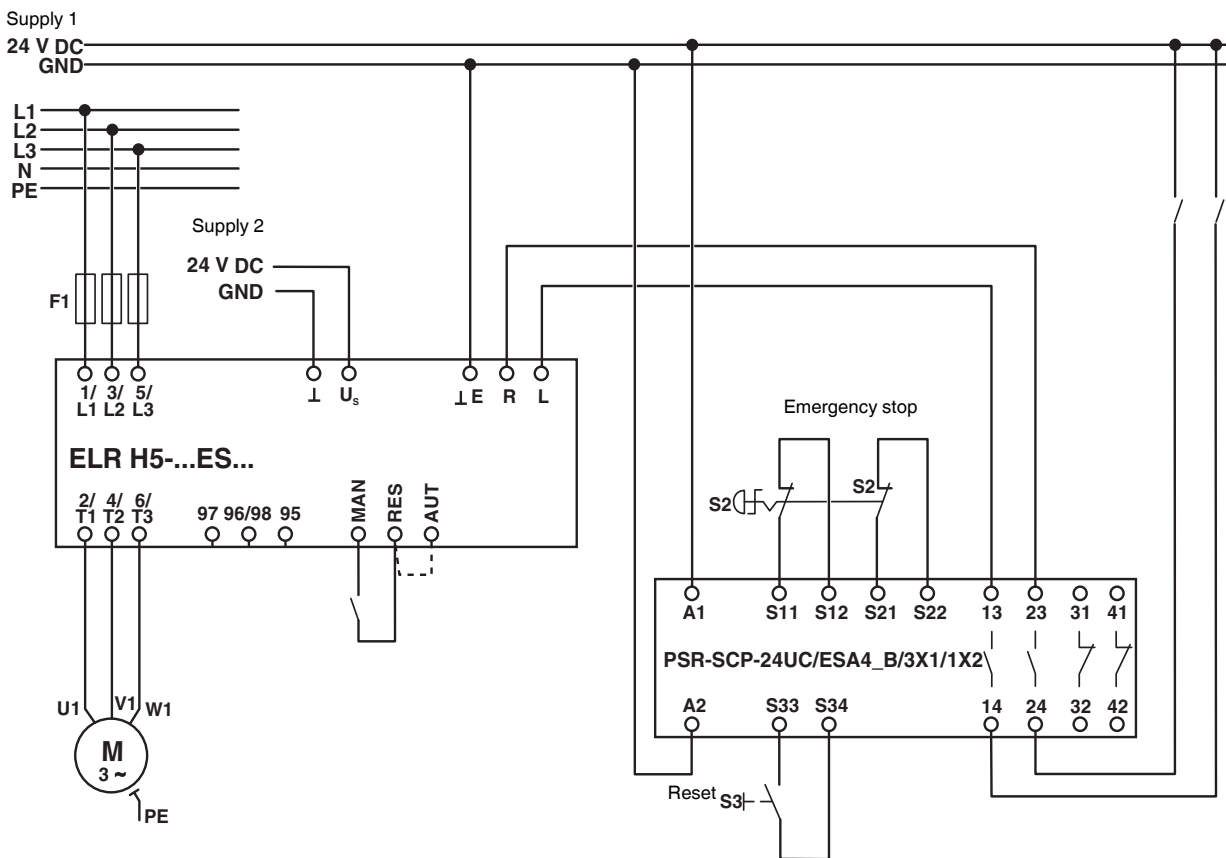

Figure 1 Safety door / two-hand / EMERGENCY STOP application (single channel) with error prevention (disconnect left/right rotation)

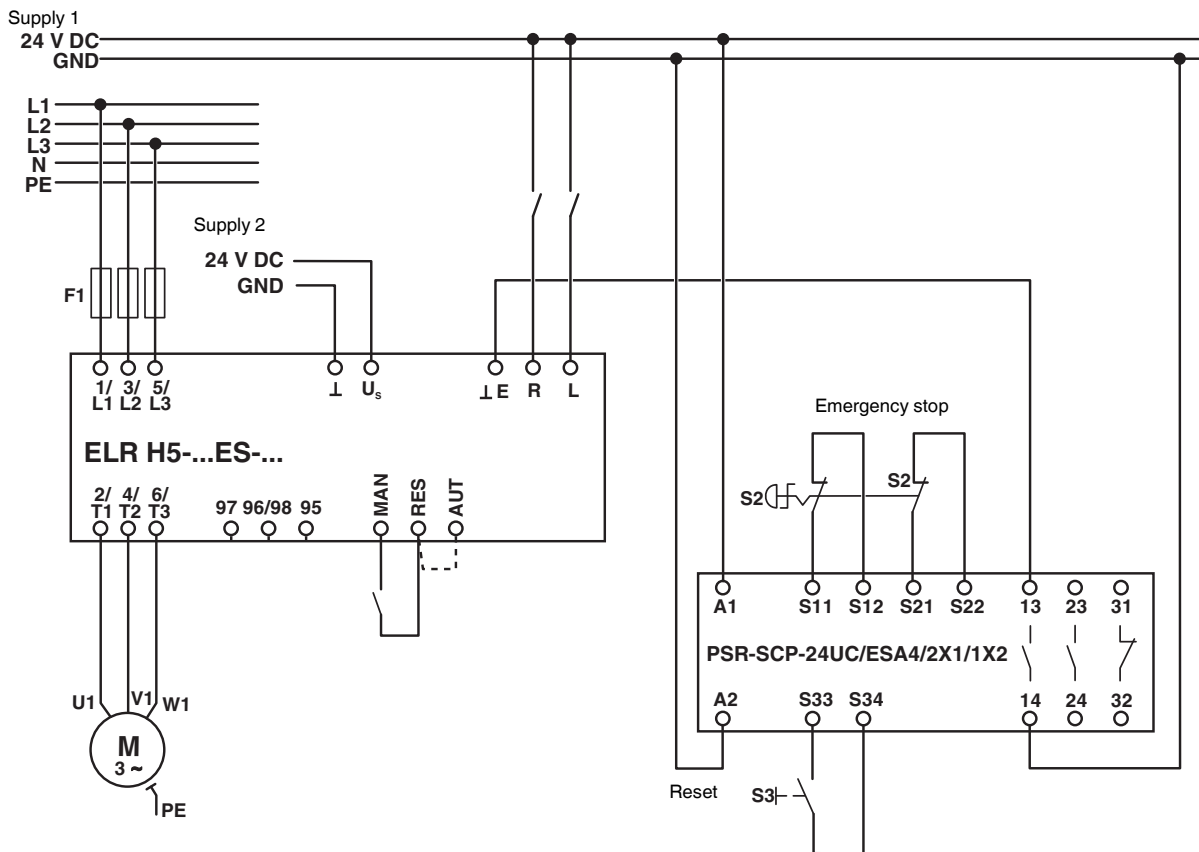

Figure 2 Safety door / two-hand / EMERGENCY STOP application (single channel) with error prevention (disconnect "Ground E")

6.2 EMERGENCY STOP (single channel) with error prevention

Acc. to Cat. 3, SIL 3, PL e: ELR H5-.../500AC-... with a higher-level safety relay combination within a closed control cabinet.

To reach the maximum service life, please apply the examples to disconnect the control voltage (see 6.1 on page 6).

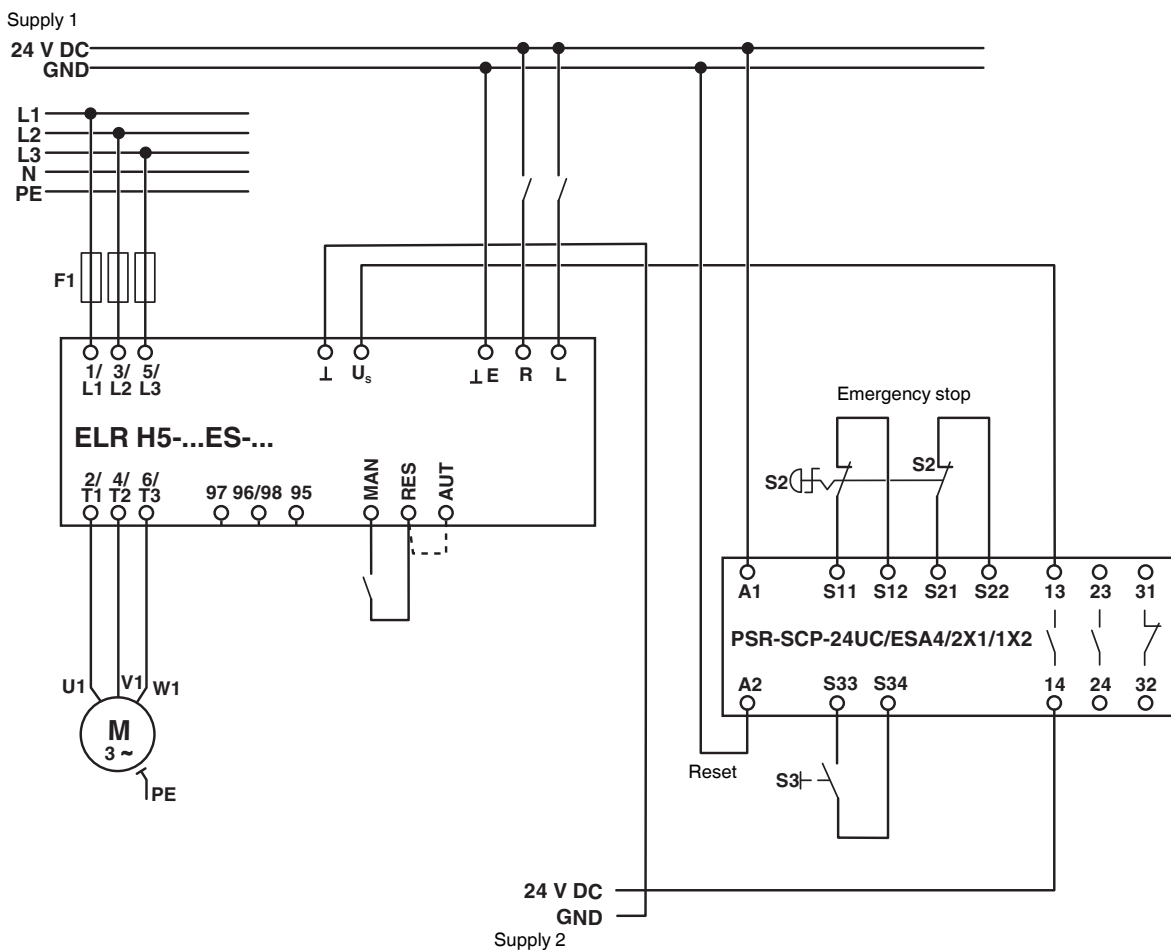

Figure 3 EMERGENCY STOP (single channel) with error prevention (disconnect U_s)

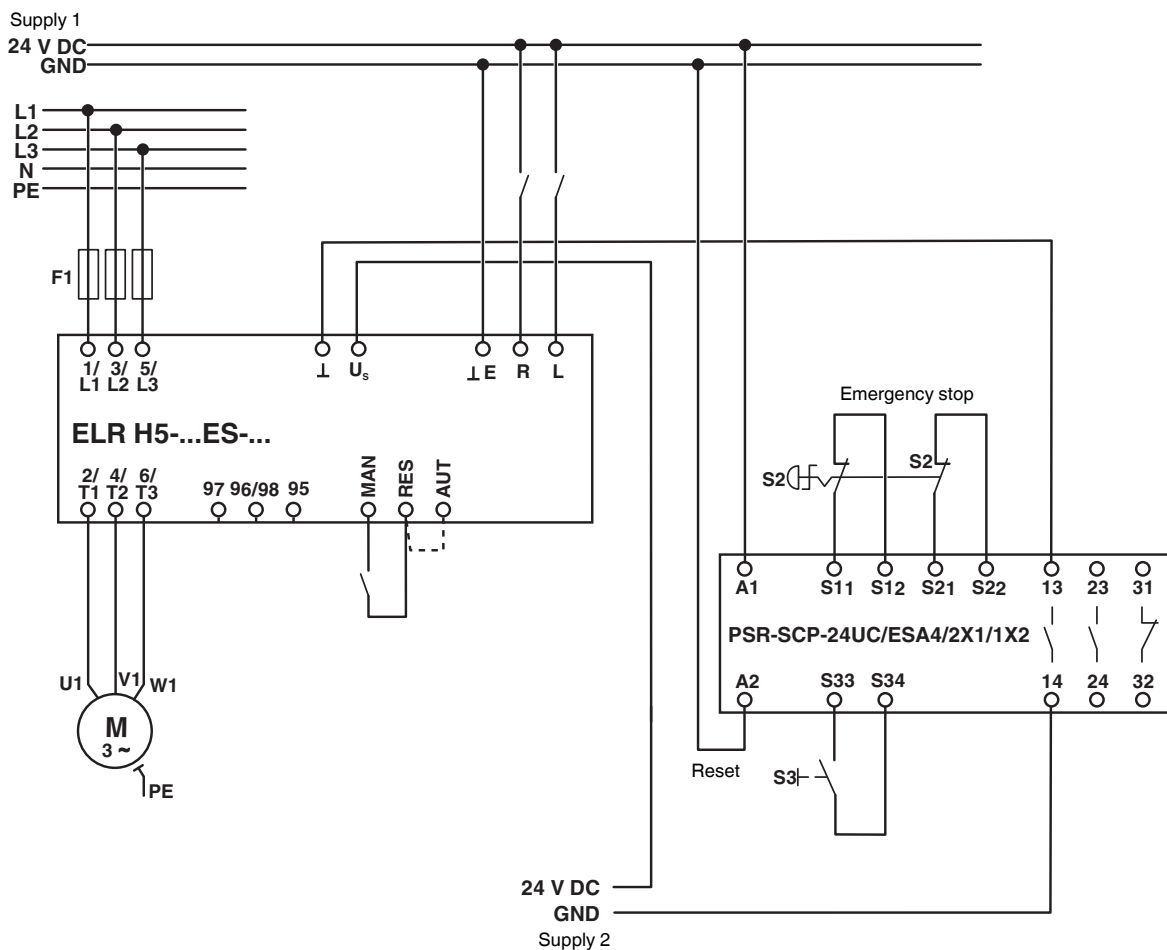

Figure 4 EMERGENCY STOP (single channel) with error prevention (disconnect Ground)

6.3 Safety door / two-hand / EMERGENCY STOP application (two channels)

Acc. to Cat. 3, SIL 3, PL e: ELR H5-.../500AC-... with a higher-level safety relay combination.

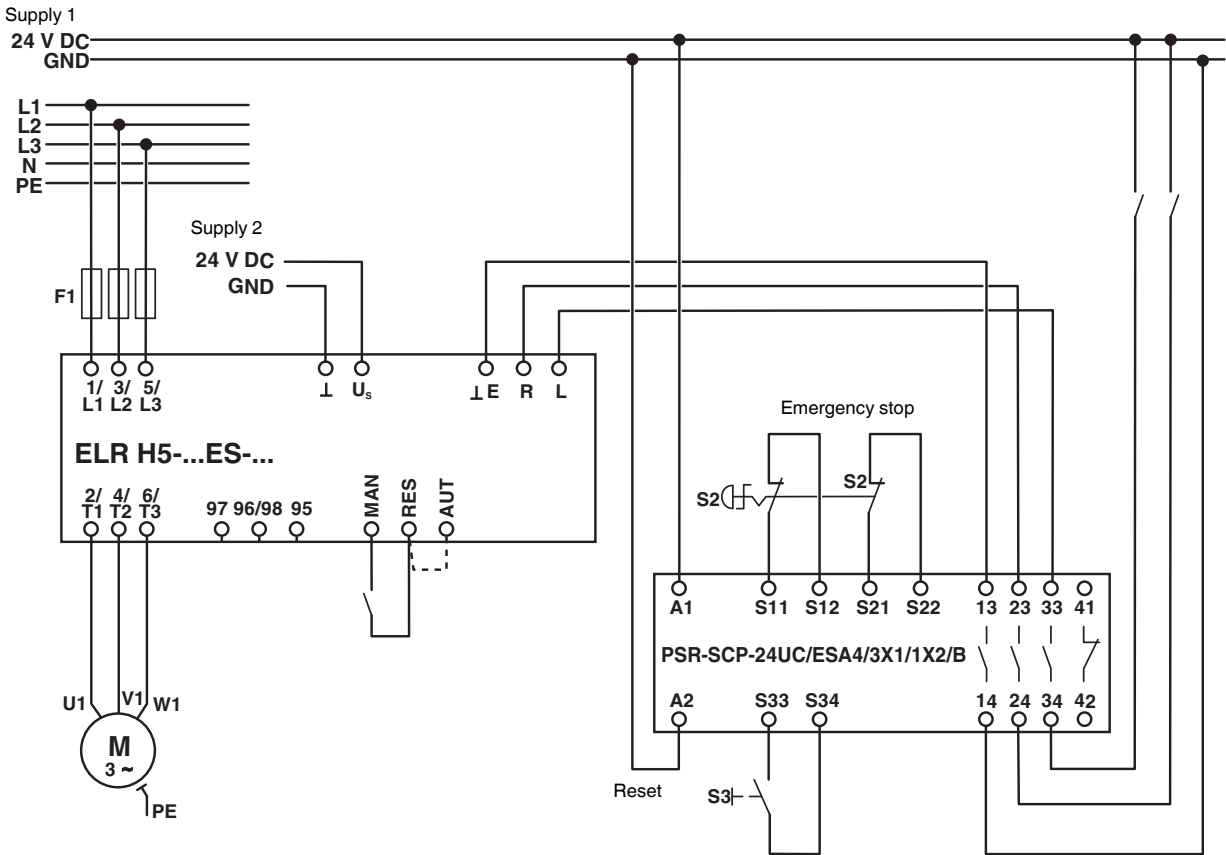

Figure 5 Safety door / two-hand / EMERGENCY STOP application (two channels)

6.4 EMERGENCY STOP (two channels)

Acc. to Cat. 3, SIL 3, PL e: ELR H5-.../500AC-... with a higher-level safety relay combination.

To reach the maximum service life, please apply the examples to disconnect the control voltage (see 6.3 on page 10).

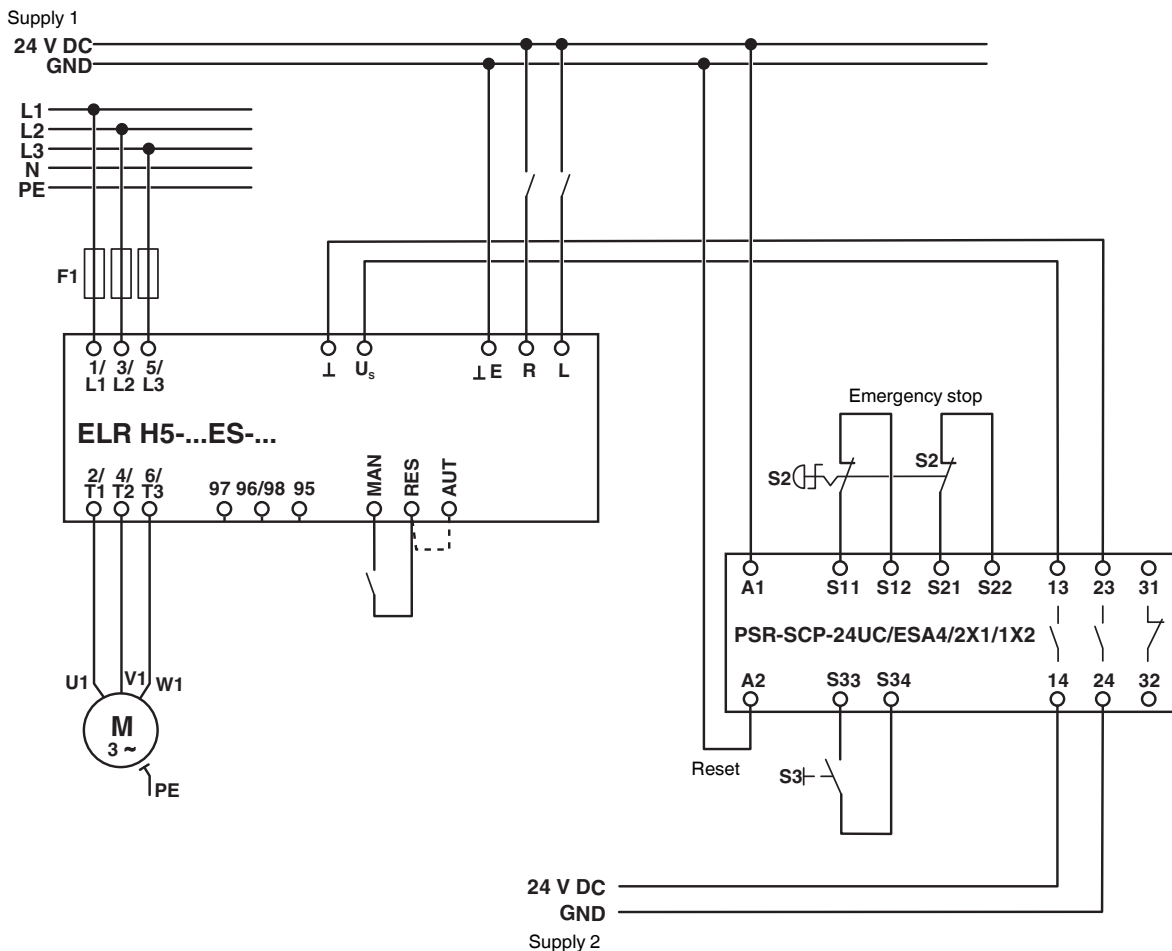

Figure 6 EMERGENCY STOP (two channels)

7 Safety Characteristics

7.1 For ELR H5-IES- ...

System conditions	
Database for failure rates	SN 29500
System type	Typ B, consisting of subsystems
Standard used	IEC 61508
Beta factor	1 %
MTTF [years] mean time to failure at an ambient temperature 40°C	39.3 (ELR H5-IES-...- 24DC/...) 39.1 (ELR H5-IES-...-230AC/...)

Safe switch-off	ELR H5-IES-...- 24DC/...	ELR H5-IES-...-230AC/...
Ambient temperature	40 °C	40 °C
MTTFd [Jahre] Mean time to failure	517	289
Switch-off time [ms]	80	100
λ_{sd} [FIT] safe, detectable	664	638
λ_{su} [FIT] safe, undetectable	968	935
λ_{dd} [FIT] dangerous, detectable	218	388
λ_{du} [FIT] dangerous, undetectable	2.67	6.82
SFF [%] Safe Failure Fraction	99	99
DCS [%] Diagnostic coverage safe	40.7	40.6
DC [%] Diagnostic coverage	98	98
PFH Probability of a dangerous failure per hour	2.67×10^{-9}	6.82×10^{-9}
Safety level as per	IEC 61508-1: SIL 3 ISO 13849-1: Category 3 PL e EN 954-1: Category 3	

7.2 For ELR H5-ES- ...

System conditions	
Database for failure rates	SN 29500
System type	Typ B, consisting of subsystems
Standard used	IEC 61508
Beta factor	1 %
MTTF [years] mean time to failure at an ambient temperature 40°C	39.3 (ELR H5-ES-...- 24DC/...)

Safe switch-off	ELR H5-ES-...- 24DC/...
Ambient temperature	40 °C
MTTFd [Jahre] Mean time to failure	517
Switch-off time [ms]	80
λ_{sd} [FIT] safe, detectable	664
λ_{su} [FIT] safe, undetectable	968
λ_{dd} [FIT] dangerous, detectable	218
λ_{du} [FIT] dangerous, undetectable	2.67
SFF [%] Safe Failure Fraction	99
DCS [%] Diagnostic coverage safe	40.7
DC [%] Diagnostic coverage	98
PFH Probability of a dangerous failure per hour	2.67×10^{-9}
Safety level as per	IEC 61508-1: SIL 3 ISO 13849-1: Category 3 PL e EN 954-1: Category 3



More safety-related data is available on request.



SCATTERGOOD & JOHNSON LTD

ELECTRICAL ENGINEERING & FLUID CONTROL DISTRIBUTORS

Est.1899

At Scattergood & Johnson Ltd, we pride ourselves on being a technical distributor to specialist industries.

Working with a range of quality product suppliers across a number of specialist markets, we are not your average 'box shifter' - we are your technical and supply chain partner.

We fully support every product we sell - for free! Our internal team and external sales engineers can answer any product or application question, no matter the complexity.

Backing up this technical ability is a range of 50,000+ products available from stock for nationwide next day delivery (same day if required!), or you can collect what you need from any of our trade counters around the UK.

Select your specialist interest below to learn more about how we can help.



Online, In Branch and On the Road - Scattergood & Johnson Ltd, there when you need us.

www.scatts.co.uk