

PSR-TRISAFE and CONTACTRON ELR-H3-IES.../ELR-H5-IES...

Safety-oriented and wear-free shutdown of the CONTACTRON hybrid motor starter with the PSR-TRISAFE safety module

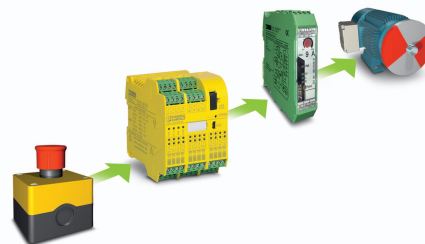

Application note
108168_en_01

© PHOENIX CONTACT 2018-06-08

1 Description

This application note is intended to assist you with the use of the PSR-TRISAFE safety modules, along with the hybrid motor starters in the CONTACTRON family.

When using PSR-TRISAFE safety modules, use hybrid motor starters of the type ELR-H3-IES...

or ELR-H5-IES...



The approved ELR types can be found in the section "Ordering data".

Application

The components used in your application have various functions.

The hybrid motor starter provides various control functions for the drive.

The safety module securely switches off the application after a safety function has been triggered or in the case of an error.

Task

In order to implement secure shutdown, the supply voltage of the hybrid motor starter must be switched off by the PSR-TRISAFE safety module.

Immediate shutdown of the supply voltage is associated with wear to or destruction of the hybrid motor starter, however.

Solution

To switch off the application using the PSR-TRISAFE safety module without causing any wear to the hybrid motor starter, be sure to follow a specified shutdown sequence. To this end, orient yourself on the application examples in this application note.



Make sure you always use the latest documentation. It can be downloaded at phoenixcontact.net/products.



This document is valid for products listed in the Section "Ordering data" on page 3.

Table of contents

1	Description.....	1
2	Ordering data.....	3
3	Documentation	4
4	Application examples.....	4
4.1	Application 1: PSR-TRISAFE with ELR-H3-IES.....	4
4.1.1	Safe shutdown	4
4.1.2	Wear-free shutdown.....	4
4.1.3	Wiring and parameterization notes.....	4
4.1.4	Application drawing and classification	5
4.1.5	Wiring and parameterization in SAFECONF	6
4.2	Application 1: PSR-TRISAFE with ELR-H5-IES.....	7
4.2.1	Safe shutdown	7
4.2.2	Wear-free shutdown.....	7
4.2.3	Wiring and parameterization notes.....	7
4.2.4	Application drawing and classification	8
4.2.5	Wiring and parameterization in SAFECONF	9
5	Revision history	10

2 Ordering data

PSR-TRISAFE safety module

Description	Type	Order No.	Pcs./Pkt.
Configurable safety module, non-expandable , DIN rail connector is included			
Module with screw connections	PSR-SCP-24DC/TS/S	2986229	1
Module with spring-cage connections	PSR-SPP-24DC/TS/S	2986232	1
Configurable safety module, expandable , DIN rail connector is included			
Module with screw connections	PSR-SCP-24DC/TS/M	2986012	1
Module with spring-cage connections	PSR-SPP-24DC/TS/M	2986025	1
Configurable safe extension module with parameterizable inputs/outputs , DIN rail connector is included with			
Module with screw connections	PSR-SCP-24DC/TS/SDI8/SDIO4	2986038	1
Module with spring-cage connections	PSR-SPP-24DC/TS/SDI8/SDIO4	2986041	1

CONTACTRON hybrid motor starter

Description	Type	Order No.	Pcs./Pkt.
Hybrid motor starter for starting 3~AC motors up to 500 V AC and 0.6 A output current, with 24 V DC control voltage, adjustable overload shutdown and emergency switching off function to SIL 3 / PL e, and screw connection.	ELR H3-IES-SC-24DC/500AC-0.6	2900566	1
Hybrid motor starter for starting 3~AC motors up to 500 V AC and 2.4 A output current, with 24 V DC control voltage, adjustable overload shutdown and emergency switching off function to SIL 3 / PL e and, screw connection.	ELR H3-IES-SC-24DC/500AC-2	2900567	1
Hybrid motor starter for starting 3~AC motors up to 500 V AC and 9A output current, with 24 V DC control voltage, adjustable overload shutdown and emergency switching off function to SIL 3 / PL e, and screw connection.	ELR H3-IES-SC-24DC/500AC-9	2900569	1
Hybrid motor starter for reversing 3~AC motors up to 500 V AC and 0.6 A output current, with 24 V DC control voltage, adjustable overload shutdown, emergency switching off function to SIL 3 / PL e, and screw connection.	ELR H5-IES-SC-24DC/500AC-0.6	2900582	1
Hybrid motor starter for reversing 3~AC motors up to 500 V AC and 2.4 A output current, with 24 V DC control voltage, adjustable overload shutdown and emergency switching off function to SIL 3 / PL e and screw connection	ELR H5-IES-SC-24DC/500AC-2	2900414	1
Hybrid motor starter for reversing 3~AC motors up to 500 V AC and 9 A output current, with 24 V DC control voltage, adjustable overload shutdown, emergency switching off function to SIL 3 / PL e, and screw connection.	ELR H5-IES-SC-24DC/500AC-9	2900421	1

3 Documentation



Observe the product documentation valid for the devices you are using.
Make sure you always use the latest documentation.
It can be downloaded at phoenixcontact.net/products.

4 Application examples

4.1 Application 1: PSR-TRISAFE with ELR-H3-IES...

4.1.1 Safe shutdown

The safety-oriented shutdown in the depicted application is implemented exclusively by switching off the supply voltage for the hybrid motor starter.

4.1.2 Wear-free shutdown

To switch off the CONTACTRON hybrid motor starter via the PSR-TRISAFE safety module, observe the following shutdown sequence:

1. Shutdown of the control signal at the **ON** input of the hybrid motor starter (not safety-oriented).
2. Delayed shutdown of the control supply voltage at the **U_S** input of the hybrid motor starter (safety-oriented).



Advanced shutdown of the **ON** control input serves to extend the service life of the CONTACTRON hybrid motor starter.

When the **U_S** is switched off, the cooling time stops. This can cause a quick triggering of the motor protection when starting the motor, shortly after voltage recovery.

4.1.3 Wiring and parameterization notes

- Connect the PLC control signal to a secure input of the PSR-TRISAFE safety module (in example **I3**).
- To switch off the control signal at the **ON** input, use a secure output of the PSR-TRISAFE safety module (in the example **O2**).
- The control input of the hybrid motor starter is thus controlled by the PLC signal via the PSR-TRISAFE safety module.
- Use the secure inputs of the PSR-TRISAFE safety module for the demand of the safety function (e. g. emergency switching off).
- To switch off the control supply voltage at the **U_S** input, use a secure output of the PSR-TRISAFE safety module (in the example **O0/O0-**).
- Parameterize a delay of **min** in the SAFECNF configuration software. **100 ms** for the output used (in the example **O0/O0-**).
- Establish the same reference ground for the hybrid motor starter and the PSR-TRISAFE safety module.
- Ensure an appropriate safeguard for motor leads **L1**, **L2** and **L3**.



Time delay

The delay for wear-free shutdown must be at least 100 ms. Take the delay into account when calculating the shutdown time of the PSR-TRISAFE system.

See user manual for UM DE PSR-TRISAFE system.

PSR-TRISAFE and CONTACTRON ELR-H3-IES.../ELR-H5-IES...

4.1.4 Application drawing and classification

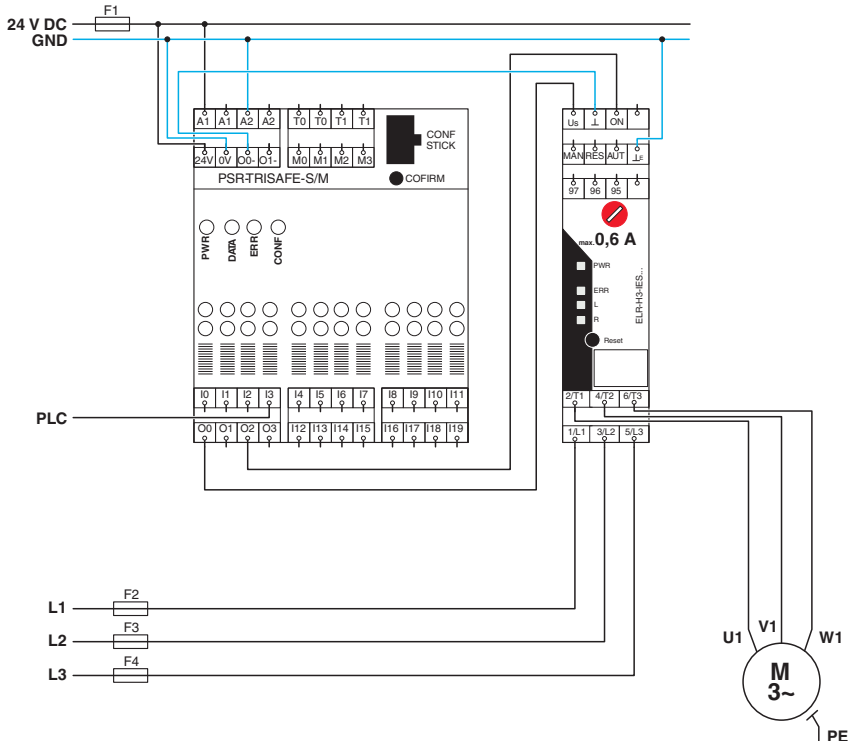

Figure 1 Circuit diagram PSR-TRISAFE with ELR-H3-IES...

Key:

Connections of PSR-TRISAFE

- A1/A2** Power supply connections
- 24V/0V** Power supply connections for secure outputs
- 00-** Ground switching output
- 00, O2** Safe digital outputs
- I3** Safe digital input

Connections ELR-H3-IES...

- U_S** Control supply voltage input
- ⊥** Ground reference point
- ON** Control Input
- ⊥_E** Control input reference point
- 2/T1, 4/T2, 6/T3** 3-phase output voltage
- 1/L1, 3/L2, 5/L3** 3-phase input voltage

Miscellaneous

- L1 ... L3** Motor leads
- U1, V1, W1** Motor phases
- F1 ... F4** External fuses
- PLC** PLC control signal

Safety level:

- Suitable up to category 3, PL e (EN ISO 13849-1), SIL 3 (EN 62061)

4.1.5 Wiring and parameterization in SAFECONF



For additional information and detailed step-by-step instructions for the SAFECONF configuration software, please refer to the online help of the software.

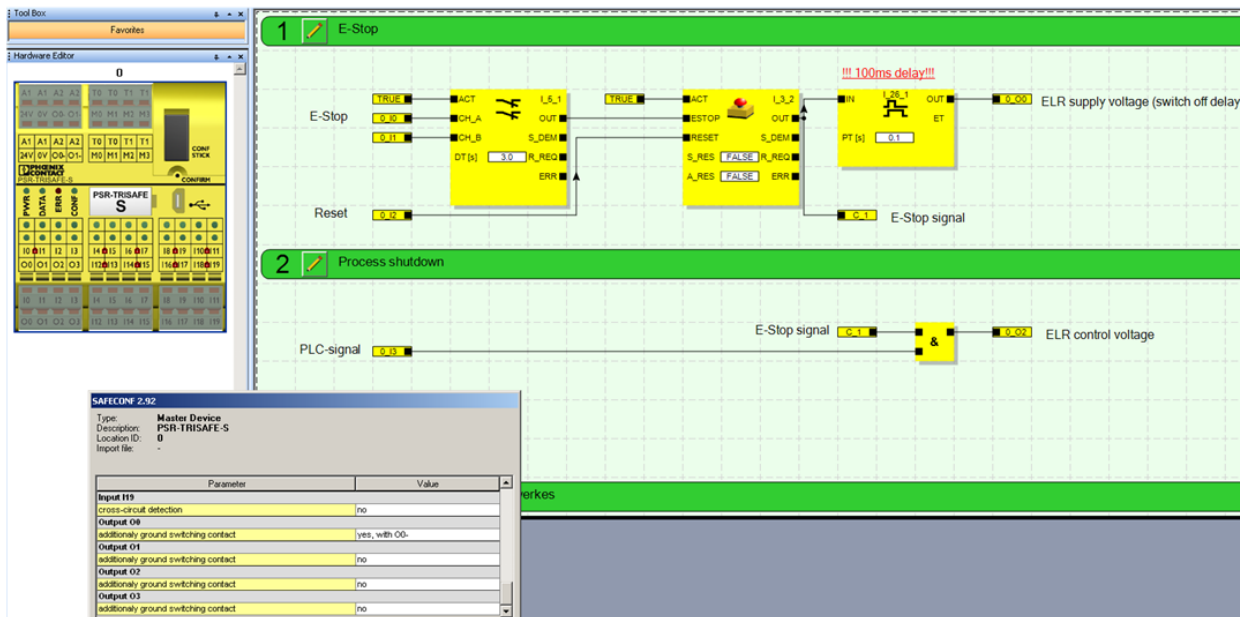

Figure 2 SAFECONF PSR-TRISAFE with ELR-H3-IES...

Key:

- 0_10 Input I0 for emergency switching off signal channel 1
- 0_11 Input I1 for emergency switching off signal channel 2
- 0_12 Input I2 for acknowledgement of the safety function
- C_1 Enable emergency switching off
- 0_00 Bipolar output O0/O0- for shutdown of the control supply voltage of the hybrid motor starter (U_G) with 100 ms delay
- 0_13 Input I3 for PLC control signal
- 0_02 Output O2 for control signal of hybrid motor starter (ON)

4.2 Application 1: PSR-TRISAFE with ELR-H5-IES...

4.2.1 Safe shutdown

The safety-oriented shutdown in the depicted application is implemented exclusively by switching off the supply voltage for the hybrid motor starter.

4.2.2 Wear-free shutdown

To switch off the CONTACTRON hybrid motor starter via the PSR-TRISAFE safety module, observe the following shutdown sequence:

3. Shutdown of the control signal at the **R** and **L** inputs of the hybrid motor starter (not safety-oriented).
4. Delayed shutdown of the control supply voltage at the **U_S** input of the hybrid motor starter (safety-oriented).



Advanced switching off of the **R** and **L** control inputs serves to extend the service life of the CONTACTRON hybrid motor starter.

When the **U_S** is switched off, the cooling time stops. This can cause a quick triggering of the motor protection when starting the motor, shortly after voltage recovery.

4.2.3 Wiring and parameterization notes

- Connect the PLC control signals to secure inputs of the PSR-TRISAFE safety module (in example **I3** and **I4**).
- To shut down the control signals at the **R** and **L** inputs, use secure outputs of the PSR-TRISAFE safety module (in the example **O2** and **O3**).
- The control inputs of the hybrid motor starter are thus controlled by the PLC signals via the PSR-TRISAFE safety module.
- Use the secure inputs of the PSR-TRISAFE safety module for the demand of the safety function (e. g. emergency switching off).
- To switch off the control supply voltage at the **U_S** input, use a secure output of the PSR-TRISAFE safety module (in the example **O0/O0-**).
- Parameterize a delay of **min** in the SAFECNF configuration software. **100 ms** for the output used (in the example **O0/O0-**).
- Establish the same reference ground for the hybrid motor starter and the PSR-TRISAFE safety module.
- Ensure an appropriate safeguard for motor leads **L1**, **L2** and **L3**.



The ground switching output **O1-** of the PSR-TRISAFE safety module is not required in practice. Leave **O1-** unwired.

PSR-TRISAFE and CONTACTRON ELR-H3-IES.../ELR-H5-IES...

4.2.4 Application drawing and classification

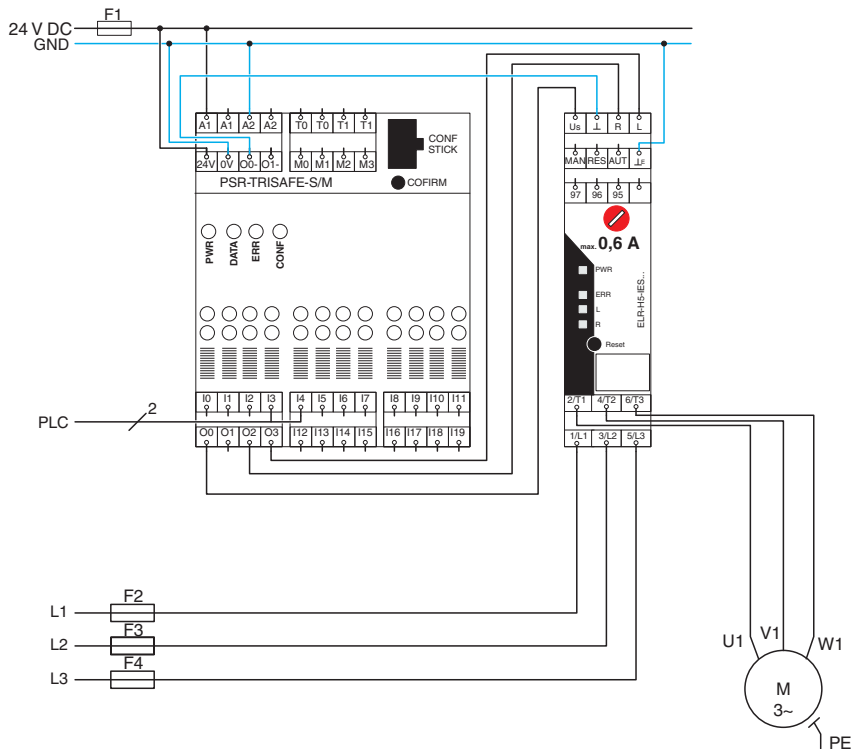

Figure 3 Circuit diagram PSR-TRISAFE with ELR-H5-IES...

Key:

Connections of PSR-TRISAFE

- A1/A2** Power supply connections
- 24V/0V** Power supply connections for secure outputs
- 00-** Ground switching output
- 00, 02, 03** Safe digital outputs
- I3, I4** Secure digital inputs

Connections ELR-H3-IES...

- U_S** Control supply voltage input
- ⊥** Ground reference point
- R** Forward running control input
- L** Control input: Reverse running
- ⊥_E** Control input reference point
- 2/T1, 4/T2, 6/T3** 3-phase output voltage
- 1/L1, 3/L2, 5/L3** 3-phase input voltage

Miscellaneous

- L1 ... L3** Motor leads
- U1, V1, W1** Motor phases
- F1 ... F4** External fuses
- PLC** PLC control signal

Safety level:

- Suitable up to category 3, PL e (EN ISO 13849-1), SIL 3 (EN 62061)

4.2.5 Wiring and parameterization in SAFECONF



For additional information and detailed step-by-step instructions for the SAFECONF configuration software, please refer to the online help of the software.

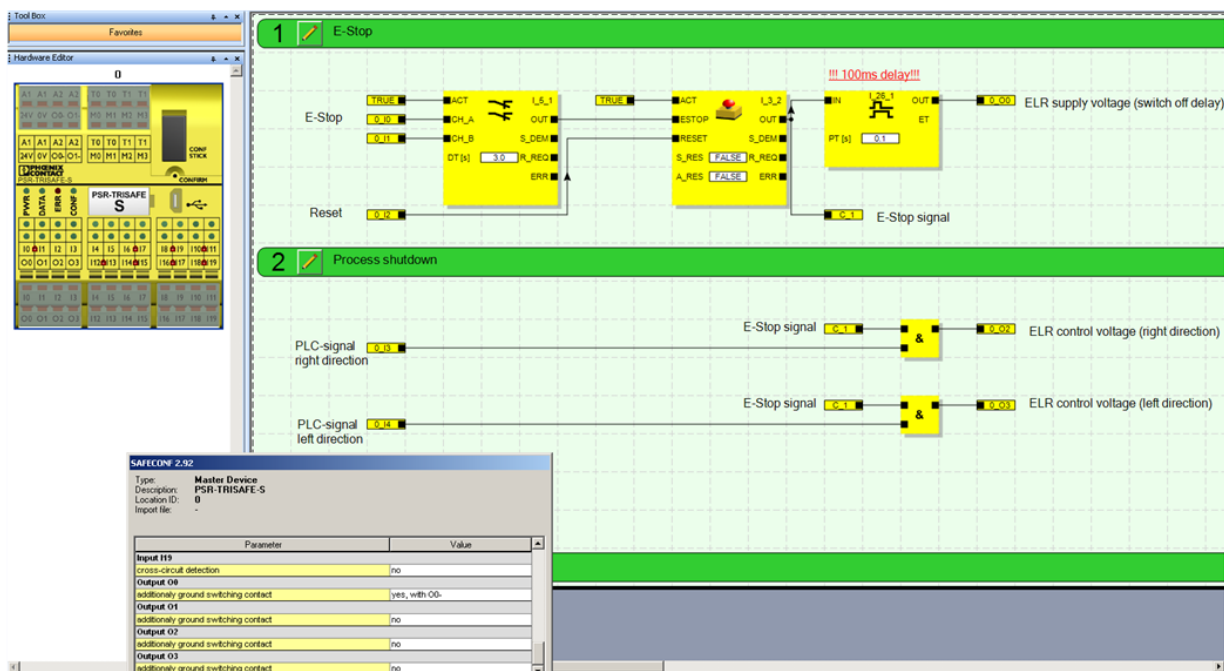

Figure 4 SAFECONF PSR-TRISAFE with ELR-H5-IES...

Key:

- 0_10 Input I0 for emergency switching off signal channel 1
- 0_11 Input I1 for emergency switching off signal channel 2
- 0_12 Input I2 for acknowledgement of the safety function
- C_1 Enable emergency switching off
- 0_00 Bipolar output O0/O0- for shutdown of the control supply voltage of the hybrid motor starter (U_S) with 100 ms delay
- 0_13 Input I3 for PLC control signal forward running
- 0_14 Input I4 for PLC control signal reverse running
- 0_02 Output O2 for forward running control signal of hybrid motor starter (R)
- 0_03 Output O3 for reverse running control signal of hybrid motor starter (L)

5 Revision history

Revision	Date	Contents
00	2017-10-06	First publication
01	2018-06-08	Figure 1 and figure 2 revised



SCATTERGOOD & JOHNSON LTD

ELECTRICAL ENGINEERING & FLUID CONTROL DISTRIBUTORS

Est.1899

At Scattergood & Johnson Ltd, we pride ourselves on being a technical distributor to specialist industries.

Working with a range of quality product suppliers across a number of specialist markets, we are not your average 'box shifter' - we are your technical and supply chain partner.

We fully support every product we sell - for free! Our internal team and external sales engineers can answer any product or application question, no matter the complexity.

Backing up this technical ability is a range of 50,000+ products available from stock for nationwide next day delivery (same day if required!), or you can collect what you need from any of our trade counters around the UK.

Select your specialist interest below to learn more about how we can help.



Online, In Branch and On the Road - Scattergood & Johnson Ltd, there when you need us.

www.scatts.co.uk