

Hybrid motor starter - ELR H5-I-SC-230AC/500AC-9 - 2900578

Please be informed that the data shown in this PDF Document is generated from our Online Catalog. Please find the complete data in the user's documentation. Our General Terms of Use for Downloads are valid (<http://phoenixcontact.com/download>)



Hybrid motor starter for reversing 3~ AC motors up to 550 V AC, with 230 V AC input, 9 A output current, and adjustable overload shutdown.

Your advantages

- 22.5 mm wide
- Space saving
- Long service life
- Reduction in wiring
- 3-phase loop bridges
- Adjustable current for bimetal function
- Low-wear switching



Key Commercial Data

Packing unit	1 pc
GTIN	 4 046356 528191
GTIN	4046356528191
Weight per Piece (excluding packing)	222.470 g
Custom tariff number	85371098
Country of origin	Germany

Technical data

Dimensions

Width	22.5 mm
Height	107 mm
Depth	114 mm

Ambient conditions

Ambient temperature (operation)	-25 °C ... 70 °C (observe derating)
Ambient temperature (storage/transport)	-40 °C ... 80 °C

Hybrid motor starter - ELR H5-I-SC-230AC/500AC-9 - 2900578

Technical data

Ambient conditions

Maximum altitude	≤ 2000 m
Degree of protection	IP20

Device supply

Rated control circuit supply voltage U_s	230 V AC
Control supply voltage range	85 V AC ... 253 V AC
Rated control supply current I_s	4 mA
Mains frequency	50/60 Hz
Type of protection	Surge protection

Input data

Input name	Control input right/left
Rated actuating voltage U_c	230 V AC
Triggering voltage range	85 V AC ... 253 V AC
Rated actuating current I_c	7 mA (Input type 1)
Mains frequency	50/60 Hz
Switching threshold	44 V AC ("0" signal)
	85 V AC ("1" signal)
Typical turn-off time	< 70 ms

Output data load output

Output name	AC output
Rated operating voltage U_e	500 V AC
Operating voltage range	42 V AC ... 550 V AC
Rated operating current I_e	9 A (AC-51)
	6.5 A (AC-53a)
Mains frequency	50/60 Hz
Load current range	1.5 A ... 9 A (see to derating)
Trigger characteristic in acc. with IEC 60947-4-2	Class 10A
Cooling time	20 min. (for auto reset)
Leakage current	0 mA
Type of protection	Surge protection

Output data reply output

Output name	Acknowledge output
Note	Confirmation: floating change-over contact, signal contact
Contact type	1 PDT
Switching capacity according to IEC 60947-5-1	3 A (230 V, AC15)
	2 A (24 V, DC13)

Overspeed tripping

Operate threshold	> 45 A
Response time	< 2 s

Hybrid motor starter - ELR H5-I-SC-230AC/500AC-9 - 2900578

Technical data

General

Motor starter type	Reversing starter
Switching frequency	≤ 2 Hz (Load-dependent)
Mounting position	vertical (horizontal DIN rail, motor output below)
Mounting type	DIN rail mounting
Assembly instructions	alignable, for spacing see derating
Operating mode	100% operating factor
Maximum power dissipation	16.1 W
Minimum power dissipation	2.6 W
Operating voltage display	Green LED
Status display	Yellow LED
Indication	Red LED

Connection data

Connection name	Control circuits
Connection method	Screw connection
Stripping length	8 mm
Screw thread	M3
Conductor cross section solid	0.2 mm ² ... 2.5 mm ²
Conductor cross section flexible	0.2 mm ² ... 2.5 mm ²
Conductor cross section AWG	24 ... 14
Torque	0.5 Nm ... 0.6 Nm
	5 lb _f -in. ... 7 lb _f -in.

Connection data 2

Connection name	Load circuit
Connection method	Screw connection
Stripping length	8 mm
Screw thread	M3
Conductor cross section solid	0.2 mm ² ... 2.5 mm ²
Conductor cross section flexible	0.2 mm ² ... 2.5 mm ²
Conductor cross section AWG	24 ... 14
Torque	0.5 Nm ... 0.6 Nm
	5 lb _f -in. ... 7 lb _f -in.

Insulation characteristics

Rated insulation voltage	500 V
Rated surge voltage	4 kV
Overvoltage category	III
Degree of pollution	2
Designation	Insulation characteristics between the control input and control supply voltage, and auxiliary circuit to the main circuit
Insulation	Safe isolation (IEC 60947-1) at operating voltage ≤ 300 V AC

Hybrid motor starter - ELR H5-I-SC-230AC/500AC-9 - 2900578

Technical data

Insulation characteristics

	Safe isolation (EN 50178) at operating voltage ≤ 300 V AC
	Basic isolation (IEC 60947-1) at operating voltage 300 ... 500 V AC
	Safe isolation (EN 50178) at operating voltage 300 ... 500 V AC
Designation	Isolation characteristics between the control input and control supply voltage to auxiliary circuit
Insulation	Safe isolation (IEC 60947-1) in the auxiliary circuit ≤ 300 V AC
	Safe isolation (EN 50178) in the auxiliary circuit ≤ 300 V AC

Standards and Regulations

Designation	Standards/regulations
Standards/regulations	IEC 60947-1
	IEC 60947-4-2
	IEC 61508
	ISO 13849

Conformance/approvals

Designation	UL approval
Certificate	NLDX.E228652

UL data

SCCR	100 kA (500 V AC (fuse: 30 A class CC/30 A class J (high fault)))
	5 kA (500 V AC (fuse: 20 A RK5 (standard fault)))
FLA	6.5 A (500 V AC)
Group installation	20 A (class RK5, SCCR 5kA, #24 - 14 AWG max. solid and stranded)
	30 A (class CC or J, SCCR 100kA, #24 - 14 AWG max, solid and stranded)
Category code	NLDX / NRNT

Environmental Product Compliance

REACH SVHC	Lead 7439-92-1
China RoHS	Environmentally Friendly Use Period = 50
	For details about hazardous substances go to tab "Downloads", Category "Manufacturer's declaration"

Drawings

Hybrid motor starter - ELR H5-I-SC-230AC/500AC-9 - 2900578

Circuit diagram

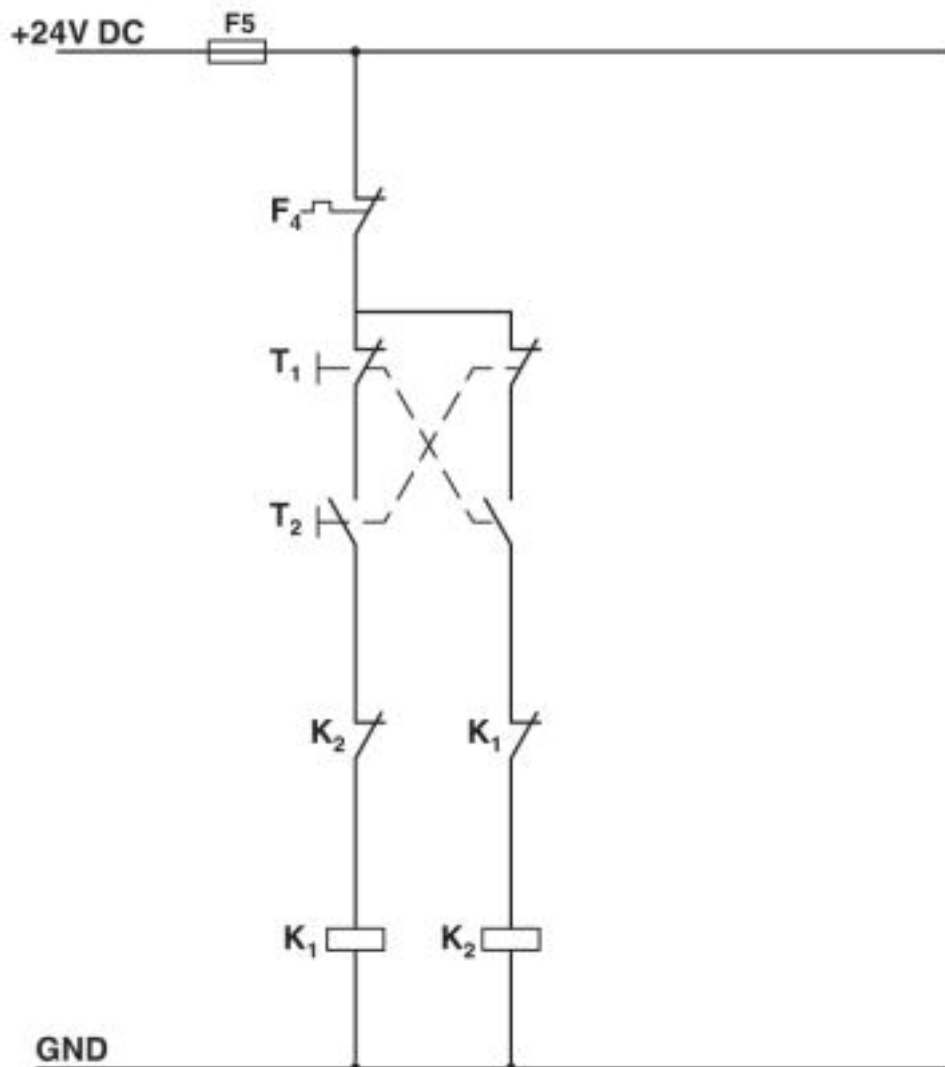

Conventional structure
 Control current path contactor
 K1 = Left contactor
 K2 = Right contactor
 T1 = Left, T2 = Right
 F4 = Motor protection relay

Hybrid motor starter - ELR H5-I-SC-230AC/500AC-9 - 2900578

Circuit diagram

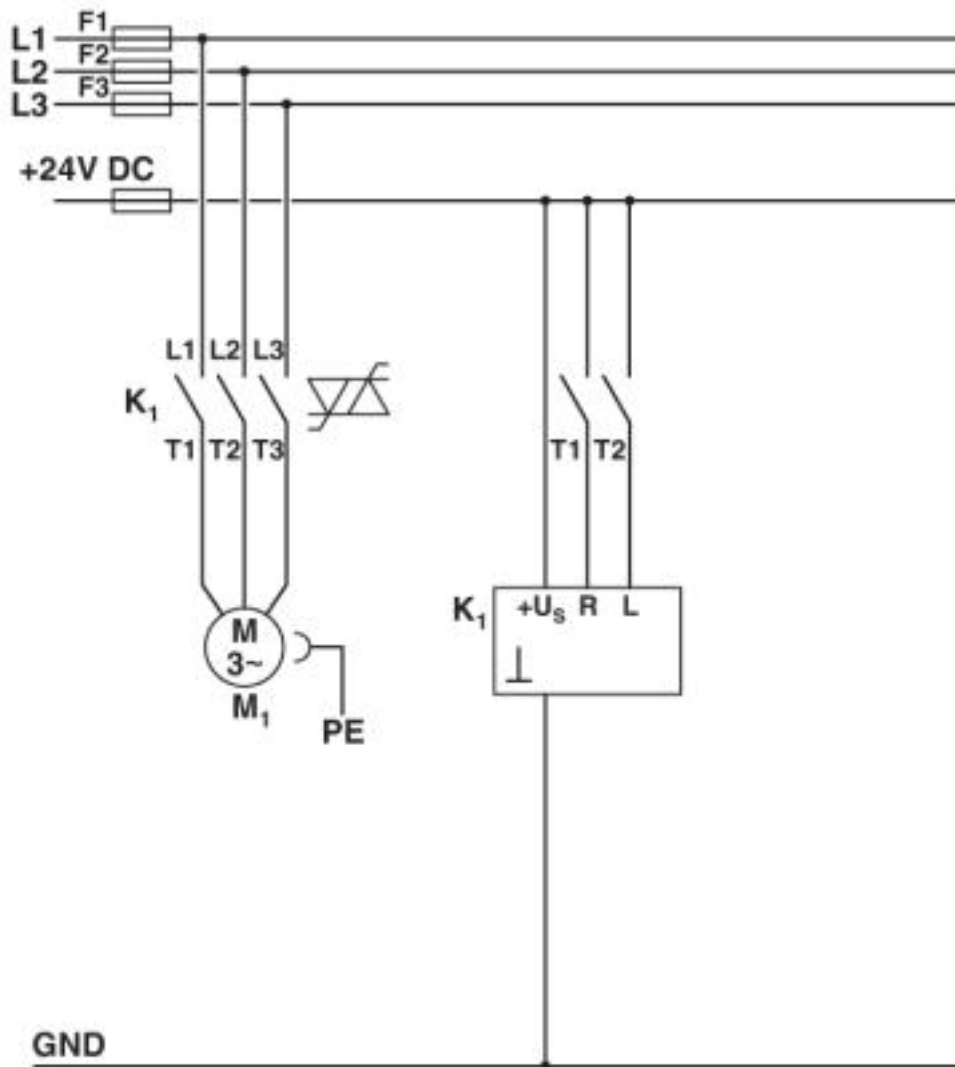

Structure with CONTACTRON
 Main and control current path for '3 in 1' hybrid motor starter
 K1 = '3 in 1' hybrid motor starter
 T1 = Right, T2 = Left

Hybrid motor starter - ELR H5-I-SC-230AC/500AC-9 - 2900578

Circuit diagram

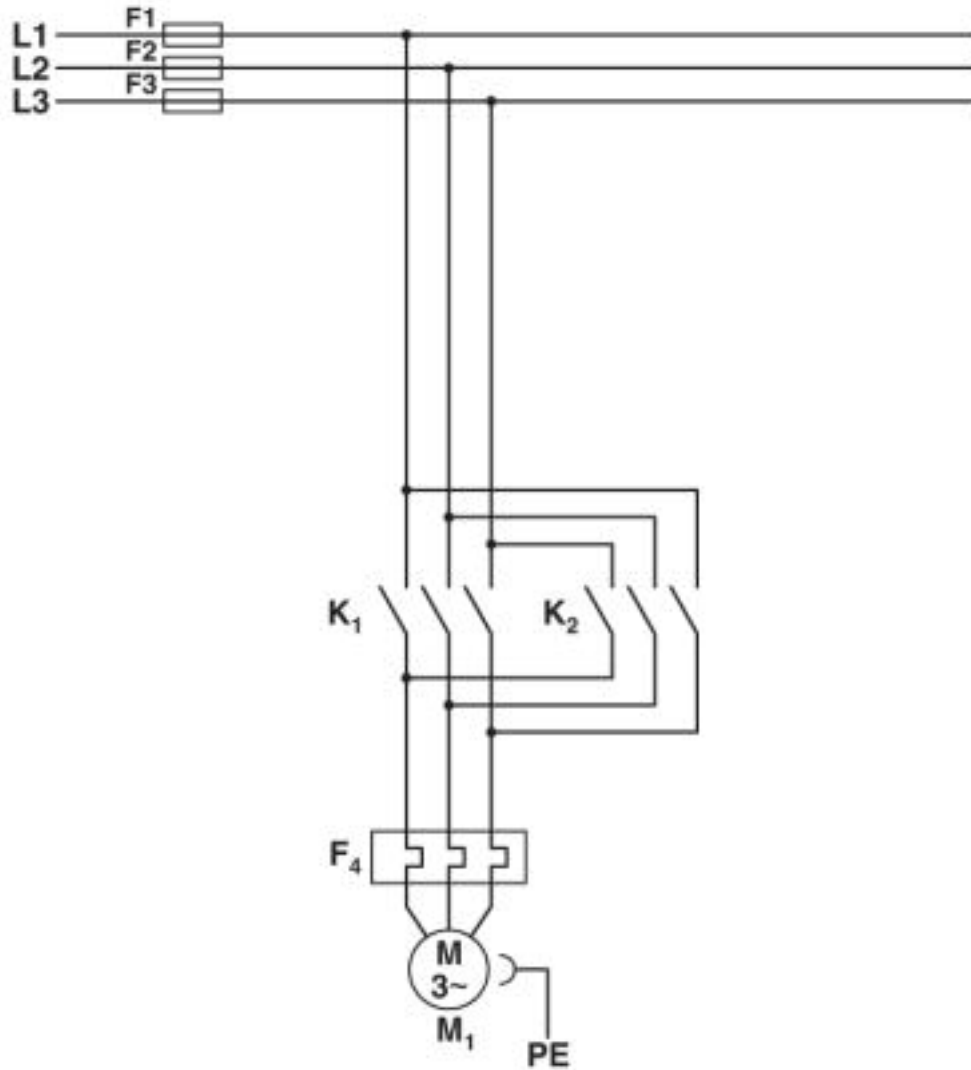

Conventional structure
 Main current path contactor
 K1 = Left contactor
 K2 = Right contactor
 F4 = Motor protection relay

Hybrid motor starter - ELR H5-I-SC-230AC/500AC-9 - 2900578

Block diagram

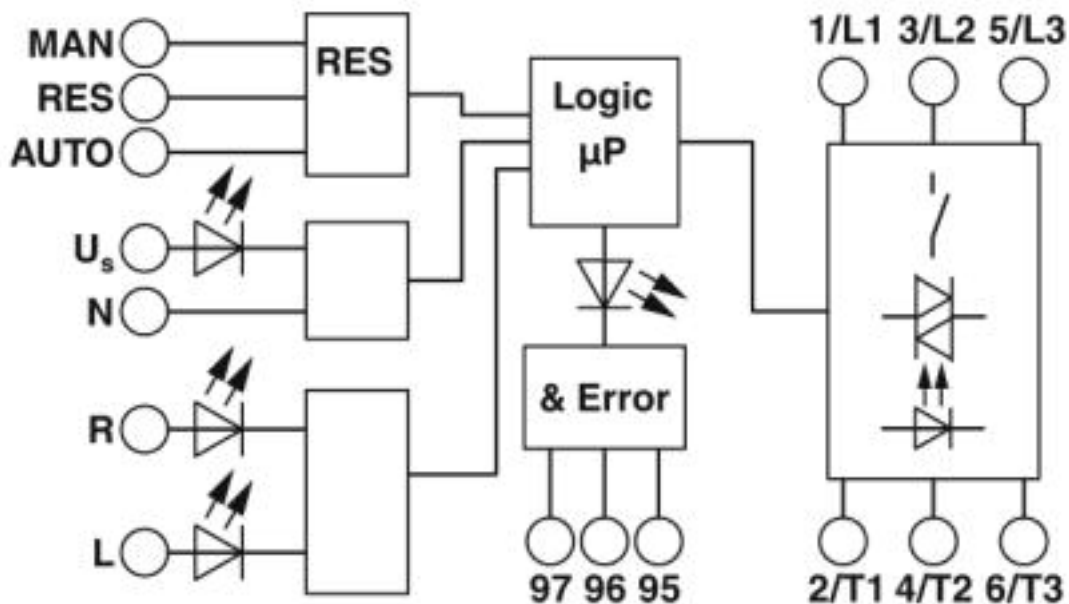

Diagram

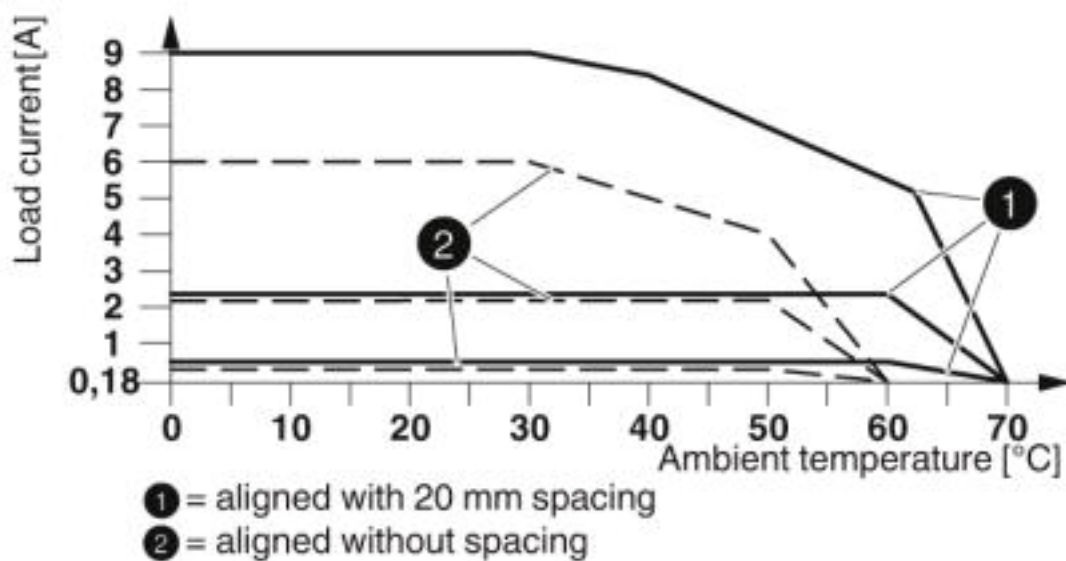

Derating diagram

Classifications

eCl@ss

eCl@ss 4.0	27021100
eCl@ss 4.1	27021100
eCl@ss 5.0	27024000
eCl@ss 5.1	27024000

<https://www.phoenixcontact.com/gb/products/2900578>



Hybrid motor starter - ELR H5-I-SC-230AC/500AC-9 - 2900578

Classifications

eCl@ss

eCl@ss 6.0	27024000
eCl@ss 7.0	27024002
eCl@ss 8.0	27024002
eCl@ss 9.0	27370905

ETIM

ETIM 2.0	EC001037
ETIM 3.0	EC001037
ETIM 4.0	EC001037
ETIM 5.0	EC001037
ETIM 6.0	EC001037
ETIM 7.0	EC001037

UNSPSC

UNSPSC 6.01	30211915
UNSPSC 7.0901	39121514
UNSPSC 11	39121514
UNSPSC 12.01	39121514
UNSPSC 13.2	25173902

Approvals

Approvals

Approvals

UL Listed / cUL Listed / UL Listed / IECCE CB Scheme / cUL Listed / CCC / EAC

Ex Approvals

ATEX

Approval details

UL Listed		http://database.ul.com/cgi-bin/XYV/template/LISEXT/1FRAME/index.htm	FILE E 228652
-----------	---	---	---------------

cUL Listed		http://database.ul.com/cgi-bin/XYV/template/LISEXT/1FRAME/index.htm	FILE E 228652
------------	---	---	---------------

Hybrid motor starter - ELR H5-I-SC-230AC/500AC-9 - 2900578

Approvals

UL Listed		http://database.ul.com/cgi-bin/XYV/template/LISEXT/1FRAME/index.htm	FILE E 323771
-----------	---	---	---------------

IECEE CB Scheme		http://www.iecee.org/	DE1-55728
-----------------	---	---	-----------

cUL Listed		http://database.ul.com/cgi-bin/XYV/template/LISEXT/1FRAME/index.htm	FILE E 323771
------------	---	---	---------------

CCC			2016010304871315
-----	---	--	------------------

EAC			RU C- DE.A*30.B.01082
-----	---	--	--------------------------



SCATTERGOOD & JOHNSON LTD

ELECTRICAL ENGINEERING & FLUID CONTROL DISTRIBUTORS

Est.1899

At Scattergood & Johnson Ltd, we pride ourselves on being a technical distributor to specialist industries.

Working with a range of quality product suppliers across a number of specialist markets, we are not your average 'box shifter' - we are your technical and supply chain partner.

We fully support every product we sell - for free! Our internal team and external sales engineers can answer any product or application question, no matter the complexity.

Backing up this technical ability is a range of 50,000+ products available from stock for nationwide next day delivery (same day if required!), or you can collect what you need from any of our trade counters around the UK.

Select your specialist interest below to learn more about how we can help.



Online, In Branch and On the Road - Scattergood & Johnson Ltd, there when you need us.

www.scatts.co.uk