

## **IFS system**

- Motor management
- Gateways
- Hybrid motor starter

User manual

## User manual

### IFS system

- Motor management
- Gateways
- Hybrid motor starter

2015-06-11

Designation: UM EN IFS system

Revision: 02

This user manual is valid for:

Designation	Order No.
EMM 3- 24DC/500AC-IFS	2297497
EMM 3-230AC/500AC-IFS	2297507
EMM 3- 24DC/500AC-16-IFS	2297523
EMM 3-230AC/500AC-16-IFS	2297536
EM-PB-GATEWAY-IFS	2297620
EM-CAN-GATEWAY-IFS	2901504
EM-MODBUS-GATEWAY-IFS	2901528
EM-DNET-GATEWAY-IFS	2901529
EM-RS232-GATEWAY-IFS	2901526
EM-RS485-GATEWAY-IFS	2901527
EM-ETH-GATEWAY-IFS	2901988
EM-PNET-GATEWAY-IFS	2904472
IB IL IFS-MA-PAC	2692720
IFS-USB-PROG-ADAPTER	2811271
IFS-CONFSTICK	2986122
IFS-CONFSTICK-L	2901103
UT 4-MTD-R/CVC 690/SET	2901667
CONTACTRON-DTM-IFS	2297727

---

## Please observe the following notes

### User group of this manual

The use of products described in this manual is oriented exclusively to:

- Qualified electricians or persons instructed by them, who are familiar with applicable standards and other regulations regarding electrical engineering and, in particular, the relevant safety concepts.
- Qualified application programmers and software engineers, who are familiar with the safety concepts of automation technology and applicable standards.

### Explanation of symbols used and signal words



This is the safety alert symbol. It is used to alert you to potential personal injury hazards. Obey all safety measures that follow this symbol to avoid possible injury or death.

There are three different categories of personal injury that are indicated with a signal word.

**DANGER** This indicates a hazardous situation which, if not avoided, will result in death or serious injury.

**WARNING** This indicates a hazardous situation which, if not avoided, could result in death or serious injury.

**CAUTION** This indicates a hazardous situation which, if not avoided, could result in minor or moderate injury.



This symbol together with the signal word **NOTE** and the accompanying text alert the reader to a situation which may cause damage or malfunction to the device, hardware/software, or surrounding property.



This symbol and the accompanying text provide the reader with additional information or refer to detailed sources of information.

### How to contact us

#### Internet

Up-to-date information on Phoenix Contact products and our Terms and Conditions can be found on the Internet at:

[phoenixcontact.com](http://phoenixcontact.com)

Make sure you always use the latest documentation.

It can be downloaded at:

[phoenixcontact.net/products](http://phoenixcontact.net/products)

#### Subsidiaries

If there are any problems that cannot be solved using the documentation, please contact your Phoenix Contact subsidiary.

Subsidiary contact information is available at [phoenixcontact.com](http://phoenixcontact.com).

#### Published by

PHOENIX CONTACT GmbH & Co. KG  
Flachsmarktstraße 8  
32825 Blomberg  
GERMANY

Should you have any suggestions or recommendations for improvement of the contents and layout of our manuals, please send your comments to:

[tecdoc@phoenixcontact.com](mailto:tecdoc@phoenixcontact.com)

**Please observe the following notes**

---

**General terms and conditions of use for technical documentation**

Phoenix Contact reserves the right to alter, correct, and/or improve the technical documentation and the products described in the technical documentation at its own discretion and without giving prior notice, insofar as this is reasonable for the user. The same applies to any technical changes that serve the purpose of technical progress.

The receipt of technical documentation (in particular user documentation) does not constitute any further duty on the part of Phoenix Contact to furnish information on modifications to products and/or technical documentation. You are responsible to verify the suitability and intended use of the products in your specific application, in particular with regard to observing the applicable standards and regulations. All information made available in the technical data is supplied without any accompanying guarantee, whether expressly mentioned, implied or tacitly assumed.

In general, the provisions of the current standard Terms and Conditions of Phoenix Contact apply exclusively, in particular as concerns any warranty liability.

This manual, including all illustrations contained herein, is copyright protected. Any changes to the contents or the publication of extracts of this document is prohibited.

Phoenix Contact reserves the right to register its own intellectual property rights for the product identifications of Phoenix Contact products that are used here. Registration of such intellectual property rights by third parties is prohibited.

Other product identifications may be afforded legal protection, even where they may not be indicated as such.

# Table of contents

1	Introduction .....	13
1.1	Product overview .....	13
1.2	About this user manual .....	16
2	EMM 3-.../500AC...-IFS electronic motor management module .....	19
2.1	Safety regulations/installation notes .....	20
2.2	Connection notes .....	21
2.2.1	Startup .....	21
2.2.2	Mains connection and line protection .....	21
2.2.3	Thermistor input .....	22
2.2.4	Block diagram .....	22
2.2.5	TBUS DIN rail connector .....	22
2.2.6	Connection versions .....	23
2.3	Function.....	25
2.3.1	Status LEDs .....	25
2.3.2	Parameterization .....	27
2.4	Technical data .....	28
2.4.1	Derating curves .....	32
2.4.2	Tripping characteristics at 20°C .....	34
2.5	Safety functions.....	36
3	Configuration telegrams and measured values for gateways .....	39
3.1	Configuration telegrams .....	39
3.1.1	Digital input and output .....	39
3.1.2	Module status .....	40
3.1.3	Station status .....	41
3.1.4	EMM objects .....	44
3.2	Measured values - CONTACTRON motor manager EMM .....	48
3.2.1	Available measured values .....	49
4	INTERBUS module IB IL IFS-MA(-2MBD)-PAC .....	51
4.1	Ordering data .....	52
4.2	Technical data .....	52
4.3	Internal basic circuit diagram .....	55
4.4	Terminal point assignment of the Inline and COMBICON connectors .....	56
4.5	Diagnostic and status indicators.....	58
4.5.1	Local diagnostic and status indicators .....	58
4.5.2	Local diagnostic and status indicators when using a memory stick .....	59
4.6	Function identification.....	59
4.7	Setting the data width on the local bus with DIP switches.....	59
4.8	Connection example.....	62
4.9	Connection note .....	62

**CONTACTRON motor management**

4.10	Programming data/configuration data.....	63
4.10.1	Local bus (INTERBUS) .....	63
4.10.2	Other bus systems .....	63
4.11	Process data .....	63
4.12	Configuring/parameterizing the device .....	64
4.13	Programming interface (S-PORT) .....	64
4.14	S-PORT: Using the memory stick .....	64
4.14.1	Saving the device configuration .....	65
4.14.2	Loading or restoring the configuration data .....	65
4.15	DTM functions .....	66
<b>5</b>	<b>PROFIBUS bus coupler for INTERFACE system devices .....</b>	<b>67</b>
5.1	Definition of terms.....	69
5.2	Connection notes .....	70
5.2.1	Mains connection and line protection .....	70
5.2.2	Block diagram .....	70
5.2.3	TBUS DIN rail connector .....	70
5.2.4	Status LEDs .....	71
5.2.5	S-PORT handling .....	72
5.2.6	Setting the PROFIBUS address .....	72
5.2.7	Setting the INTERFACE system address .....	74
5.3	PROFIBUS telegrams.....	76
5.3.1	Structure of the parameterization telegram .....	76
5.3.2	Structure of the diagnostic telegram .....	78
5.4	Technical data .....	82
<b>6</b>	<b>CANopen bus coupler for INTERFACE system devices .....</b>	<b>83</b>
6.1	Safety notes .....	83
6.2	Short description .....	83
6.3	Block diagram .....	84
6.4	Operating elements .....	84
6.5	Connection notes .....	85
6.5.1	Mounting .....	85
6.5.2	Bus termination .....	86
6.6	LED status indicators.....	86
6.7	Setting and displaying the fieldbus address .....	88
6.8	Setting and displaying the transmission speed.....	89
6.9	Setting and displaying the INTERFACE system address.....	90
6.10	Technical data .....	91

<b>7</b>	<b>DeviceNet bus coupler for INTERFACE system devices .....</b>	<b>93</b>
7.1	Safety notes .....	93
7.2	Short description .....	93
7.3	Block diagram .....	94
7.4	Operating elements .....	94
7.5	Connection notes .....	95
7.5.1	Mounting .....	95
7.5.2	Bus termination .....	96
7.6	LED status indicators.....	96
7.7	Setting and displaying the fieldbus address .....	98
7.8	Setting and displaying the transmission speed.....	99
7.9	Setting and displaying the INTERFACE system address.....	100
7.10	Technical data .....	101
<b>8</b>	<b>RS-232 bus coupler for INTERFACE system devices .....</b>	<b>103</b>
8.1	Safety notes .....	103
8.2	Short description .....	103
8.3	Block diagram .....	104
8.4	Operating elements .....	104
8.5	Connection notes .....	105
8.5.1	Mounting .....	105
8.6	LED status indicators.....	106
8.7	Setting the fieldbus address .....	107
8.8	Setting and displaying the INTERFACE system address.....	107
8.9	Technical data .....	108
<b>9</b>	<b>RS-485 bus coupler for INTERFACE system devices .....</b>	<b>109</b>
9.1	Safety notes .....	109
9.2	Short Description.....	109
9.3	Block diagram .....	110
9.4	Operating elements .....	110
9.5	Connection notes .....	111
9.5.1	Mounting .....	111
9.5.2	Bus termination .....	112
9.6	LED status indicators.....	112
9.7	Setting and displaying the fieldbus address .....	113
9.8	Setting and displaying the INTERFACE system address.....	114
9.9	Technical data .....	115

**CONTACTRON motor management**

<b>10</b>	<b>Ethernet bus coupler for INTERFACE system devices .....</b>	<b>117</b>
10.1	Safety notes .....	117
10.2	Short description .....	117
10.3	Block diagram .....	118
10.4	Operating elements .....	118
10.5	Connection notes .....	119
10.5.1	Mounting .....	119
10.6	LED status indicators.....	120
10.7	Setting IP mode .....	122
10.8	Setting and displaying the INTERFACE system address.....	123
10.9	Technical data .....	124
<b>11</b>	<b>Modbus bus coupler for INTERFACE system devices .....</b>	<b>125</b>
11.1	Safety notes .....	125
11.2	Short description .....	125
11.3	Block diagram .....	126
11.4	Operating elements .....	126
11.5	Connection notes .....	127
11.5.1	Mounting .....	127
11.6	LED status indicators.....	128
11.7	Setting IP mode .....	129
11.8	Setting and displaying the INTERFACE system address.....	130
11.9	Supported Modbus function codes for connection to a controller .....	130
11.10	Technical data .....	131
<b>12</b>	<b>PROFINET bus coupler for INTERFACE system devices .....</b>	<b>133</b>
12.1	Safety notes .....	133
12.2	Short description .....	133
12.3	Block diagram .....	134
12.4	Operating elements .....	134
12.5	Connection notes .....	135
12.5.1	Mounting .....	135
12.6	LED status indicators.....	136
12.7	Setting and displaying the INTERFACE system address.....	137
12.8	Technical data .....	138
<b>13</b>	<b>IFS-CONFSTICK(-L) memory block .....</b>	<b>139</b>
13.1	Writing the device configuration to the IFS-CONFSTICK(-L) .....	139

**Table of contents**

13.2	Loading the device configuration on the EMM...IFS .....	140
13.2.1	Brand new device .....	140
13.2.2	Configured device .....	140
13.3	Technical data .....	141
<b>14</b>	<b>TBUS DIN rail connector .....</b>	<b>143</b>
14.1	Technical data .....	144
<b>15</b>	<b>Current transformer selection guide .....</b>	<b>145</b>
15.1	Three-phase motor at a rotational frequency of 3000 rpm .....	146
15.2	Three-phase motor at a rotational frequency of 1500 rpm .....	147
15.3	Three-phase motor at a rotational frequency of 1000 rpm .....	148
15.4	Three-phase motor at a rotational frequency of 750 rpm .....	149
15.5	Recommended restart time .....	150
<b>16</b>	<b>CONTACTRON-DTM-IFS device drivers .....</b>	<b>151</b>
16.1	System requirements.....	152
16.1.1	Supported operating systems .....	152
16.1.2	Hardware requirements .....	152
16.1.3	Software requirements .....	152
16.1.4	Programming adapters/cables .....	153
16.1.5	Configuration package .....	153
16.2	Connecting the programming adapter .....	153
16.2.1	Connection notes .....	154
16.2.2	Connection to the PC .....	154
16.2.3	Connection to the device .....	154
16.3	Software installation .....	155
16.3.1	Starting the application .....	156
16.4	Software configuration.....	156
16.4.1	Initial startup .....	156
16.4.2	Transferring CONTACTRON-DTM-IFS to catalog management .....	157
16.4.3	Topology scan .....	158
16.4.4	Connecting several devices via an IFS gateway .....	159
16.4.5	Functions .....	160
16.4.6	Options .....	162
16.5	Process data configuration .....	163
16.5.1	Definition of process data .....	164
16.5.2	Downloading process data .....	165
16.6	Monitoring dialog box .....	166
16.7	Settings .....	167
16.7.1	CAN gateway EM-CAN-GATEWAY-IFS .....	168
16.7.2	Ethernet gateway EM-ETH-GATEWAY-IFS .....	169

**CONTACTRON motor management**

16.7.3	RS-232 gateway EM-RS232-GATEWAY-IFS .....	173
16.7.4	RS-485 gateway EM-RS485-GATEWAY-IFS .....	174
16.7.5	PROFIBUS gateway EM-PB-GATEWAY-IFS .....	175
16.7.6	PROFINET gateway EM-PNET-GATEWAY-IFS .....	176
16.7.7	Modbus gateway EM-MBUS-GATEWAY-IFS .....	179
16.7.8	DeviceNet gateway EM-DNET-GATEWAY-IFS .....	183
16.8	Diagnostics dialog box .....	184
16.8.1	Overview .....	185
16.8.2	Diagnostics .....	186
16.9	Saving the project.....	187
16.10	EMM 3- xx/500AC/xx-IFS module parameter menu .....	188
16.10.1	User interface .....	188
16.10.2	Buttons in the IFS-Conf toolbar .....	189
16.10.3	Buttons in the DTM toolbar .....	190
16.10.4	Status bar .....	191
16.11	EMM 3- xx/500AC/xx-IFS module DTM.....	192
16.11.1	Settings .....	192
16.11.2	Online/offline parameters .....	215
16.11.3	Writing the configuration to the device .....	228
16.11.4	Monitoring dialog box .....	229
17	Integration in PC Worx with INTERBUS communication .....	239
17.1	System requirements.....	239
17.2	Installing the software and DTM libraries.....	239
17.3	Creating a project and integrating DTMs in PC Worx .....	241
17.4	Reading or inserting devices in the bus configuration.....	243
17.4.1	Reading in the local bus (IB IL IFS-MA-PAC) automatically .....	243
17.4.2	Inserting the IB IL IFS-MA-PAC manually .....	245
17.4.3	Inserting lower-level devices manually .....	246
17.5	Compiling the project and downloading it to the controller.....	247
17.6	Calling DTM functions .....	247
17.6.1	General DTM functions .....	247
17.6.2	DTM functions of the controller .....	248
17.6.3	DTM functions of the IB IL IFS-MA-PAC .....	249
17.7	DTM functions .....	249
17.7.1	Naming lower-level devices .....	249
17.7.2	Assigning process data .....	251
17.7.3	Downloading the parameters .....	252
17.7.4	Displaying, monitoring, specifying data of an EMM .....	253
18	Integration in STEP 7 with PROFIBUS communication .....	255
18.1	Flow chart.....	255
18.2	Downloading the GSD file.....	255

**Table of contents**

18.3	Integration in STEP 7 .....	256
18.3.1	Example with SIMATIC 300 .....	261
18.4	Setting the byte order .....	265
18.5	Explanation of GSD data .....	266
18.5.1	GSD data for EM-PB-GATEWAY-IFS .....	266
18.5.2	GSD data for EMM ... IFS .....	266
18.6	Example .....	268
18.6.1	Hardware structure .....	268
18.6.2	GSD values used .....	269
18.6.3	Monitoring variables .....	270
<b>19</b>	<b>Integration in CoDeSys with Modbus/TCP communication .....</b>	<b>273</b>
19.1	Flow chart .....	273
19.2	Integration in CoDeSys .....	274
19.3	I/O mapping .....	283
19.4	Example .....	286
<b>20</b>	<b>Integration in a CompactLogix controller from Allen-Bradley .....</b>	<b>289</b>
20.1	Integrating the EDS file .....	289
20.2	Creating a project .....	290
20.3	Integrating the EM-ETH-GATEWAY-IFS .....	291
<b>21</b>	<b>EM-MODBUS-GATEWAY-IFS used with the Phoenix Contact controllers .....</b>	<b>295</b>
21.1	System requirements .....	295
21.1.1	Software requirements .....	295
21.1.2	Hardware requirements for PC Worx .....	295
21.2	Modbus/TCP .....	295
21.3	Example of a project with Modbus .....	296
21.3.1	Sequence for creating the Modbus project .....	296
21.3.2	Creating a new project .....	298
21.3.3	Specifying project information .....	298
21.3.4	Checking/modifying IP settings for the controller .....	298
21.3.5	Inserting a Modbus device .....	299
21.3.6	Modifying the settings for the Modbus device .....	300
21.3.7	Compiling after completing the bus topology .....	301
21.3.8	Creating the program .....	301
21.3.9	Compiling after creating the program .....	301
21.3.10	Creating process data and assigning Modbus function codes .....	301
21.3.11	Generating variables and assigning process data .....	302
21.3.12	Generating diagnostic and control variables and assigning process data 303	
21.3.13	Compiling a project .....	304

## CONTACTRON motor management

---

21.3.14	Configuring the Modbus device .....	304
21.3.15	Sending a project and performing a cold restart .....	304
21.4	Acyclic communication using the MB_ASYNC_RW function block .....	305
21.4.1	Error codes of the "Status" output (Error = TRUE) .....	306
21.4.2	Using the server ID of the diagnostic variable .....	308
21.4.3	Specifying the size of the ReadBuffer/WriteBuffer .....	310
<b>22</b>	<b>Application examples .....</b>	<b>313</b>
22.1	Example 1 - Without switching function, with power meter monitoring.....	313
22.1.1	Hardware configuration .....	313
22.1.2	Software configuration .....	314
22.2	Example 2 - Direct starter for pump monitoring.....	315
22.2.1	Hardware configuration .....	315
22.2.2	Software configuration .....	316
22.3	Example 3 - Direct starter with current transformer.....	318
22.3.1	Hardware configuration .....	318
22.3.2	Software configuration .....	319
22.4	Example 4 - Reversing starter in potentially explosive areas (ATEX).....	321
22.4.1	Hardware configuration .....	321
22.4.2	Software configuration .....	322
22.5	Example 5 - Star/delta .....	324
22.5.1	Hardware configuration .....	324
22.5.2	Software configuration .....	325
22.6	Example 6 - Star/delta LR.....	326
22.6.1	Hardware configuration .....	326
22.6.2	Software configuration .....	327
22.7	Example 7 - Reversing starter with connection to PROFIBUS.....	328
22.7.1	Hardware configuration .....	328
22.7.2	Software configuration .....	329
22.8	Example 8 - 690 V reversing starter with voltage transducer .....	330
22.8.1	Hardware configuration .....	330
22.8.2	Software configuration .....	331

# 1 Introduction

## 1.1 Product overview

Electronic motor management modules (EMMs) (for order numbers, see “Technical data” on page 28) offer all the advantages of modern real power monitoring. Every 6.6 ms, the real power consumed of a drive system or another 3-phase load is determined based on three currents, voltages, and the phase angle.

EMM 3-.../500AC-16-IFS modules can measure currents of up to 16 A via integrated converters. EMM 3-.../500AC-IFS modules require additional external converters.

The actual switching of the load is performed by a separate switching element. The EMM is designed to reliably protect connected loads - irrespective of their rated power - against overload and underload, and to provide continuous status monitoring.

Freely parameterizable switching and signaling thresholds, plus four configurable digital outputs enable not only motor protection, but also protection for units or mechanical elements connected downstream, in particular.

All the relevant values are available via configuration software or a fieldbus interface: apparent, real, and reactive power, currents and voltages, phase angle, operating cycle and operating hours counters, power meter.

The EMM modules can monitor up to eight measured values simultaneously and control the four digital outputs according to the parameterization.

### Power within limits

Monitoring is by means of freely parameterizable switching and signaling thresholds for overload and underload detection. By default, the thresholds are the same for both directions of rotation or are set separately for right/left rotation.

The value used as the basis for parameterization is the consumed real power, which is independent of voltage fluctuations and the drive machine load, and therefore much more precise than merely taking the current into consideration. If a switching threshold is violated, the EMM initiates an emergency shutdown of the motor immediately (or with an adjustable “delay time”). In addition, a message, e.g., to a higher-level controller, is sent via an output.

This state can only be deactivated by means of a defined reset. If the real power consumed is determined to be above or below the signaling threshold, only one confirmation is sent during the period that the module is controlled.

In addition, the module generates signals to detect the direction of rotation. Phase failures are detected and signaled.

Continuous status monitoring with high scanning rates enables complete system protection, including motor protection.

## CONTACTRON motor management

The right rotation, left rotation, reverse, and limit switch operation (with integrated restart inhibit) modes switch actuating and regulating drives, pumps, tools, conveyor belts or similar, and monitor function, contamination or wear. The adjustable “inrush suppression” time can be used to mask out the switching operation from the monitoring process.

Tooling machines are monitored and protected in a similar way when drilling, milling or grinding. If the feed value set on a milling machine is too high, the worst-case scenario is that a tool may break. The power threshold parameterized accordingly remedies this matter. A signaling threshold also signals tool wear in advance.

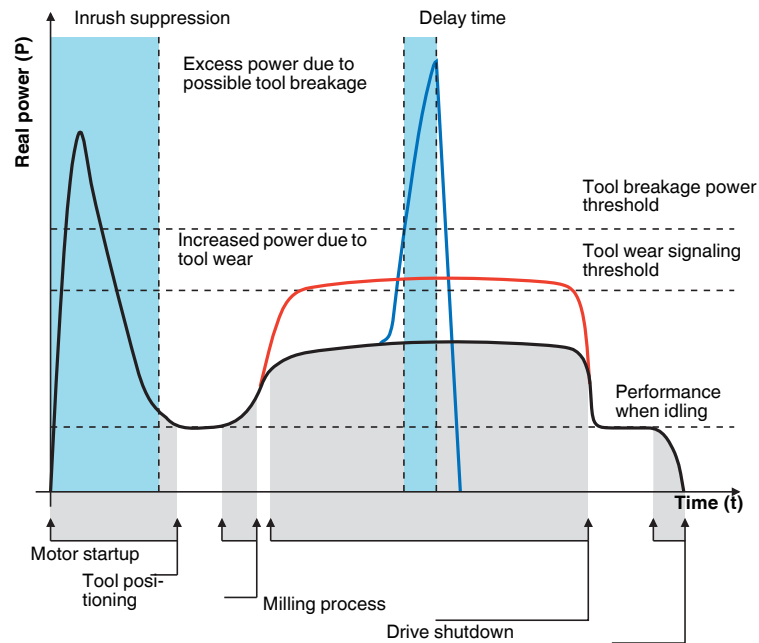

Figure 1-1 Example of broken tool

In the case of motor-driven pumps, the lower power threshold provides reliable protection against hazardous dry running. Forced shutdown of the drive can be delayed by the “delay time”. This prevents a response to any air bubbles that may be present in the system. Fans are monitored for broken V-belts in the same way.

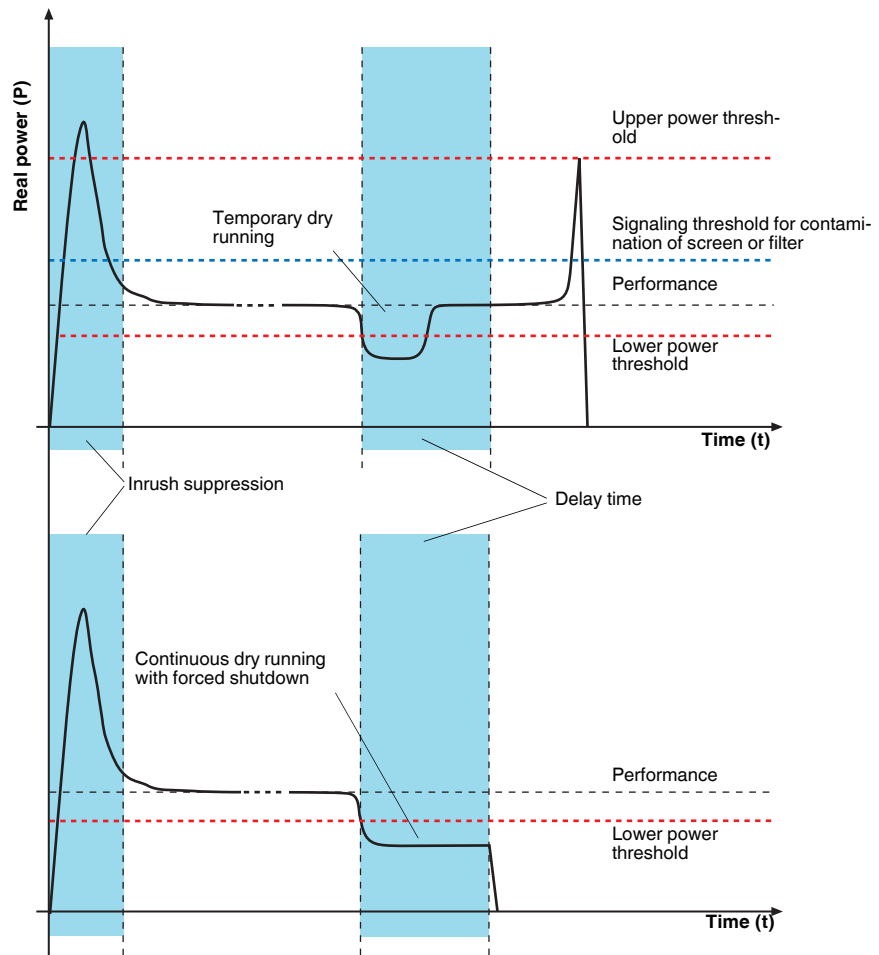

Figure 1-2 Example of dry running

## 1.2 About this user manual

This manual contains comprehensive information about the electronic CONTACTRON motor management modules and devices that are required in order to successfully use the modules. Detailed descriptions are provided for the following topics:

Contents	Section
Function and handling of the electronic motor management modules	Section "EMM 3-.../500AC...-IFS electronic motor management module" on page 19
Configuration telegrams and measured values for gateways	Section "Configuration telegrams and measured values for gateways" on page 39
Terminals for connecting INTERFACE modules to the Inline system via the INTERFACE system bus	Section "INTERBUS module IB IL IFS-MA(-2MBD)-PAC" on page 51
Function and handling of the PROFIBUS gateway	Section "PROFIBUS bus coupler for INTERFACE system devices" on page 67
Function and handling of the CANopen gateway	Section "CANopen bus coupler for INTERFACE system devices" on page 83
Function and handling of the DeviceNet gateway	Section "DeviceNet bus coupler for INTERFACE system devices" on page 93
Function and handling of the RS-232 gateway	Section "RS-232 bus coupler for INTERFACE system devices" on page 103
Function and handling of the RS-485 gateway	Section "RS-485 bus coupler for INTERFACE system devices" on page 109
Function and handling of the Ethernet gateway	Section "Ethernet bus coupler for INTERFACE system devices" on page 117
Function and handling of the Modbus/TCP gateway	Section "Modbus bus coupler for INTERFACE system devices" on page 125
Function and handling of the PROFINET gateway	Section "PROFINET bus coupler for INTERFACE system devices" on page 133
Handling of the memory block for easy storage and backup of configuration data	Section "IFS-CONFSTICK(-L) memory block" on page 139
Installation of the modules on a DIN rail	Section "TBUS DIN rail connector" on page 143
Selection of a suitable current transformer for the electronic motor management modules	Section "Current transformer selection guide" on page 145

<b>Contents [...]</b>	<b>Section</b>
Description of the software for parameterizing the electronic motor management modules and gateways	Section "CONTACTRON-DTM-IFS device drivers" on page 151
Integration of EMM modules in PC Worx	Section "Integration in PC Worx with INTERBUS communication" on page 239
Integration of EMM modules in STEP 7	Section "Integration in STEP 7 with PROFIBUS communication" on page 255
Integration of EMM modules in CoDeSys	Section "Integration in CoDeSys with Modbus/TCP communication" on page 273
Integration of EM-ETHGATEWAY-IFS in a CompactLogix controller from Allen-Bradley	Section "Integration in a Compact-Logix controller from Allen-Bradley" on page 289
Implementation and startup of the EM-MOD-BUS-GATEWAY-IFS on the Phoenix Contact controllers	Section "EM-MODBUS-GATEWAY-IFS used with the Phoenix Contact controllers" on page 295
Application examples for the products described here	Section "Application examples" on page 313

## CONTACTRON motor management

---

## 2 EMM 3-.../500AC...-IFS electronic motor management module

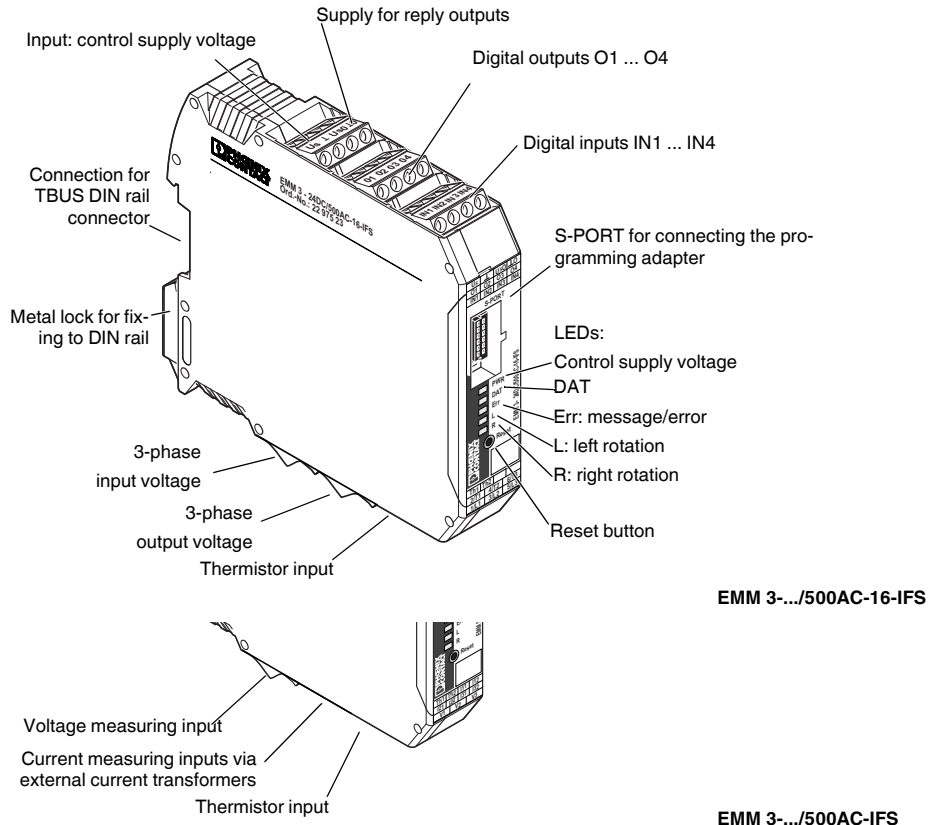

Figure 2-1 EMM 3-.../500AC...-IFS

## 2.1 Safety regulations/installation notes



### **WARNING: Risk of injury**

During operation, parts of electrical switching devices carry hazardous voltages.

Before working on the device, disconnect the power.

Disregarding these safety regulations may result in death, serious personal injury or damage to equipment.

When working on the device, observe the national safety and accident prevention regulations.

Startup, mounting, modifications, and upgrades may only be carried out by a skilled electrical engineer.

The installation has to be performed in accordance with the instructions in the operating manual. Access to circuits within the device is not permitted.

Protective covers must not be removed.

When using devices with 230 V AC control, always use the same phase for the rated control supply voltage and the control inputs.



### **NOTE: Possible damage to the device**

The device is associated equipment and may not be installed in potentially explosive areas. When installing and operating associated equipment, the applicable safety directives must be observed.

The equipment may not be exposed to mechanical or thermal influences that exceed the limits as described in the operating instructions. In order to provide protection against mechanical or electrical damage, install the device in an appropriate housing with a suitable degree of protection according to IEC 60529/EN 60529. Where dust is present, the device must be installed in suitable housing (IP64, minimum) according to EN 61241.

The equipment cannot be repaired by the user and must be replaced by an equivalent device. Repairs may only be carried out by the manufacturer.



Keep the instructions in a safe place.

The device performs diagnostics of the functions when the drive is switched on or has been switched off. In addition, an electrically skilled person or another skilled worker who is familiar with the relevant standards can carry out the "motor protection" safety function test. For this test, the drive must be operated with left or right rotation and the current flow in a conductor must be interrupted (e.g., by removing a fuse in phase L1 or L3). The EMM then shuts down the digital outputs within a period of 1.5 ... 2 s, depending on the parameterization. The LEDs for left or right rotation go out and the ERR LED flashes. When thermistor monitoring is used, this function can be checked by interrupting the thermistor cable once and short circuiting it once.

### **Scope of use**

- The EMM 3-230AC... is a product designed for environment A (industrial applications). In environment B (domestic applications), this device can cause undesirable radio interference; in such a case, the user may be required to implement appropriate measures.
- The EMM 3- 24DC... can also be used in environment B (domestic applications).

## 2.2 Connection notes

### 2.2.1 Startup



A brand new device must be parameterized prior to startup. Otherwise operation is not possible.

In order to prevent parameters from being changed during operation, the software can only be used when the device is not activated.

Table 2-1 Requirements

Product	Order No.
CONTACTRON-DTM-IFS software for device parameterization of the electronic motor management modules (EMMs) See Section "CONTACTRON-DTM-IFS device drivers" on page 151	2297727
IFS-USB-PROG-ADAPTER programming adapter for configuring Phoenix Contact INTERFACE system modules with 12-pos. S-PORT interface IFS-USB-DATACABLE See Section "Connecting the programming adapter" on page 153	2811271 2320500
IFS-CONFSTICK or IFS-CONFSTICK-L for easy storage and backup of configuration data See Section "IFS-CONFSTICK(-L) memory block" on page 139	2986122 2901103

### 2.2.2 Mains connection and line protection



**WARNING: Risk of electric shock**

Never carry out work when voltage is present!

When connecting the 3-phase network, it is essential to observe the terminal identification.

Protection	
IEC: 25 A (diazed)	Line protection for maximum cable cross section of 2.5 mm <sup>2</sup>
UL: 25 A (0.81" x 5")	LPS-RK-25-SP line protection, RK1 AWG 12

The control supply voltage inputs and control voltage inputs must be operated with power supply modules according to DIN 19240 (maximum residual ripple of 5%).



**NOTE: Observe air clearances and creepage distances**

When using devices with 230 V AC control, always use the same phase for the control supply voltage and the control inputs.

In order to avoid inductive or capacitive coupling of disturbing pulses where long control lines are used, we recommend using shielded cables.



**NOTE: Electrical safety**

Only connect conductors with the same conductor cross section to a terminal point.

## CONTACTRON motor management

If you wish to monitor a 690 V network with EMM 3-.../500AC-IFS devices, the UT 4-MTDR/CVC 690/SET voltage transducer (Order No. 2901667) must be used.

### 2.2.3 Thermistor input

In order to protect the motor against overheating, 1 to 6 PTC thermistors can be connected in series via terminal points “Th1” and “Th2”.

Cable lengths between EMM and thermistor in [m]	35	70	100	140	210	355
Conductor cross section [mm <sup>2</sup> ]	0.25	0.5	0.75	1	1.5	2.5

### 2.2.4 Block diagram

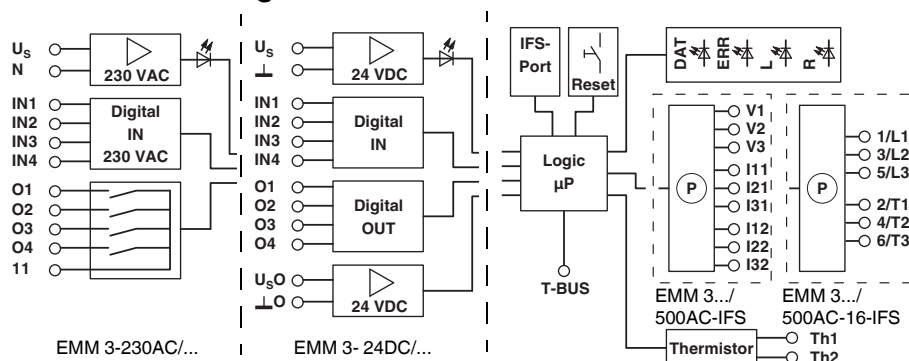

Figure 2-2 Block diagram

### 2.2.5 TBUS DIN rail connector



The TBUS DIN rail connector can only be used to supply the modules if 24 V DC devices are used.

The EMM 3-.../500AC...-IFS modules can be mounted on a DIN rail. For detailed information about mounting/removal, please refer to Section “TBUS DIN rail connector” on page 143.

## EMM 3-.../500AC...-IFS electronic motor management module

### 2.2.6 Connection versions

#### 2.2.6.1 Separate switching element

Depending on the requirements of the application, either an electromechanical contactor or reversing contactor combination, or an electronic load relay or reversing load relay should be used to switch the load.

To control these switching elements, the EMM supplies four digital outputs:

- EMM 3- 24DC/...      Semiconductor outputs with 24 V DC/500 mA
  - EMM 3-230AC/...      Floating relay outputs with 230 V AC/500 mA
- For inductive loads, use a suitable contact protection circuit.

#### 2.2.6.2 Line currents up to 16 A

For line currents up to 16 A, EMM 3-.../500AC-16-IFS modules are suitable thanks to their integrated current transformers up to 16 A.

The external switching element is controlled directly via the EMM.

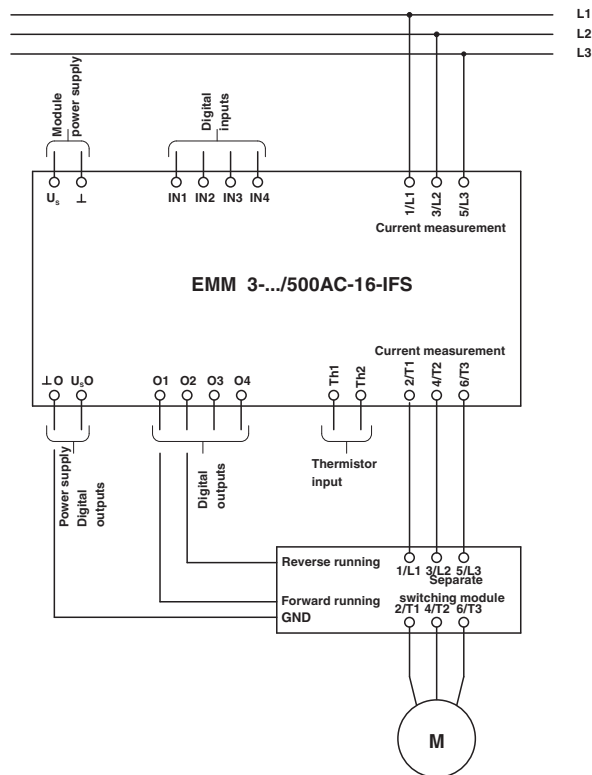

Figure 2-3 EMM 3-.../500AC-16-IFS for line currents up to 16 A

## CONTACTRON motor management

### 2.2.6.3 Line currents >16 A - External current transformers

For currents >16 A, use EMM 3-.../500AC-IFS modules. These require additional external current transformers.

Appropriate PACT Analog current transformers can be found in the Phoenix Contact INTERFACE catalog. The basic insulation requirements are met by PACT current transformers. A selection guide can be found in Section 15 on page 145.



**WARNING: Risk of electric shock**

Current transformers and the measuring instruments to be connected to them must only be installed when the system power is switched off.

During wiring, observe the order in which the current transformers are connected (direction of current flow).

Primary circuit: K-P1 → L-P2; secondary circuit: k-S1 → I-S2



**WARNING: Risk of electric shock**

When the current transformer is operated with an open secondary circuit, hazardous voltages may occur at the secondary terminal blocks.

Table 2-2 Recommended transformer data

Requirement	Value
Impulse withstand voltage	6 kV
Primary voltage	1000 V
Overvoltage category	III
Standard	EN 50178, IEC 60044-1
Transformer type	Linear measuring transducer
Temperature range	-25°C ...+70°C
Transformation ratio	$TR = \frac{I_{pn}}{I_{sn}}$
Primary rated current $I_{pn}$	Application-specific
Secondary rated current $I_{sn}$	5 A
EMM internal resistance	0.02 Ω
Error, system, sum	EMM errors + Transformer errors
Transformer class	1

Maximum cable length [m] between EMM and external current transformer (depending on the rated power  $S_n$  of the current transformer and the conductor cross section used):

Conductor cross section	Rated power $S_n$ [VA]											
	1.25	1.5	2	2.5	3.75	5	7.5	10	15	20	30	45
0.75 mm <sup>2</sup>	0.5	0.6	1.0	1.4	2.2	3.0	4.7	6.5	9.8	13.3	20.0	30.4
1 mm <sup>2</sup>	0.6	0.9	1.4	1.8	3.0	4.1	6.3	8.6	13.2	17.8	26.9	40.6
1.5 mm <sup>2</sup>	1.0	1.4	2.0	2.7	4.4	6.1	9.5	13.0	19.8	26.6	40.3	60.8
2.5 mm <sup>2</sup>	1.7	2.2	3.4	4.6	7.4	10.2	15.9	21.6	33.0	44.4	67.2	101.4

**EMM 3-.../500AC...-IFS electronic motor management module**

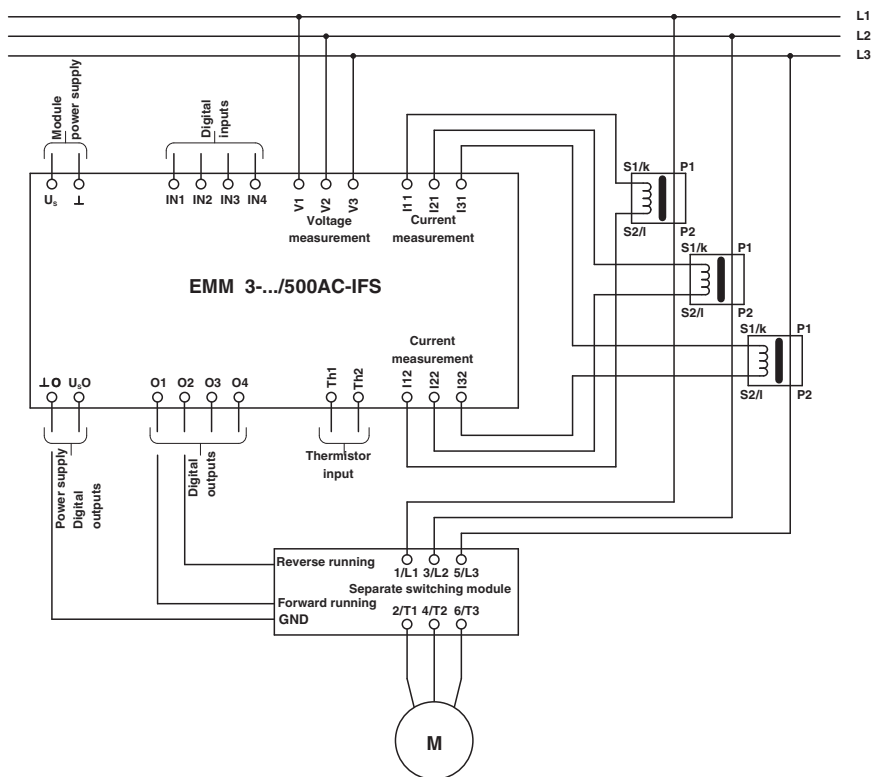

Figure 2-4 EMM 3-.../500AC-IFS for currents >16 A

## 2.3 Function

### 2.3.1 Status LEDs

The EMM visualizes the operating states using a total of five (5) LEDs. The functions of the LEDs are based on NAMUR recommendation NE 44.

When the rated control supply voltage is applied, all LEDs light up once as an LED test.

A green LED (PWR) indicates the general device status.

Left or right rotation of the drive is indicated by one yellow LED each (L/R).

An internal or external error (process error: overcurrent, asymmetry, phase failure) is indicated by a red LED (ERR). The device then enters the safe shutdown state. To exit this state (external error), error acknowledgment is required.



All internal errors cannot be acknowledged and are stored in the Flash memory.

## CONTACTRON motor management

LED					Reason
PWR	DAT	ERR	L	R	
O	x	x	x	x	No supply voltage (control supply voltage) present
E	x	x	x	x	Supply voltage (control supply voltage) present
E	x	A	E	A	Drive switched on: left rotation (L)
E	x	A	A	E	Drive switched on: right rotation (R)
E	x	A	B	B	A message is present.
E	E	x	x	x	Cyclic data traffic
E	x	E	x	x	Internal device error. Acknowledgment not possible. Module faulty.
E	x	B	A	A	External error in control or I/O. (Maintenance required, NE44, see "Error acknowledgment")
E	x	B	B	B	Error when restoring the system state. The thermal memory of the bimetal function is set to the maximum value.
E	x	B	E	A	Bimetal trigger. Cooling time running. Acknowledgment not possible.
E	x	B	A	E	- An error occurred during left rotation
E	x	B	A	E	- An error occurred during right rotation
E	x	B	E	B	Bimetal trigger. Cooling time has elapsed. Acknowledgment possible.
E	x	B	E	B	- An error occurred during left rotation
E	x	B	A	B	- An error occurred during right rotation

A: Off                      B: Flashing  
E: On                        x: Off or on

### Error acknowledgment

There are various options available for error acknowledgment:

Type of acknowledgment	Description
Manual (reset button)	An acknowledgment is triggered by pressing the reset button on the front of the device. If the reset button is held down for more than approximately 2 seconds, the EMM will enter the error state again.
Manual (remote acknowledgment)	A remote acknowledgment operating point can be implemented by connecting a button (N/O contact) to IN 4. An acknowledgment is triggered as soon as a positive edge is detected at the input. If no negative edge is detected after approximately 2 seconds, the EMM enters the error state again since manipulation or a fault in the acknowledgment circuit may have occurred.
Manual (software)	An acknowledgment can be implemented by the operating software.
Automatic	For certain errors, an automatic acknowledgment can be parameterized.

### Feedback

All unused outputs of the EMM are available for feedback. The behavior of the reply outputs is specified by the parameterization.

## EMM 3-.../500AC...-IFS electronic motor management module

### 2.3.2 Parameterization

The CONTACTRON-DTM-IFS configuration software provided is required in order to parameterize and visualize the EMM (for detailed information, please refer to Section 16 on page 151). In addition, the IFS-USB-PROG-ADAPTER USB programming adapter (Order No. 2811271), the IFS-USB-DATACABLE programming cable (Order No. 2320500, for devices with USB interface) or the RJ45 network cable (for devices with RJ45 interface) are also required (for detailed information, please refer to Section 16.2 on page 153).

The configuration software is used to:

- Display and record operating data so that this can be further processed, e.g., in databases.
- Define switching output types, such as:  
Digital outputs without switching function, direct starters, reversing starters, star/delta starters, star/delta L/R.

Inputs IN1 to IN3 are specifically assigned to the functions (motor function or digital output). Input IN4 is assigned to the remote reset.

Table 2-3 Configuration, settings: switching output, static inputs

Switching output type	Input/output	Description
Digital outputs	Inputs IN1 ... IN3	No function (logical operation on request)
	Input IN4	Reset
	Outputs O1 ... O4	Freely parameterizable
Direct starter	Input IN1	Start/stop
	Input IN2	No function (logical operation on request)
	Input IN3	On-site control
	Input IN4	Reset
	Output O1	Contactors start/stop
	Outputs O2 ... O4	Freely parameterizable
Reversing starter	Input IN1	Right rotation
	Input IN2	Left rotation
	Input IN3	On-site control
	Input IN4	Reset
	Output O1	Right contactor
	Output O2	Left contactor
	Outputs O3 ... O4	Freely parameterizable
Star/delta	Input IN1	Start/stop
	Input IN2	No function (logical operation on request)
	Input IN3	On-site control
	Input IN4	Reset
	Output O1	Mains contactor
	Output O2	Delta contactor
	Output O3	Star contactor
	Output O4	Freely parameterizable

## CONTACTRON motor management

Table 2-3 Configuration, settings: switching output, static inputs [...]

Switching output type	Input/output	Description
Star/delta L/R	Input IN1	Right rotation
	Input IN2	Left rotation
	Input IN3	On-site control
	Input IN4	Reset
	Output O1	Mains contactor (right)
	Output O2	Mains contactor (left)
	Output O3	Delta contactor
	Output O4	Star contactor

## 2.4 Technical data

The technical data applies for the following products.

Product	Order No.
EMM 3- 24DC/500AC-IFS	2297497
EMM 3- 24DC/500AC-16-IFS	2297523
EMM 3-230AC/500AC-IFS	2297507
EMM 3-230AC/500AC-16-IFS	2297536

Input data	EMM 3- 24DC/...	EMM 3-230AC/...
Rated control supply voltage $U_s$ according to IEC 60947-1/ UL 508 / UL 60947-4-1(A) / UL 60947-1(A)	24 V DC	230 V AC
Control supply voltage range	19.2 ... 30 V DC	96 ... 253 V AC
Current consumption at $U_s$	≤33 mA	≤12 mA
Rated frequency	-	50 ... 60 Hz
Control inputs IN1 - IN4:		
Switching level "High"	19.2 V DC	96 V AC
Switching level "Low"	9.6 V DC	48 V AC
Input current	3.3 mA	3.5 mA
Input circuit	Serial diode for protection against polarity reversal	-
Control supply voltage indicator		Green PWR LED
Status indicator		Yellow L, R LED
Data communication		Green DAT LED
Error indication		Red ERR LED

## EMM 3-.../500AC...-IFS electronic motor management module

	EMM 3- 24DC/...	EMM 3-230AC/...
Thermistor input	1 ... 6 thermistors in series (PTC) For ATEX applications 3 ... 6 thermistors	
Total cold resistance	≤1.5 kΩ	
Operate value	≥3.72 kΩ	
Release value	≤1.61 kΩ	
Open circuit	≥60 kΩ	
Short circuit	≤20 Ω	



Reply output	EMM 3- 24DC/...	EMM 3-230AC/...	
Feedback O1 ... O4	Semiconductor (short-circuit-proof)	Relay (N/O contact)	
Contact type	-	4 x single contact	
Contact material	-	Ag alloy, hard gold-plated	
When used as	-	<b>Signal contact</b>	<b>Power contact</b>
Nominal output voltage $U_{SO}$	24 V DC	24 V AC/DC	230 V AC
Maximum switching voltage	30 V DC	30 V AC/36 V DC	250 V AC/DC
Min. switching voltage	19.2 V DC	0.1 V AC/DC	12 V AC/DC
Surge voltage limitation $U_O$	>33 V DC	-	-
Max. continuous load current $I_L$ per channel	500 mA	50 mA	500 mA
Min. switching current	-	1 mA	10 mA
Max. interrupting rating, ohmic load	-	-	-
24 V DC	12 W	1.2 W	12 W
48 V DC	-	-	20 W
60 V DC	-	-	18 W
110 V DC	-	-	23 W
220 V DC	-	-	40 W
250 V AC	-	-	115 VA
Residual voltage at $I_O$	<200 mV	-	-
Output circuit	Suppressor diode	-	-
Surge voltage limitation O1 ... O4	>33 V DC	-	-

EMC regulations	EMM 3- 24DC/...	EMM 3-230AC/...
Noise immunity according to	EN 61000-6-2	EN 61000-6-2
Noise emission (environmental category) according to	EN 61000-6-3 (B)	EN 61000-6-3 (A)
Increased EMC requirements according to	EN 62061	EN 62061

## CONTACTRON motor management

Measuring system, electrical data	EMM .../500AC-IFS	EMM .../500AC-16-IFS
Rated operating voltage $U_e$ According to IEC 60947-1	500 V AC	500 V AC
Operating voltage range According to IEC 60947-1 According to UL 508 / UL 60947-4-1-(A) / UL 60947-1(A)	42 ... 575 V AC 42 ... 500 V AC	42 ... 575 V AC 42 ... 500 V AC
Input current for voltage measurement	<0.5 mA	<0.5 mA
Rated operating current $I_e$ According to IEC 60947-1 According to UL 508 / UL 60947-4-1-(A) / UL 60947-1(A)	5 A AC external transformer 13 A FLA	16 A AC 13 A FLA
Min. operating current	140 mA	400 mA
Frequency range	40 ... 100 Hz	40 ... 100 Hz
Rated frequency according to IEC 60947-1	50 ... 60 Hz	50 ... 60 Hz
Output power of external transformer	$\geq 1.25$ VA	-
EMM internal resistance	0.02 $\Omega$	-
Current measurement	EMM .../500AC-IFS	EMM .../500AC-16-IFS
Measurement via (TR = Transformation ratio of external current transformer)	External straight-through current transformer connected upstream	Internal current transformer
Measuring range	0.15 ... 6 A x TR	0.4 ... 60 A
Accuracy	0.5%, typical	0.5%, typical
Voltage measurement	EMM .../500AC-IFS	EMM .../500AC-16-IFS
Measuring range	30 V AC ... 350 V AC star voltage 50 V AC ... 600 V AC line voltage	
Accuracy	0.75%, typical	0.75%, typical
Power measurement	EMM .../500AC-IFS	EMM .../500AC-16-IFS
Accuracy	2%, typical	2%, typical
Motor protection	EMM .../500AC-IFS	EMM .../500AC-16-IFS
Parameterizable current range	0.3 ... 6 A (4000 A, maximum, via external transformer)	1 ... 16 A up to Class 30 1 ... 14 A up to Class 40
Tripping time accuracy ( $t_{amb} = 20^\circ\text{C}$ )	$\pm 20\%$	$\pm 20\%$
Symmetry monitoring	EMM .../500AC-IFS	EMM .../500AC-16-IFS
Amount $(I_{max} - I_{min}) / I_{max}$	$\geq 33\%$ / $\geq 67\%$	
Response time	2 min/1.8 s	
Amount (angle (L1, L3))	220° ... 260°	
Response time	1.8 s	

## EMM 3-.../500AC...-IFS electronic motor management module

<b>Data interface</b>	<b>EMM .../500AC-IFS</b>	<b>EMM .../500AC-16-IFS</b>
Interface type	TBUS, S-PORT	
<b>Ambient conditions</b>		
Ambient temperature $t_{amb}$ (operation)	-25°C to +70°C (see derating curve)	
Ambient temperature $t_{amb}$ (transport, storage)	-40°C to +80°C	
<b>General data</b>		
Minimum/maximum power dissipation	1.5 W/2.5 W	2 W / 5.5 W
Nominal operating mode	100% operating factor	
Degree of protection according to EN 60529 (VDE 0470 Part 1)	IP20	
Mounting position (observe derating)	Vertical (horizontal DIN rail)	
Mounting	Can be aligned without spacing	
Coordination type EMM 3-.../500AC-16-IFS with IEC: 25 A diazed UL: 25 A LPS-RK-25-SP	2 (short-circuit-proof in the 10-kA network) 2 (short-circuit-proof in the 5-kA network)	
Power station requirement	DWR1300Zxx001/DD/70.80.8/830001:1985-08	
Low-voltage switchgear	IEC 60947-4-2: 2007-09	
Air clearances and creepage distances according to	IEC 60947-1: 2008-04	
Between the circuits	Safe isolation of input/output	
Thermistor input	Basic insulation of thermistor input/output	
Thermistor tripping mechanism	IEC 60947-8: 2007-07, DIN 44081, DIN 44082	
Rated insulation voltage	500 V	
Rated surge voltage	8 kV	
Overvoltage category	III	
Pollution degree	2	
FE connection	Via grounded DIN rail	
Housing material	PA 66	
Dimensions (width x height x depth)	22.5 mm x 99 mm x 114.5 mm	
Weight	180 g, approximately	
<b>Approvals</b>		
EC-type examination certificates according to ATEX	 II (2) G,  II (2) D PTB 10 ATEX 3024	
EC-type examination certificates according to UL 508 / UL 60947-4-1(A) / UL 60947-1(A)	NKCR File: E140324	
<b>Connection data</b>		
Screw terminal blocks (solid/stranded)	0.14 ... 2.5 mm <sup>2</sup>	
M3 thread, recommended tightening torque	0.5 Nm ... 0.6 Nm	
AWG	AWG 26-14	

CONTACTRON motor management

2.4.1 Derating curves

100% operating time; additional data available on request

Up to Class 30, the maximum inrush current for EMM-...16-IFS is 128 A, and for Class 35 and Class 40 it is 112 A.

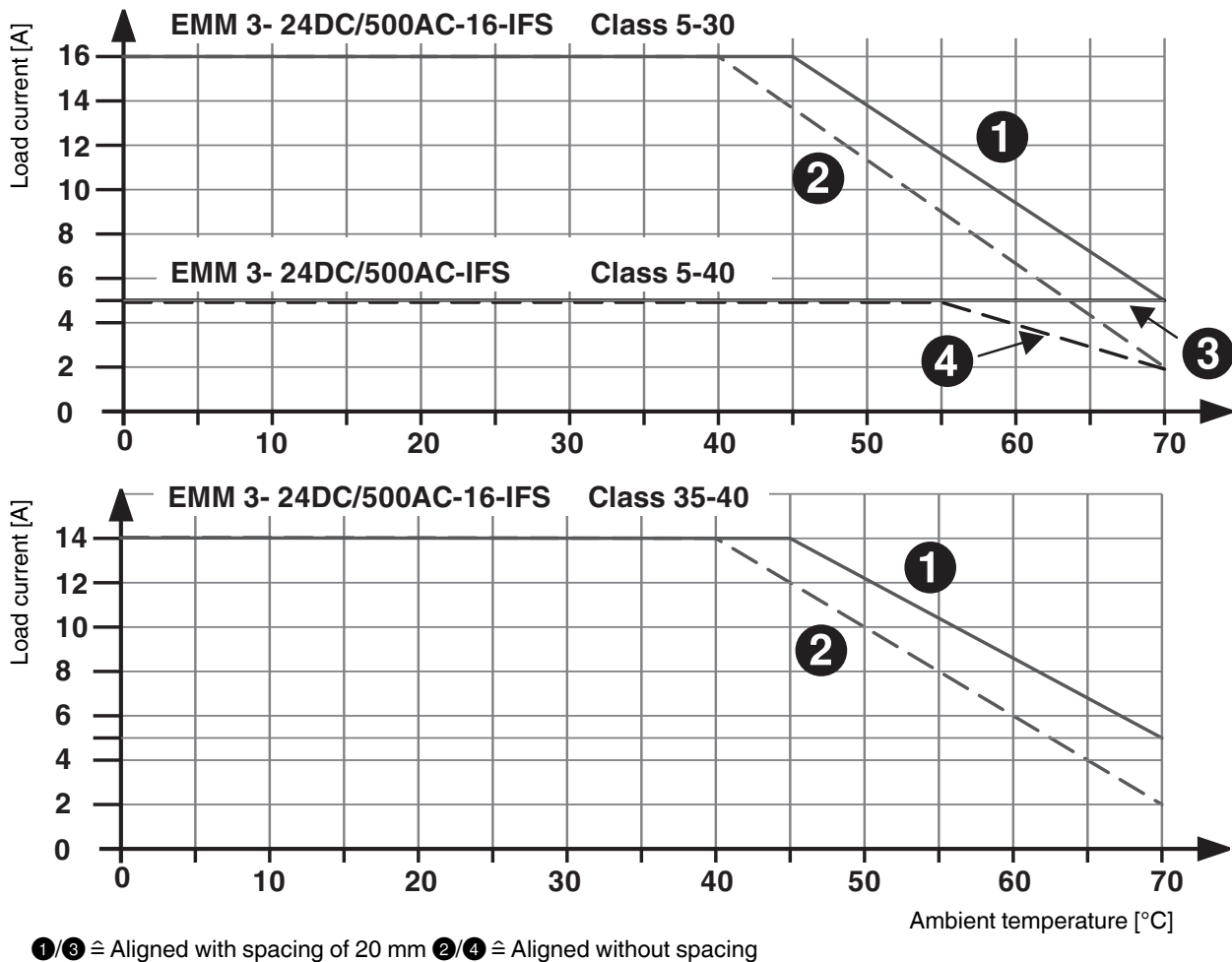
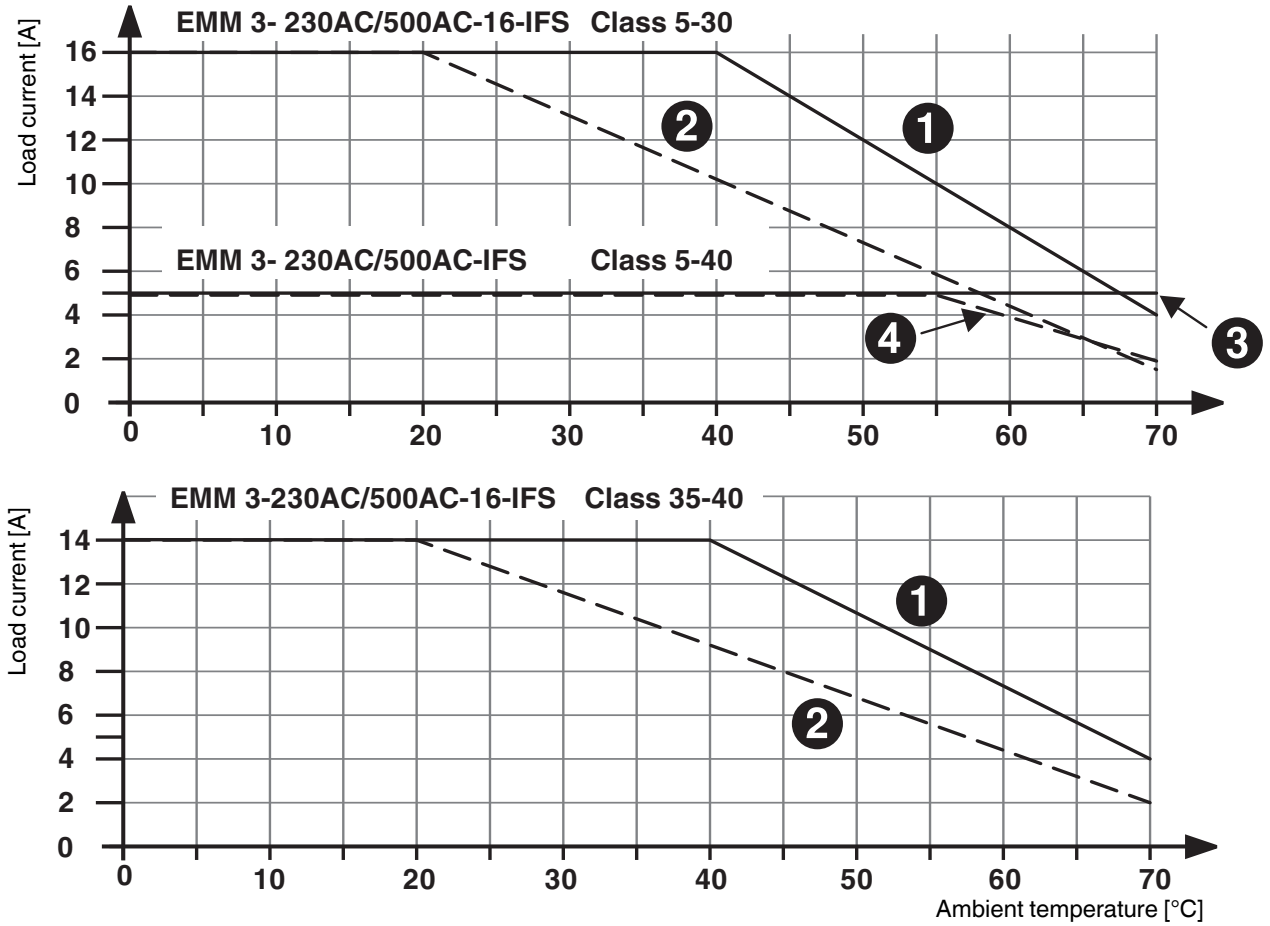

Figure 2-5 Derating curves, EMM 3- 24DC/...

EMM 3-.../500AC...-IFS electronic motor management module



①/③ ≙ Aligned with spacing of 20 mm ②/④ ≙ Aligned without spacing

Figure 2-6 Derating curves, EMM 3-230AC/...

CONTACTRON motor management

2.4.2 Tripping characteristics at 20°C

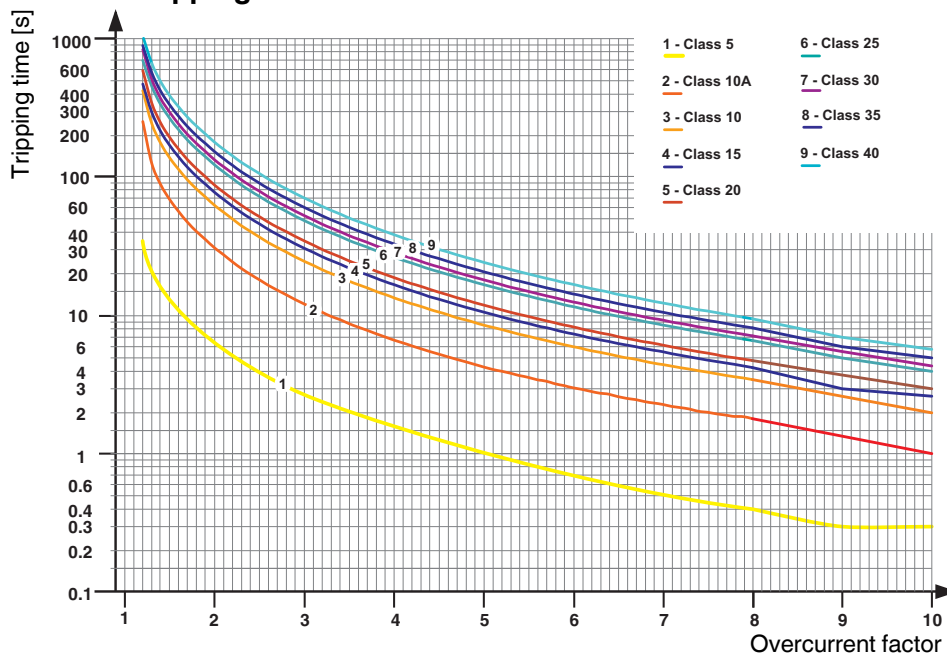

Figure 2-7 Tripping characteristic for 20°C (blocking protection)

The surge current factor is the ratio between the actual current and the parameterized nominal current.

Table 2-4 Tripping times [s] (5 A and 16 A averaged across entire temperature range)

I/IN3	Class 5	Class 10A	Class 10	Class 15	Class 20	Class 25	Class 30	Class 35	Class 40
1.2	34.6	236.0	403.0	456.0	574.0	678.0	808.0	864.0	1014.0
1.5	13.7	67.5	136.0	166.0	194.0	261.0	289.0	327.0	382.0
2	6.5	30.3	61.5	76.3	88.1	121.0	131.0	150.0	176.0
3	2.7	12.0	24.4	30.4	34.9	48.2	52.4	60.1	70.2
4	1.5	4.6	9.3	11.6	13.1	18.3	19.8	22.6	25.8
5	1.0	3.2	6.4	7.9	9.0	12.5	13.5	15.3	17.4
6	0.7	2.5	4.9	6.0	6.8	9.4	10.2	11.5	12.9
7	0.5	2.0	4.0	4.9	5.5	7.6	8.2	9.3	10.3
8	0.4	1.8	3.4	4.1	4.7	6.4	7.0	7.8	8.6
9	0.3	1.2	2.4	3	3.6	4.8	5.2	5.9	6.9
10	0.3	1	2	2.4	2.9	3.9	4.2	4.8	5.6



For the EMM 3-.../500AC-16-IFS, blocking monitoring is activated with a motor current of 60 A or higher (see tripping characteristic).

## EMM 3-.../500AC...-IFS electronic motor management module

According to the relevant tripping characteristic, shutdown occurs, at the latest, at eight times the current (surge current factor 8).

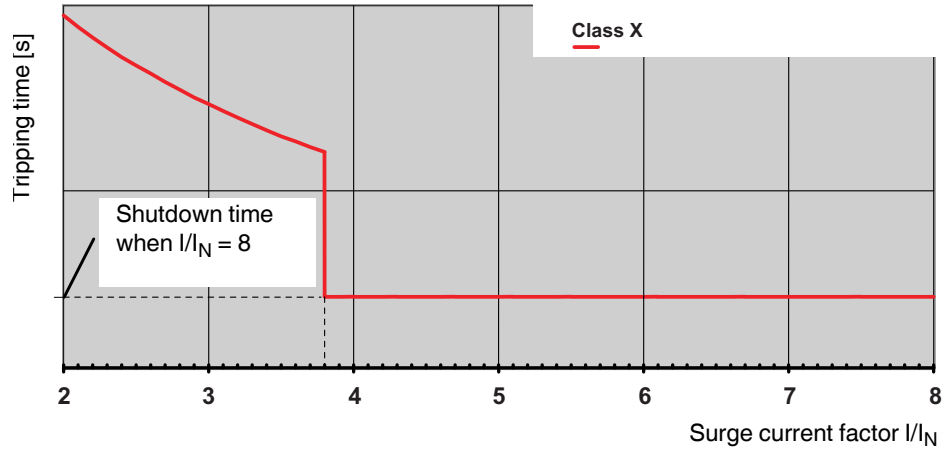

Figure 2-8 Shutdown time

The following tripping times apply for blocking monitoring according to the class curve:

Class	Tripping time
Class 5	0.4 s
Class 10A	1.8 s
Class 10	3.4 s
Class 15	4.1 s
Class 20	4.7 s
Class 25	6.4 s
Class 30	7.0 s
Class 35	7.8 s
Class 40	8.6 s

Example 1:

Parameterized nominal current  $I_N = 5 \text{ A}$  / surge current  $2 \times I_N = 10 \text{ A}$  / class curve = Class 5

The EMM shuts the outputs down after 6.5 s as the measuring range is not exceeded.

Example 2:

Parameterized nominal current  $I_N = 16 \text{ A}$  / surge current  $8 \times I_N = 128 \text{ A}$  / class curve = Class 30

The EMM shuts the outputs down after 7.0 s as the measuring range is exceeded.

## 2.5 Safety functions

Table 2-5 System conditions

Database	SN 29500
System type	Type B, comprising subsystems
Standard	IEC 61508
Beta factor	2%
MTTF [years] Mean time to failure at ambient temperature of 40°C	53.4 (EMM 3- 24DC/500AC-...); 19.8 (EMM 3-230AC/500AC-...)

**NOTE: Possible damage to the device**

When used in ATEX applications, at least one of the motor protection functions (thermistor monitoring or bimetal function) must be activated.

Safe shutdown	EMM 3- 24DC/...	EMM 3-230AC/...
Ambient temperature	40°C	40°C
MTTFd [years] - Mean time to dangerous failure	165	115
Shutdown time [ms]	40	80
$\lambda_{sd}$ [FIT] safe, detectable	225	236
$\lambda_{su}$ [FIT] safe, undetectable	678	1344
$\lambda_{dd}$ [FIT] dangerous, detectable	608	676
$\lambda_{du}$ [FIT] dangerous, undetectable	85	317
SFF [%] - Safe failure fraction	94.6	87.7
DCS [%] - Diagnostic coverage safe	24.8	14.9
DC [%] - Diagnostic coverage	87.7	68.1
PFH - Probability of failure per hour	$85 \times 10^{-9}$	$317 \times 10^{-9}$

Table 2-6 Safety level for safe shutdown

Standard	Level
IEC 61508-1	SIL 1
ISO 13849-1	PL b
EN 954-1	Category 1

## EMM 3-.../500AC...-IFS electronic motor management module

Motor protection by bimetal	EMM 3- 24DC/...	EMM 3-230AC/...
Ambient temperature	40°C	40°C
MTTFd [years] - Mean time to dangerous failure	480	220
Shutdown time [ms]	According to parameterized class curve, IEC 60947	
$\lambda_{sd}$ [FIT] safe, detectable	267	258
$\lambda_{su}$ [FIT] safe, undetectable	528	1123
$\lambda_{dd}$ [FIT] dangerous, detectable	130	193
$\lambda_{du}$ [FIT] dangerous, undetectable	109	328
SFF [%] - Safe failure fraction	90	83
DCS [%] - Diagnostic coverage safe	33.6	18.6
DC [%] - Diagnostic coverage	54.5	37

Table 2-7 Safety level for motor protection by bimetal

Standard	Level
IEC 61508-1	SIL 1

Motor protection by thermistor	EMM 3- 24DC/...	EMM 3-230AC/...
Ambient temperature	40°C	40°C
MTTFd [years] - Mean time to dangerous failure	534	230
Shutdown time [ms]	1000	1000
$\lambda_{sd}$ [FIT] safe, detectable	164	154
$\lambda_{su}$ [FIT] safe, undetectable	529	1124
$\lambda_{dd}$ [FIT] dangerous, detectable	115	178
$\lambda_{du}$ [FIT] dangerous, undetectable	99	319
SFF [%] - Safe failure fraction	89	82
DCS [%] - Diagnostic coverage safe	23.5	12.0
DC [%] - Diagnostic coverage	53.7	36

Table 2-8 Safety level for motor protection by thermistor

Standard	Level
IEC 61508-1	SIL 1

## CONTACTRON motor management

---



Additional safety data is available on request.

## 3 Configuration telegrams and measured values for gateways

### 3.1 Configuration telegrams

The gateway is a modular slave. Depending on the configuration, a distinction is made between “automatic IFSM configuration” and “configuration via DTM”.

For automatic configuration, the gateway generates the IFSM configuration and saves it to the connected slaves. However, the device addresses of the connected IFSM devices must be assigned manually first. Only use this operating mode for small stations.

#### 3.1.1 Digital input and output



**NOTE:**

The “Digital inputs/outputs” module is always active. It must always be initialized as the first module by the configuration telegram.

Table 3-1 OUT process data

Bit	Description
0	O1: Digital output 1
1	O2: Digital output 2
2	O3: Digital output 3
3	O4: Digital output 4
4	Reserved
5	Reserved
6	Reserved
7	Reserved
8	Reserved
9	Reserved
10	Reserved
11	Reserved
12	Reserved
13	Reserved
14	Reserved
15	Reserved

## CONTACTRON motor management

---

Bits I1 ... I8 mirror the state of the digital inputs of the gateway.

Table 3-2 IN process data

Bit	Description
0	I1: Digital input 1
1	I2: Digital input 2
2	I3: Digital input 3
3	I4: Digital input 4
4	I5: Digital input 5
5	I6: Digital input 6
6	I7: Digital input 7
7	I8: Digital input 8
8	Reserved
9	Reserved
10	Reserved
11	Reserved
12	Reserved
13	Reserved
14	Reserved
15	Reserved

### 3.1.2 Module status

The module status indicates the internal status of the gateway. It provides the same information that is found in the diagnostic telegram.

Table 3-3 Module status

Bit	Description
0	Device error (cannot be localized)
1	Reserved: Maximum device temperature exceeded
2	Manufacturer area of EEPROM, FLASH faulty
3	Configuration area of EEPROM, FLASH faulty
4	Supply voltage monitoring, reference voltage monitoring
5	Switching output monitoring (switching output overloaded)
6	Reserved
7	Configuration mode active
8	Reserved
9	Reserved
10	Reserved
11	Reserved
12	Memory stick faulty

---

**Configuration telegrams and measured values for gateways**

---

Table 3-3 Module status [...]

Bit	Description
13	Inter-channel communication faulty
14	ROM check faulty
15	Stack overflow

### 3.1.3 Station status

The station status indicates the status of the entire station in four individual registers. In the “Slave Error State 1” and “Slave Error State 2” registers, IFS devices are indicated as faulty; they are either not present or a serious internal error has occurred. An error in one of these registers causes a diagnostic telegram to be sent.

In “Slave Peripherie Error 1” and “Slave Peripherie Error 2”, devices which have detected an irregularity during operation are marked with “1”. This includes, for example, overloads, overranges, but also changes in the operating mode such as the parameterization mode being activated.

Table 3-4 Slave Error State 1

Bit	Description
0	Device 1: Faulty, not present, serious internal error
1	Device 2: Faulty, not present, serious internal error
2	Device 3: Faulty, not present, serious internal error
3	Device 4: Faulty, not present, serious internal error
4	Device 5: Faulty, not present, serious internal error
5	Device 6: Faulty, not present, serious internal error
6	Device 7: Faulty, not present, serious internal error
7	Device 8: Faulty, not present, serious internal error
8	Device 9: Faulty, not present, serious internal error
9	Device 10: Faulty, not present, serious internal error
10	Device 11: Faulty, not present, serious internal error
11	Device 12: Faulty, not present, serious internal error
12	Device 13: Faulty, not present, serious internal error
13	Device 14: Faulty, not present, serious internal error
14	Device 15: Faulty, not present, serious internal error
15	Device 16: Faulty, not present, serious internal error

**CONTACTRON motor management**

---

Table 3-5 Slave Error State 2

Bit	Description
0	Device 17: Faulty, not present, serious internal error
1	Device 18: Faulty, not present, serious internal error
2	Device 19: Faulty, not present, serious internal error
3	Device 20: Faulty, not present, serious internal error
4	Device 21: Faulty, not present, serious internal error
5	Device 22: Faulty, not present, serious internal error
6	Device 23: Faulty, not present, serious internal error
7	Device 24: Faulty, not present, serious internal error
8	Device 25: Faulty, not present, serious internal error
9	Device 26: Faulty, not present, serious internal error
10	Device 27: Faulty, not present, serious internal error
11	Device 28: Faulty, not present, serious internal error
12	Device 29: Faulty, not present, serious internal error
13	Device 30: Faulty, not present, serious internal error
14	Device 31: Faulty, not present, serious internal error
15	Device 32: Faulty, not present, serious internal error

Table 3-6 Slave Peripherie State 1

Bit	Description
0	Device 1: Process error, message
1	Device 2: Process error, message
2	Device 3: Process error, message
3	Device 4: Process error, message
4	Device 5: Process error, message
5	Device 6: Process error, message
6	Device 7: Process error, message
7	Device 8: Process error, message
8	Device 9: Process error, message
9	Device 10: Process error, message
10	Device 11: Process error, message
11	Device 12: Process error, message
12	Device 13: Process error, message
13	Device 14: Process error, message
14	Device 15: Process error, message
15	Device 16: Process error, message

---

**Configuration telegrams and measured values for gateways**

---

Table 3-7 Slave Peripherie State 2

<b>Bit</b>	<b>Description</b>
0	Device 17: Process error, message
1	Device 18: Process error, message
2	Device 19: Process error, message
3	Device 20: Process error, message
4	Device 21: Process error, message
5	Device 22: Process error, message
6	Device 23: Process error, message
7	Device 24: Process error, message
8	Device 25: Process error, message
9	Device 26: Process error, message
10	Device 27: Process error, message
11	Device 28: Process error, message
12	Device 29: Process error, message
13	Device 30: Process error, message
14	Device 31: Process error, message
15	Device 32: Process error, message

## CONTACTRON motor management

### 3.1.4 EMM objects

ELR/EMM Control (Device:1) ... ELR/EMM Control (Device:8)

Table 3-8 ELR/EMM Control

Bit	Description
15 ... 8	Status of the digital output information (O8 ... O1)
7	MSG reset: Group message; activation by positive edge
6	IND reset: Group error message; activation by positive edge
5 ... 3	Reserved
2	Left rotation request; activation by positive edge
1	Stop request; stop overrides all requests
0	Right rotation request; activation by positive edge

Table 3-9 ELR Status Word

Bit	Description
15 ... 8	Status of the digital inputs
7	MSG message: Group message
6	IND error: Group error message
5 ... 3	Reserved
2	Left rotation confirmation
1	Stop confirmation
0	Right rotation confirmation

Table 3-10 ELR/EMM Module State 1

Bit	Description
0	Device error (cannot be localized)
1	An error occurred when accessing the external EEPROM.
2	Channel 2: Manufacturer area of EEPROM, FLASH
3	Channel 2: Configuration area of EEPROM, FLASH
4	Channel 1: Configuration area of EEPROM, FLASH
5	Supply voltage monitoring, reference voltage monitoring
6	Reserved
7	Digital input monitoring
8	Error acknowledgment faulty
9	Channel 1: Logical program sequence monitoring faulty
10	Reserved
11	Channel 1: Return stack overflow

---

**Configuration telegrams and measured values for gateways**

---

Table 3-10 ELR/EMM Module State 1 [...]

Bit	Description
12	Channel 1: Data stack overflow
13	Channel 1: ROM monitoring
14	Channel 1: RAM monitoring
15	Channel 1: Saved reference value faulty

Table 3-11 ELR/EMM Module State 2

Bit	Description
0	Inter-channel communication to channel 1 faulty
1	Inter-channel communication to channel 2 faulty
2	An error occurred during the EEPROM synchronization
3	Group diagnostics for digital outputs (EMM 24DC)
4	Channel 1: GNDa has left the tolerance range
5	Reserved
6	Reserved
7	Test mode
8	Drive control: LOCAL 1
9	Drive control: LOCAL 2
10	Drive control: LOCAL 3
11	Drive control: Startup tool
12	Release of the configuration mode
13	Reserved
14	Cyclic bus communication
15	Reserved

Table 3-12 ELR/EMM Channel State 1

Bit	Description
0	Mains limit monitoring, working area underrange
1	Mains limit monitoring, working area overrange
2	Mains symmetry monitoring
3	Phase failure (UL1 - UL3)
4	Mains failure (mains regeneration time)
5	Mains synchronicity
6	Limit switch left
7	Limit switch right
8	Execution time at switch-on moment
9	Execution time at switch-off moment

## CONTACTRON motor management

---

Table 3-12 ELR/EMM Channel State 1 [...]

Bit	Description
10	Response time when switched off
11	Response time when switched on
12	Ground fault, insulation error (mains monitoring time)
13	Starts per time (pre-warning level)
14	Starts per time (error)
15	Output current flowing (5% nominal motor current)

Table 3-13 ELR/EMM Channel State 2

Bit	Description
0	Universal monitoring 1
1	Universal monitoring 2
2	Universal monitoring 3
3	Universal monitoring 4
4	Universal monitoring 5
5	Universal monitoring 6
6	Universal monitoring 7
7	Universal monitoring 8
8	“Left rotation” request
9	“Right rotation” request
10	Drive >>; (current flow is evaluated)
11	Drive >; (current flow is evaluated)
12	Drive o; (current flow is evaluated)
13	Drive <; (current flow is evaluated)
14	Drive <<; (current flow is evaluated)
15	Drive enabled

Table 3-14 ELR/EMM Channel State 3

Bit	Description
0	4 Hz cycle: The signal is inverted every 125 ms
1	10 Hz cycle: The signal is inverted every 50 ms
2	Group message
3	Group error message
4	Drive control: Automatic/manual
5	Simultaneous activation of left and right rotation
6	IFSM bus error
7	Fault in test mode

---

**Configuration telegrams and measured values for gateways**

---

Table 3-14 ELR/EMM Channel State 3 [...]

Bit	Description
8	Error acknowledgment 1
9	Error acknowledgment 2
10	Error acknowledgment 3
11	Error acknowledgment 4
12	Mains frequency invalid
13	Reserved
14	Reserved
15	Reserved

Table 3-15 ELR/EMM Channel State 4

Bit	Description
0	Safety-related disconnection, group 1
1	Safety-related disconnection, group 2
2	Error when restoring the system state
3	Symmetry error between IL1 and IL3
4	Phase failure (IL1 - IL3)
5	Blocking reached
6	Bimetal has tripped, acknowledgment only possible after minimum cooling time
7	Bimetal has tripped, acknowledgment possible
8	Interruption of motor line T1
9	Interruption of motor line T2
10	Interruption of motor line T3
11	Leaving the analog measuring range (EMM...5A)
12	Thermistor short circuit
13	Thermistor warning
14	Thermistor overtemperature
15	Thermistor wire break

### 3.2 Measured values - CONTACTRON motor manager EMM

An analog value is represented in a 16-bit data word in two's complement format (integer 16).

In addition to error code 8040h, which is generated by the gateway if it is not possible to communicate with the assigned slaves, other error codes are defined. They also relate to the status of the measured value, not the state of the connected device.

Table 3-16 Error codes

PDC	Error
8001 h	Out of measuring/representation range (overrange)
8002 h	Open circuit, mains fault
8004 h	No valid measured value available or invalid measured value
8010 h	Additional error information available
8020 h	PDC not activated
8040 h	Module faulty or not ready to operate
8080 h	Out of measuring/representation range (underrange)

The following example shows the scaling of the measured values and the assignment to the PDC codes.

±20 mA	±10 V	±30000 W	PDC data item
SL: -21,674	SL: -10.837	SL: -32512	
SH: 21,674	SH: 10.837	SH: 32512	
[mA]	[V]	[W]	[hex]
> +21.6746	> +10.837	> +32512	8001 Overage
+ 21.6746	+ 10.837	+ 32512	7F00 (32512)
+20.0000	+10.0000	+30000	7530 (30000)
+0.666667 m	+333.33 m	+1	0001 (1)
0	0	0	0000
-0.666667 m	-333.33 m	-1	FFFF (-1)
-20	-10	-30000	8AD0 (-30000)
-21.6746	-10.837	-32512	8100 (-32512)
< -21.6746	< -10.837	< -32512	8080 Underrange

---

**Configuration telegrams and measured values for gateways**
**3.2.1 Available measured values**

“P(ALL)”:	Real power
$\sqrt{3} \times \text{“U(L1)”}$ :	Conductor voltage L1
$\sqrt{3} \times \text{“U(L2)”}$ :	Conductor voltage L2
$\sqrt{3} \times \text{“U(L3)”}$ :	Conductor voltage L3
“I(L1)”:	Current, L1
“I(L2)”:	Current, L2
“I(L3)”:	Current, L3
“Energy”:	Power meter
“COS PHI”:	Cos Phi
“Frequency”:	Mains frequency
“Operation time(left)”:	Operating hours left
“Operation time(right)”:	Operating hours right
“Cycle(left)”:	Switching cycles left
“Cycle(right)”:	Switching cycles right
“P(L1)”:	Real power, L1
“P(L2)”:	Real power, L2
“P(L3)”:	Real power, L3
“Q(ALL)”:	Reactive power
“S(ALL)”:	Apparent power
“U(L1)”:	Voltage, L1
“U(L2)”:	Voltage, L2
“U(L3)”:	Voltage, L3



For power meters, operating hours counters, and operating cycle counters, an 8001h error code is not generated in the event of overrun (>32512). The counter is reset instead.

Additional status or measured values are available on request.

## CONTACTRON motor management

---

## 4 INTERBUS module IB IL IFS-MA(-2MBD)-PAC

The terminal is designed for use within an Inline station. It can be used to connect INTERFACE modules to the Inline station and thus the bus system used via the INTERFACE system bus.

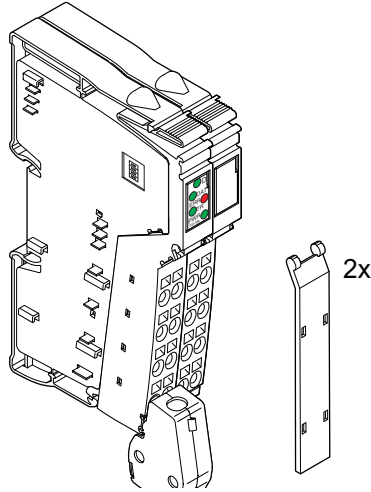

### Features

- Easy connection of INTERFACE EMM modules
- Data width in the local bus can be set via DIP switches depending on the number of connected INTERFACE devices
- Maximum data width from the INTERFACE system bus to the local bus: 32 words (including PCP)
- Maximum data width from the local bus to the INTERFACE system bus: 16 words
- Parameterization, configuration and diagnostics are possible via FDT/DTM (Field Device Tool/Device Type Manager)
- Serial interface (S-PORT) can be used to connect a memory stick
- Memory stick can be used for a configuration backup
- Applications:
  - Motor and energy management
  - Switching, protecting and monitoring of drives

### System requirements

- Inline controller ILC xxx
- Inline bus coupler for INTERBUS
- EMM, firmware 1.03 or later
- 8 EMM can be connected, maximum
- DTM library with data for the CONTACTRON motor management terminal: AX DTM LIB (AxDtmLib2Setup.exe Version 2.01.52 or later)
- DTM library with data for the electronic motor management modules: CONTACTRON DTM (CONTACTRONDtmSetupContactronDtmSetup\_3v22Rc20a.exe or later version)
- When working with PC Worx:
  - AUTOMATIONWORX Software Suite 2009 1.50, Service Pack 3 or later, or
  - PC Worx 6.00 Service Pack 3

## CONTACTRON motor management

## 4.1 Ordering data

## Products

Description	Type	Order No.	Pcs./Pkt.
Inline terminal for connecting the INTERFACE system bus, complete with accessories (connectors, labeling fields, and memory stick); transmission speed of 500 kbaud	IB IL IFS-MA-PAC	2692720	1
Inline terminal for connecting the INTERFACE system bus, complete with accessories (connectors, labeling fields, and memory stick); transmission speed of 2 Mbaud	IB IL IFS-MA-2MBD-PAC	2700815	1

## Accessories

Description	Type	Order No.	Pcs./Pkt.
Connector set with a standard connector and a shield connector (replacement item)	IB IL AO/CNT-PLSET	2732664	1 set
Memory stick (replacement item)	IFS-CONFSTICK	2986122	1
Memory stick (replacement item)	IFS-CONFSTICK-L	2901103	1
IL-IFS connecting cable; 2 m in length	IMC 1,5/ 5-ST-3,81SET IL IFS 2M	1784729	1
Plug, nominal current: 8 A, rated voltage (III/2): 160 V, pitch: 3.81 mm, color: green, metal surface: Sn	IMC 1,5/ 5-ST-3,81	1857919	50
Plug, nominal current: 8 A, rated voltage (III/2): 160 V, pitch: 3.81 mm, color: green, metal surface: Sn	MC 1,5/ 5-ST-3,81	1803604	50

## Documentation

Description	Type	Order No.	Pcs./Pkt.
User manual Automation terminals of the Inline product range	IL SYS INST UM E	-	-
Data sheet INTERBUS addressing	DB GB IBS SYS ADDRESS	-	-
Quick start guide Starting up the CONTACTRON motor management terminal with PC Worx	UM QS EN IB IL IFS-MA-PAC	-	-

## 4.2 Technical data

General data	
Housing dimensions (width x height x depth)	24.4 mm x 135.0 mm x 71.5 mm (with connectors)
Weight	130 g (with connectors)
Operating mode	Process data operation with up to 31 words; 1, 2, or 4 words PCP
Permissible temperature (operation)	-25°C to +55°C
Permissible temperature (storage/transport)	-25°C to +85°C
Permissible humidity (operation/storage/transport)	10% to 95%, according to DIN EN 61131-2
Permissible air pressure (operation/storage/transport)	70 kPa to 106 kPa (up to 3000 m above sea level)
Degree of protection	IP20 according to IEC 60529
Protection class	Class III according to EN 61131-2, IEC 61131-2
Pollution degree	2

**INTERBUS module IB IL IFS-MA(-2MBD)-PAC****General data [...]**

Connection data for Inline connectors

Connection method	Spring-cage terminal blocks
Conductor cross section	0.08 mm <sup>2</sup> to 1.5 mm <sup>2</sup> (solid or stranded), 28 - 16 AWG

**Interfaces****Bus**

Local bus	Via data routing
Transmission speed	
IB IL IFS-MA-PAC	500 kbps
IB IL IFS-MA-2MBD-PAC	2 Mbps

**INTERFACE system bus**

Number	1
Type	Single wire CAN

**Programming interface (S-PORT)**

Number	1
Type	Serial

**Supply of the module electronics through the bus coupler**

Connection technology	Potential routing
-----------------------	-------------------

**Supply of the connected INTERFACE modules****9 V supply**

Voltage range	8.1 V ... 9.9 V
Safety equipment	Short-circuit protection, electronic
Current carrying capacity	300 mA, maximum

**24 V supply (EMM)**

Voltage range	19.2 V ... 30.0 V, ripple included
Safety equipment	Short-circuit protection, electronic and thermal
Current carrying capacity	4 A, maximum

**Power consumption**

Communications power $U_L$	7.5 V
Current consumption at $U_L$	66 mA, typical; 78 mA, maximum
Main supply $U_M$	24 V DC (nominal voltage)
Permissible range	19.2 V DC ... 30.0 V DC, ripple included
Current consumption at $U_M$ (for 9 V bus supply)	141 mA, typical; 300 mA, maximum
Total power consumption	0.495 W, typical; 0.585 W, maximum (approximately)

**Power dissipation**

Power dissipation in the module	$P_{EL} = 1.285 \text{ W}$
Power dissipation of the housing $P_{HOU}$	1.4 W, maximum (within the permissible operating temperature)

## CONTACTRON motor management

---

### Limitation of simultaneity, derating

No limitation of simultaneity, no derating

### Safety equipment

None

### Electrical isolation/isolation of the voltage areas

#### - Test distance

Supply UM, bus, and logic/INTERFACE interface

Supply UM, bus, and logic/functional earth ground

INTERFACE interface/functional earth ground

#### - Test voltage

500 V AC, 50 Hz, 1 min

500 V AC, 50 Hz, 1 min

500 V AC, 50 Hz, 1 min

### Error messages to the higher-level control or computer system

9 V power supply faulty

Group error message, INTERFACE system bus error

### Approvals

For the latest approvals, please visit [phoenixcontact.net/products](http://phoenixcontact.net/products).

### 4.3 Internal basic circuit diagram

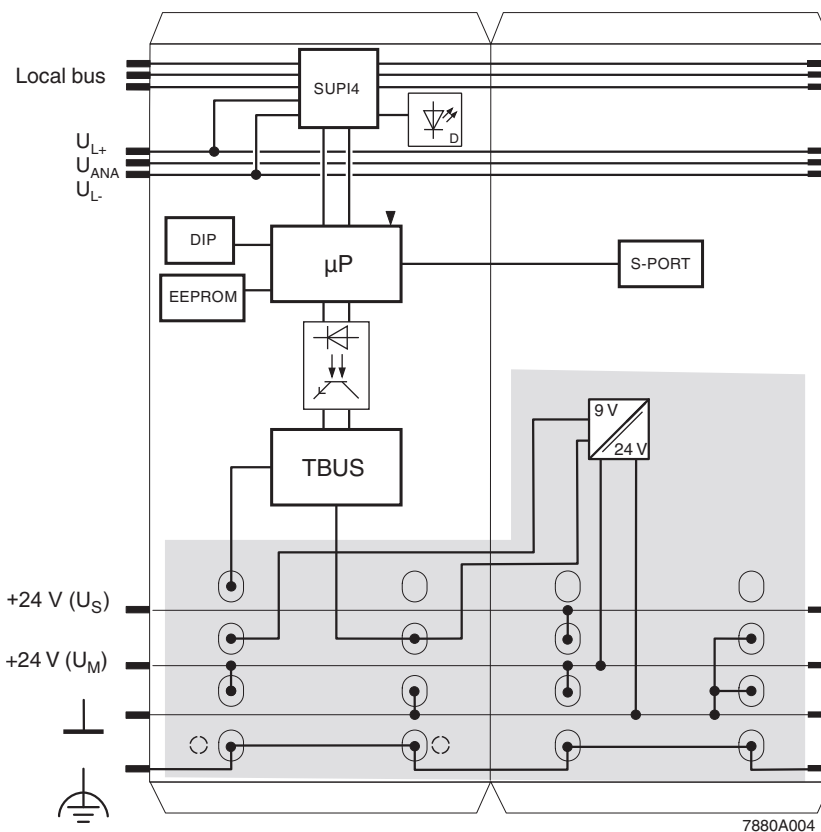











Figure 4-1 Internal wiring of the terminal points

Key:

- |   |  |  |   |
|---|--|--|---|
|  | Protocol chip (bus logic including voltage conditioning)   |  | Optocoupler                               |
|  | Diagnostic and status indicators with function information |  | Logic for the INTERFACE system bus        |
|  | Microprocessor   |  | S-PORT (programming interface)            |
|  | DIP switch   |  | DC/DC converter with electrical isolation |
|  | EEPROM   |  |   |



Other symbols used are explained in the IL SYS INST UM E user manual.

### 4.4 Terminal point assignment of the Inline and COMBICON connectors

The pre-assembled IMC 1,5/ 5-ST-3,81SET IL IFS 2M cable is available for connecting the INTERFACE system bus (see "Ordering data" on page 52). It is two meters long and equipped with the IMC 1,5/ 5-ST-3,81 MINI COMBICON connector on one side. The other end is free for connection to the Inline connector.

If you do not want to use the pre-assembled cables, you may assemble the connecting cable yourself (for the recommended connector, please refer to "Ordering data" on page 52).

Only Inline connector 1 needs to be connected for correct operation.

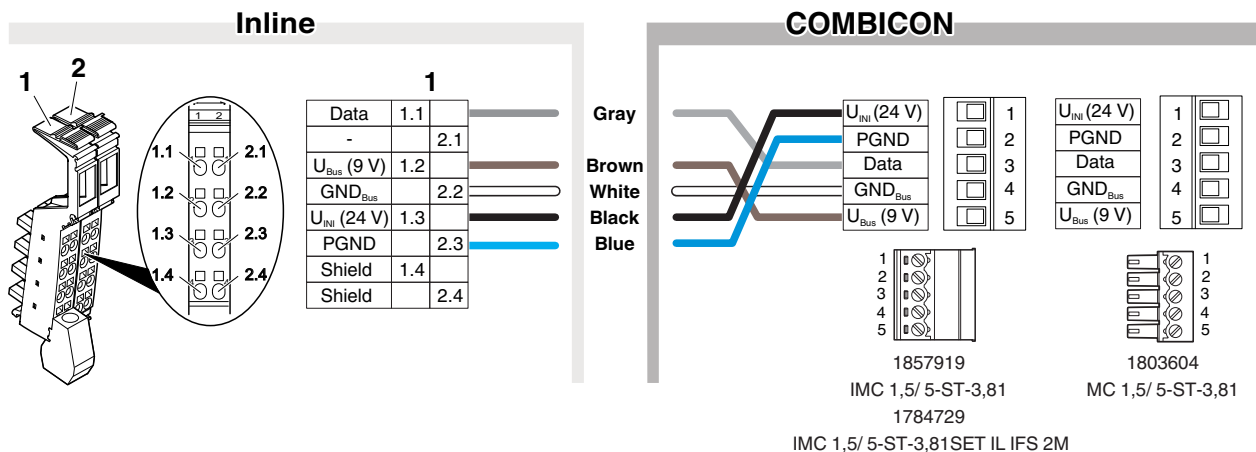

Figure 4-2 Terminal point assignment and connection diagram of the Inline and COMBICON connectors

## INTERBUS module IB IL IFS-MA(-2MBD)-PAC

## Inline connector 1

Inline	Signal	Assignment	Color in the pre-assembled cable	COMBICON
1.1	Data	Data	Gray	3
1.2	$U_{BUS}$ (9 V)	9 V supply (logic of the INTERFACE system bus)	Brown	5
1.3	$U_{INI}$ (24 V, $U_M$ )	24 V initiator supply (I/O of the INTERFACE system bus)	Black	1
2.1	–	Not used	–	–
2.2	$GND_{BUS}$	GND (logic of the INTERFACE system bus)	White	4
2.3	PGND	PGND (I/O of the INTERFACE system bus)	Blue	2
1.4, 2.4	Shield	Shield connection	–	–

## Inline connector 2

Inline	Signal	Assignment
1.1	–	Not used
1.2	$U_S$ (24 V)	24 V segment supply
1.3	$U_{INI}$ (24 V, $U_M$ )	24 V initiator supply
2.1	–	Not used
2.2	PGND	PGND
2.3	PGND	PGND
1.4, 2.4	FE	Functional earth ground

## 4.5 Diagnostic and status indicators

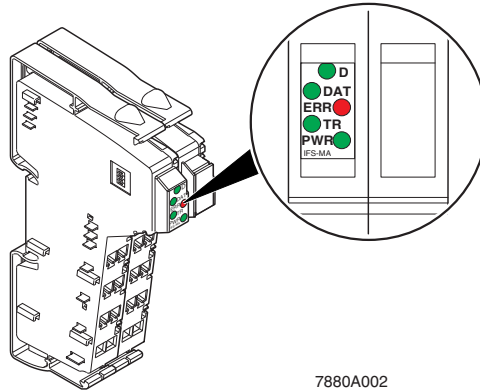

Figure 4-3 Diagnostic and status indicators

### 4.5.1 Local diagnostic and status indicators

Des.	Color	Meaning
<b>D</b>	<b>Green</b>	<b>Diagnostics</b> (see IL SYS INST UM E)
<b>DAT</b>	<b>Green</b>	<b>Data transmission</b>
	On	Cyclic data transmission via the INTERFACE system bus
	Flashing (slow, 1.4 Hz)	Device is being configured
	Flashing (medium, 2.8 Hz)	See "Local diagnostic and status indicators when using a memory stick" on page 59
Off	No communication with the INTERFACE system bus	
<b>ERR</b>	<b>Red</b>	<b>Error</b>
	On	Internal device error
	Flashing (slow, 1.4 Hz)	See "Local diagnostic and status indicators when using a memory stick" on page 59
	Flashing (medium, 2.8 Hz)	Peripheral fault (e.g., faulty power supply)
Off	No error	
<b>TR</b>	<b>Green</b>	<b>PCP</b>
	On	PCP active
	Off	PCP not active
<b>PWR</b>	<b>Green</b>	<b>9 V INTERFACE system bus supply</b>
	On	Supply present; microcontroller is running
	Flashing	Automatic address assignment is running
	Off	Supply not present; microcontroller does not start

### 4.5.2 Local diagnostic and status indicators when using a memory stick

PWR	DAT	ERR	
On	Any	Any	Normal operating mode, device status indicator
On	Flashing (slow, 1.4 Hz)	Flashing (slow, 1.4 Hz)	For a maximum of 6 s after plugging in the memory stick: The configuration on the stick is valid and can be stored by pressing the button.
On	Flashing (slow, 1.4 Hz)	Flashing (medium, 2.8 Hz)	After 6 s: The configuration on the device and on the memory stick are valid but different.
On	Flashing (slow, 1.4 Hz)	Off	Progress indicator. Reading or writing in progress.
On	Flashing (medium, 2.8 Hz)	Flashing (medium, 2.8 Hz)	Error when using the memory stick; confirm the message by removing the memory stick.

## 4.6 Function identification

Orange

## 4.7 Setting the data width on the local bus with DIP switches

Since the INTERFACE system can have different extensions it is necessary to adapt the data width.

A 4-pos. DIP switch is located on the left side of the housing. Set the data width with this switch.

The module reads the switch position after connecting the voltage (power-up). The data width cannot be changed during operation.



Set the data width before you install the terminal since the switch can no longer be accessed when the terminal is installed.



**NOTE: Observe the system limits**

When you set the data width, please observe the system limits of the bus coupler and/or the controller used. Take into account the permissible number of process, parameter, and configuration data.

## CONTACTRON motor management



Recommendation for setting the PCP data width in order to optimize the data transmission speed:

**1 word:** Select a width of one PCP word if you want to parameterize the terminal during startup only.

**4 words:** Select a width of four PCP words if you often access the terminal via acyclic services during operation.

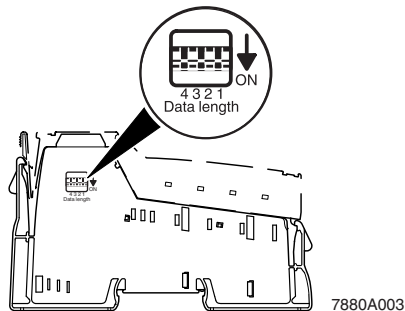

Figure 4-4 DIP switch for setting the data width

Data width depending on the DIP switches (in words):

DIP (4 ... 1)	PD IN	PD OUT	PD in bits	PCP	Local bus	ID	
0000	Reserved						
0001	4	4	64	1	5	223/DF	
0010	8	8	128	1	9		
0011	13	13	208	1	14		
0100	Reserved						
0101	25	16	400	1	26		
0110	Reserved						
0111	31	16	496	1	32		
1000	Reserved						
1001	4	4	64	4	8	221/DD	
1010	8	8	128	4	12		
1011	12	12	192	4	16		
1100	20	16	320	4	24		
1101	22	16	352	4	26		
1110	28	16	448	4	32		
<b>1111</b>	<b>30</b>	<b>16</b>	<b>480</b>	<b>2</b>	<b>32</b>	<b>220/DC</b>	

DIP (4 ... 1): Setting of the DIP switches

PD IN: Width of the IN process data in words

PD OUT: Width of the OUT process data in words

---

**INTERBUS module IB IL IFS-MA(-2MBD)-PAC**

---

PD in bits:	Width of the process data in bits; to determine the required device description in the engineering tool
PCP:	Width of the PCP channel in words
Local bus:	Width on the local bus in words
ID:	ID code in dec and hex format
Marked in bold:	Default setting (upon delivery)

**PD in bits:**

Select the device description for the IB IL IFS-MA-PAC terminal according to the ID code and the process data length.

Examples of device descriptions:

- IB\_IL\_IFS-MA\_ID\_220\_PD\_480...
- IB\_IL\_IFS-MA\_ID\_221\_PD\_64...
- ...
- IB\_IL\_IFS-MA\_ID\_221\_PD\_448...
- IB\_IL\_IFS-MA\_ID\_223\_PD\_64...
- ...
- IB\_IL\_IFS-MA\_ID\_223\_PD\_496...

### 4.8 Connection example

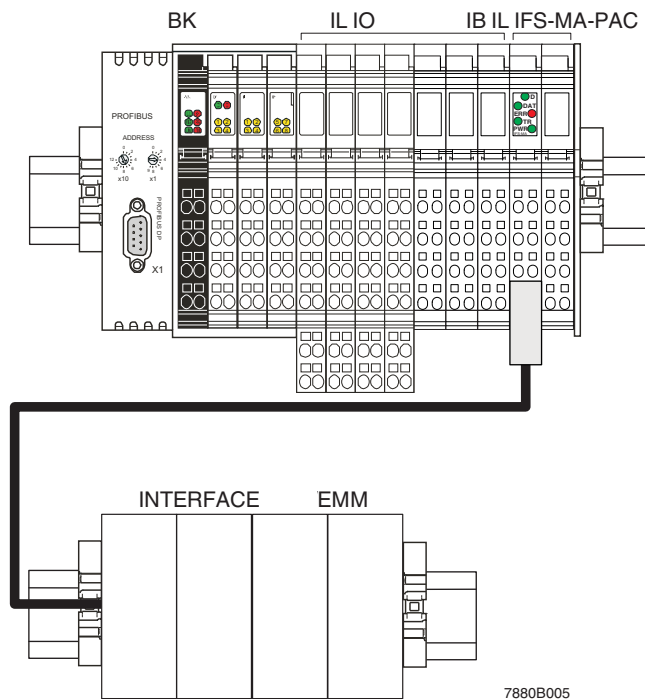

Figure 4-5 Connection example

Key:

- BK Bus coupler (e.g., for PROFIBUS here)
- IL IO Inline terminals according to your application
- IB IL IFS-MA-PAC Inline terminal for connecting the INTERFACE system bus
- INTERFACE EMM/EMM Modules of the INTERFACE system bus

### 4.9 Connection note



**NOTE:**

The cable to connect the INTERFACE system bus should be up to 10 m long (maximum) in order to ensure error-free data transmission.

Phoenix Contact recommends using the pre-assembled cable according to “Ordering data” on page 52 for connection of the INTERFACE system bus.

## 4.10 Programming data/configuration data

### 4.10.1 Local bus (INTERBUS)

ID code	DF <sub>hex</sub> (223 <sub>dec</sub> )	DC <sub>hex</sub> (220 <sub>dec</sub> )	DD <sub>hex</sub> (221 <sub>dec</sub> )
Length code	04 <sub>hex</sub> ... 1F <sub>hex</sub>	1E <sub>hex</sub>	04 <sub>hex</sub> ... 1C <sub>hex</sub>
Process data channel	Variable	480 bits	Variable
Input address area	4 ... 31 words	30 words	4 ... 28 words
Output address area	4 ... 31 words	30 words	4 ... 28 words
Parameter channel (PCP)	1 word	2 words	4 words
Register length (bus)	5 ... 32 words	32 words	8 ... 32 words

### 4.10.2 Other bus systems



For the programming data/configuration data of other bus systems, please refer to the corresponding electronic device data sheet (e.g., GSD, EDS).

## 4.11 Process data

The process data can be handled via the DTM.

Every analog value is represented in a 16 bit data word in two's complement format, based on the Inline format.

When an error occurs, the following diagnostic codes will be mapped to the process data:

Code (hex)	Error
8001	Overrange, above measuring/representation range
8002	Open circuit, mains fault
8004	Measured value invalid/no valid measured value available
8010	Additional error information available
8020	Process data channel not activated
8040	Module is faulty or not ready for operation
8080	Underrange, below measuring/representation range

## 4.12 Configuring/parameterizing the device

A DTM (Device Type Manager) is available for the INTERBUS bus system (see “System requirements” on page 51). You can use the DTM to configure and parameterize the module with a FDT (Field Device Tool).



For detailed information on the DTM, please refer to the quick start guide (see “Ordering data” on page 52)

## 4.13 Programming interface (S-PORT)

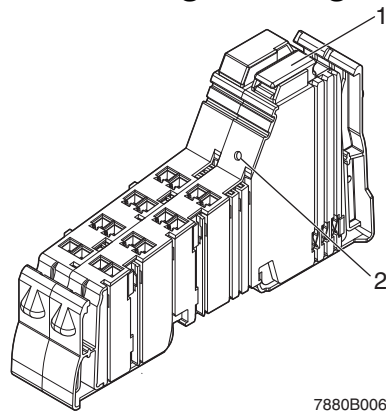

Figure 4-6 S-PORT and button

- 1 S-PORT programming interface
- 2 Button to start copying the configuration and parameterization data

The S-PORT programming interface is located on the right-hand side of the housing. This interface can be used to configure the INTERFACE system bus.

By default upon delivery, a memory stick is inserted on the S-PORT.

## 4.14 S-PORT: Using the memory stick

A memory stick is available to store the configuration and parameterization data (inserted by default upon delivery; see “Ordering data” on page 52).

If the device detects a memory stick during power-up, it checks whether the configuration on the memory stick is suitable and valid.

The DAT and ERR LEDs flash alternately when the configuration on the memory stick and the configuration of the INTERFACE system bus are different (see also “Diagnostic and status indicators” on page 58). The device functions are not affected by this.

The DAT and ERR LEDs flash rapidly if the data on the stick is unsuitable or corrupt (see also “Diagnostic and status indicators” on page 58).

If a memory stick is inserted during configuration via the DTM, consistency between the configuration data on the stick and the internal memory is ensured by the device firmware. All write commands to the internal memory are executed on the memory stick as well after the configuration has been completed.

#### **4.14.1 Saving the device configuration**

It may be necessary to save the configuration of a device on a separate memory stick. To do this, proceed as follows:

- Remove the original memory stick.
- Press the button (2 in Figure 4-6) with an appropriate tool, for example, a ball-point pen. This will start the copying process of the configuration and parameterization data.
- Afterwards, insert the memory stick on which the data is to be saved within 4 seconds.

The DAT LED flashes while saving.

If errors are detected while saving or the later check, the DAT and ERR LEDs flash simultaneously at medium speed. These errors do not affect the device functions, which means that the device continues to work at full capacity or remains in the error state that was previously adopted.

Once the memory stick has been removed or the save procedure has been completed successfully, the LEDs reflect the current device status.

#### **4.14.2 Loading or restoring the configuration data**

The device detects a memory stick when it is inserted during power-up or when it is inserted during operation.

The stored configuration data is checked after recognition of the stick.

##### **The device has never been configured**

If the device has never been configured, there are two options:

1. If the configuration on the stick is valid, the configuration will be transmitted immediately. The DAT LED flashes during the process. After the transmission is complete, the device is marked as “already configured” and is started with the new configuration.
2. If the configuration on the stick is invalid or if an error occurred during the transmission, the DAT and ERR LEDs flash at medium speed (until the memory stick is removed). Since the device has not been parameterized before, it is in a safe state.

## CONTACTRON motor management

---

### Device is already configured

If the device has already been configured, there are two options:

1. If the configuration on the stick is invalid or if an error was detected when the stick was inserted, this will be indicated by the DAT and ERR LEDs flashing at medium speed. The LEDs will flash until the memory stick is removed. This does not affect the device functions, which means that the device continues to work at full capacity or remains in the error state that was previously adopted.
2. If the configuration on the stick is valid, but is different from the previous configuration, the DAT and ERR LEDs flash alternately for 6 seconds.  
If the button is pressed within 6 seconds, the configuration data is copied from the memory stick to the internal memory. The DAT LED flashes while copying.  
After power-up, the device is started with the new configuration.  
If the button is not pressed within 6 seconds, the DAT and ERR LEDs will flash simultaneously at medium speed after 6 seconds. This indicates that the configuration on the stick and the device are different.  
The flashing stops when the memory stick is removed.
3. If the configuration on the stick is identical with the previous configuration, the module uses the previous configuration. The configuration from the stick will not be copied.

## 4.15 DTM functions

The following DTM functions are available:

- Establishing a connection (connect)
- Disconnecting the connection (disconnect)
- Assigning process data
- Displaying a device list, naming lower-level devices
- Displaying the data sheet
- Uploading parameters
- Downloading parameters
- Displaying, monitoring, specifying data of a lower-level device



For detailed information on the DTM, please refer to the quick start guide (see "Ordering data" on page 52)

## 5 PROFIBUS bus coupler for INTERFACE system devices

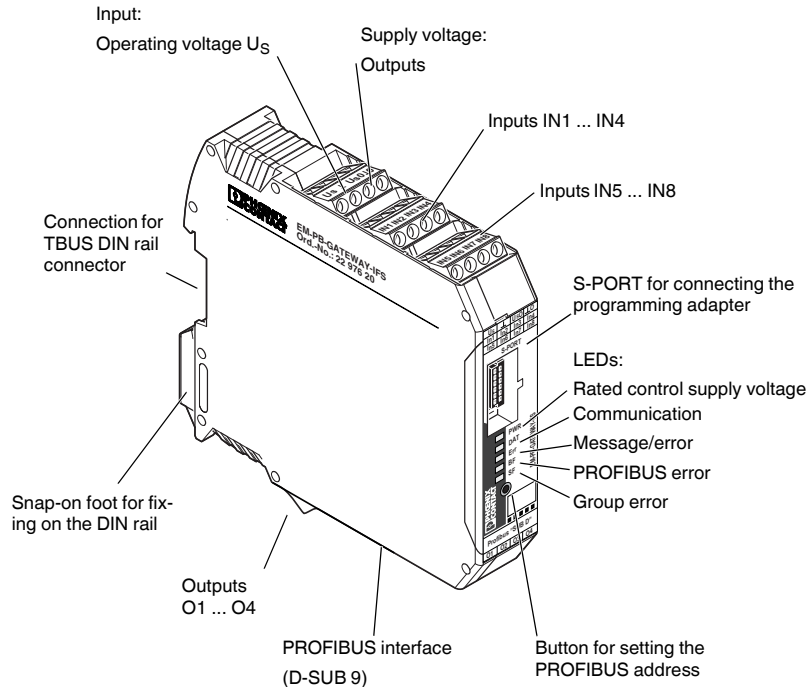

Figure 5-1 EM-PB-GATEWAY-IFS

The EM-PB-GATEWAY-IFS PROFIBUS module (Order No. 2297620) is a module that enables EMM...IFS modules to be connected to PROFIBUS DP. The module is certified according to specification DPV1 (EN 50170).

The EM-PB-GATEWAY-IFS can communicate with up to 32 EMM...IFS modules (slaves) via TBUS. Eight digital inputs and four outputs can be freely used. The gateway can be operated by any standard-compliant C0 master in cyclic data exchange. It also supports acyclic connections.

In addition, the EM-PB-GATEWAY-IFS supports the fail safe state: the switching behavior in the event of PROFIBUS errors can be influenced by the parameterization.

The assignment of the process data can be individually adapted to the application requirements by means of the GSD file (device master data). The GSD file (containing the characteristic communication features of the PROFIBUS module) is available on the Internet at [phoenixcontact.net/products](http://phoenixcontact.net/products).

The PROFIBUS address is set using a button and/or a device (PC, memory stick, actuator) connected to the S-PORT as an option. The module does not provide PROFIBUS termination, an appropriate connector should be used for this, if required.

**CONTACTRON motor management**

---

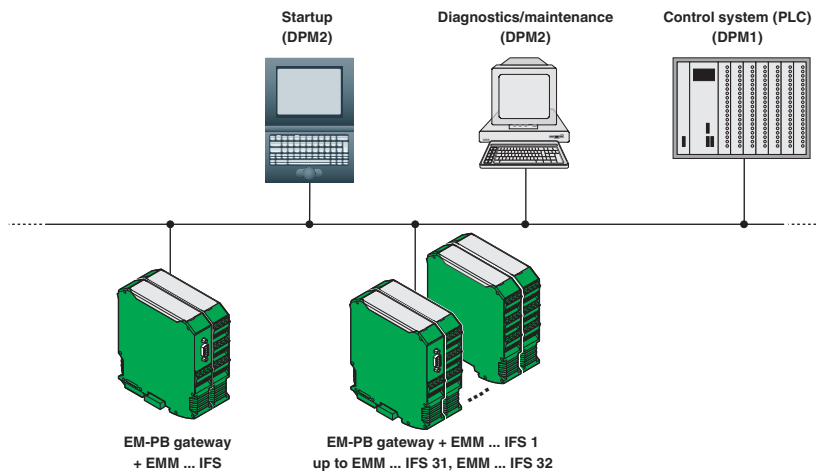

Figure 5-2 PROFIBUS module for electronic motor management modules

## 5.1 Definition of terms

PROFIBUS DP	PROFIBUS bus system with the DP protocol. DP stands for distributed periphery. The main task of PROFIBUS DP is fast cyclic data exchange between the central DP master and the I/O devices.
PROFIBUS DPV1	PROFIBUS DPV1 is an extension of the DP protocol. This means that acyclic data exchange of parameter, diagnostic, control, and test data is also possible.
DP master	A master that behaves according to standard EN 50170, Volume 2, PROFIBUS, with the DP protocol, is referred to as a DP master.
Class 1 master	A class 1 master is an active device in PROFIBUS DP. Cyclic data exchange with other devices is clearly indicated. Typical class 1 masters include PLCs with PROFIBUS DP connection.
Class 2 master	These types of devices are engineering, configuration or operating devices. They are used during startup, maintenance, and diagnostics to configure the connected devices, evaluate measured values, and request the device state.
DP slave, DP standard slave	A slave that is operated on the PROFIBUS bus with the PROFIBUS DP protocol and behaves according to standard EN 50170, Volume 2, PROFIBUS, is referred to as a DP slave.
DPV1 slave, xS7 slave	The EM-PB-GATEWAY-IFS is a DPV1 slave with the following properties: <ul style="list-style-type: none"> <li>– Supports the S7 model (diagnostic alarms, process alarms)</li> <li>– Can be parameterized</li> <li>– Reads/writes data records</li> </ul>
Type files/GSD	Device master data (GSD) contains DP slave descriptions in a uniform format. Using GSD simplifies the configuration of the master and DP slave.

## 5.2 Connection notes

### 5.2.1 Mains connection and line protection



**WARNING: Dangerous contact voltage**

Never carry out work when voltage is present

This work may only be carried out by qualified personnel who are familiar with the necessary safety precautions.

The rated control supply voltage and control voltage inputs must be operated with power supply modules according to DIN 19240 (maximum residual ripple of 5%).

In order to avoid inductive or capacitive coupling of disturbing pulses where long control lines are used, we recommend using shielded cables.



**CAUTION: Wiring safety**

If you want to clamp two conductors under one terminal point, you must use conductors with the same conductor cross section.

### 5.2.2 Block diagram

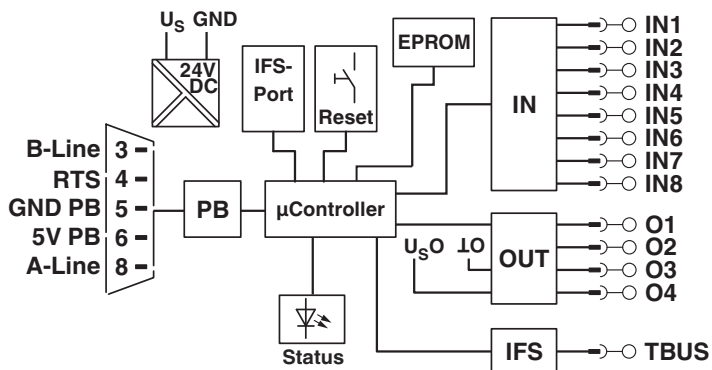

Figure 5-3 Block diagram

### 5.2.3 TBUS DIN rail connector

The EM-PB-GATEWAY-IFS can be mounted on a DIN rail. For detailed information about mounting/removal, please refer to Section "TBUS DIN rail connector" on page 143.

## PROFIBUS bus coupler for INTERFACE system devices

### 5.2.4 Status LEDs

Five LEDs visualize the various operating states of the gateway.



The status LEDs are used to indicate the PROFIBUS address and the addresses of the connected IFS devices in parameterization mode when setting the address.

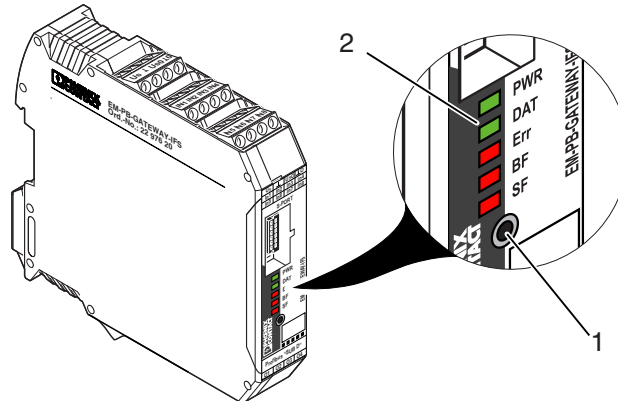

Figure 5-4 Operating and indication elements

- 1 Button for setting the PROFIBUS address
- 2 Status LEDs

LED	Description
<b>PWR LED (green)</b> Off On Flashing at 1.4 Hz (slow) Flashing at 2.8 Hz (fast)	<b>Device status</b> No supply voltage. Microcontroller does not start. Supply voltage OK. Microcontroller is running. Setting the PROFIBUS address IFS address assignment
<b>DAT LED (green)</b> Off On Flashing at 1.4 Hz (slow) Flashing at 2.8 Hz (fast)	<b>Communication</b> No data traffic Cyclic data traffic Device is being configured See Section 13, "IFS-CONFSTICK(-L) memory block"
<b>ERR LED (red)</b> Off On Flashing at 1.4 Hz (slow) Flashing at 2.8 Hz (fast)	<b>Device or process error</b> No error Serious internal error See Section 13, "IFS-CONFSTICK(-L) memory block" I/O error, e.g., overload of the output driver
<b>BF LED (red)</b> Off On Flashing at 1.4 Hz (slow) Flashing at 2.8 Hz (fast)	<b>PROFIBUS error</b> No error No cyclic data exchange (C1 master not present) PROFIBUS parameterization invalid PROFIBUS configuration invalid

## CONTACTRON motor management

LED [...]	Description
<b>SF LED (red)</b>	<b>Group error</b>
Off	No error
On	Connected device has an internal error or is not present
Flashing at 1.4 Hz (slow)	Process error or I/O error on a device
Flashing at 2.8 Hz (fast)	PROFIBUS configuration and station structure do not match

### 5.2.5 S-PORT handling

The EM-PB-GATEWAY-IFS supports active extensions, e.g., IFS-USB-PROG-ADAPTER USB programming adapter (Order No. 2811271) or the IFS-USB-DATACABLE data cable (Order No. 2320500), as well as an optional IFS-CONFSTICK-L memory stick (Order No. 2901103).

### 5.2.6 Setting the PROFIBUS address

1. Press and hold down the button 1 (Figure 5-4 “Operating and indication elements”) for at least six seconds (6 s).
2. The LEDs on the EM-PB-GATEWAY-IFS indicate the current PROFIBUS address offset.
3. Set the PROFIBUS address offset by pressing button 1 on the EM-PB-GATEWAY-IFS (see table).
4. Press button 1 on the EM-PB-GATEWAY-IFS for six seconds (6 s).



The EM-PB-GATEWAY-IFS calculates the PROFIBUS address by adding the offset to the base address.

The base address is set to 0 by default and can be modified by means of the DTM.

**PROFIBUS bus coupler for INTERFACE system devices**

Table 5-1 PROFIBUS address

LED code					Offset
PWR	DAT	ERR	BF	SF	
0	0	0	0	0	0
0	0	0	0	1	1
0	0	0	1	0	2
0	0	0	1	1	3
0	0	1	0	0	4
0	0	1	0	1	5
0	0	1	1	0	6
0	0	1	1	1	7
0	1	0	0	0	8
0	1	0	0	1	9
0	1	0	1	0	10
0	1	0	1	1	11
0	1	1	0	0	12
0	1	1	0	1	13
0	1	1	1	0	14
0	1	1	1	1	15
1	0	0	0	0	16
1	0	0	0	1	17
1	0	0	1	0	18
1	0	0	1	1	19
1	0	1	0	0	20
1	0	1	0	1	21
1	0	1	1	0	22
1	0	1	1	1	23
1	1	0	0	0	24
1	1	0	0	1	25
1	1	0	1	0	26
1	1	0	1	1	27
1	1	1	0	0	28
1	1	1	0	1	29
1	1	1	1	0	30
1	1	1	1	1	31

Default offset



Button 1 can only be used to change the offset address. The base address is changed by means of the DTM.

### 5.2.7 Setting the INTERFACE system address

1. Press button 1 (Figure 5-4 “Operating and indication elements”) for 12 seconds (12 s).
2. The LEDs on the EM-PB-GATEWAY-IFS indicate the current IFS address of the first device on the IFS bus.
3. Set the IFS address by pressing button 1 on the EM-PB-GATEWAY-IFS (see table).
4. Press the button on the first device, for example:  
EMM...IFS = Reset button  
The IFS address is applied on the first device.
5. The address of the next device is indicated on the EM-PB-GATEWAY-IFS. Repeat steps 3 and 4 until all the devices have been addressed.
6. Press and hold down button 1 for at least six seconds (6 s).
7. All status LEDs light up briefly.



The INTERFACE system addresses can also be set using the IFS-Conf software (see “Connecting several devices via an IFS gateway” on page 159).

---

**PROFIBUS bus coupler for INTERFACE system devices**

---

Table 5-2 INTERFACE system address

Table 5-3 LED code					IFSM address
PWR	DAT	ERR	BF	SF	
0	0	0	0	0	32
0	0	0	0	1	1
0	0	0	1	0	2
0	0	0	1	1	3
0	0	1	0	0	4
0	0	1	0	1	5
0	0	1	1	0	6
0	0	1	1	1	7
0	1	0	0	0	8
0	1	0	0	1	9
0	1	0	1	0	10
0	1	0	1	1	11
0	1	1	0	0	12
0	1	1	0	1	13
0	1	1	1	0	14
0	1	1	1	1	15
1	0	0	0	0	16
1	0	0	0	1	17
1	0	0	1	0	18
1	0	0	1	1	19
1	0	1	0	0	20
1	0	1	0	1	21
1	0	1	1	0	22
1	0	1	1	1	23
1	1	0	0	0	24
1	1	0	0	1	25
1	1	0	1	0	26
1	1	0	1	1	27
1	1	1	0	0	28
1	1	1	0	1	29
1	1	1	1	0	30
1	1	1	1	1	31

## 5.3 PROFIBUS telegrams

### 5.3.1 Structure of the parameterization telegram

Each time the EM-PB-GATEWAY-IFS is started up on PROFIBUS DP, parameters are transmitted to the device. Depending on the master module used, either standard parameters or standard and IF system-specific parameters are transmitted.

The setting of the startup parameters is defined by the GSD file and carried out using the configuration tool of the master module.

Table 5-4 Parameterization telegram

Parameter	Value/description
Behavior at PROFIBUS errors	0: Reset outputs and Producer PDCs 1: Hold last state
Control of digital outputs	0 = Output is controlled by PB 1 = Output is controlled by IFS master Bit 3: Output 4 Bit 2: Output 3 Bit 1: Output 2 Bit 0: Output 1
Real power [W] (x 0.001): 1000	Measuring range final value for real power Representation range (default): -32512 ... 32512 W
Reactive power [var] (x 0.001): 1000	Measuring range final value for reactive power [var] Representation range (default): -32512 ... 32512 var
Power [VA] (x 0.001): 1000	Measuring range final value for apparent power [VA] Representation range (default): -32512 ... 32512 VA
Voltage [V] (x 0.001): 100	Measuring range final value for voltage [V] Representation range (default): -3251.2 ... 3251.2 V
Current [A] (x 0.001): 1	Measuring range final value for current [A] Representation range (default): -32.512 ... 32.512 A
Switch cycles (x 1): 1	Measuring range final value for operating cycle counters Representation range (default): 0 ... 32512 cycles
Operation time [h] (x 0.001): 1	Measuring range final value for operating hours counter Representation range (default): 0 ... 32.512 h
Energy [kWh] (x 0.001): 1	Measuring range final value for power meter Representation range (default): -32.512 ... 32.512 kWh
Userdefined 1 (x 0.001): 1000	Representation range (default): -32512 ... 32512
Userdefined 2 (x 0.001): 1000	Userdefined Scaling 2 (x 0.001) Representation range (default): -32512 ... 32512
IFS-Application	0: NON 1: ELR, EMM

**PROFIBUS bus coupler for INTERFACE system devices**

---

Table 5-4 Parameterization telegram [...]

<b>Parameter</b>	<b>Value/description</b>
Byte order	0: Intel 1: Motorola

## CONTACTRON motor management

### 5.3.2 Structure of the diagnostic telegram

The diagnostic telegram indicates the current operating state of the devices. It is sent when requested by the PROFIBUS master.

The system distinguishes between status and error messages. Error messages are marked "E" and are sent to the master with high priority, i.e., as soon as an error is detected, diagnostic data is sent to the master instead of process data. However, status messages are only sent if no process data needs to be transmitted.

Table 5-5 Diagnostic telegram

Byte	Bit	Remark	
0	7 ... 0	Station status 1 (DP standard)	
1	7 ... 0	Station status 2 (DP standard)	
2	7 ... 0	Station status 3 (DP standard)	
3	7 ... 0	Address of the PROFIBUS master	
4	7 ... 0	Slave ID (high byte)	
5	7 ... 0	Slave ID (low byte)	
6	7 ... 0	07h: Header of device-specific diagnostics (DPV1)	
7	7 ... 0	81h: Type of diagnostics	
8	7 ... 0	00h: Slot number	
9	7 ... 0	00h: Reserved	
10	Module state (Low Byte) (LPC/DPC) Errors		
	7	Configuration mode is set	M
	6	Reserved	
	5	Switch output overload	E
	4	Error power supply detected	E
	3	Checksum config area is invalid	E
	2	Checksum vendor area is invalid	E
	1	Reserved	
11	Module state (High Byte) DPC Errors		
	7	Stack error	E
	6	Checksum ROM is invalid	E
	5	Internal communication error	E
	4	Digital input error	E
	3	Reserved	M
	2	Reserved	M
	1	Reserved	M
0	Reserved	E	

---

**PROFIBUS bus coupler for INTERFACE system devices**

---

Table 5-5 Diagnostic telegram [...]

Byte	Bit	Remark	
12		IFSM Slave Error 1 (faulty module or device is not present)	
	7	Slave 8: error or missing	E
	6	Slave 7: error or missing	E
	5	Slave 6: error or missing	E
	4	Slave 5: error or missing	E
	3	Slave 4: error or missing	E
	2	Slave 3: error or missing	E
	1	Slave 2: error or missing	E
13		IFSM Slave Error 2 (faulty module or device is not present)	
	7	Slave 16: error or missing	E
	6	Slave 15: error or missing	E
	5	Slave 14: error or missing	E
	4	Slave 13: error or missing	E
	3	Slave 12: error or missing	E
	2	Slave 11: error or missing	E
	1	Slave 10: error or missing	E
14		IFSM Slave Error 3 (faulty module or device is not present)	
	7	Slave 24: error or missing	E
	6	Slave 23: error or missing	E
	5	Slave 22: error or missing	E
	4	Slave 21: error or missing	E
	3	Slave 20: error or missing	E
	2	Slave 19: error or missing	E
	1	Slave 18: error or missing	E
15		IFSM Slave Error 4 (faulty module or device is not present)	
	7	Slave 32: error or missing	E
	6	Slave 31: error or missing	E
	5	Slave 30: error or missing	E
	4	Slave 29: error or missing	E
	3	Slave 28: error or missing	E
	2	Slave 27: error or missing	E
	1	Slave 26: error or missing	E
16		IFSM Slave Process, Periphery Error 1	
	7	Slave 8: process or periphery error	M

## CONTACTRON motor management

Table 5-5 Diagnostic telegram [...]

Byte	Bit	Remark	
	6	Slave 7: process or periphery error	M
	5	Slave 6: process or periphery error	M
	4	Slave 5: process or periphery error	M
	3	Slave 4: process or periphery error	M
	2	Slave 3: process or periphery error	M
	1	Slave 2: process or periphery error	M
	0	Slave 1: process or periphery error	M
	17		IFSM Process, Periphery Error 2
7		Slave 16: process or periphery error	M
6		Slave 15: process or periphery error	M
5		Slave 14: process or periphery error	M
4		Slave 13: process or periphery error	M
3		Slave 12: process or periphery error	M
2		Slave 11: process or periphery error	M
1		Slave 10: process or periphery error	M
18		IFSM Process, Periphery Error 3	
	7	Slave 24: process or periphery error	M
	6	Slave 23: process or periphery error	M
	5	Slave 22: process or periphery error	M
	4	Slave 21: process or periphery error	M
	3	Slave 20: process or periphery error	M
	2	Slave 19: process or periphery error	M
	1	Slave 18: process or periphery error	M
19		IFSM Device Process, Periphery 4	
	7	Slave 32: process or periphery error	M
	6	Slave 31: process or periphery error	M
	5	Slave 30: process or periphery error	M
	4	Slave 29: process or periphery error	M
	3	Slave 28: process or periphery error	M
	2	Slave 27: process or periphery error	M
	1	Slave 26: process or periphery error	M
20		Channel state 1	
	7	Reserved	M
	6	Reserved	M
	5	Reserved	M

---

**PROFIBUS bus coupler for INTERFACE system devices**

---

Table 5-5 Diagnostic telegram [...]

Byte	Bit	Remark	
	4	Reserved	M
	3	Reserved	M
	2	Reserved	M
	1	Reserved	M
	0	Reserved	M
21		Channel state 2	
	7	"IFSM-Bus-Error"	M
	6	"IFSM-Bit-Error"	M
	5	"IFSM-Cyclic-Data"	M
	4	"IFSM-Acyclic-Data"	M
	3	"IFSM-Invalid-Bus-Cycle-Time"	M
	2	Reserved	M
	1	Reserved	M
0	Reserved	M	
22		Channel state 3	
	7	Reserved	M
	6	Reserved	M
	5	Reserved	M
	4	Reserved	M
	3	Reserved	M
	2	Reserved	M
	1	Reserved	M
0	Reserved	M	
23		Channel state 4	
	7	Reserved	M
	6	Reserved	M
	5	Reserved	M
	4	Reserved	M
	3	Reserved	M
	2	Reserved	M
	1	Reserved	M
0	Reserved	M	

## 5.4 Technical data

<b>EM-PB-GATEWAY-IFS</b>	<b>2297620</b>	
<b>Supply</b>		
Rated control supply voltage $U_S$	24 V DC -20% ... +25%	
Rated control supply current $I_S$	85 mA plus load current of the outputs	
Input circuit	Surge protection Protection against polarity reversal	
<b>Digital inputs IN1 ... IN8</b>		
Rated actuating voltage $U_c$	24 V DC -20% ... +20%	
Rated actuating current $I_S$	3 mA	
Input circuit	Surge protection Protection against polarity reversal	
<b>Digital outputs O1 ... O4</b>		
Maximum switching voltage	23 V DC ( $U_S - U_{Residual}$ of the output)	
Maximum switching current	500 mA	
Residual voltage $U_{Residual}$ at 500 mA	1 V DC	
Output circuit	Parallel protection against polarity reversal (6.3 A fuse, maximum)	
<b>General data</b>		
Test voltage	1.5 kV	
Data interface/supply	100% operating factor	
Nominal operating mode	100% operating factor	
Degree of protection	IP20	
Pollution degree	2	
Overvoltage category	III	
Standards/regulations	EN 50178	
Mounting position	Any	
Mounting	Can be aligned without spacing	
Housing material	Polyamide PA, non-reinforced	
Dimensions (width x height x depth)	22.5 mm x 114.5 mm x 99 mm	
Conductor cross section	0.2 mm - 2.5 mm <sup>2</sup> (24 - 12 AWG)	
Plug-in COMBICON screw connection		
<b>Data interface</b>	<b>IFS</b>	<b>PROFIBUS</b>
Data rate	76.8 kbps	9.6 kbps ... 12 Mbps
Connection method	TBUS, S-PORT	D-SUB 9
<b>Ambient conditions</b>		
Ambient temperature (operation)	-35°C ... +50°C	
Ambient temperature (storage/transport)	-35°C ... +80°C	

## 6 CANopen bus coupler for INTERFACE system devices



For additional information, please refer to the “EM-...-GATEWAY-IFS” quick start guide. This document can be downloaded at [phoenixcontact.net/products](http://phoenixcontact.net/products).

### 6.1 Safety notes

- Please observe the safety regulations of electrical engineering and industrial safety and liability associations.
- Disregarding these safety regulations may result in death, serious personal injury or damage to equipment.
- Startup, mounting, modifications, and upgrades may only be carried out by a skilled electrical engineer.
- Operation in a closed control cabinet according to IP54.
- Before working on the device, disconnect the power.
- During operation, parts of electrical switching devices carry hazardous voltages.
- Protective covers must not be removed when operating electrical switching devices.
- In the event of an error, replace the device immediately.
- Repairs to the device, particularly the opening of the housing, must only be carried out by the manufacturer.
- Keep the operating instructions in a safe place.

### 6.2 Short description

The EM-CAN-GATEWAY-IFS gateway (Order No. 2901504) is used for connecting devices of the INTERFACE system range to a CANopen network.

Up to 32 devices (slaves) can be connected.

The assignment of the process data can be individually adapted to your application requirements using the gateway DTM. The DTM is also used for easy integration in an FDT environment.



The gateway DTM can be downloaded at [phoenixcontact.net/products](http://phoenixcontact.net/products).

The address is set using a button or a PC or memory stick connected to the S-PORT.

The bus must be terminated in the bus connecting cable.

### 6.3 Block diagram

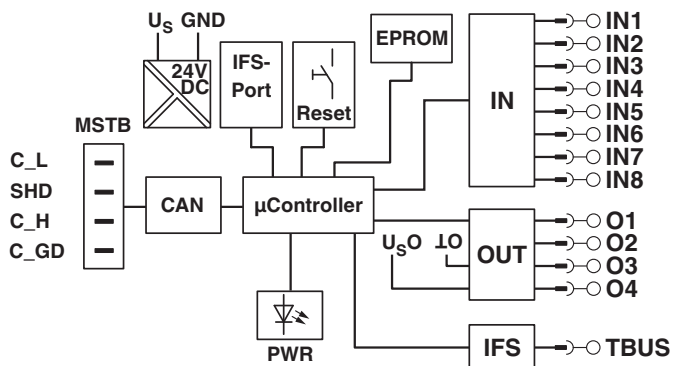

### 6.4 Operating elements

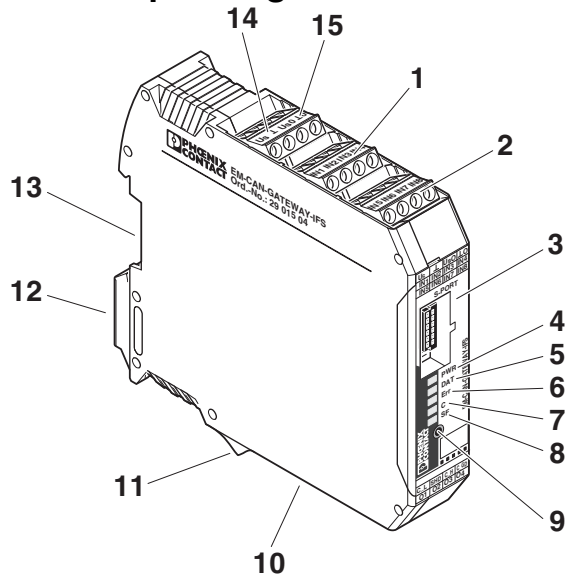



Figure 6-1 Operating and indication elements

1	Inputs IN1 to IN4	
2	Inputs IN5 to IN8	
3	S-PORT	Connection for programming adapter
4	PWR LED	Device status
5	DAT LED	IFS communication
6	ERR LED	Device or process error
7	C LED	CANopen status
8	SF LED	Station error
9	Button for setting the address	

## CANopen bus coupler for INTERFACE system devices

10	CAN interface
11	Outputs O1 to O4
12	Metal base latch for fixing on the DIN rail 
13	Connection for TBUS DIN rail connector
14	Input: Operating voltage $U_S$
15	Supply voltage for outputs O1 to O4

## 6.5 Connection notes

**NOTE:**

The rated control voltage inputs and control voltage inputs must be operated with power supply modules according to DIN 19240 (5% residual ripple, maximum).

In order to avoid inductive or capacitive coupling of noise emissions where long control wires are used, we recommend the use of shielded conductors.

If you want to connect multiple conductors to one terminal, you must use conductors with the same conductor cross section.

## 6.5.1 Mounting

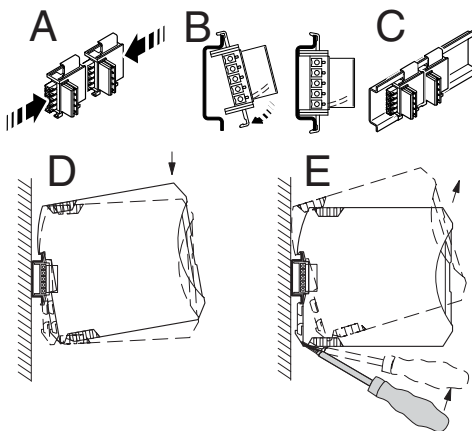
**CAUTION:**

Mounting/removal of the devices on/from the TBUS DIN rail connector may only be performed when no voltage is applied.

## CONTACTRON motor management

### TBUS DIN rail connector

The TBUS DIN rail connector makes the INTERFACE system communication and/or power supply of individual INTERFACE system devices possible.



**NOTE:**

The TBUS DIN rail connector can only be used to supply the modules if 24 V DC devices are used.

Connect the required number of TBUS DIN rail connectors (Order No. 2707437) together.

When placing the gateway onto the DIN rail, make sure that it is aligned correctly with the TBUS.

Power is supplied on the gateway or a power terminal. Observe the permissible current carrying capacity.

### 6.5.2 Bus termination

Bus termination for the CANopen bus is achieved using 120  $\Omega$  on the gateway on terminal blocks C\_L and C\_H.

Termination is already required with short cables and low baud rates.

In practice, termination at one end is sufficient in the case of short cables. Ideally, the bus is terminated on both ends (and only there) using 120  $\Omega$ .

## 6.6 LED status indicators

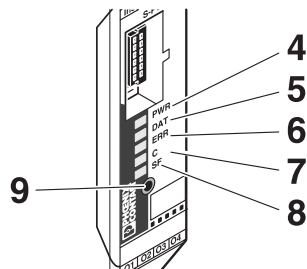

The five LEDs visualize the various operating states of the gateway.

LED	Status	Description
PWR	(Green) - <b>Device status</b>	
	Off	No supply voltage.
	On	Supply voltage OK.
	Flashing (1.4 Hz)	Setting the CANopen address
	Flashing irregularly (1.4 Hz)	Setting the transmission speed
	Flashing (2.8 Hz)	IFS address assignment

## CANopen bus coupler for INTERFACE system devices

LED	Status	Description
DAT	(Green) - <b>IFS communication</b>	
	Off	No data traffic
	On	Cyclic data traffic
	Flashing (1.4 Hz)	The device is being configured.
	Flashing (2.8 Hz)	See Section "IFS-CONFSTICK(-L) memory block" on page 139
	Flashing	Transmission speed is being set
ERR	(Red) - <b>Device or process error</b>	
	Off	There are no faults.
	On	Serious internal error
	Flashing (1.4 Hz)	<b>WARNING:</b> Overload of the output driver.
C	(Red/green) - <b>CANopen status</b> (according to CANopen specification)	
	Off	No supply voltage or the device is in the reset state.
	On (green)	"Operational" state: The device is ready to operate.
	Flashing (green/red)	Automatic baud rate detection is active.
	Flashing (green)	"Pre-operational" state: No PDO transmission possible.
	One flash (green)	"Stopped" state: Failsafe state; no PDO transmission possible.
	On (red)	CAN controller is not connected to the bus (bus off).
	One flash (red)	At least one error counter has reached the warning level.
	Two flashes (red)	A guard event or heartbeat event has been triggered.
	Three flashes (red)	Sync timeout error
SF	(Red) - <b>Station error</b>	
	Off	There are no faults.
	On	Internal device error or device not connected.
	Flashing (1.4 Hz)	Process error or I/O error in a device.

## 6.7 Setting and displaying the fieldbus address

- Press the button (9) for more than 4 seconds (PWR LED flashes). The gateway changes to the “fieldbus address parameterization” mode.

After releasing the button, the five LEDs indicate the current address offset.

Code					ON $\hat{=}$ <input type="checkbox"/>	Field Bus					Field Bus
PWR	DAT	ERR	C	SF		PWR	DAT	ERR	C	SF	Field Bus
4	5	6	7	8	Address	4	5	6	7	8	Address
					Offset						Offset
					0	•					16
				•	1	•				•	17
			•		2	•			•		18
			•	•	3	•			•	•	19
		•			4	•		•			20
		•		•	5	•		•		•	21
		•	•		6	•		•	•		22
		•	•	•	7	•		•	•	•	23
•					8	•	•				24
•				•	9	•	•			•	25
•		•			10	•	•			•	26
•		•	•		11	•	•		•	•	27
•	•				12	•	•	•			28
•	•			•	13	•	•	•		•	29
•	•	•			14	•	•	•	•		30
•	•	•	•		15	•	•	•	•	•	31

A basic address can be set using the gateway DTM (default = 0).

- Tapping on the button (9) increases the address offset up to a maximum value of “31”. Then the value is reset to “0”.
- Press the button (9) for more than 6 seconds in order to save the settings.



When not pressing the button (9) for 15 seconds, parameterization mode is quit without saving any settings.

## 6.8 Setting and displaying the transmission speed

- Press the button (9) for more than 8 seconds (PWR LED flashes). The gateway changes to the “transmission speed parameterization” mode.
- After releasing the button, the five LEDs indicate the index of the transmission speed.

Code <input type="checkbox"/> ON <input type="checkbox"/> OFF					Index	Transmission Speed [kBaud]
PWR 4	DAT 5	ERR 6	C 7	SF 8		
				•	1	Automatic detection (default)
			•		2	10
			•	•	3	20
		•			4	50
		•		•	5	100
		•	•		6	125
		•	•	•	7	250
	•				8	500
	•			•	9	1000

- Tapping on the button (9) increases the index up to a maximum value of “9”. Then the value is reset to “1”.
- Press the button (9) for more than 6 seconds in order to save the settings.



When not pressing the button (9) for 15 seconds, parameterization mode is quit without saving any settings.

## 6.9 Setting and displaying the INTERFACE system address

- Press the button (9) for more than 12 seconds (PWR LED flashes). The gateway changes to the "IFSM addressing" mode.

After releasing the button, the five LEDs indicate the current IFSM address.

Code					ON $\approx$ $\bullet$	IFSM Address	PWR	DAT	ERR	C	SF	IFSM Address
PWR	DAT	ERR	C	SF		IFSM Address	PWR	DAT	ERR	C	SF	IFSM Address
4	5	6	7	8		IFSM Address	4	5	6	7	8	IFSM Address
						32	$\bullet$					16
				$\bullet$		1	$\bullet$				$\bullet$	17
			$\bullet$			2	$\bullet$			$\bullet$		18
			$\bullet$	$\bullet$		3	$\bullet$			$\bullet$	$\bullet$	19
		$\bullet$				4	$\bullet$		$\bullet$			20
		$\bullet$	$\bullet$			5	$\bullet$		$\bullet$		$\bullet$	21
		$\bullet$	$\bullet$	$\bullet$		6	$\bullet$		$\bullet$	$\bullet$		22
		$\bullet$	$\bullet$	$\bullet$	$\bullet$	7	$\bullet$		$\bullet$	$\bullet$	$\bullet$	23
	$\bullet$					8	$\bullet$	$\bullet$				24
	$\bullet$			$\bullet$		9	$\bullet$	$\bullet$			$\bullet$	25
	$\bullet$		$\bullet$			10	$\bullet$	$\bullet$		$\bullet$		26
	$\bullet$		$\bullet$	$\bullet$		11	$\bullet$	$\bullet$		$\bullet$	$\bullet$	27
	$\bullet$	$\bullet$				12	$\bullet$	$\bullet$	$\bullet$			28
	$\bullet$	$\bullet$		$\bullet$		13	$\bullet$	$\bullet$	$\bullet$		$\bullet$	29
	$\bullet$	$\bullet$	$\bullet$			14	$\bullet$	$\bullet$	$\bullet$	$\bullet$		30
	$\bullet$	$\bullet$	$\bullet$	$\bullet$		15	$\bullet$	$\bullet$	$\bullet$	$\bullet$	$\bullet$	31

- Press the button on the first device connected (slave). The slave accepts the address previously indicated on the gateway (master).

The gateway automatically increases the current IFSM address by "one" so that another slave can be addressed on the IFS bus.

- Press the button on the next slave.
- Address any slaves on the IFS bus in the same manner.
- Press the button (9) on the gateway for more than 6 seconds in order to save the settings. All status LEDs light up briefly.

## CANopen bus coupler for INTERFACE system devices

## 6.10 Technical data

Parameter	Value
<b>Supply</b>	
Rated control supply voltage $U_s$	24 V DC -20% ... +25 %
Rated control supply current $I_s$	85 mA
<b>IFS interface</b>	
Transmission speed	76.8 kbps
Connection	TBUS S-PORT (connector)
<b>CANopen®</b>	
Transmission speed	10 kbps ... 1 Mbps
Connection	MSTB connector outlet
<b>General data</b>	
Test voltage	1.5 kV
Degree of protection	IP20
Ambient temperature range	Operation -25°C ... 50°C Storage/transport -35°C ... 80°C
Housing material	Polyamide PA, non-reinforced
Dimensions W/H/D	22.5 mm/99 mm/114.5 mm
<b>Approvals</b>	

## CONTACTRON motor management

---

## 7 DeviceNet bus coupler for INTERFACE system devices



For additional information, please refer to the “EM-...-GATEWAY-IFS” quick start guide. This document can be downloaded at [phoenixcontact.net/products](http://phoenixcontact.net/products).

### 7.1 Safety notes

- Please observe the safety regulations of electrical engineering and industrial safety and liability associations.
- Disregarding these safety regulations may result in death, serious personal injury or damage to equipment.
- Startup, mounting, modifications, and upgrades may only be carried out by a skilled electrical engineer.
- Operation in a closed control cabinet according to IP54.
- Before working on the device, disconnect the power.
- During operation, parts of electrical switching devices carry hazardous voltages.
- Protective covers must not be removed when operating electrical switching devices.
- In the event of an error, replace the device immediately.
- Repairs to the device, particularly the opening of the housing, must only be carried out by the manufacturer.
- Keep the operating instructions in a safe place.

### 7.2 Short description

The bus coupler module (gateway) is used for connecting devices of the INTERFACE system range to a DeviceNet network.

Up to 32 devices (slaves) can be connected.

The assignment of the process data can be individually adapted to your application requirements using the gateway DTM. The DTM is also used for easy integration in an FDT environment.



The gateway DTM can be downloaded at [phoenixcontact.net/products](http://phoenixcontact.net/products).

The address is set using a button or a PC or memory stick connected to the S-PORT.

The bus must be terminated in the bus connecting cable.

CONTACTRON motor management

7.3 Block diagram

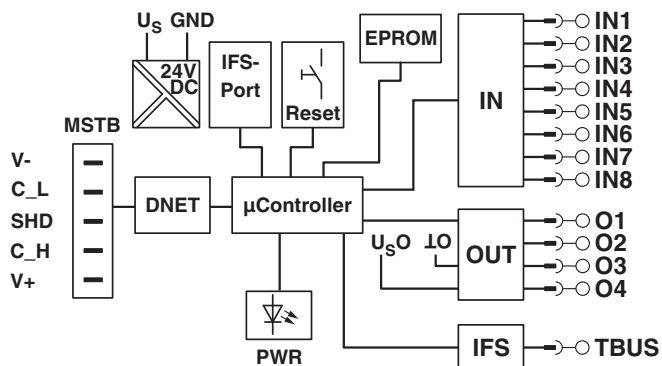

7.4 Operating elements

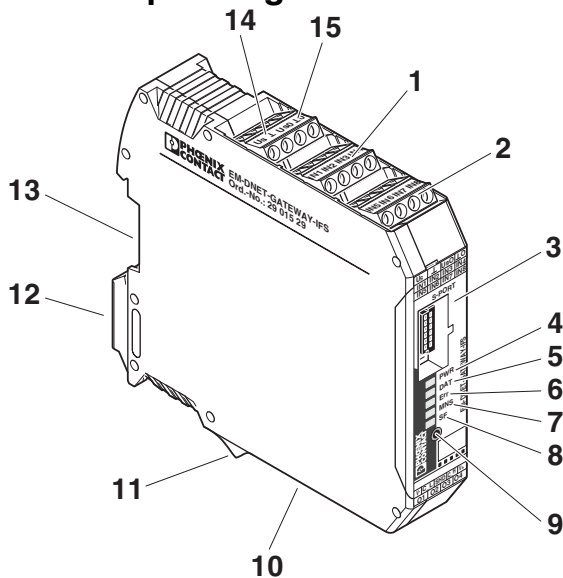



Figure 7-1 Operating and indication elements

1	Inputs IN1 to IN4	
2	Inputs IN5 to IN8	
3	S-PORT	Connection for programming adapter
4	PWR LED	Device status
5	DAT LED	IFS communication
6	ERR LED	Device or process error
7	MNS LED	Module/network status
8	SF LED	Station error
9	Button for setting the address	

## DeviceNet bus coupler for INTERFACE system devices

10	DNET interface
11	Outputs O1 to O4
12	Metal base latch for fixing on the DIN rail 
13	Connection for TBUS DIN rail connector
14	Input: Operating voltage $U_S$
15	Supply voltage for outputs O1 ... O4

### 7.5 Connection notes



#### NOTE:

The rated control voltage inputs and control voltage inputs must be operated with power supply modules according to DIN 19240 (5% residual ripple, maximum).

In order to avoid inductive or capacitive coupling of noise emissions where long control wires are used, we recommend the use of shielded conductors.

If you want to connect multiple conductors to one terminal, you must use conductors with the same conductor cross section.

#### 7.5.1 Mounting

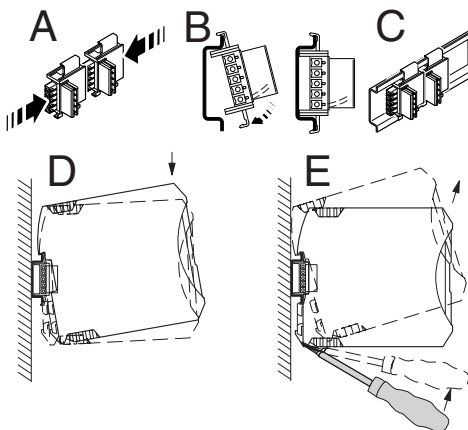

#### CAUTION:

Mounting/removal of the devices on/from the TBUS DIN rail connector may only be performed when no voltage is applied.

## CONTACTRON motor management

### TBUS DIN rail connector

The TBUS DIN rail connector makes the INTERFACE system communication and/or power supply of individual INTERFACE system devices possible.



#### NOTE:

The TBUS DIN rail connector can only be used to supply the modules if 24 V DC devices are used.

Connect the required number of TBUS DIN rail connectors (Order No. 2707437) together.

When placing the gateway onto the DIN rail, make sure that it is aligned correctly with the TBUS.

Power is supplied on the gateway or a power terminal. Observe the permissible current carrying capacity.

### 7.5.2 Bus termination

Bus termination for the DeviceNet bus is achieved with 120  $\Omega$  on the gateway on terminal blocks C\_L and C\_H.

Termination is already required with short cables and low baud rates.

In practice, termination at one end is sufficient in the case of short cables. Ideally, the bus is terminated on both ends (and only there) using 120  $\Omega$ .

### 7.6 LED status indicators

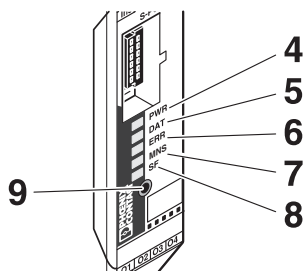

The five LEDs visualize the various operating states of the gateway.

LED	Status	Description
PWR	(Green) - <b>Device status</b>	
	Off	No supply voltage
	On	Supply voltage OK
	Flashing (1.4 Hz)	Setting the DeviceNet address
	Flashing irregularly (1.4 Hz)	Setting the transmission speed
	Flashing (2.8 Hz)	IFS address assignment

---

**DeviceNet bus coupler for INTERFACE system devices**

---

LED	Status	Description
DAT	<b>(Green) - IFS communication</b>	
	Off	No data traffic
	On	Cyclic data traffic
	Flashing (1.4 Hz)	The device is being configured.
	Flashing (2.8 Hz)	See Section "IFS-CONFSTICK(-L) memory block" on page 139
ERR	<b>(Red) - Device or process error</b>	
	Off	There are no faults.
	On	Serious internal error
	Flashing (1.4 Hz)	WARNING: Overload of the output driver.
MNS	<b>(Red/green) - Module/network status</b> (according to DeviceNet specification)	
	Off	No supply voltage or device is not online.
	On (green)	Device is ready to operate and online.
	Flashing (green)	Device is online, but connections have not been set up.
	On (red)	Critical error or critical connection error
	Flashing (red)	Error of minor importance: One or more I/O connections have been terminated due to time-out.
	Flashing (red, green)	Faulty communication. The device has detected a network access error and is in the "communication error" state.
SF	<b>(Red) - Station error</b>	
	Off	There are no faults.
	On	Internal device error or device not connected.
	Flashing (1.4 Hz)	Process error or I/O error in a device.

## 7.7 Setting and displaying the fieldbus address

- Press the button (9) for more than 4 seconds (PWR LED flashes). The gateway changes to the “fieldbus address parameterization” mode.

After releasing the button, the five LEDs indicate the current address offset.

Code					ON $\hat{=}$ <input type="checkbox"/>	Field Bus					
PWR	DAT	ERR	MNS	SF		PWR	DAT	ERR	MNS	SF	Field Bus
4	5	6	7	8		4	5	6	7	8	Address Offset
						•					16
				•		•				•	17
			•			•			•		18
			•	•		•			•	•	19
		•				•		•			20
		•		•		•		•		•	21
		•	•			•		•	•		22
		•	•	•		•		•	•	•	23
•						•	•				24
•				•		•	•			•	25
•		•				•	•		•		26
•		•	•			•	•		•	•	27
•	•					•	•	•			28
•	•			•		•	•	•		•	29
•	•	•				•	•	•	•		30
•	•	•	•			•	•	•	•	•	31

A basic address can be set using the gateway DTM (default = 0).

- Tapping on the button (9) increases the address offset up to a maximum value of “31”. Then the value is reset to “0”.
- Press the button (9) for more than 6 seconds in order to save the settings.





When not pressing the button (9) for 15 seconds, parameterization mode is quit without saving any settings.

## 7.8 Setting and displaying the transmission speed

- Press the button (9) for more than 8 seconds (PWR LED flashes). The gateway changes to the “transmission speed parameterization” mode.

After releasing the button, the five LEDs indicate the index of the transmission speed.

Code  					Index	Transmission Speed [kBaud]
PWR 4	DAT 5	ERR 6	MNS 7	SF 8		
				•	1	Automatic detection (default)
			•		2	125
			•	•	3	250
		•			4	500

- Tapping on the button (9) increases the index up to a maximum value of “4”. Then the value is reset to “1”.
- Press the button (9) for more than 6 seconds in order to save the settings.



When not pressing the button (9) for 15 seconds, parameterization mode is quit without saving any settings.

## 7.9 Setting and displaying the INTERFACE system address

- Press the button (9) for more than 12 seconds (PWR LED flashes). The gateway changes to the "IFSM addressing" mode.

After releasing the button, the five LEDs indicate the current IFSM address.

Code					ON $\approx$ $\bullet$	IFSM Address	PWR	DAT	ERR	MNS	SF	IFSM Address
PWR	DAT	ERR	MNS	SF		Address	4	5	6	7	8	Address
4	5	6	7	8								
						32	$\bullet$					16
				$\bullet$		1	$\bullet$				$\bullet$	17
			$\bullet$			2	$\bullet$			$\bullet$		18
			$\bullet$	$\bullet$		3	$\bullet$			$\bullet$	$\bullet$	19
		$\bullet$				4	$\bullet$		$\bullet$			20
		$\bullet$	$\bullet$			5	$\bullet$		$\bullet$		$\bullet$	21
		$\bullet$	$\bullet$			6	$\bullet$		$\bullet$	$\bullet$		22
		$\bullet$	$\bullet$	$\bullet$		7	$\bullet$		$\bullet$	$\bullet$	$\bullet$	23
	$\bullet$					8	$\bullet$	$\bullet$				24
	$\bullet$			$\bullet$		9	$\bullet$	$\bullet$			$\bullet$	25
	$\bullet$		$\bullet$			10	$\bullet$	$\bullet$		$\bullet$		26
	$\bullet$		$\bullet$	$\bullet$		11	$\bullet$	$\bullet$		$\bullet$	$\bullet$	27
	$\bullet$	$\bullet$				12	$\bullet$	$\bullet$	$\bullet$			28
	$\bullet$	$\bullet$		$\bullet$		13	$\bullet$	$\bullet$	$\bullet$		$\bullet$	29
	$\bullet$	$\bullet$	$\bullet$			14	$\bullet$	$\bullet$	$\bullet$	$\bullet$		30
	$\bullet$	$\bullet$	$\bullet$	$\bullet$		15	$\bullet$	$\bullet$	$\bullet$	$\bullet$	$\bullet$	31

- Press the button on the first device connected (slave). The slave accepts the address previously indicated on the gateway (master).

The gateway automatically increases the current IFSM address by "one" so that another slave can be addressed on the IFS bus.

- Press the button on the next slave.
- Address any slaves on the IFS bus in the same manner.
- Press the button (9) on the gateway for more than 6 seconds in order to save the settings. All status LEDs light up briefly.

## DeviceNet bus coupler for INTERFACE system devices

## 7.10 Technical data

Parameter	Value
<b>Supply</b>	
Rated control supply voltage $U_s$	24 V DC -20% ... +25%
Rated control supply current $I_s$	85 mA
<b>IFS interface</b>	
Transmission speed	76.8 kbps
Connection	TBUS S-PORT (connector)
<b>DeviceNet™</b>	
Transmission speed	125; 250; 500 kbaud
Connection	MSTB connector outlet
<b>General data</b>	
Test voltage	1.5 kV
Degree of protection	IP20
Ambient temperature range	Operation -25°C ... 50°C
	Storage/transport -35°C ... 80°C
Housing material	Polyamide PA, non-reinforced
Dimensions W/H/D	22.5 mm/99 mm/114.5 mm
<b>Approvals</b>	

## CONTACTRON motor management

---

## 8 RS-232 bus coupler for INTERFACE system devices



For additional information, please refer to the “EM-...-GATEWAY-IFS” quick start guide. This document can be downloaded at [phoenixcontact.net/products](http://phoenixcontact.net/products).

### 8.1 Safety notes

- Please observe the safety regulations of electrical engineering and industrial safety and liability associations.
- Disregarding these safety regulations may result in death, serious personal injury or damage to equipment.
- Startup, mounting, modifications, and upgrades may only be carried out by a skilled electrical engineer.
- Operation in a closed control cabinet according to IP54.
- Before working on the device, disconnect the power.
- During operation, parts of electrical switching devices carry hazardous voltages.
- Protective covers must not be removed when operating electrical switching devices.
- In the event of an error, replace the device immediately.
- Repairs to the device, particularly the opening of the housing, must only be carried out by the manufacturer.
- Keep the operating instructions in a safe place.

### 8.2 Short description

The EM-RS232-GATEWAY-IFS gateway (Order No. 2901526) is used for connecting devices of the INTERFACE system range to an RS-232 network.

Up to 32 devices (slaves) can be connected.

The assignment of the process data can be individually adapted to your application requirements using the gateway DTM. The DTM is also used for easy integration in an FDT environment.



The gateway DTM can be downloaded at [phoenixcontact.net/products](http://phoenixcontact.net/products).

The address is set using a button or a PC or memory stick connected to the S-PORT.

### 8.3 Block diagram

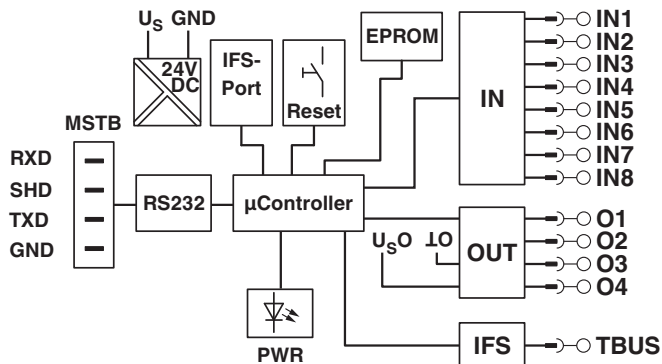

### 8.4 Operating elements

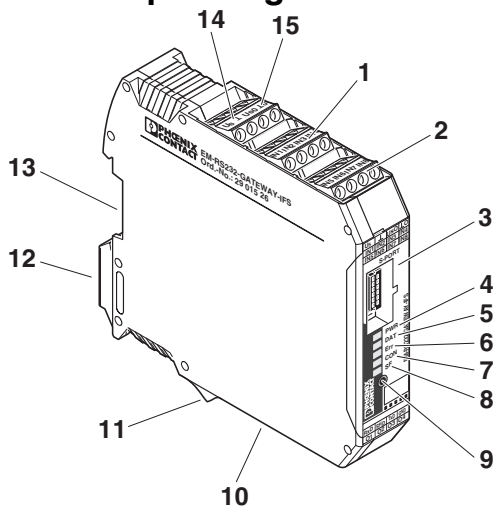



Figure 8-1 Operating and indication elements

1	Inputs IN1 to IN4	
2	Inputs IN5 to IN8	
3	S-PORT	Connection for programming adapter
4	PWR LED	Device status
5	DAT LED	IFS communication
6	ERR LED	Device or process error
7	CON LED	RS-232 communication
8	SF LED	Station error
9	Button for setting the address	
10	RS-232 interface	
11	Outputs O1 to O4	

## RS-232 bus coupler for INTERFACE system devices

12	Metal base latch for fixing on the DIN rail 
13	Connection for TBUS DIN rail connector
14	Input: Operating voltage $U_S$
15	Supply voltage for outputs O1 ... O4

## 8.5 Connection notes



**NOTE:**

The rated control voltage inputs and control voltage inputs must be operated with power supply modules according to DIN 19240 (5% residual ripple, maximum).

In order to avoid inductive or capacitive coupling of noise emissions where long control wires are used, we recommend the use of shielded conductors.

If you want to connect multiple conductors to one terminal, you must use conductors with the same conductor cross section.

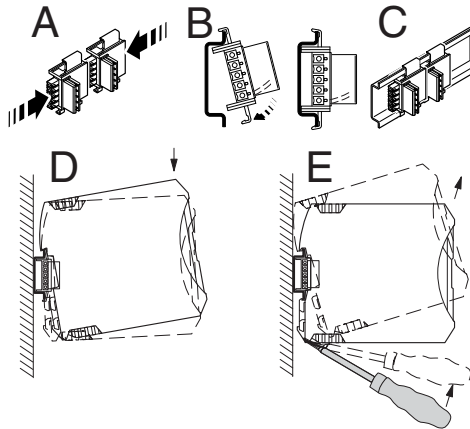
### 8.5.1 Mounting

**CAUTION:**

Mounting/removal of the devices on/from the TBUS DIN rail connector may only be performed when no voltage is applied.

#### TBUS DIN rail connector

The TBUS DIN rail connector makes the INTERFACE system communication and/or power supply of individual INTERFACE system devices possible.

**NOTE:**

The TBUS DIN rail connector can only be used to supply the modules if 24 V DC devices are used.

Connect the required number of TBUS DIN rail connectors (Order No. 2707437) together.

When placing the gateway onto the DIN rail, make sure that it is aligned correctly with the TBUS.

## CONTACTRON motor management

Power is supplied on the gateway or a power terminal. Observe the permissible current carrying capacity.

### 8.6 LED status indicators

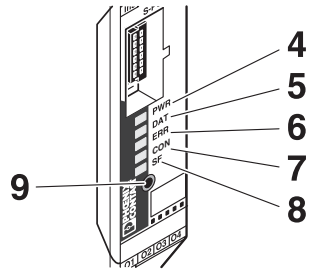

The five LEDs visualize the various operating states of the gateway.

LED	Status	Description
<b>PWR</b>	(Green) - <b>Device status</b>	
	Off	No supply voltage
	On	Supply voltage OK
	Flashing (2.8 Hz)	IFS address assignment
<b>DAT</b>	(Green) - <b>IFS communication</b>	
	Off	No data traffic
	On	Cyclic data traffic
	Flashing (1.4 Hz)	The device is being configured.
<b>ERR</b>	(Red) - <b>Device or process error</b>	
	Off	There are no faults.
	On	Serious internal error
	Flashing (1.4 Hz)	<b>WARNING:</b> Overload of the output driver.
<b>CON</b>	(Green) - <b>RS-232 communication</b>	
	Off	No communication
	On	Valid Modbus communication
	Flashing	Modbus timeout
<b>SF</b>	(Red) - <b>Station error</b>	
	Off	There are no faults.
	On	Internal device error or device not connected.
	Flashing (1.4 Hz)	Process error or I/O error in a device.

## 8.7 Setting the fieldbus address

The fieldbus address is set to 1. Like the transmission speed, the number of stop bits, and the parity, it can only be changed via the DTM.

## 8.8 Setting and displaying the INTERFACE system address

- Press the button (9) for more than 12 seconds (PWR LED flashes quickly). The gateway changes to the "IFSM addressing" mode.

After releasing the button, the five LEDs indicate the current IFSM address.

Code					IFSM Address						IFSM Address
PWR 4	DAT 5	ERR 6	CON 7	SF 8		PWR 4	DAT 5	ERR 6	CON 7	SF 8	
					32	•					16
				•	1	•				•	17
			•		2	•			•		18
			•	•	3	•			•	•	19
		•			4	•		•			20
		•		•	5	•		•		•	21
		•	•		6	•		•	•		22
		•	•	•	7	•		•	•	•	23
•					8	•	•				24
•			•		9	•	•			•	25
•			•		10	•	•		•		26
•			•	•	11	•	•		•	•	27
•	•				12	•	•	•			28
•	•			•	13	•	•	•		•	29
•	•	•			14	•	•	•	•		30
•	•	•	•		15	•	•	•	•	•	31

- Press the button on the first device connected (slave). The slave accepts the address previously indicated on the gateway (master).

The gateway automatically increases the current IFSM address by "one" so that another slave can be addressed on the IFS bus.

- Press the button on the next slave.
- Address any slaves on the IFS bus in the same manner.
- Press the button (9) on the gateway for more than 6 seconds in order to save the settings. All status LEDs light up briefly.

## CONTACTRON motor management

## 8.9 Technical data

Parameter	Value
<b>Supply</b>	
Rated control supply voltage $U_s$	24 V DC -20% ... +25%
Rated control supply current $I_s$	85 mA
<b>IFS interface</b>	
Transmission speed	76.8 kbps
Connection	TBUS S-PORT (connector)
<b>RS-232</b>	
Transmission speed	9.6 k ... 115 kbaud
Connection	MSTB connector outlet
<b>General data</b>	
Test voltage	1.5 kV
Degree of protection	IP20
Ambient temperature range	Operation -25°C ... 50°C
	Storage/transport -35°C ... 80°C
Housing material	Polyamide PA, non-reinforced
Dimensions W/H/D	22.5 mm/99 mm/114.5 mm
<b>Approvals</b>	

## 9 RS-485 bus coupler for INTERFACE system devices



For additional information, please refer to the “EM-...-GATEWAY-IFS” quick start guide. This document can be downloaded at [phoenixcontact.net/products](http://phoenixcontact.net/products).

### 9.1 Safety notes

- Please observe the safety regulations of electrical engineering and industrial safety and liability associations.
- Disregarding these safety regulations may result in death, serious personal injury or damage to equipment.
- Startup, mounting, modifications, and upgrades may only be carried out by a skilled electrical engineer.
- Operation in a closed control cabinet according to IP54.
- Before working on the device, disconnect the power.
- During operation, parts of electrical switching devices carry hazardous voltages.
- Protective covers must not be removed when operating electrical switching devices.
- In the event of an error, replace the device immediately.
- Repairs to the device, particularly the opening of the housing, must only be carried out by the manufacturer.
- Keep the operating instructions in a safe place.

### 9.2 Short Description

The EM-RS485-GATEWAY-IFS gateway (Order No. 2901527) is used for connecting devices of the INTERFACE system range to an RS-485 network.

Up to 32 devices (slaves) can be connected.

The assignment of the process data can be individually adapted to your application requirements using the gateway DTM. The DTM is also used for easy integration in an FDT environment.



The gateway DTM can be downloaded at [phoenixcontact.net/products](http://phoenixcontact.net/products).

The address is set using a button or a PC or memory stick connected to the S-PORT.

The bus must be terminated in the bus connecting cable.

CONTACTRON motor management

9.3 Block diagram

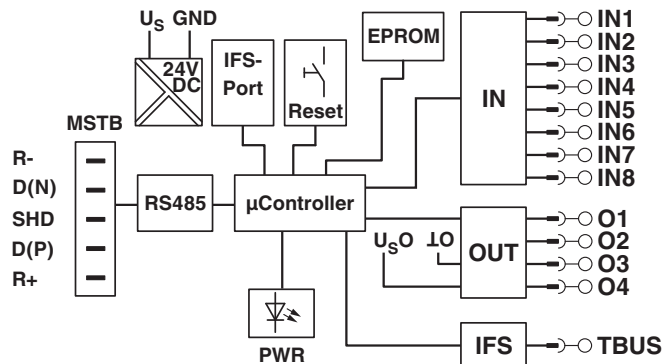

9.4 Operating elements

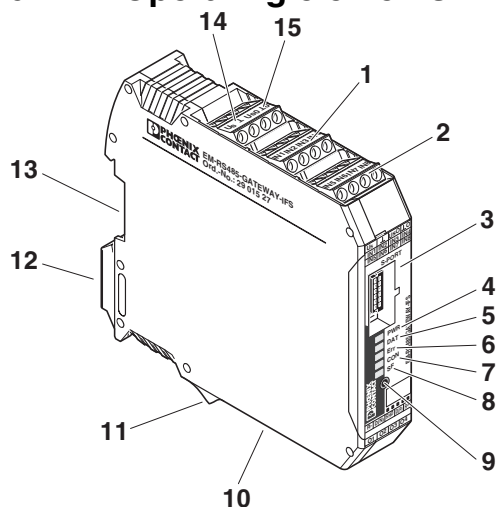



Figure 9-1 Operating and indication elements

1	Inputs IN1 to IN4	
2	Inputs IN5 to IN8	
3	S-PORT	Connection for programming adapter
4	PWR LED	Device status
5	DAT LED	IFS communication
6	ERR LED	Device or process error
7	CON LED	RS-485 communication
8	SF LED	Station error
9	Button for setting the address	
10	RS-485 interface	
11	Outputs O1 to O4	

## RS-485 bus coupler for INTERFACE system devices

12	Metal base latch for fixing on the DIN rail 
13	Connection for TBUS DIN rail connector
14	Input: Operating voltage $U_S$
15	Supply voltage for outputs O1 ... O4

## 9.5 Connection notes



**NOTE:**

The rated control voltage inputs and control voltage inputs must be operated with power supply modules according to DIN 19240 (5% residual ripple, maximum).

In order to avoid inductive or capacitive coupling of noise emissions where long control wires are used, we recommend the use of shielded conductors.

If you want to connect multiple conductors to one terminal, you must use conductors with the same conductor cross section.

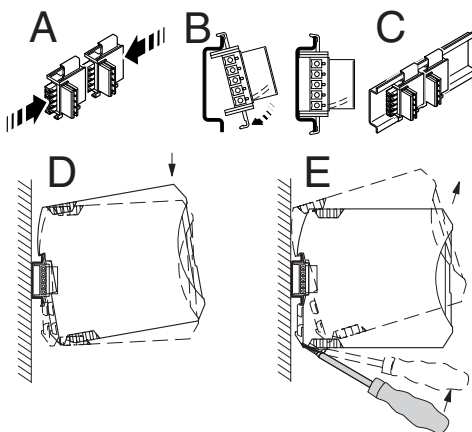
### 9.5.1 Mounting

**CAUTION:**

Mounting/removal of the devices on/from the TBUS DIN rail connector may only be performed when no voltage is applied.

#### TBUS DIN rail connector

The TBUS DIN rail connector makes the INTERFACE system communication and/or power supply of individual INTERFACE system devices possible.

**NOTE:**

The TBUS DIN rail connector can only be used to supply the modules if 24 V DC devices are used.

Connect the required number of TBUS DIN rail connectors (Order No. 2707437) together.

When placing the gateway onto the DIN rail, make sure that it is aligned correctly with the TBUS.

## CONTACTRON motor management

Power is supplied on the gateway or a power terminal. Observe the permissible current carrying capacity.

### 9.5.2 Bus termination

The device provides bus termination, an appropriate wiring should be used for this, if required. Termination is set via bridges at R- and D(N) and at R+ and D(P).

Ideally, the bus is terminated on both ends (and only there).

### 9.6 LED status indicators

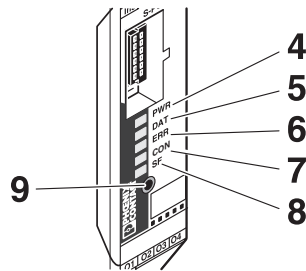

The five LEDs visualize the various operating states of the gateway.

LED	Status	Description
PWR	(Green) - <b>Device status</b>	
	Off	No supply voltage
	On	Supply voltage OK
	Flashing (1.4 Hz)	Setting the RS-485 address
	Flashing (2.8 Hz)	IFS address assignment
DAT	(Green) - <b>IFS communication</b>	
	Off	No data traffic
	On	Cyclic data traffic
	Flashing (1.4 Hz)	The device is being configured.
	Flashing (2.8 Hz)	See Section "IFS-CONFSTICK(-L) memory block" on page 139
ERR	(Red) - <b>Device or process error</b>	
	Off	There are no faults.
	On	Serious internal error
	Flashing (1.4 Hz)	<b>WARNING:</b> Overload of the output driver.
CON	(Green) - <b>RS-485 communication</b>	
	Off	No communication
	On	Valid Modbus communication
	Flashing	Modbus timeout

## RS-485 bus coupler for INTERFACE system devices

LED	Status	Description
SF	(Red) - Station error	
	Off	There are no faults.
	On	Internal device error or device not connected.
	Flashing (1.4 Hz)	Process error or I/O error in a device.

## 9.7 Setting and displaying the fieldbus address

- Press the button (9) for more than 4 seconds (PWR LED flashes). The gateway changes to the "fieldbus address parameterization" mode.

After releasing the button, the five LEDs indicate the current address offset.

Code					Field Bus Address Offset	Field Bus Address Offset					
PWR	DAT	ERR	CON	SF		PWR	DAT	ERR	CON	SF	
4	5	6	7	8		4	5	6	7	8	
					0	•					16
				•	1	•				•	17
			•		2	•			•		18
			•	•	3	•			•	•	19
		•			4	•		•			20
		•		•	5	•		•		•	21
		•	•		6	•		•	•		22
		•	•	•	7	•		•	•	•	23
	•				8	•	•				24
	•			•	9	•	•			•	25
	•		•		10	•	•		•		26
	•		•	•	11	•	•		•	•	27
	•	•			12	•	•	•			28
	•	•		•	13	•	•	•		•	29
	•	•	•		14	•	•	•	•		30
	•	•	•	•	15	•	•	•	•	•	31

A basic address can be set using the gateway DTM (default = 0).

- Tapping on the button (9) increases the address offset up to a maximum value of "31". Then the value is reset to "0".
- Press the button (9) for more than 6 seconds in order to save the settings.



When not pressing the button (9) for 15 seconds, parameterization mode is quit without saving any settings.

## 9.8 Setting and displaying the INTERFACE system address

- Press the button (9) for more than 12 seconds (PWR LED flashes quickly). The gateway changes to the "IFSM addressing" mode.

After releasing the button, the five LEDs indicate the current IFSM address.

Code					ON $\approx$ $\square$	IFSM Address						IFSM Address
PWR	DAT	ERR	CON	SF		PWR	DAT	ERR	CON	SF		IFSM Address
4	5	6	7	8		4	5	6	7	8		
						32	•					16
				•		1	•				•	17
			•			2	•			•		18
			•	•		3	•			•	•	19
		•				4	•		•			20
		•	•			5	•		•		•	21
		•	•			6	•		•	•		22
		•	•	•		7	•		•	•	•	23
	•					8	•	•				24
	•			•		9	•	•			•	25
	•		•			10	•	•		•		26
	•		•	•		11	•	•		•	•	27
	•	•				12	•	•	•			28
	•	•		•		13	•	•	•		•	29
	•	•	•			14	•	•	•	•		30
	•	•	•	•		15	•	•	•	•	•	31

- Press the button on the first device connected (slave). The slave accepts the address previously indicated on the gateway (master).

The gateway automatically increases the current IFSM address by "one" so that another slave can be addressed on the IFS bus.

- Press the button on the next slave.
- Address any slaves on the IFS bus in the same manner.
- Press the button (9) on the gateway for more than 6 seconds in order to save the settings. All status LEDs light up briefly.

## RS-485 bus coupler for INTERFACE system devices

## 9.9 Technical data

Parameter	Value
<b>Supply</b>	
Rated control supply voltage $U_s$	24 V DC -20% ... +25%
Rated control supply current $I_s$	85 mA
<b>IFS interface</b>	
Transmission speed	76.8 kbps
Connection	TBUS S-PORT (connector)
<b>RS-485</b>	
Transmission speed	9.6 k ... 115 kbaud
Connection	MSTB connector outlet
<b>General data</b>	
Test voltage	1.5 kV
Degree of protection	IP20
Ambient temperature range	Operation -25°C ... 50°C
	Storage/transport -35°C ... 80°C
Housing material	Polyamide PA, non-reinforced
Dimensions W/H/D	22.5 mm/99 mm/114.5 mm
<b>Approvals</b>	

## CONTACTRON motor management

---

## 10 Ethernet bus coupler for INTERFACE system devices



For additional information, please refer to the “EM-...-GATEWAY-IFS” quick start guide. This document can be downloaded at [phoenixcontact.net/products](http://phoenixcontact.net/products).

### 10.1 Safety notes

- Please observe the safety regulations of electrical engineering and industrial safety and liability associations.
- Disregarding these safety regulations may result in death, serious personal injury or damage to equipment.
- Startup, mounting, modifications, and upgrades may only be carried out by a skilled electrical engineer.
- Operation in a closed control cabinet according to IP54.
- Before working on the device, disconnect the power.
- During operation, parts of electrical switching devices carry hazardous voltages.
- Protective covers must not be removed when operating electrical switching devices.
- In the event of an error, replace the device immediately.
- Repairs to the device, particularly the opening of the housing, must only be carried out by the manufacturer.
- Keep the operating instructions in a safe place.

### 10.2 Short description

The EM-ETH-GATEWAY-IFS Order No. 2901988) is used for connecting devices of the INTERFACE system range to an Ethernet network using the EtherNet/IP communication protocol.

Up to 32 devices (slaves) can be connected.

The assignment of the process data can be individually adapted to your application requirements using the gateway DTM. The DTM is also used for easy integration in an FDT environment.



The gateway DTM can be downloaded at [phoenixcontact.net/products](http://phoenixcontact.net/products).

The address is set using a button or a PC or memory stick connected to the S-PORT.

### 10.3 Block diagram

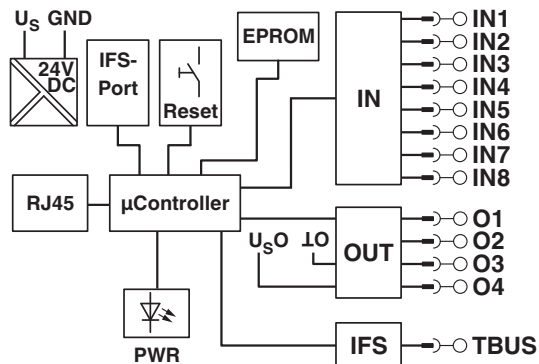

### 10.4 Operating elements

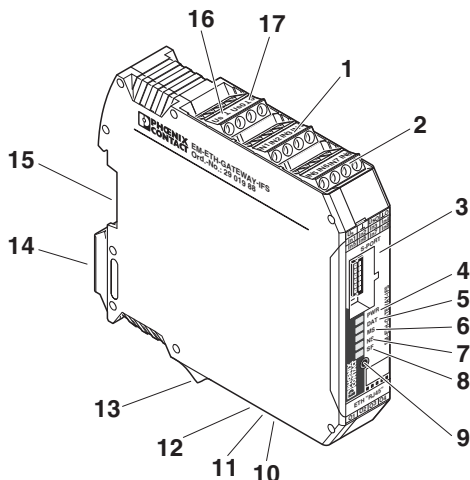



Figure 10-1 Operating and indication elements

1	Inputs IN1 to IN4	
2	Inputs IN5 to IN8	
3	S-PORT	Connection for programming adapter
4	PWR LED	Device status
5	DAT LED	IFS communication
6	MS LED	Module status
7	NS LED	Network status
8	SF LED	Station error
9	Button for setting IP mode	
10	Ethernet interface	
11	LNK LED	Link

## Ethernet bus coupler for INTERFACE system devices

12	Baud LED	Baud rate
13	Outputs O1 to O4	
14	Metal base latch for fixing on the DIN rail 	
15	Connection for TBUS DIN rail connector	
16	Input: Operating voltage $U_S$	
17	Supply voltage for outputs O1 ... O4	

## 10.5 Connection notes

**NOTE:**

The rated control voltage inputs and control voltage inputs must be operated with power supply modules according to DIN 19240 (5% residual ripple, maximum).

In order to avoid inductive or capacitive coupling of noise emissions where long control wires are used, we recommend the use of shielded conductors.

If you want to connect multiple conductors to one terminal, you must use conductors with the same conductor cross section.

## 10.5.1 Mounting

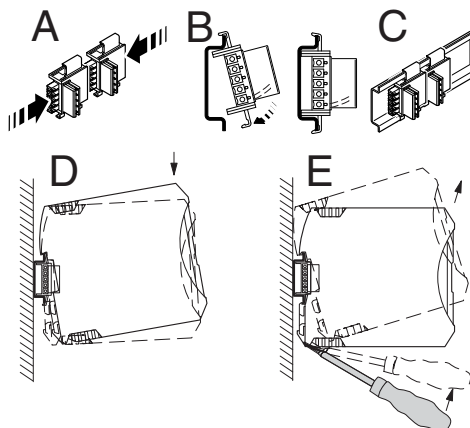
**CAUTION:**

Mounting/removal of the devices on/from the TBUS DIN rail connector may only be performed when no voltage is applied.

**TBUS DIN rail connector**

The TBUS DIN rail connector makes the INTERFACE system communication and/or power supply of individual INTERFACE system devices possible.

**NOTE:**

The TBUS DIN rail connector can only be used to supply the modules if 24 V DC devices are used.

Connect the required number of TBUS DIN rail connectors (Order No. 2707437) together.

## CONTACTRON motor management

When placing the gateway onto the DIN rail, make sure that it is aligned correctly with the TBUS.

Power is supplied on the gateway or a power terminal. Observe the permissible current carrying capacity.

### 10.6 LED status indicators

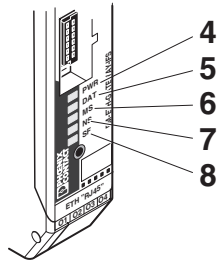

The five LEDs visualize the various operating states of the gateway.

LED	Status	Description
PWR	(Green) - <b>Device status</b>	
	Off	No supply voltage
	On	Supply voltage OK
	Flashing (1.4 Hz)	Setting IP mode
	Flashing (2.8 Hz)	IFS address assignment
DAT	(Green) - <b>IFS communication</b>	
	Off	No data traffic
	On	Cyclic data traffic
	Flashing (1.4 Hz)	The device is being configured.
	Flashing (2.8 Hz)	See Section "IFS-CONFSTICK(-L) memory block" on page 139
MS	(Green/red) - <b>Module status</b>	
	Off	No supply voltage
	Flashing (2.8 Hz) (green)	Device is not configured
	On (green)	No error
	Flashing (2.8 Hz) (red)	Repairable error/peripheral error/message, e.g., output driver overload, IFS device error, configuration error
	On (red)	Internal error - replace the device
	Flashing (2.8 Hz) (red/green)	Selftest

## Ethernet bus coupler for INTERFACE system devices

LED	Status	Description
<b>NS</b>	(Green/red) - <b>Network status</b>	
	Off	No supply voltage
	Flashing (2.8 Hz) (green)	IP address assigned, but no EtherNet/IP connection
	On (green)	EtherNet/IP connection configured, cyclic data transmission OK
	Flashing (2.8 Hz) (red)	EtherNet/IP connection timeout, connection broken
	On (red)	IP address conflict
	Flashing (2.8 Hz) (red/green)	Selftest
<b>SF</b>	(Red) - <b>Station error</b>	
	Off	There are no faults.
	On	Internal device error or device is not connected or cannot be addressed.
	Flashing (1.4 Hz)	Process error or I/O error in a device.
<b>LNK</b>	(Green) - <b>Link</b>	
	Off	No link status available
	On	Link status available
	Flashing (2.8 Hz)	Data exchange
<b>Baud</b>	(Yellow) - <b>Baud rate</b>	
	Off	10 Mbps
	On	100 Mbps

## 10.7 Setting IP mode

- Press the button (9) for more than 6 seconds (PWR LED flashes). The gateway changes to the "IP mode parameterization" mode.

After releasing the button, the five LEDs indicate the IP mode index.

Code <input type="checkbox"/> ON $\cong$ <input type="checkbox"/> •					Index	IP Mode
PWR 4	DAT 5	MS 6	NS 7	SF 8		
				•	1	Static IP address (default)
			•		2	BOOTP
			•	•	3	DHCP

- Tapping on the button (9) increases the index up to a maximum value of "4". Then the value is reset to "1".
- Press the button (9) for more than 6 seconds in order to save the settings.



When not pressing the button (9) for 15 seconds, parameterization mode is quit without saving any settings.

## 10.8 Setting and displaying the INTERFACE system address

- Press the button (9) for more than 12 seconds (PWR LED flashes quickly). The gateway changes to the "IFSM addressing" mode.

After releasing the button, the five LEDs indicate the current IFSM address.

Code					ON $\approx$ $\bullet$	IFSM						IFSM
PWR	DAT	MS	NS	SF		Address	PWR	DAT	MS	NS	SF	Address
4	5	6	7	8			4	5	6	7	8	
						32	$\bullet$					16
				$\bullet$		1	$\bullet$				$\bullet$	17
			$\bullet$			2	$\bullet$			$\bullet$		18
			$\bullet$	$\bullet$		3	$\bullet$			$\bullet$	$\bullet$	19
		$\bullet$				4	$\bullet$		$\bullet$			20
		$\bullet$	$\bullet$			5	$\bullet$		$\bullet$		$\bullet$	21
		$\bullet$	$\bullet$	$\bullet$		6	$\bullet$		$\bullet$	$\bullet$		22
		$\bullet$	$\bullet$	$\bullet$	$\bullet$	7	$\bullet$		$\bullet$	$\bullet$	$\bullet$	23
$\bullet$						8	$\bullet$	$\bullet$				24
$\bullet$				$\bullet$		9	$\bullet$	$\bullet$			$\bullet$	25
$\bullet$			$\bullet$			10	$\bullet$	$\bullet$		$\bullet$		26
$\bullet$			$\bullet$	$\bullet$		11	$\bullet$	$\bullet$		$\bullet$	$\bullet$	27
$\bullet$	$\bullet$					12	$\bullet$	$\bullet$	$\bullet$			28
$\bullet$	$\bullet$			$\bullet$		13	$\bullet$	$\bullet$	$\bullet$		$\bullet$	29
$\bullet$	$\bullet$	$\bullet$				14	$\bullet$	$\bullet$	$\bullet$	$\bullet$		30
$\bullet$	$\bullet$	$\bullet$	$\bullet$	$\bullet$		15	$\bullet$	$\bullet$	$\bullet$	$\bullet$	$\bullet$	31

- Press the button on the first device connected (slave). The slave accepts the address previously indicated on the gateway (master).

The gateway automatically increases the current IFSM address by "one" so that another slave can be addressed on the IFS bus.

- Press the button on the next slave.
- Address any slaves on the IFS bus in the same manner.
- Press the button (9) on the gateway for more than 6 seconds in order to save the settings. All status LEDs light up briefly.

## CONTACTRON motor management

## 10.9 Technical data

Parameter	Value
<b>Supply</b>	
Rated control supply voltage $U_s$	24 V DC -20% ... +25%
Rated control supply current $I_s$	85 mA
<b>IFS interface</b>	
Transmission speed	76.8 kbps
Connection	TBUS S-PORT (connector)
<b>EtherNet/IP™</b>	
Transmission speed	10/100 Mbps
Connection	MSTB connector outlet
<b>General data</b>	
Test voltage	1.5 kV
Degree of protection	IP20
Ambient temperature range	Operation: -25°C ... 50°C Storage/transport: -35°C ... 80°C
Housing material	Polyamide PA, non-reinforced
Dimensions W/H/D	22.5 mm/99 mm/114.5 mm
<b>Approvals</b>	

# 11 Modbus bus coupler for INTERFACE system devices



For additional information, please refer to the “EM-...-GATEWAY-IFS” quick start guide. This document can be downloaded at [phoenixcontact.net/products](http://phoenixcontact.net/products).

## 11.1 Safety notes

- Please observe the safety regulations of electrical engineering and industrial safety and liability associations.
- Disregarding these safety regulations may result in death, serious personal injury or damage to equipment.
- Startup, mounting, modifications, and upgrades may only be carried out by a skilled electrical engineer.
- Operation in a closed control cabinet according to IP54.
- Before working on the device, disconnect the power.
- During operation, parts of electrical switching devices carry hazardous voltages.
- Protective covers must not be removed when operating electrical switching devices.
- In the event of an error, replace the device immediately.
- Repairs to the device, particularly the opening of the housing, must only be carried out by the manufacturer.
- Keep the operating instructions in a safe place.

## 11.2 Short description

The EM-MODBUS-GATEWAY-IFS gateway (Order No. 2901528) is used for connecting devices of the INTERFACE system range to an Ethernet network using the Modbus/TCP communication protocol.

Up to 32 devices (slaves) can be connected.

The assignment of the process data can be individually adapted to your application requirements using the gateway DTM. The DTM is also used for easy integration in an FDT environment.



The gateway DTM can be downloaded at [phoenixcontact.net/products](http://phoenixcontact.net/products).

The address is set using a button or a PC or memory stick connected to the S-PORT.

### 11.3 Block diagram

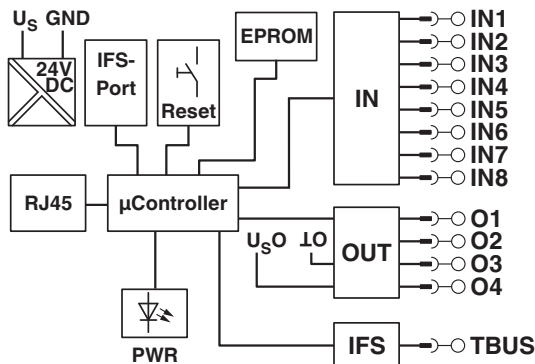

### 11.4 Operating elements

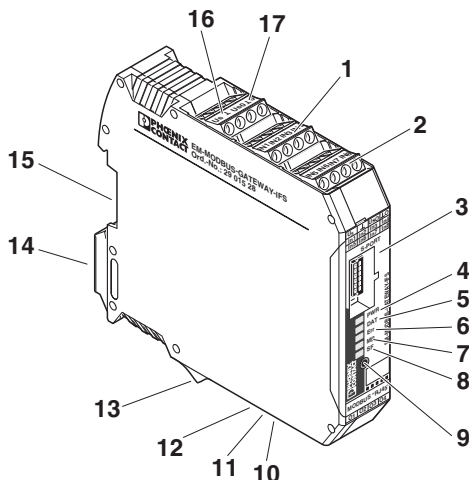



Figure 11-1 Operating and indication elements

1	Inputs IN1 to IN4	
2	Inputs IN5 to IN8	
3	S-PORT	Connection for programming adapter
4	PWR LED	Device status
5	DAT LED	IFS communication
6	ERR LED	Device or process error
7	CON LED	Modbus communication
8	SF LED	Station error
9	Button for setting IP mode	
10	Ethernet interface	
11	LNK LED	Link

## Modbus bus coupler for INTERFACE system devices

12	Baud LED	Baud rate
13	Outputs O1 to O4	
14	Metal base latch for fixing on the DIN rail 	
15	Connection for TBUS DIN rail connector	
16	Input: Operating voltage $U_S$	
17	Supply voltage for outputs O1 ... O4	

### 11.5 Connection notes



#### NOTE:

The rated control voltage inputs and control voltage inputs must be operated with power supply modules according to DIN 19240 (5% residual ripple, maximum).

In order to avoid inductive or capacitive coupling of noise emissions where long control wires are used, we recommend the use of shielded conductors.

If you want to connect multiple conductors to one terminal, you must use conductors with the same conductor cross section.

#### 11.5.1 Mounting

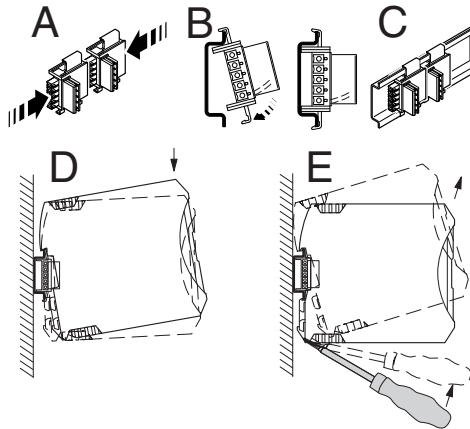

#### CAUTION:

Mounting/removal of the devices on/from the TBUS DIN rail connector may only be performed when no voltage is applied.

#### TBUS DIN rail connector

The TBUS DIN rail connector makes the INTERFACE system communication and/or power supply of individual INTERFACE system devices possible.



#### NOTE:

The TBUS DIN rail connector can only be used to supply the modules if 24 V DC devices are used.

Connect the required number of TBUS DIN rail connectors (Order No. 2707437) together.

## CONTACTRON motor management

When placing the gateway onto the DIN rail, make sure that it is aligned correctly with the TBUS.

Power is supplied on the gateway or a power terminal. Observe the permissible current carrying capacity.

### 11.6 LED status indicators

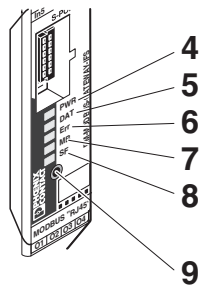

The five LEDs visualize the various operating states of the gateway.

LED	Status	Description
<b>PWR</b>	(Green) - <b>Device status</b>	
	Off	No supply voltage
	On	Supply voltage OK
	Flashing (1.4 Hz)	Setting IP mode
	Flashing (2.8 Hz)	IFS address assignment
<b>DAT</b>	(Green) - <b>IFS communication</b>	
	Off	No data traffic
	On	Cyclic data traffic
	Flashing (1.4 Hz)	The device is being configured.
	Flashing (2.8 Hz)	See Section "IFS-CONFSTICK(-L) memory block" on page 139
<b>ERR</b>	(Red) - <b>Device or process error</b>	
	Off	There are no faults.
	On	Serious internal error
	Flashing (1.4 Hz)	<b>WARNING:</b> Overload of the output driver.
<b>MB</b>	(Green) - <b>Modbus communication</b>	
	Off	No communication
	On	Valid Modbus communication
	Flashing slowly (1.4 Hz)	Reserved
	Flashing fast (2.4 Hz)	Modbus timeout

## Modbus bus coupler for INTERFACE system devices

LED	Status	Description
<b>SF</b>	(Red) - <b>Station error</b>	
	Off	There are no faults.
	On	Internal device error or device is not connected or cannot be addressed.
	Flashing (1.4 Hz)	Process error or I/O error in a device.
<b>LNK</b>	(Green) - <b>Link</b>	
	Off	No link status available
	On	Link status available
	Flashing (2.8 Hz)	Data exchange
<b>Baud</b>	(Yellow) - <b>Baud rate</b>	
	Off	10 Mbps
	On	100 Mbps

### 11.7 Setting IP mode

- Press the button (9) for more than 6 seconds (PWR LED flashes). The gateway changes to the "IP mode parameterization" mode.

After releasing the button, the five LEDs indicate the IP mode index.

Code <input type="checkbox"/> ON $\cong$ <input type="checkbox"/>					Index	IP Mode
PWR 4	DAT 5	ERR 6	MB 7	SF 8		
				•	1	Static IP address (default)
			•		2	BOOTP
			•	•	3	DHCP
		•			4	AUTO IP

- Tapping on the button (9) increases the index up to a maximum value of "4". Then the value is reset to "1".
- Press the button (9) for more than 6 seconds in order to save the settings.



When not pressing the button (9) for 15 seconds, parameterization mode is quit without saving any settings.

## 11.8 Setting and displaying the INTERFACE system address

- Press the button (9) for more than 12 seconds (PWR LED flashes quickly). The gateway changes to the "IFSM addressing" mode.

After releasing the button, the five LEDs indicate the current IFSM address.

Code					ON $\approx$ •	IFSM Address	PWR	DAT	ERR	MB	SF	IFSM Address
PWR	DAT	ERR	MB	SF		IFSM Address	PWR	DAT	ERR	MB	SF	IFSM Address
4	5	6	7	8			4	5	6	7	8	
						32	•					16
				•		1	•				•	17
			•			2	•			•		18
			•	•		3	•			•	•	19
		•				4	•		•			20
		•		•		5	•		•		•	21
		•	•			6	•		•	•		22
		•	•	•		7	•		•	•	•	23
	•					8	•	•				24
	•			•		9	•	•			•	25
	•		•			10	•	•		•		26
	•		•	•		11	•	•		•	•	27
	•	•				12	•	•	•			28
	•	•		•		13	•	•	•		•	29
	•	•	•			14	•	•	•	•		30
	•	•	•	•		15	•	•	•	•	•	31

- Press the button on the first device connected (slave). The slave accepts the address previously indicated on the gateway (master).

The gateway automatically increases the current IFSM address by "one" so that another slave can be addressed on the IFS bus.

- Press the button on the next slave.
- Address any slaves on the IFS bus in the same manner.
- Press the button (9) on the gateway for more than 6 seconds in order to save the settings. All status LEDs light up briefly.

## 11.9 Supported Modbus function codes for connection to a controller

Code	Description
FC03	Read holding registers: read multiple internal registers or output registers word by word
FC15	Write multiple coils: write multiple bits or digital outputs bit by bit or word by word

## Modbus bus coupler for INTERFACE system devices

## 11.10 Technical data

Parameter	Value
<b>Supply</b>	
Rated control supply voltage $U_s$	24 V DC -20% ... +25%
Rated control supply current $I_s$	85 mA
<b>IFS interface</b>	
Transmission speed	76.8 kbps
Connection	TBUS S-PORT (connector)
<b>Modbus/TCP</b>	
Transmission speed	10/100 Mbps
Connection	RJ45 socket
<b>General data</b>	
Test voltage	1.5 kV
Degree of protection	IP20
Ambient temperature range	Operation: -25°C ... 50°C
	Storage/transport: -35°C ... 80°C
Housing material	Polyamide PA, non-reinforced
Dimensions W/H/D	22.5 mm/99 mm/114.5 mm
<b>Approvals</b>	

## CONTACTRON motor management

---

## 12 PROFINET bus coupler for INTERFACE system devices



For additional information, please refer to the “EM-...-GATEWAY-IFS” quick start guide. This document can be downloaded at [phoenixcontact.net/products](http://phoenixcontact.net/products).

### 12.1 Safety notes

- Please observe the safety regulations of electrical engineering and industrial safety and liability associations.
- Disregarding these safety regulations may result in death, serious personal injury or damage to equipment.
- Startup, mounting, modifications, and upgrades may only be carried out by a skilled electrical engineer.
- Operation in a closed control cabinet according to IP54.
- Before working on the device, disconnect the power.
- During operation, parts of electrical switching devices carry hazardous voltages.
- Protective covers must not be removed when operating electrical switching devices.
- In the event of an error, replace the device immediately.
- Repairs to the device, particularly the opening of the housing, must only be carried out by the manufacturer.
- Keep the operating instructions in a safe place.

### 12.2 Short description

The bus coupler module (gateway) is used for connecting devices of the INTERFACE system range to a PROFINET network. Up to 32 devices (slaves) can be connected.

The assignment of the process data can be individually adapted to your application requirements using the gateway DTM. The DTM is also used for easy integration in an FDT environment.



The gateway DTM can be downloaded at [phoenixcontact.net/products](http://phoenixcontact.net/products).

The address is set using a button or a PC or memory stick connected to the S-PORT.

### 12.3 Block diagram

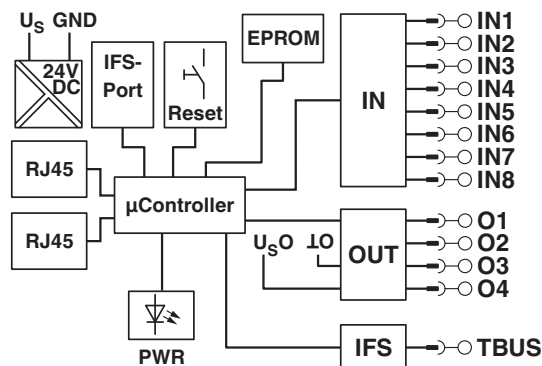

### 12.4 Operating elements

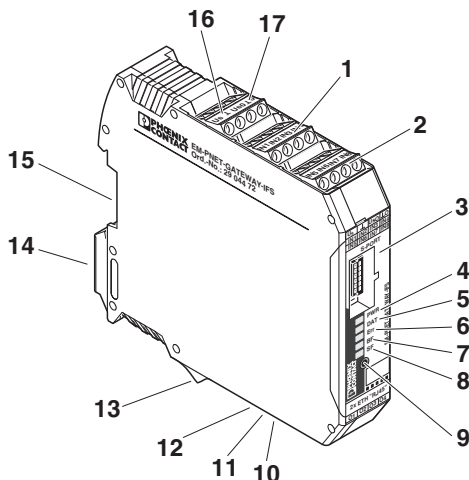



Figure 12-1 Operating and indication elements

1	Inputs IN1 to IN4	
2	Inputs IN5 to IN8	
3	S-PORT	Connection for programming adapter
4	PWR LED	Device status
5	DAT LED	IFS communication
6	LED ERR	Device or process error
7	BF LED	PROFINET communication
8	SF LED	Station error
9	Button for setting IP mode	
10	2 x RJ45 interface	
11	LNK LED	Link

## PROFINET bus coupler for INTERFACE system devices

12	Baud LED	Baud rate
13	Outputs O1 to O4	
14	Metal base latch for fixing on the DIN rail 	
15	Connection for TBUS DIN rail connector	
16	Input: Operating voltage $U_S$	
17	Supply voltage for outputs O1 ... O4	

### 12.5 Connection notes



#### NOTE:

Operate the rated control voltage inputs and control voltage inputs using SELV power units that supply output current of maximum 8 A.

In order to avoid inductive or capacitive coupling of noise emissions where long control wires are used, we recommend the use of shielded conductors.

If you want to connect multiple conductors to one terminal, you must use conductors with the same conductor cross section.

#### 12.5.1 Mounting

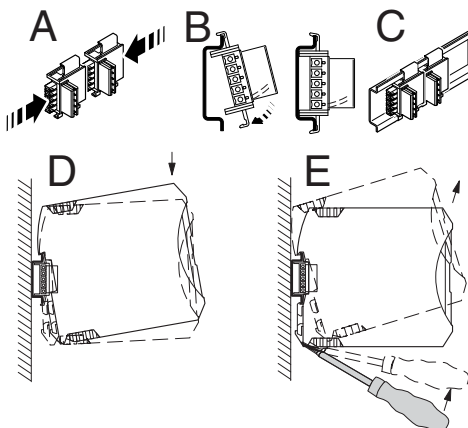

#### CAUTION:

Mounting/removal of the devices on/from the TBUS DIN rail connector may only be performed when no voltage is applied.

#### TBUS DIN rail connector

The TBUS DIN rail connector makes the INTERFACE system communication and/or power supply of individual INTERFACE system devices possible.



#### NOTE:

The TBUS DIN rail connector can only be used to supply the modules if 24 V DC devices are used.

Connect the required number of TBUS DIN rail connectors (Order No. 2707437) together.

## CONTACTRON motor management

When placing the gateway onto the DIN rail, make sure that it is aligned correctly with the TBUS.

Power is supplied on the gateway or a power terminal. Observe the permissible current carrying capacity.

### 12.6 LED status indicators

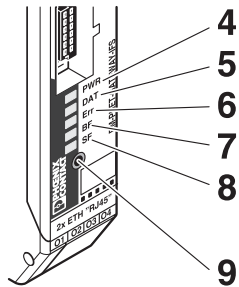

The five LEDs visualize the various operating states of the gateway.

LED	Status	Description
<b>PWR</b>	<b>(Green) - Device status</b>	
	Off	No supply voltage
	On	Supply voltage OK
	Flashing (1.4 Hz)	Setting IP mode
	Flashing (2.8 Hz)	IFS address assignment
<b>DAT</b>	<b>(Green) - IFS communication</b>	
	Off	No data traffic
	On	Cyclic data traffic
	Flashing (1.4 Hz)	The device is being configured.
	Flashing (2.8 Hz)	See Section "IFS-CONFSTICK(-L) memory block" on page 139
<b>ERR</b>	<b>(Red) - Device or process error</b>	
	Off	There are no faults.
	On	Serious internal error
	Flashing (1.4 Hz)	<b>WARNING:</b> Overload of the output driver.
<b>BF</b>	<b>(Green) - PROFINET communication</b>	
	Off	No communication
	On (red)	Fault in the communication controller or no physical connection to the PROFINET network
	Flashing fast (2.4 Hz)	PROFINET timeout

## PROFINET bus coupler for INTERFACE system devices

LED	Status	Description
<b>SF</b>	(Red) - <b>Station error</b>	
	Off	There are no faults.
	On	Internal device error or device is not connected or cannot be addressed.
	Flashing (1.4 Hz)	Process error or I/O error in a device.
<b>LNK</b>	(Green) - <b>Link</b>	
	Off	No link status available
	On	Link status available
	Flashing (2.8 Hz)	Data exchange
<b>Baud</b>	(Yellow) - <b>Baud rate</b>	
	Off	10 Mbps
	On	100 Mbps



You can set the communication parameters such as IP address, subnet mask, and default gateway via the Dynamic Configuration Protocol (DCP).

## 12.7 Setting and displaying the INTERFACE system address

- Press the button (9) for more than 12 seconds (PWR LED flashes quickly). The gateway changes to the "IFSM addressing" mode.

After releasing the button, the five LEDs indicate the current IFSM address.

Code					ON $\equiv$ <input type="checkbox"/>	IFSM Address					IFSM Address
PWR	DAT	ERR	BF	SF		PWR	DAT	ERR	BF	SF	IFSM Address
4	5	6	7	8		4	5	6	7	8	
						•					16
				•		•				•	17
			•			•			•		18
			•	•		•			•	•	19
		•				•		•			20
		•		•		•		•		•	21
		•	•			•		•	•		22
		•	•	•		•		•	•	•	23
•						•	•				24
•				•		•	•			•	25
•		•				•	•		•		26
•		•	•			•	•		•	•	27
•	•					•	•	•			28
•	•			•		•	•	•		•	29
•	•	•				•	•	•	•		30
•	•	•	•			•	•	•	•	•	31

- Press the button on the first device connected (slave). The slave accepts the address previously indicated on the gateway (master).

The gateway automatically increases the current IFSM address by "one" so that another slave can be addressed on the IFS bus.

## CONTACTRON motor management

- Press the button on the next slave.
- Address any slaves on the IFS bus in the same manner.
- Press the button (9) on the gateway for more than 6 seconds in order to save the settings. All status LEDs light up briefly.

## 12.8 Technical data

Parameter	Value
<b>Supply</b>	
Rated control supply voltage $U_s$	24 V DC -20% ... +25%
Rated control supply current $I_S$ plus load current of the outputs	85 mA
<b>Digital inputs</b>	
Rated actuating voltage $U_c$	24 V DC $\pm 20\%$
Rated actuating current $I_c$	3 mA
Protective circuit	Protection against polarity reversal, surge protection
<b>Switching outputs</b>	
Rated output voltage $U_{sO}$	24 V DC
Residual voltage	1 V
Maximum switching current per output	500 mA
Protective circuit	Parallel protection against polarity reversal, observe fuse protection with 8 A F fuse, maximum
<b>IFS interface</b>	
Transmission speed	76.8 kbps
Connection	DIN rail connector S-PORT (connector)
<b>PROFINET</b>	
Transmission speed	10/100 Mbps
Number of connections	2
Connection	RJ45 socket
<b>General data</b>	
Degree of protection	IP20
Pollution degree	2
Overvoltage category	III
Ambient temperature range	Operation: -35°C ... 50°C Storage/transport: -35°C ... 80°C
Housing material	Polyamide PA, non-reinforced
Dimensions W/H/D	22.5 mm/99 mm/114.5 mm
Standards/regulations	EN 61131-2

## 13 IFS-CONFSTICK(-L) memory block

The IFS-CONFSTICK-L multifunctional memory block (Order No. 2901103) is used for easy storage and backup of configuration data.

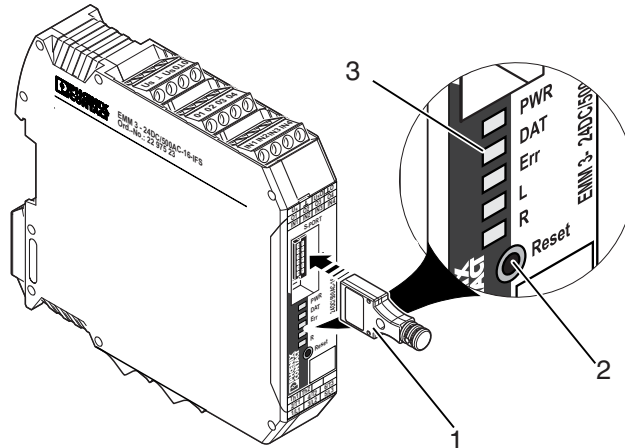

Figure 13-1 Operating and indication elements

- 1 IFS-CONFSTICK(-L)
- 2 Button
- 3 Status LEDs

### 13.1 Writing the device configuration to the IFS-CONFSTICK(-L)

1. Make sure that the IFS-CONFSTICK(-L) has not yet been inserted in the device.
2. Press the reset button on the EMM ... IFS.
3. Insert the IFS-CONFSTICK(-L) in the device within 4 seconds.  
The copying of configuration and parameterization data is started.  
The DAT LED flashes while saving.
4. Wait until the DAT LED has gone out.  
Saving has been completed.
5. Remove the IFS-CONFSTICK(-L) from the device.



If an error is detected while saving or subsequently checking the data, the DAT and ERR LEDs flash simultaneously.

## 13.2 Loading the device configuration on the EMM...IFS

There are two ways of loading configuration and parameterization data.

### 13.2.1 Brand new device

1. Insert the IFS-CONFSTICK(-L) in the device.
2. Switch on the device.  
Transfer of the configuration and parameterization data starts automatically and the DAT LED flashes.  
Following transfer, the device is marked "already configured".
3. Remove the IFS-CONFSTICK(-L) from the device.
4. The next time the supply voltage is switched on, the new configuration will be valid.



If an error is detected while saving or subsequently checking the data, the DAT and ERR LEDs flash simultaneously.  
The device then enters the safe state, because it is not configured.

### 13.2.2 Configured device



It is not possible to load the configuration and parameterization data while the motor is running.

1. Insert the IFS-CONFSTICK(-L) in the device.  
The configuration and parameterization data is checked automatically.
2. If another configuration is detected on the device, the DAT and ERR LEDs flash alternately.
3. Press the reset button within 6 seconds.



If the reset button is not pressed within 6 seconds, the DAT and ERR LEDs flash simultaneously (the ERR LED flashes at double the frequency) in order to indicate that the configuration has not been saved to the device.

4. Copying from the IFS-CONFSTICK(-L) to the device starts automatically.  
The DAT LED flashes while saving.
5. The next time the supply voltage is switched on, the new configuration will be valid.



If the configuration and parameterization data is invalid or an error has been detected, the DAT and ERR LEDs flash simultaneously and the data is not saved to the device.

### 13.3 Technical data

<b>IFS-CONFSTICK-L</b>	<b>2901103</b>
<b>General data</b>	
Memory used	2 MB
Rewritability	100,000 cycles
Dimensions (width x height x depth)	16.5 mm x 6.5 mm x 39.5 mm
Weight	4.5 g, approximately
<b>Ambient conditions</b>	
Ambient temperature (operation)	-25°C ... 60°C
Ambient temperature (storage/transport)	-25°C ... 60°C

## CONTACTRON motor management

---

## 14 TBUS DIN rail connector



Devices may only be mounted on/removed from the TBUS connector when the power is switched off.

When using the TBUS DIN rail connector (Order No. 2707437) for INTERFACE system communication and/or the voltage supply of the individual modules, connect the required number of TBUS connectors (A) together and push them onto the DIN rail (B).

When attaching the module to the DIN rail, make sure that it is aligned correctly with the TBUS connector (C).

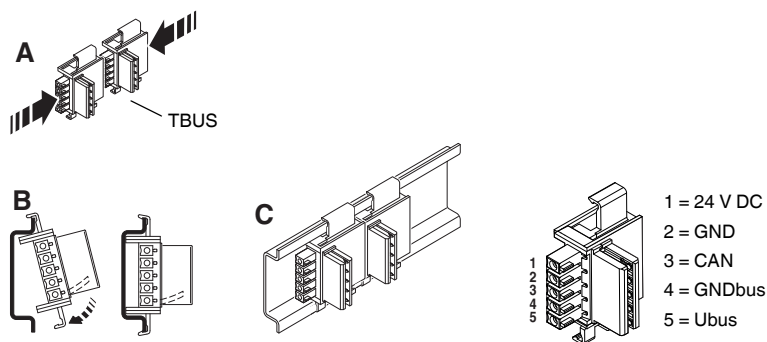

Figure 14-1 TBUS DIN rail connector

The voltage supply can be provided at the device or using the system power supply via the TBUS connector. The voltage supply can be provided at any EMM device, fieldbus module or using the system power supply via the TBUS connector.

A connection can be established between two DIN rail connectors using MINI COMBICON connectors: MC 1,5/5-ST-3,81 (socket, 1803604); IMC 1,5/5-ST-3,81 (pin, 1857919). The maximum cable length is 10 m. Use shielded cables.

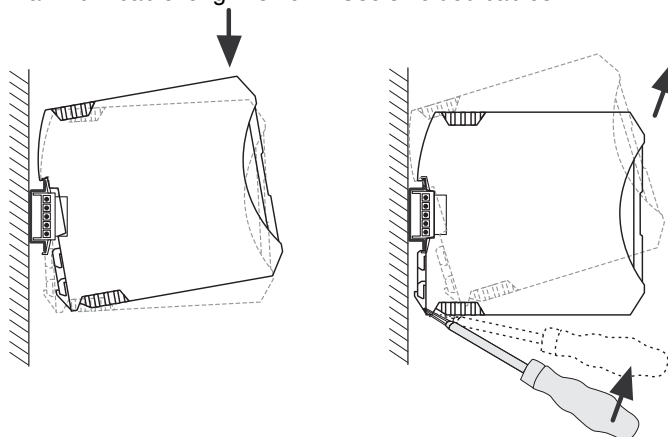

Figure 14-2 Mounting/removal

## 14.1 Technical data

<b>TBUS DIN rail connector</b>	<b>2707437</b>
<b>General data</b>	
Housing material	Polyamide PA
Insulation material group	I
Overvoltage category	III
Pollution degree	3
Rated voltage	125 V
Rated surge voltage	2.5 kV
Maximum load current	8 A
Dimensions (width x height x depth)	30 mm x 20 mm x 37 mm

## 15 Current transformer selection guide

This selection guide can be used to find a suitable current transformer for EMM... electronic motor management modules from Phoenix Contact.

The tables refer to current transformers in the PACT measurement and control range from Phoenix Contact. You can also use current transformers from other manufacturers, which meet the requirements described:

Table 15-1 Basic current transformer requirements

Requirement	Value
Impulse withstand voltage	6 kV
Primary voltage	1000 V
Overvoltage category	III
Standard	EN 50178, IEC 60044-1
Transformer type	Linear measuring transformer
Temperature range	-25°C ... +70°C
Transformation ratio	$TR = \frac{I_{pn}}{I_{sn}}$
Primary rated current $I_{pn}$	Application-specific
Secondary rated current $I_{sn}$	5 A
EMM internal resistance	0.02 Ω
Error, system, sum	EMM errors + transformer errors
Transformer class	1

### Example:

Motor type 132

Nominal motor current at 380/400 V AC = 11.5 A

When using **Ex e motors**, the transformer must be able to measure 8 times the nominal motor current, therefore an 80 A transformer must be used (e.g., PACT MCR...80).

Motor protection is implemented using the electronically simulated bimetal function of the EMM... Current transformers can process up to 120% of the primary nominal current.

When using standard motors, i.e., **non-Ex e motors**, a 50 A transformer can be used, through which the primary conductor can be passed four times.

Motor protection is implemented using the motor management of the EMM...

CONTACTRON motor management

### 15.1 Three-phase motor at a rotational frequency of 3000 rpm

EMM...IFS	EMM...16-IFS	Motor type	Motor power	Nominal motor current		Motor protection using the electronic bimetal function for Ex e motors and non-Ex e motors		Motor protection provided by motor management for non-Ex e motors	
				at 380/400 V		Current transformer at 380/400 V	Current transformer at 500 V	Current transformer at 380/400 V (4 Durchf. means that the conductor is passed through the transformer 4 times)	Current transformer at 500 V (4 Durchf. means that the conductor is passed through the transformer 4 times)
				P [kW]	I <sub>N</sub> [A]				
	✓	71	0.55	1.36	1.03				
	✓	80	0.75	1.86	1.42				
	✓	80	1.1	2.65	2.0				
	✓	90	1.5	3.4	2.6				
	✓	90	2.2	4.9	3.7				
	✓	100	3	6.3	4.8				
	✓	112	4	7.8	5.9				
✓	✓	132	5.5	11.5	8.7	PACT MCR... 80	PACT MCR... 60	PACT MCR... 50_4_Durchf.	PACT MCR... 50_5_Durchf.
✓	✓	132	7.5	15.7	12	PACT MCR...125	PACT MCR... 80	PACT MCR... 50_3_Durchf.	PACT MCR... 50_4_Durchf.
✓		160	11	22	16.9	PACT MCR...150	PACT MCR...125	PACT MCR... 50_2_Durchf.	PACT MCR... 50_3_Durchf.
✓		160	15	29.5	22.5	PACT MCR...200	PACT MCR...150	PACT MCR... 50	PACT MCR... 50_2_Durchf.
✓		160	18.5	35.5	27	PACT MCR...250	PACT MCR...200	PACT MCR... 50	PACT MCR... 50_2_Durchf.
✓		180	22	42.5	32.5	PACT MCR...300	PACT MCR...250	PACT MCR... 50	PACT MCR... 50
✓		200	30	56	43	PACT MCR...400	PACT MCR...300	PACT MCR... 60	PACT MCR... 50
✓		200	37	70	53	PACT MCR...500	PACT MCR...400	PACT MCR... 75	PACT MCR... 50
✓		225	45	83	63	PACT MCR...600	PACT MCR...500	PACT MCR...100	PACT MCR... 75
✓		250	55	102	78	PACT MCR...750	PACT MCR...600	PACT MCR...100	PACT MCR... 75
✓		280	75	136	103	PACT MCR...1000	PACT MCR...750	PACT MCR...150	PACT MCR...100
✓		280	90	162	123	PACT MCR...1250	PACT MCR...1000	PACT MCR...200	PACT MCR...125
✓		315	110	198	150	PACT MCR...1500	PACT MCR...1000	PACT MCR...200	PACT MCR...150
✓		315	132	240	182	PACT MCR...1600	PACT MCR...1250	PACT MCR...250	PACT MCR...200
✓		315	160	285	217	PACT MCR...2000	PACT MCR...1500	PACT MCR...300	PACT MCR...250

## 15.2 Three-phase motor at a rotational frequency of 1500 rpm

EMM...IFS	EMM...16-IFS	Motor type	Motor power P [kW]	Nominal motor current at 380/400 V		Nominal motor current at 500 V		Motor protection using the electronic bimetal function for Ex e motors and non-Ex e motors		Motor protection provided by motor management for non-Ex e motors	
				I <sub>N</sub> [A]	I <sub>N</sub> [A]	Current transformer at 380/400 V	Current transformer at 500 V	Current transformer at 380/400 V (4 Durchf. means that the conductor is passed through the transformer 4 times)	Current transformer at 500 V (4 Durchf. means that the conductor is passed through the transformer 4 times)		
				I <sub>N</sub> [A]	I <sub>N</sub> [A]						
	✓	71	0.37	1.14	-						
	✓	80	0.55	1.55	1.18						
	✓	80	0.75	1.95	1.48						
	✓	90	1.1	2.75	2.1						
	✓	90	1.5	3.6	2.75						
	✓	100	2.2	5.1	3.9						
	✓	112	3	7.3	5.6						
	✓	132	4	8.6	6.6						
✓	✓	132	5.5	11.4	8.7	PACT MCR... 80	PACT MCR... 60	PACT MCR... 50_4_Durchf.	PACT MCR... 50_5_Durchf.		
✓		160	7.5	15.5	11.8	PACT MCR...125	PACT MCR... 80	PACT MCR... 50_3_Durchf.	PACT MCR... 50_4_Durchf.		
✓		160	11	22.5	17.1	PACT MCR...150	PACT MCR...125	PACT MCR... 50_2_Durchf.	PACT MCR... 50_3_Durchf.		
✓		160	15	30	23	PACT MCR...200	PACT MCR...200	PACT MCR... 50	PACT MCR... 50_2_Durchf.		
✓		180	18.5	37	28	PACT MCR...250	PACT MCR...200	PACT MCR... 50	PACT MCR... 50		
✓		200	22	43	32.5	PACT MCR...300	PACT MCR...250	PACT MCR... 50	PACT MCR... 50		
✓		200	30	58	43.5	PACT MCR...400	PACT MCR...300	PACT MCR... 60	PACT MCR... 50		
✓		225	37	72	54.5	PACT MCR...500	PACT MCR...400	PACT MCR... 75	PACT MCR... 60		
✓		250	45	85	65	PACT MCR...600	PACT MCR...500	PACT MCR...100	PACT MCR... 75		
✓		280	55	103	78	PACT MCR...750	PACT MCR...600	PACT MCR...100	PACT MCR... 80		
✓		280	75	146	111	PACT MCR...1000	PACT MCR...750	PACT MCR...150	PACT MCR...125		
✓		315	90	173	132	PACT MCR...1250	PACT MCR...1000	PACT MCR...200	PACT MCR...150		
✓		315	110	198	150	PACT MCR...1500	PACT MCR...1000	PACT MCR...200	PACT MCR...150		
✓		315	132	235	179	PACT MCR...1600	PACT MCR...1250	PACT MCR...250	PACT MCR...200		

CONTACTRON motor management

### 15.3 Three-phase motor at a rotational frequency of 1000 rpm

EMM...IFS	EMM...16-IFS	Motor type	Motor power	Nominal motor current		Motor protection using the electronic bimetal function for Ex e motors and non-Ex e motors		Motor protection provided by motor management for non-Ex e motors	
				Nominal motor current at 380/400 V	Nominal motor current at 500 V	Current transformer at 380/400 V	Current transformer at 500 V	Current transformer at 380/400 V	Current transformer at 500 V
				P [kW]	I <sub>N</sub> [A]	I <sub>N</sub> [A]	(4 Durchf. means that the conductor is passed through the transformer 4 times)	(4 Durchf. means that the conductor is passed through the transformer 4 times)	
	✓	80	0.37	1.2	-				
	✓	80	0.55	1.8	1.35				
	✓	90	0.75	2.4	1.8				
	✓	90	1.1	3.4	2.55				
	✓	100	1.5	4.5	3.4				
	✓	112	2.2	5.8	4.4				
	✓	132	3	6.8	5.2				
	✓	132	4	9.3	7				
✓	✓	132	5.5	12.4	9.4	PACT MCR...100	PACT MCR... 75	PACT MCR... 50_4_Durchf.	PACT MCR... 50_5_Durchf.
✓		160	7.5	16.3	12.4	PACT MCR...125	PACT MCR...100	PACT MCR... 50_3_Durchf.	PACT MCR... 50_4_Durchf.
✓		160	11	23.5	17.8	PACT MCR...200	PACT MCR...125	PACT MCR... 50_2_Durchf.	PACT MCR... 50_2_Durchf.
✓		180	15	31	23.5	PACT MCR...250	PACT MCR...200	PACT MCR... 50	PACT MCR... 50_2_Durchf.
✓		200	18.5	37.5	28.5	PACT MCR...250	PACT MCR...200	PACT MCR... 50	PACT MCR... 50
✓		200	22	45	34	PACT MCR...300	PACT MCR...250	PACT MCR... 50	PACT MCR... 50
✓		225	30	61	46.5	PACT MCR...500	PACT MCR...400	PACT MCR... 60	PACT MCR... 50
✓		250	37	77	59	PACT MCR...600	PACT MCR...400	PACT MCR... 75	PACT MCR... 60
✓		280	45	84	64	PACT MCR...600	PACT MCR...500	PACT MCR...100	PACT MCR... 75
✓		280	55	102	78	PACT MCR...750	PACT MCR...600	PACT MCR...100	PACT MCR... 80
✓		315	75	146	111	PACT MCR...1000	PACT MCR...750	PACT MCR...150	PACT MCR...125
✓		315	90	174	132	PACT MCR...1250	PACT MCR...1000	PACT MCR...200	PACT MCR...150
✓		315	110	212	161	PACT MCR...1500	PACT MCR...1250	PACT MCR...250	PACT MCR...200

### 15.4 Three-phase motor at a rotational frequency of 750 rpm

EMM...-IFS	EMM...16-IFS	Motor type	Motor power	Nominal motor current at 380/400 V		Nominal motor current at 500 V		Motor protection using the electronic bimetal function for Ex e motors and non-Ex e motors		Motor protection provided by motor management for non-Ex e motors	
				P [kW]	I <sub>N</sub> [A]	I <sub>N</sub> [A]	Current transformer at 380/400 V	Current transformer at 500 V	Current transformer at 380/400 V (4 Durchf. means that the conductor is passed through the transformer 4 times)	Current transformer at 500 V (4 Durchf. means that the conductor is passed through the transformer 4 times)	
				I <sub>N</sub> [A]	I <sub>N</sub> [A]						
	✓	80	0.25	1.0	-						
	✓	90	0.37	1.5	1.14						
	✓	90	0.55	2	1.54						
	✓	100	0.75	2.5	1.9						
	✓	100	1.1	3.45	2.6						
	✓	112	1.5	4.35	3.3						
	✓	132	2.2	5.9	4.5						
	✓	132	3	7.9	6						
✓	✓	160	4	9.7	7.4	PACT MCR... 75	PACT MCR... 50	PACT MCR... 50_5_Durchf.	PACT MCR... 50_6_Durchf.		
✓	✓	160	5.5	13.6	10.3	PACT MCR...100	PACT MCR... 75	PACT MCR... 50_3_Durchf.	PACT MCR... 50_4_Durchf.		
✓		160	7.5	18	13.6	PACT MCR...150	PACT MCR...100	PACT MCR... 50_2_Durchf.	PACT MCR... 50_3_Durchf.		
✓		180	11	24	18.2	PACT MCR...200	PACT MCR...125	PACT MCR... 50_2_Durchf.	PACT MCR... 50_2_Durchf.		
✓		200	15	32.5	24.5	PACT MCR...250	PACT MCR...200	PACT MCR... 50	PACT MCR... 50_2_Durchf.		
✓		225	18.5	41.5	31.5	PACT MCR...300	PACT MCR...250	PACT MCR... 50	PACT MCR... 50		
✓		225	22	48.5	37	PACT MCR...400	PACT MCR...250	PACT MCR... 50	PACT MCR... 50		
✓		250	30	63	48	PACT MCR...500	PACT MCR...400	PACT MCR... 75	PACT MCR... 50		
✓		280	37	75	57	PACT MCR...500	PACT MCR...400	PACT MCR... 75	PACT MCR... 60		
✓		280	45	95	72	PACT MCR...700	PACT MCR...500	PACT MCR...100	PACT MCR... 75		
✓		315	55	109	83	PACT MCR...800	PACT MCR...600	PACT MCR...125	PACT MCR... 80		
✓		315	75	151	115	PACT MCR...1250	PACT MCR...800	PACT MCR...150	PACT MCR...125		
✓		315	90	181	138	PACT MCR...1250	PACT MCR...1000	PACT MCR...200	PACT MCR...150		

## 15.5 Recommended restart time

Recommended restart time following bimetal response when using Ex e motors:

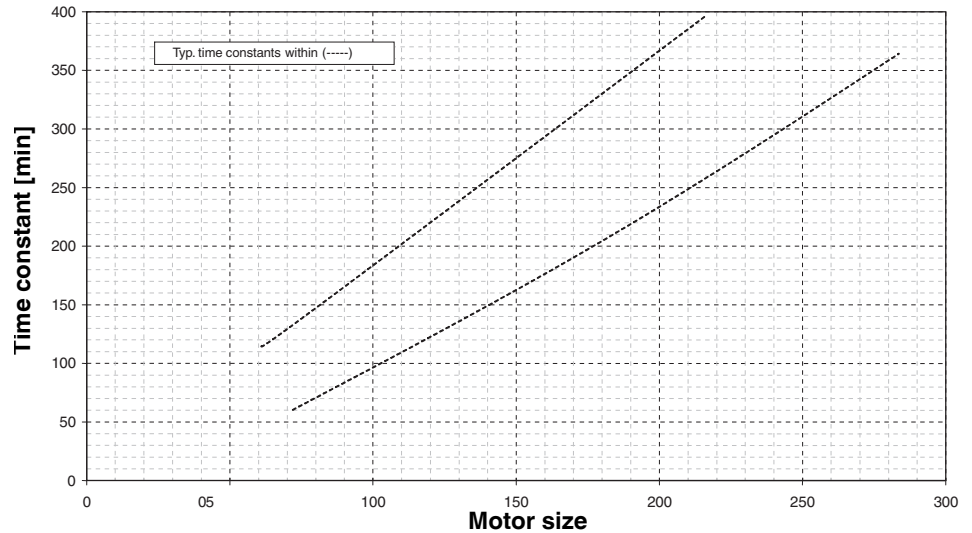

Figure 15-1 Recommended restart time



A restart time of 120 minutes can be achieved with the CONTACTRON-DTM-IFS.

---

## 16 CONTACTRON-DTM-IFS device drivers

The DTM (Device Type Manager) comprises all functions, the structure, the parameterization, and the GUI (graphical user interface) including a help system for a specific field device or maybe a device range. The DTM is installed on the PC as a program, but can only be started from a container or the frame application, e.g., IFS-Conf.

In addition to the device DTMs, there are also DTMs for communication devices, such as PROFIBUS DP controller boards, HART modems or gateway devices.

The devices in the CONTACTRON EMM... product range (electronic motor management) product range from Phoenix Contact can be used to switch, measure, warn, protect, monitor, and evaluate. The electronic management module offers all the familiar advantages of real power monitoring. Drives of any size are now started or reversed with separate contactors. In this way, not only the motor but the complete system is protected against damage by overload or underload.

Depending on the gateway used, all communication for parameterization, operation, and monitoring is possible in online mode via PROFIBUS DP-V1, CANopen®, DeviceNet™, PROFINET, Modbus/TCP, EtherNet/IP™, RS-232, and RS-485. The bus device is simply integrated in the control system via the DTM (Device Type Manager).

The Phoenix Contact CONTACTRON-DTM-IFS can also be integrated in other FDT containers, such as:

- PACTware
- FieldCare from Endress+Hauser
- fdtCONTAINER from M&M
- SmartVision from ABB

## CONTACTRON motor management

### 16.1 System requirements

#### 16.1.1 Supported operating systems

- MS Windows 2000 with Service Pack 4
- MS Windows XP
- MS Windows Vista
- MS Windows 7

#### 16.1.2 Hardware requirements

Hardware requirements		
CPU	Pentium III 1 GHz, (2 GHz recommended)	
RAM	Min. 1 Gbyte, 2 Gbytes recommended	Windows Vista, Windows 7
	Min. 512 Mbytes, 1 Gbyte recommended	Windows XP, Windows 2000 SP4
Hard disk space	500 Mbyte free memory space	
CD-ROM drive	Yes	
Interfaces	1 x USB 2.0	
Monitor	Min. SVGA, resolution of 1024 x 768 pixels, SXGA, resolution of 1280 x 1024 recommended	
Operator panels	Keyboard, mouse	

#### 16.1.3 Software requirements

Software requirements for CONTACTRON motor management	
.Net Framework	Version 1.1
.Net Framework	Version 1.1 SP1
.Net Framework	Version 2.0
Windows Installer	Version 3.1
Internet browser	MS Internet Explorer Version 6.0 or later Mozilla Firefox Version 3.5 or later

Designation	Description
FDT Container	IFS-CONF M&M
CONTACTRON-DTM-IFS	DTM devices for integrating the EMM module in the FDT container

### 16.1.4 Programming adapters/cables

Designation	Description	Order No.
IFS-USB-PROG-ADAPTER	Programming adapter for configuring Phoenix Contact INTERFACE modules with 12-pos. S-PORT interface	2811271
IFS-USB-DATACABLE	Data cable for communication between industrial PC and Phoenix Contact devices with the 12-pos. IFS data port	2320500
IFS-TCP-PROG-ADAPTER	RJ45 network cable for communication between industrial PC and Phoenix Contact devices	-

### 16.1.5 Configuration package

Designation	Description	Order No.
MM-CONF-SET	The configuration package contains the following components: CONTACTRON-DTM-IFS IFS-USB-PROG-ADAPTER	2297992

## 16.2 Connecting the programming adapter

Use the IFS-USB-PROG-ADAPTER programming adapter (Order No 281 1271) or IFS-USB-DATACABLE (Order No. 2320500) for configuring Phoenix Contact INTERFACE modules with 12-pos. S-PORT interface.

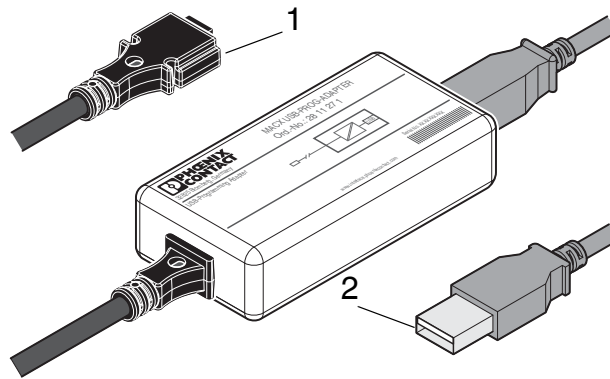

Figure 16-1 IFS-USB-PROG-ADAPTER

- 1 S-PORT connector
- 2 USB connector

### 16.2.1 Connection notes



**WARNING:** Risk of injury

The programming adapter must not be used in potentially explosive areas.  
Do not use the programming adapter if you suspect that it is damaged.



The adapter may only be used to program supported Phoenix Contact INTERFACE devices. Check the documentation for your device to see whether the programming adapter is compatible.

You must install the configuration software required for your device prior to initial startup. Observe the relevant device documentation for this purpose.

### 16.2.2 Connection to the PC

Connect the programming adapter to a free USB connection on your PC using the USB cable provided.

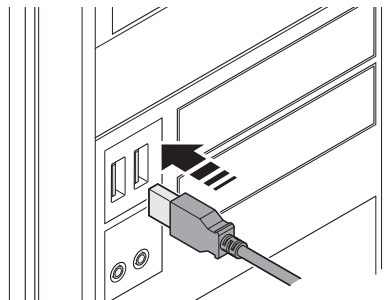

Figure 16-2 Connection to the PC

### 16.2.3 Connection to the device

On the device, connect the programming adapter to the 12-pos. S-PORT interface.

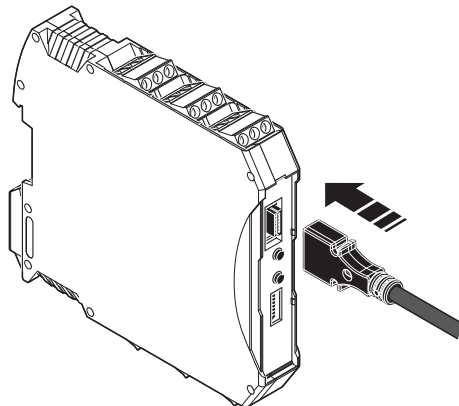

Figure 16-3 Connection to the device

**NOTE:** Potential damage to cable

Position the programming adapter so that no strain is placed on the connection on the device.



To simultaneously parameterize up to 32 EMM devices, which are connected to a gateway via the TBUS, connect the IFS-USB-PROG-ADAPTER (Order No. 2811271) or the IFS-USB-DATACABLE (Order No. 2320500) data cable to the gateway.

## 16.3 Software installation

1. Download the “IFS-CONF-SUITE-INTERFACE Setup” software from the URL [phoenixcontact.net/products](http://phoenixcontact.net/products)
2. Run the installation file by double-clicking it.
3. Follow the instructions in the installation program until it comes to selecting the software to be installed.

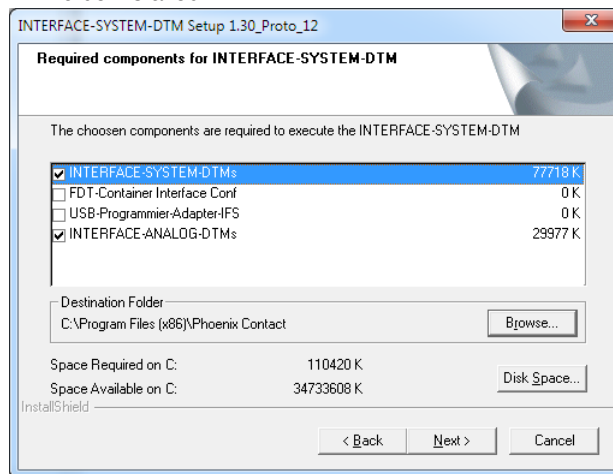

Figure 16-4 Installation wizard

All options are installed as standard. The following descriptions stipulate that Phoenix Contact's own FDT frame application (FDT container IFS-Conf) is installed and used.



Only Phoenix Contact DTMs can be integrated into Phoenix Contact's own FDT frame application (FDT container IFS-Conf). In addition, available FDT frame applications, such as M&M (see [phoenixcontact.net/products](http://phoenixcontact.net/products)), are able to manage any DTMs from various manufacturers.

## CONTACTRON motor management

### 16.3.1 Starting the application

1. Start the application by double-clicking the icon.



Figure 16-5 Software icon

## 16.4 Software configuration

### 16.4.1 Initial startup

When starting the IFS-Conf application for the first time, you must set up an administrator. Additional users can be set up within the application under “Tools, User Administration”.



Select the “Use Windows login for this user” checkbox if you wish to log in as standard with this user name each time the application starts. In this case, you will not be prompted for your password when the application starts, as authentication has already taken place through the Windows login. This setting is not recommend for an administrator.

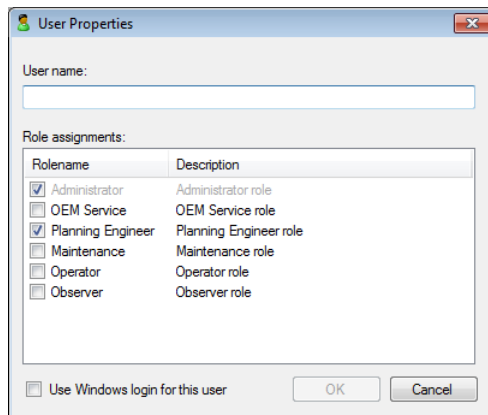

Figure 16-6 Creating a user when starting the software for the first time

## 16.4.2 Transferring CONTACTRON-DTM-IFS to catalog management

After you have created the user, DTM catalog management opens automatically.

1. Click on “Search for installed DTMs”.

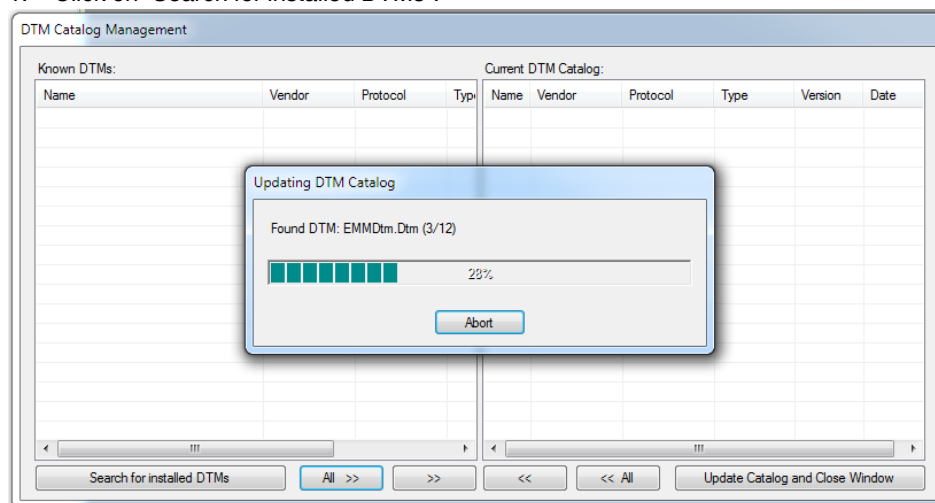

Figure 16-7 Searching for known DTMs

2. Any DTMs found on the system are then displayed in the left-hand table under “Known DTMs”. Transfer all desired DTMs to the current DTM catalog. To do this, proceed as follows:
3. Select the DTM or several DTMs simultaneously and click on the “>>” button or transfer all the DTMs by clicking on “All >>”.

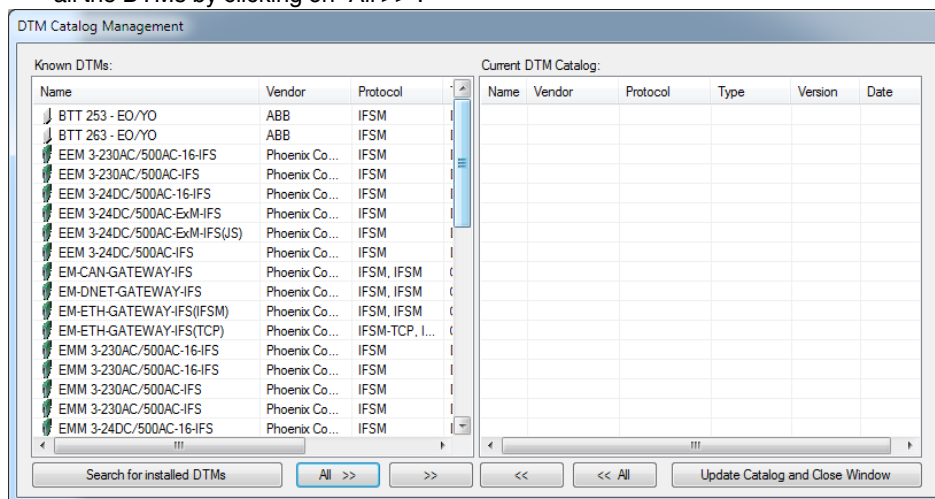

Figure 16-8 Displaying known DTMs

## CONTACTRON motor management

All desired DTMs are displayed in the current DTM catalog. If you want to transfer additional DTMs at a later time, follow the same procedure.

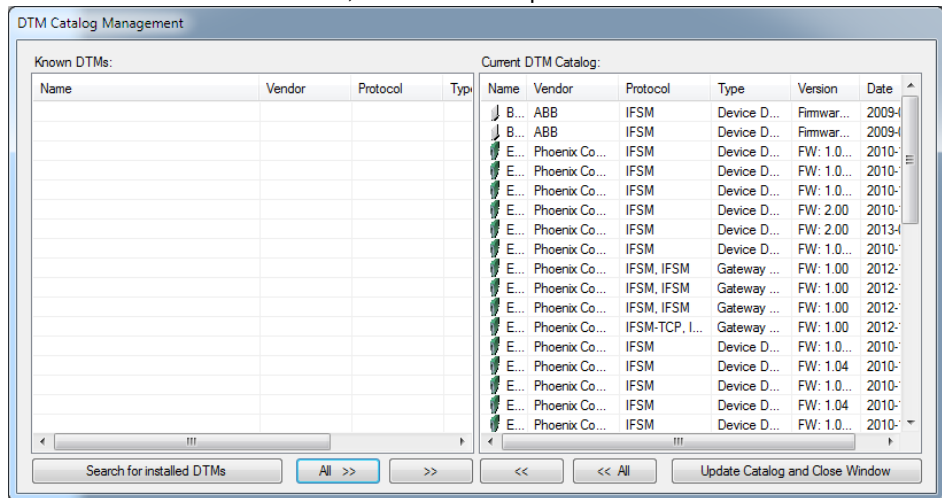

Figure 16-9 DTM Catalog Management

- Click the “Close” button. All DTMs are now prepared for use in the current DTM catalog. Catalog management is closed.

### 16.4.3 Topology scan

- Press the “IFSMGwChannel” button to manually start the topology scan wizard and search for connected devices.

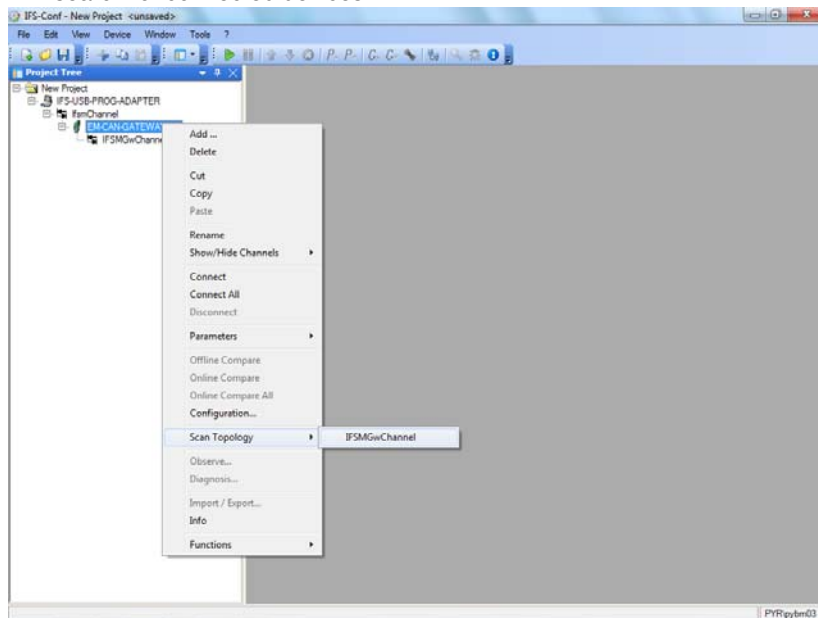

Figure 16-10 Topology scan

The device search is in progress.

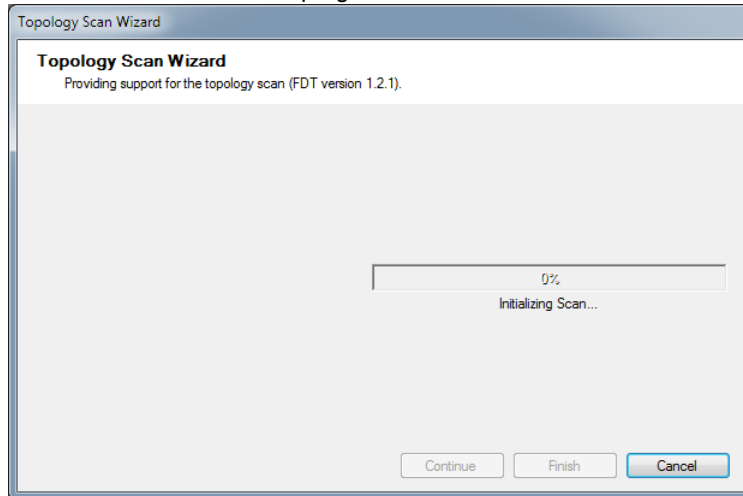

Figure 16-11 Topology Scan Wizard

Any modules found are displayed in the project tree.

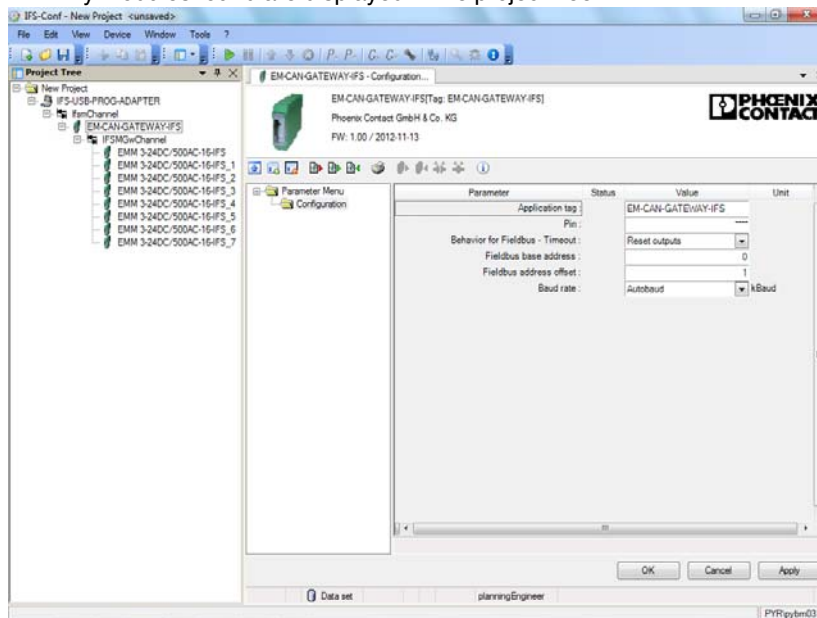

Figure 16-12 Project tree

#### 16.4.4 Connecting several devices via an IFS gateway

If several devices, which have not been assigned a unique IFS address, are connected to a gateway via the TBUS, you can cancel the topology scan, as the devices connected to the gateway are not initially displayed in the project tree.

## CONTACTRON motor management

### 16.4.5 Functions

Under the “Functions” menu item, you can manage devices connected to the gateway and configure process data.

#### 16.4.5.1 Device management

1. In order to identify all the devices on the bus, open the gateway device management by right-clicking the mouse on “Functions, Device management”.

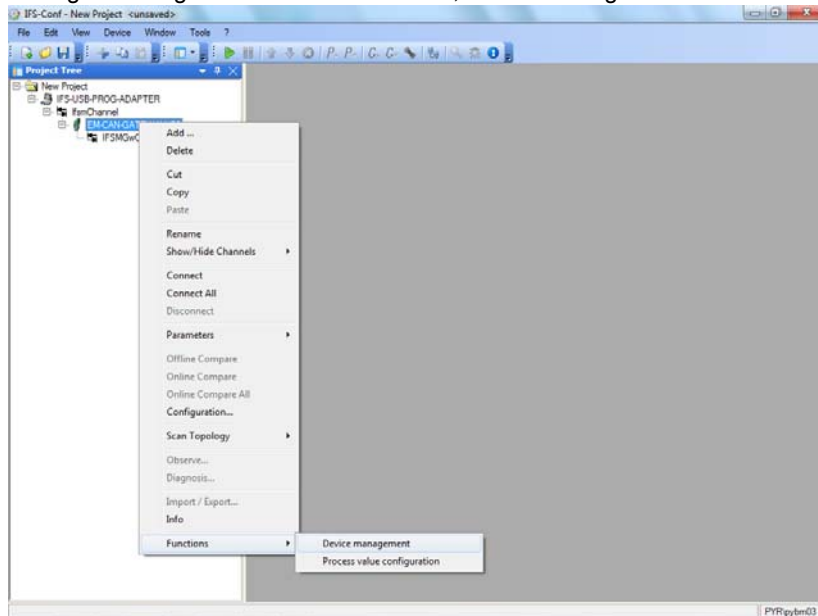

Figure 16-13 Opening device management

2. Press the “Connect” button to establish a connection to the gateway.

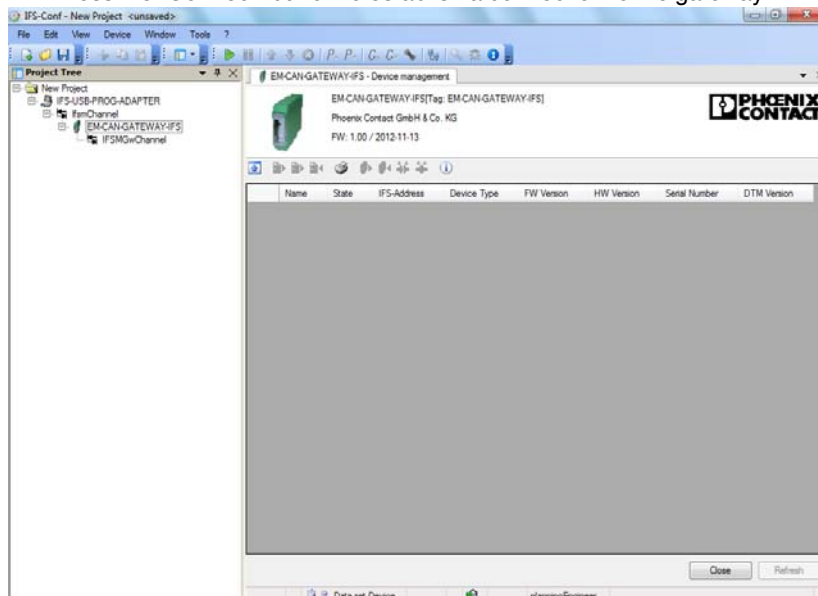

Figure 16-14 Device management

Following connection, the button in the project tree is highlighted green.

- Then click on the “Refresh” button to read the hardware structure.

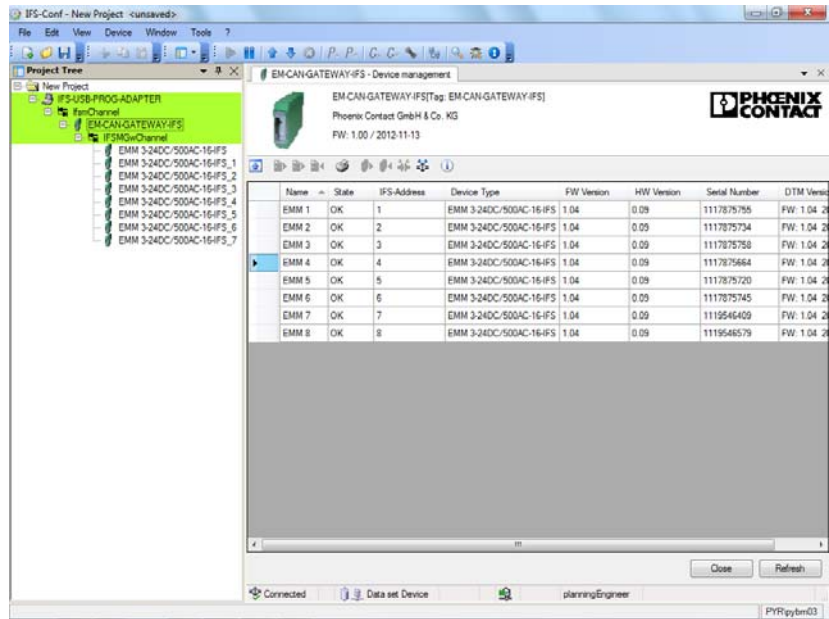

Figure 16-15 Reading the hardware structure

- Assign an IFS address and name to each connected device and then write this information to the devices. To do so, right-click on the gateway in the project tree and in the parameters menu on “Download All Parameters”.

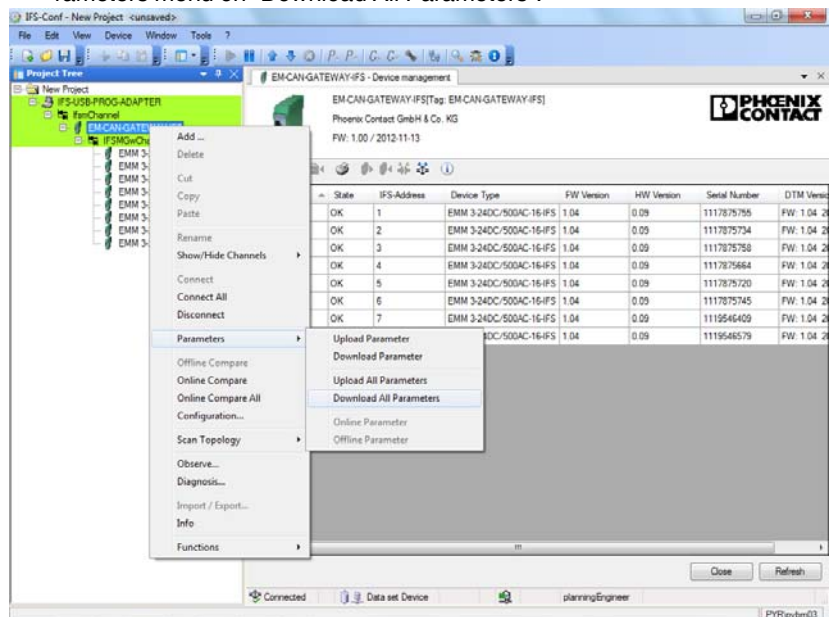

Figure 16-16 Downloading parameters

The devices are then highlighted green. If addresses have already been assigned to IFS bus devices, you merely need to change the device names.

## CONTACTRON motor management

### 16.4.6 Options

1. The simplest way to assign each device is to select an individual name for every device under “Tools, Options”.

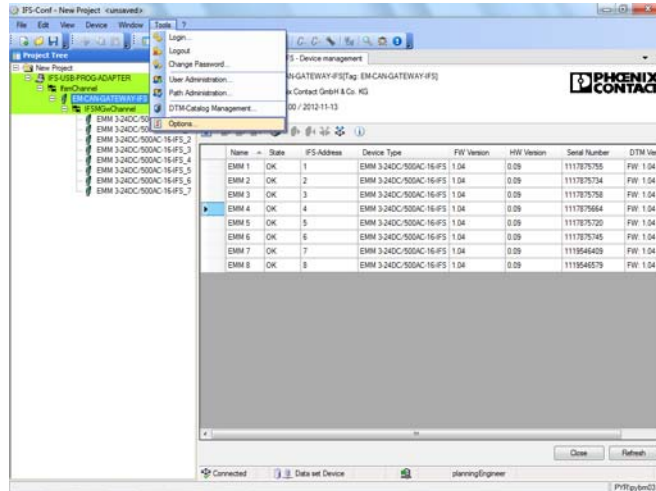

Figure 16-17 Selecting “Options”

2. Selecting “Individual Name (Fdt: Tag)”.

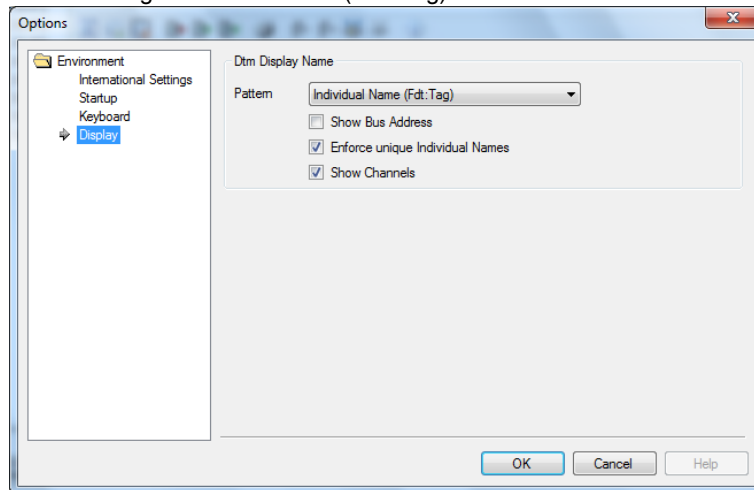

Figure 16-18 “Individual Name” options

## 16.5 Process data configuration

The process data configuration determines which data should be exchanged between the gateway and the control level. In addition to control signals and status messages as inputs, this data can also be measured values of connected devices. Process data can be selected by means of drag and drop.

1. To do so, open the process data configuration by right-clicking on the gateway in the project tree under “Functions, Process value configuration”.

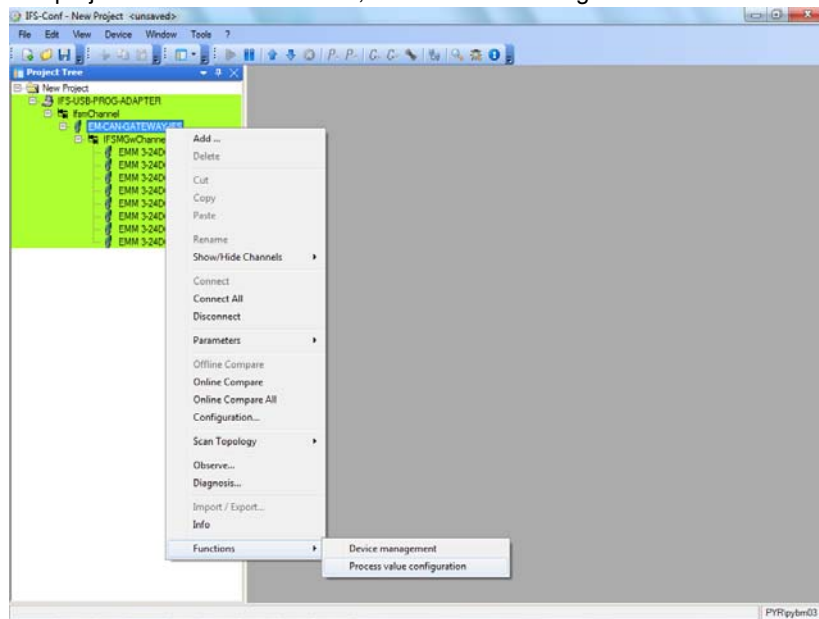

Figure 16-19 Process data configuration

## CONTACTRON motor management

### 16.5.1 Definition of process data

Here you can view and define the process data that can be assigned to each device.

1. Select the device.

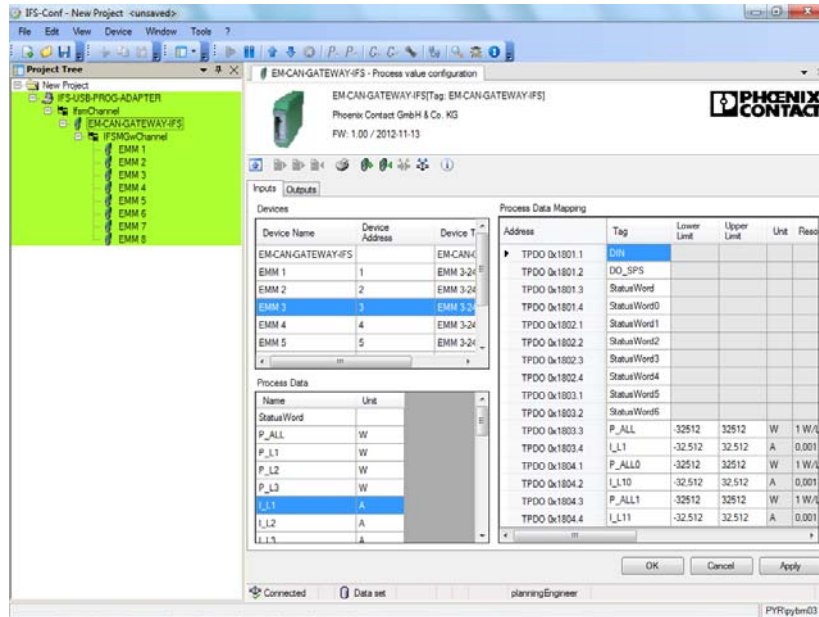

Figure 16-20 Device selection

2. Select either "Inputs" or "Outputs".
3. Select the process data required by "double-clicking" it.
4. Click the "Apply" button to apply the process data to the project.

## 16.5.2 Downloading process data

1. To write project data to the modules, right-click with the mouse on the gateway in the project tree and select "Parameters, Download All Parameters".

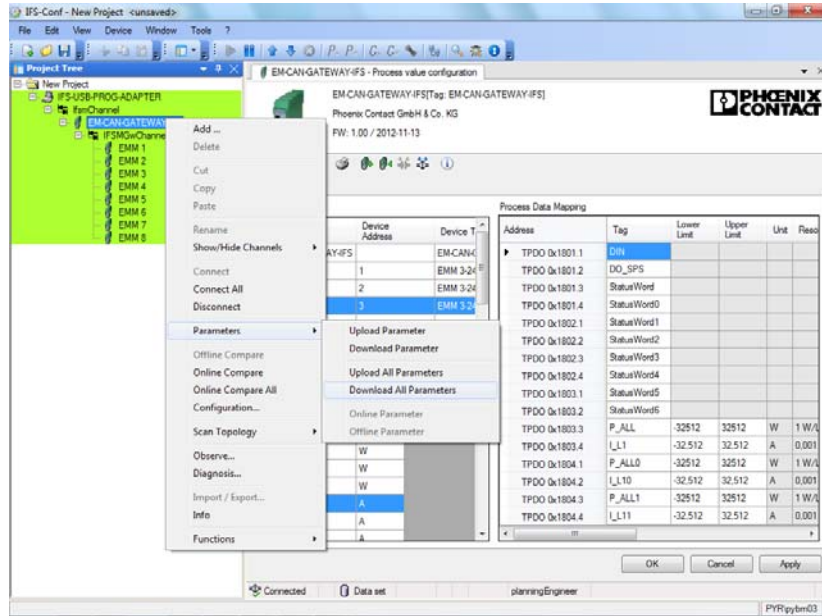

Figure 16-21 Writing project data to the modules

## CONTACTRON motor management

### 16.6 Monitoring dialog box

You can display the cyclically updated process data values of the connected IFS devices, which were assigned in the process data configuration.

The data is displayed in a hexadecimal, binary, and decimal format. The units of the measured values are also displayed.

1. Right-click on the gateway and then on “Observe”.

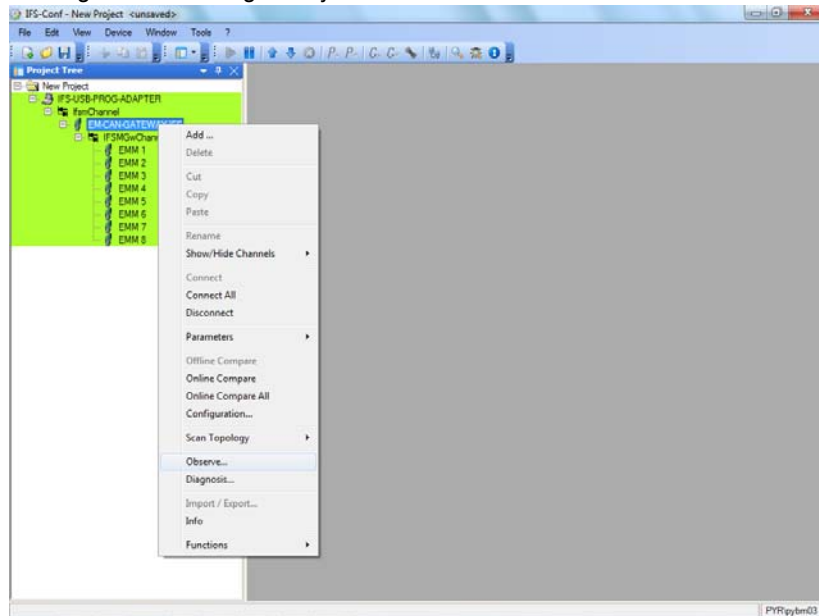

Figure 16-22 Monitoring

The defined process data is displayed with the corresponding measured values.

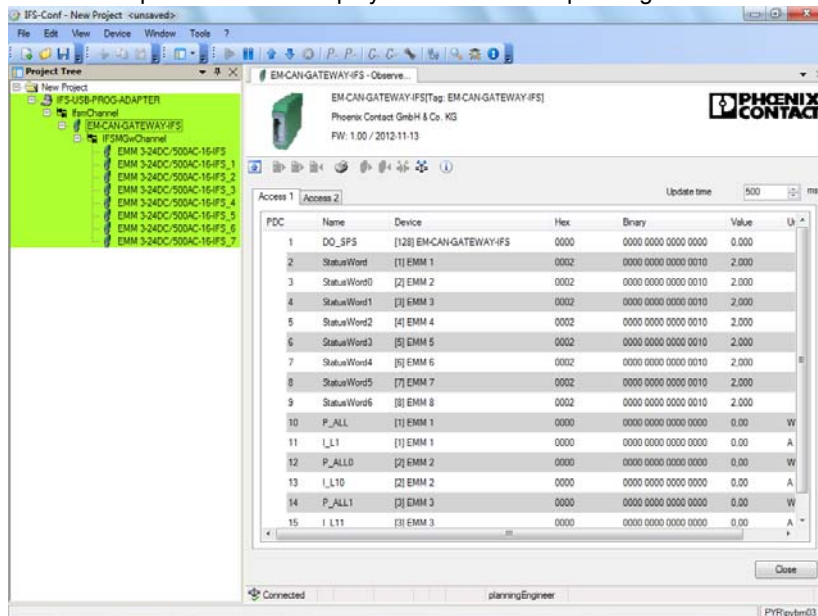

Figure 16-23 Displaying process values in the “Observe” window

## 16.7 Settings

1. To set the gateway properties, such as fieldbus address and baud rate, right-click on the gateway and then left-click on “Configuration”.
2. Set the required properties, such as baud rate and fieldbus address. For optimum performance, we recommend defining a fixed baud rate and not selecting Autobaud.
3. Click the “Apply” button to apply the data to the project.
4. This procedure applies to all gateways.

CONTACTRON motor management

16.7.1 CAN gateway EM-CAN-GATEWAY-IFS

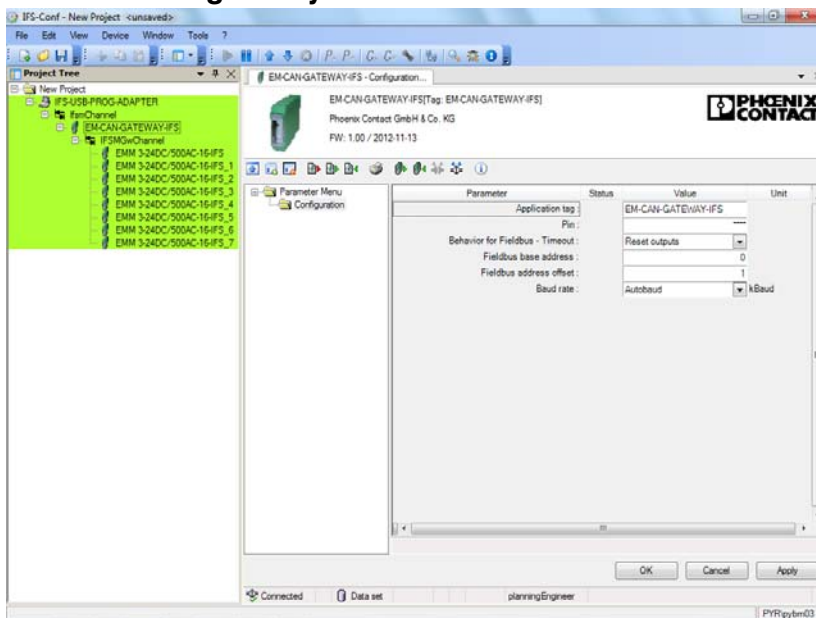

Figure 16-24 CAN gateway settings

Parameter	Selection	Interval	Program side
Application tag	– Max. 32 characters	–	EM-CAN-GATEWAY-IFS
Pin	– Min: 0 – Max: 9999	–	0000
Behavior for fieldbus timeout	– Reset outputs – Maintain last state	–	Reset outputs
Fieldbus base address	– Min: 0 – Max: 255	1	0
Fieldbus address offset	– Min: 0 – Max: 255	1	10
Baud rate	– Autobaud – 10 – 20 – 50	–	Autobaud

### 16.7.2 Ethernet gateway EM-ETH-GATEWAY-IFS

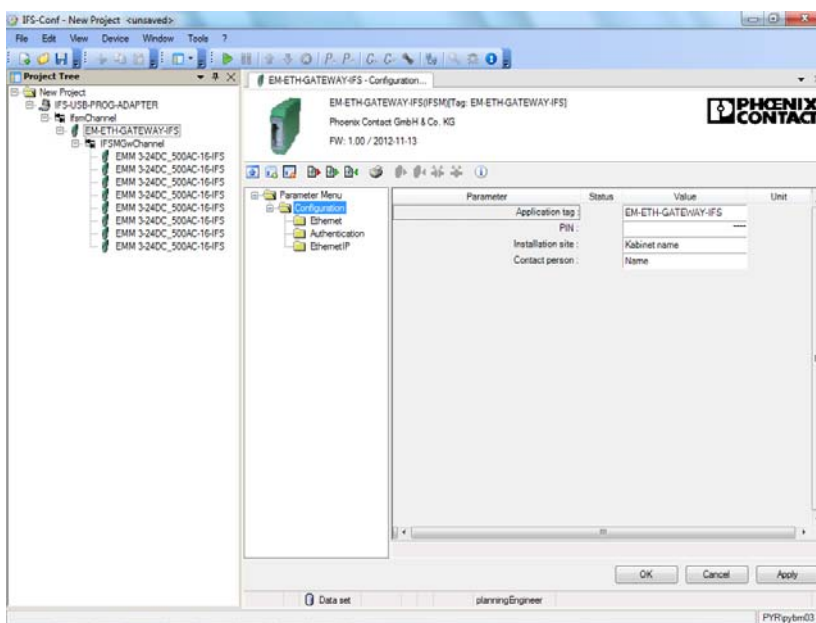

Figure 16-25 ETH gateway settings - configuration

Parameter	Selection	Interval	Program side
Application tag	- Max. 32 characters	-	EM-ETH-GATEWAY-IFS
PIN	- Min: 0 - Max: 9999	-	0000
Installation site	- Max. 32 characters	-	Kabinet name
Contact person	- Max. 32 characters	-	Name

**CONTACTRON motor management**

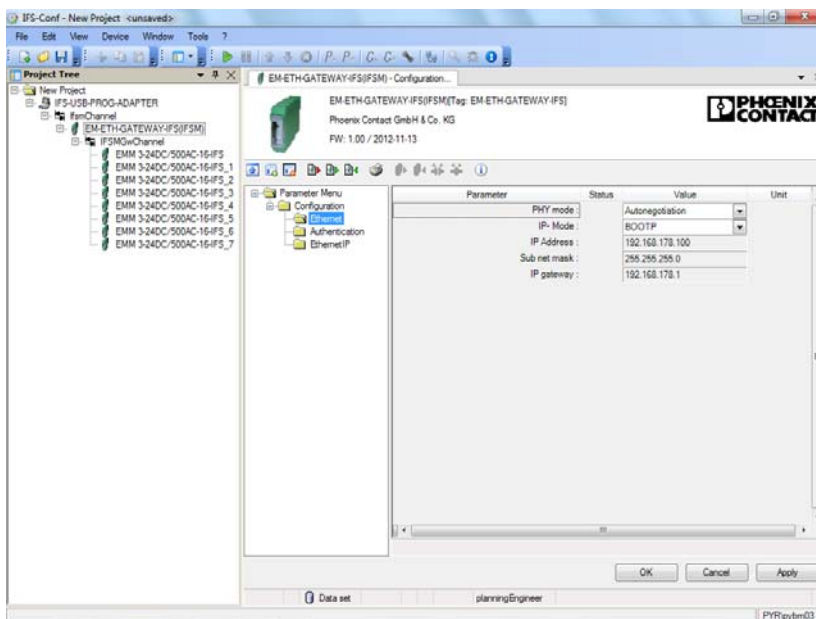

Figure 16-26 ETH gateway settings - Ethernet

Parameter	Selection	Interval	Program side
PHY mode	<ul style="list-style-type: none"> <li>- Autonegotiation</li> <li>- 10 Mbits, full duplex</li> <li>- 100 Mbits, half duplex</li> <li>- 100 Mbits, full duplex</li> </ul>	-	Autonegotiation
IP mode	<ul style="list-style-type: none"> <li>- BOOTP</li> <li>- Static IP address</li> <li>- DHCP</li> </ul>	-	BOOTP
IP address		-	192.168.178.100
Subnet mask		-	255.255.255.000
IP gateway		-	192.168.178.001

CONTACTRON-DTM-IFS device drivers

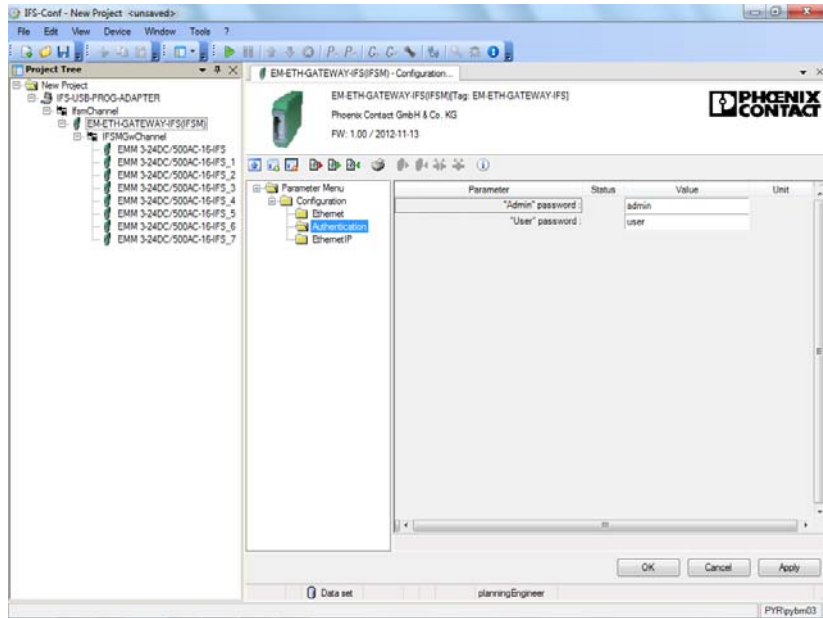

Figure 16-27 ETH gateway setting - authentication

Parameter	Selection	Interval	Program side
*Admin* password	– Max. 32 characters	–	admin
*User* password	– Max. 32 characters	–	user

**CONTACTRON motor management**

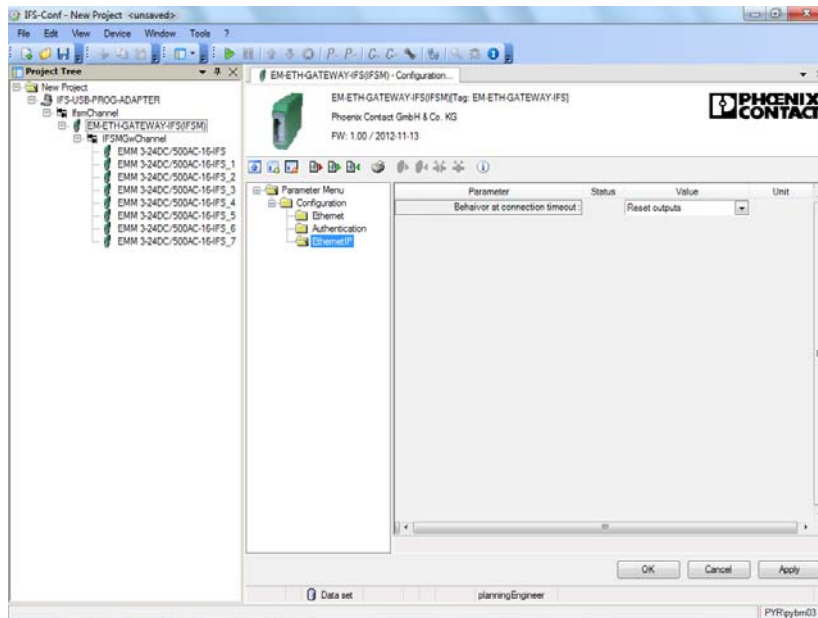

Figure 16-28 ETH gateway settings - Ethernet/IP

Parameter	Selection	Interval	Program side
Behavior at connection timeout	- Reset outputs	-	Reset outputs
	- Maintain last state		

### 16.7.3 RS-232 gateway EM-RS232-GATEWAY-IFS

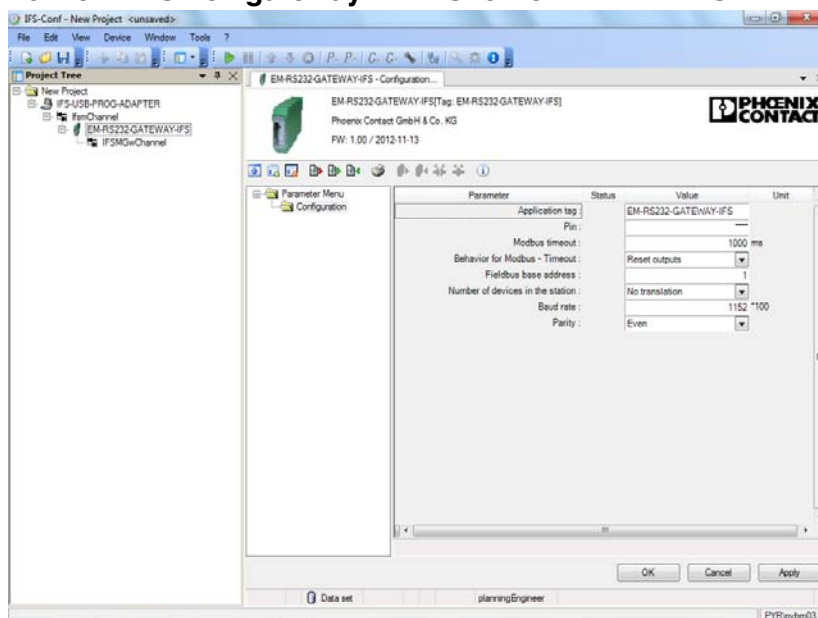

Figure 16-29 RS-232 gateway settings

Parameter	Selection	Interval	Program side
Application tag	– Max. 32 characters	–	EM-RS232-GATEWAY-IFS
Pin	– Min: 0 – Max: 9999	–	0000
Modbus timeout	– Min: 0 – Max: 60000	1	1000
Behavior for Modbus timeout	– Reset outputs – Maintain last state	–	Reset outputs
Fieldbus base address	– Min: 0 – Max: 255	1	1
Number of devices in the station	– No translation – 1 – 3 – 7 – 15 – 31	–	No translation
Baud rate	– Min: 96 – Max: 30000	1	1152
Parity	– None – Even – Odd	–	Even

## CONTACTRON motor management

## 16.7.4 RS-485 gateway EM-RS485-GATEWAY-IFS

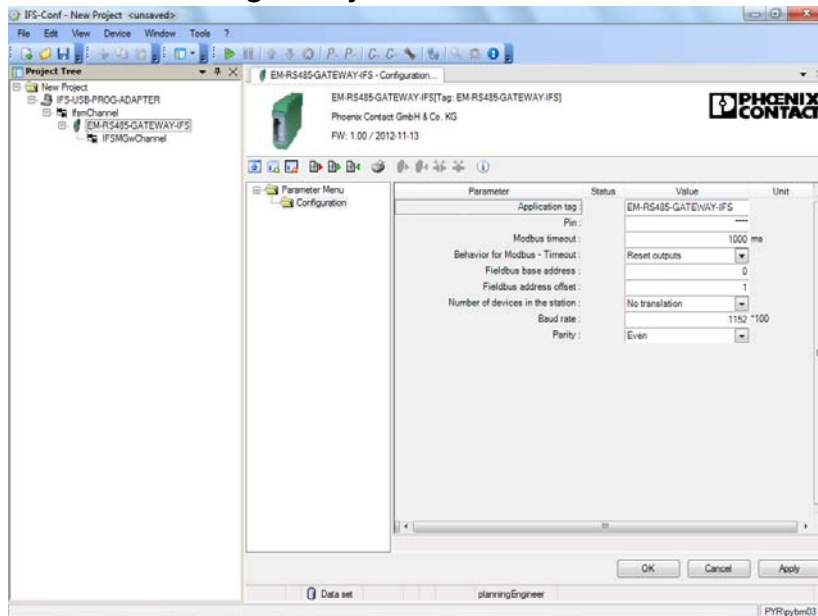

Figure 16-30 RS-485 gateway settings

Parameter	Selection	Interval	Program side
Application tag	– Max. 32 characters	–	EM-RS485-GATEWAY-IFS
Pin	– Min: 0 – Max: 9999	–	0000
Modbus timeout	– Min: 0 – Max: 60000	1	1000
Behavior for Modbus timeout	– Reset outputs – Maintain last state	–	Reset outputs
Fieldbus base address	– Min: 0 – Max: 255	1	0
Fieldbus address offset	– Min: 0 – Max: 255	1	1
Number of devices in the station	– No translation – 1 – 3 – 7 – 15 – 31	–	No translation
Baud rate	– Min: 96 – Max: 30000	1	1152
Parity	– None – Even – Odd	–	Even

### 16.7.5 PROFIBUS gateway EM-PB-GATEWAY-IFS

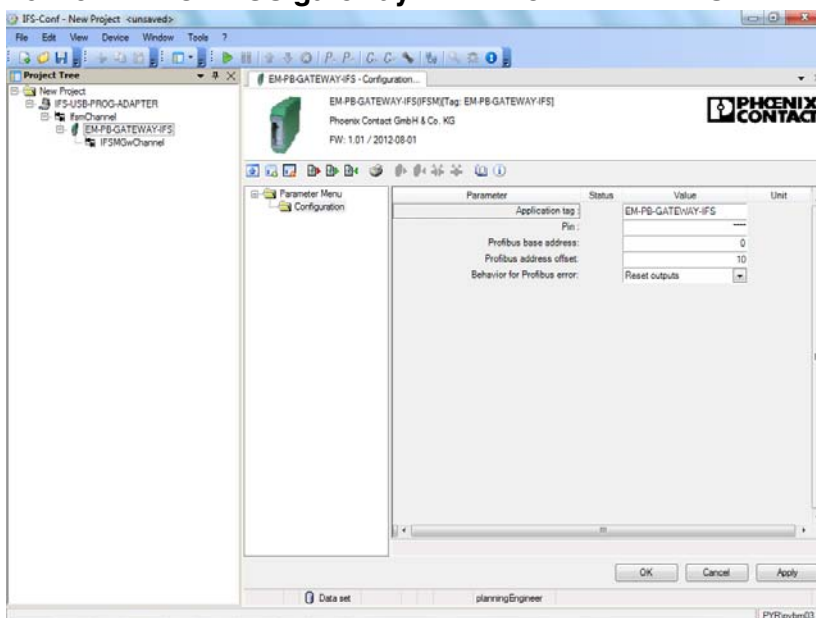

Figure 16-31 EM-PB-GATEWAY-IFS settings

Parameter	Selection	Interval	Program side
Application tag	– Max. 32 characters	–	EM-PB-GATEWAY-IFS
Pin	– Min: 0 – Max: 9999	–	0000
PROFIBUS base address	– Min: 0 – Max: 96	1	0
PROFIBUS address offset	– Min: 0 – Max: 31	1	10
Behavior for PROFIBUS error	– Reset outputs – Maintain last state	–	Reset outputs

CONTACTRON motor management

16.7.6 PROFINET gateway EM-PNET-GATEWAY-IFS

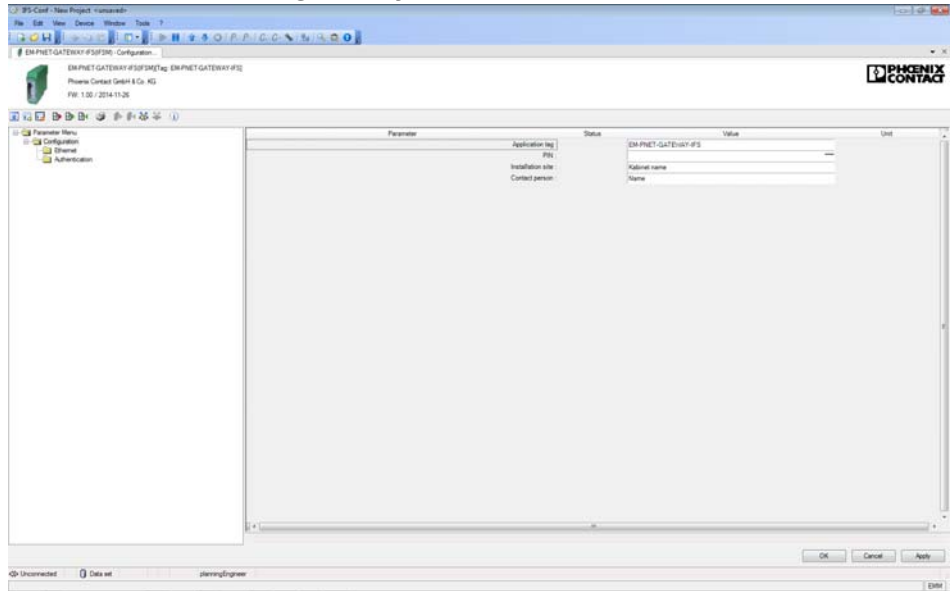

Figure 16-32 PROFINET gateway settings - configuration

Parameter	Selection	Interval	Program side
Application tag	- Max. 32 characters	-	EM-PNET-GATEWAY-IFS
PIN	- Min: 0 - Max: 9999	-	0000
Installation site	- Max. 32 characters	-	Kabinet name
Contact person	- Max. 32 characters	-	Name

CONTACTRON-DTM-IFS device drivers

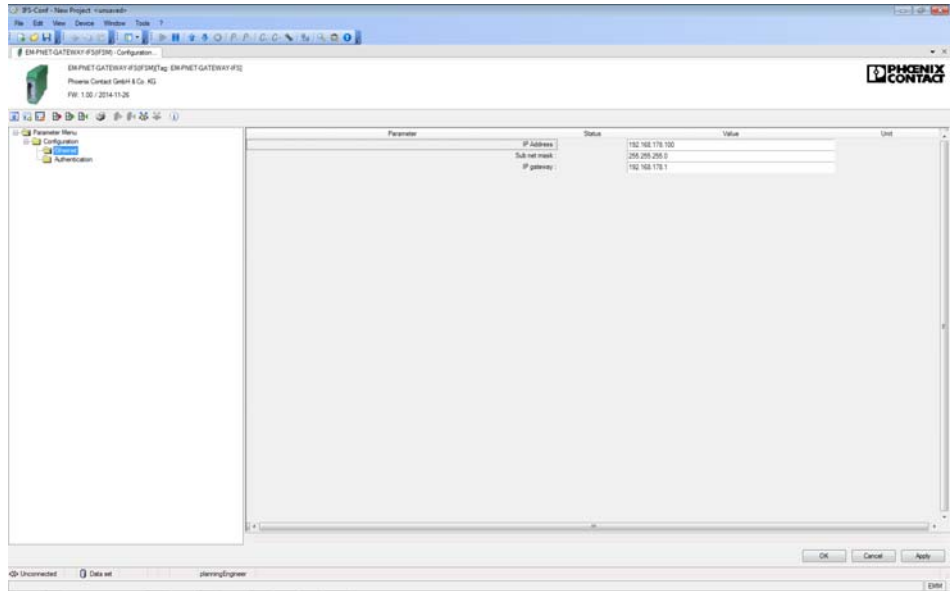

Figure 16-33 PROFINET gateway settings - Ethernet

Parameter	Selection	Interval	Program side
IP address	–	–	192.168.178.100
Subnet mask	–	–	255.255.255.0
IP gateway	–	–	192.168.178.1

## CONTACTRON motor management

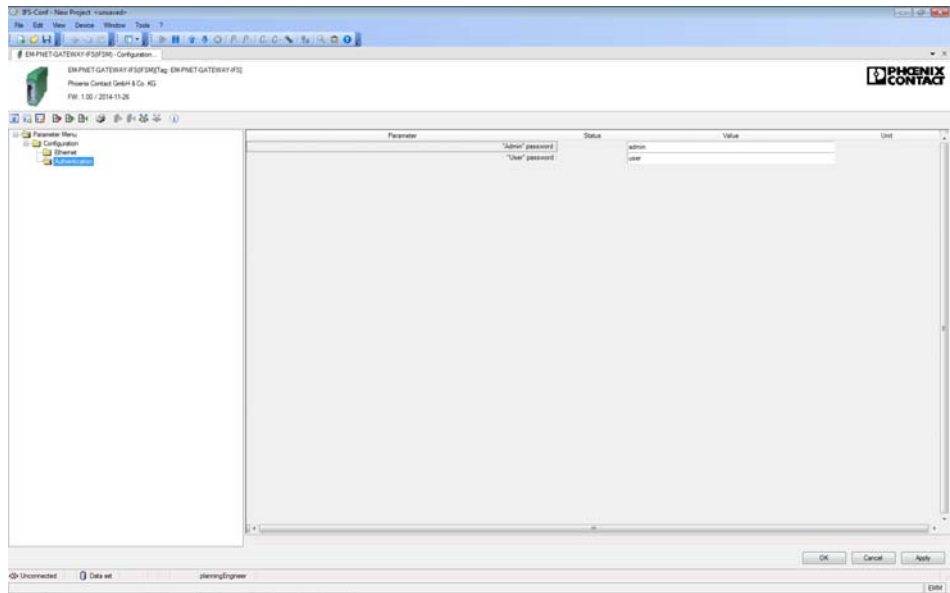

Figure 16-34 PROFINET gateway setting - authentication

Parameter	Selection	Interval	Program side
<b>*Admin* password</b>	– Max. 32 characters	–	admin
<b>*User* password</b>	– Max. 32 characters	–	user

### 16.7.7 Modbus gateway EM-MBUS-GATEWAY-IFS

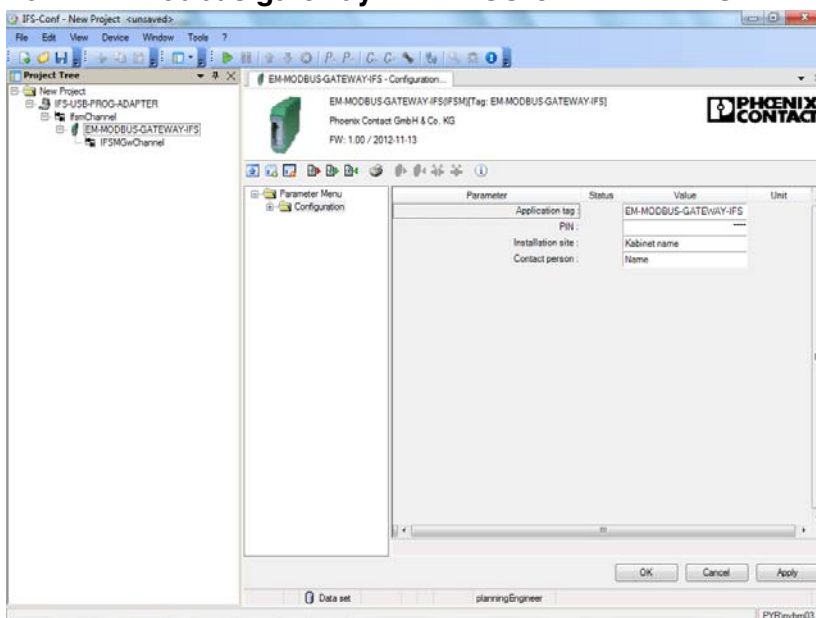

Figure 16-35 Modbus gateway settings - configuration

Parameter	Selection	Interval	Program side
Application tag	Max. 32 characters	–	EM-MBUS-GATEWAY-IFS
PIN	Min: 0 Max: 9999	–	0000
Installation site	Max. 32 characters	–	Kabinet name
Contact person	Max. 32 characters	–	Name

**CONTACTRON motor management**

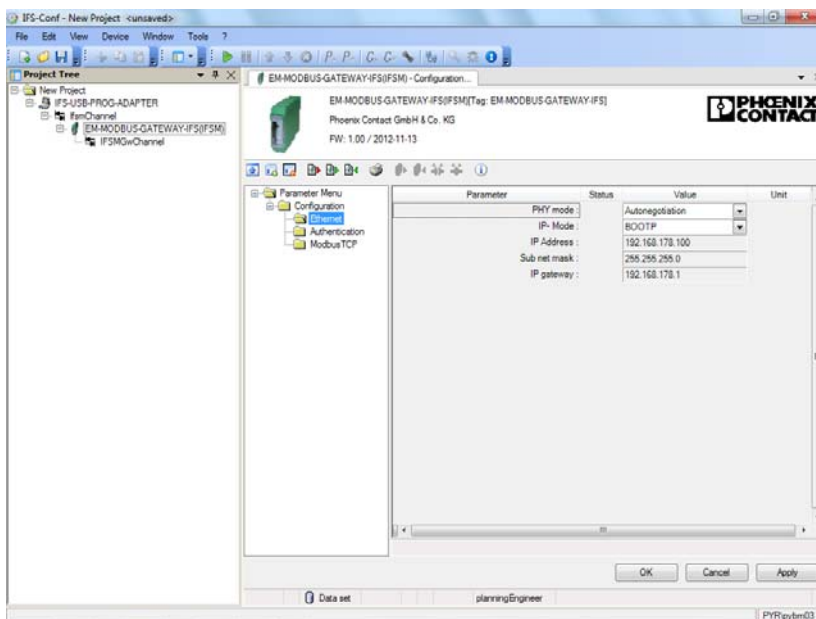

Figure 16-36 Modbus gateway settings - Ethernet

Parameter	Selection	Interval	Program side
PHY mode	<ul style="list-style-type: none"> <li>- Autonegotiation</li> <li>- 10 Mbits, full duplex</li> <li>- 100 Mbits, half duplex</li> <li>- 100 Mbits, full duplex</li> </ul>	-	Autonegotiation
IP mode	<ul style="list-style-type: none"> <li>- BOOTP</li> <li>- Static IP address</li> <li>- DHCP</li> <li>- DHCP or AutoIP</li> </ul>	-	BOOTP
IP address		-	192.168.178.100
Subnet mask		-	255.255.255.000
IP gateway		-	192.168.178.001

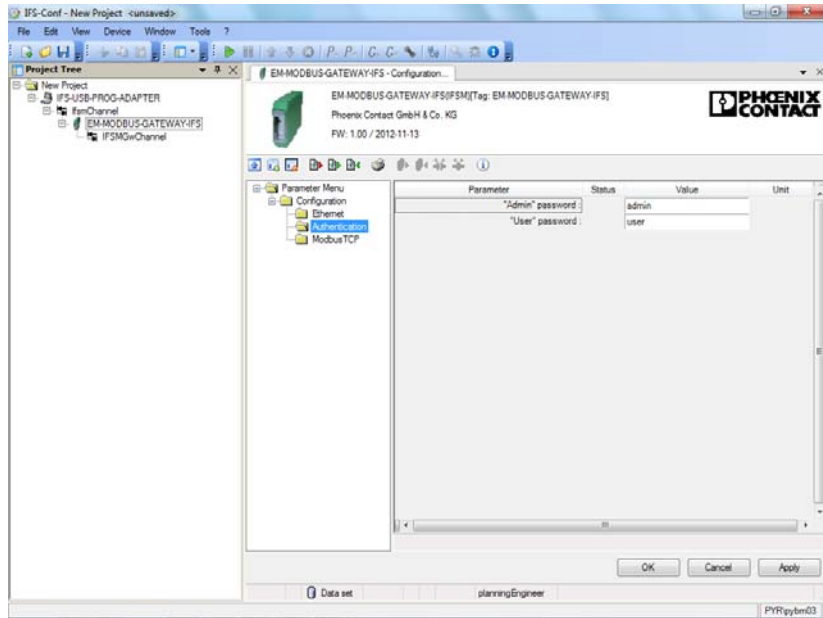

Figure 16-37 Modbus gateway settings - authentication

Parameter	Selection	Interval	Program side
*Admin* password	– Max. 32 characters	–	admin
*User* password	– Max. 32 characters	–	user

**CONTACTRON motor management**

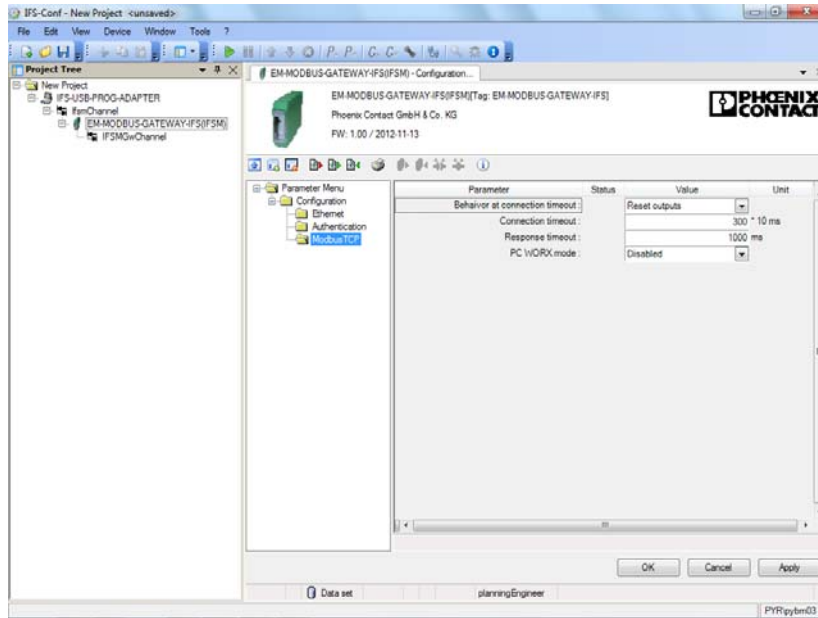

Figure 16-38 Modbus gateway settings - Modbus/TCP

Parameter	Selection	Interval	Program side
Behavior at connection timeout	<ul style="list-style-type: none"> <li>- Reset outputs</li> <li>- Maintain last state</li> </ul>	-	Reset outputs
Connection timeout	<ul style="list-style-type: none"> <li>- Min: 100</li> <li>- Max: 6000</li> </ul>	-	3000 ms
Response timeout	<ul style="list-style-type: none"> <li>- Min: 50</li> <li>- Max: 60000</li> </ul>	-	1000 ms
PC Worx mode	<ul style="list-style-type: none"> <li>- Disabled</li> <li>- Enabled</li> </ul>	-	Disabled

### 16.7.8 DeviceNet gateway EM-DNET-GATEWAY-IFS

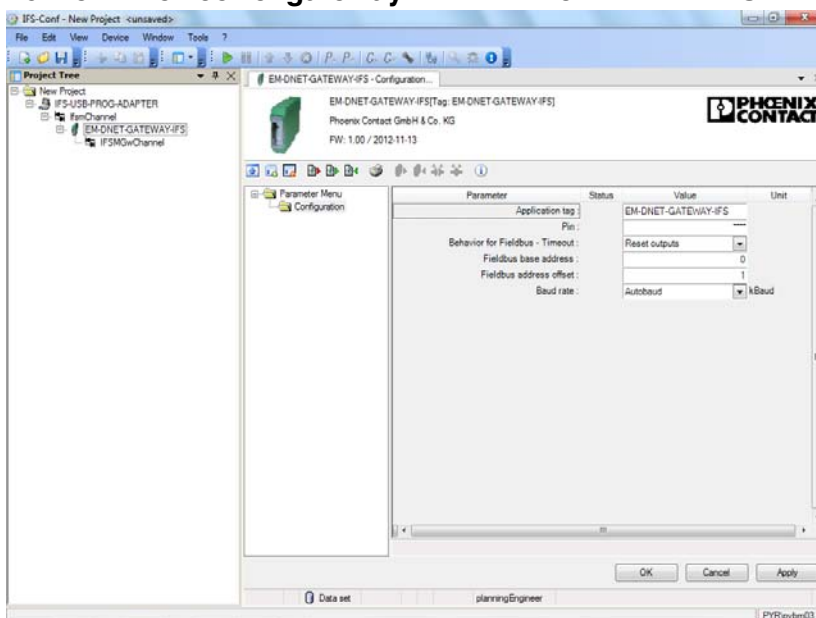

Figure 16-39 DeviceNet gateway settings

Parameter	Selection	Interval	Program side
Application tag	– Max. 32 characters	–	EM-DNET-GATEWAY-IFS
Pin	– Min: 0 – Max: 9999	–	0000
Behavior for fieldbus timeout	– Reset outputs – Maintain last state	–	Reset outputs
Fieldbus base address	– Min: 0 – Max: 255	1	0
Fieldbus address offset	– Min: 0 – Max: 255	1	10
Baud rate	– Autobaud – 125 – 250 – 500	–	Autobaud

## 16.8 Diagnostics dialog box

You can continually check the current states of the gateway via the diagnostics dialog box. In addition, IFS communication errors can be displayed for the individual devices.

1. To open the dialog box, right-click on the gateway and then on “Diagnosis”.

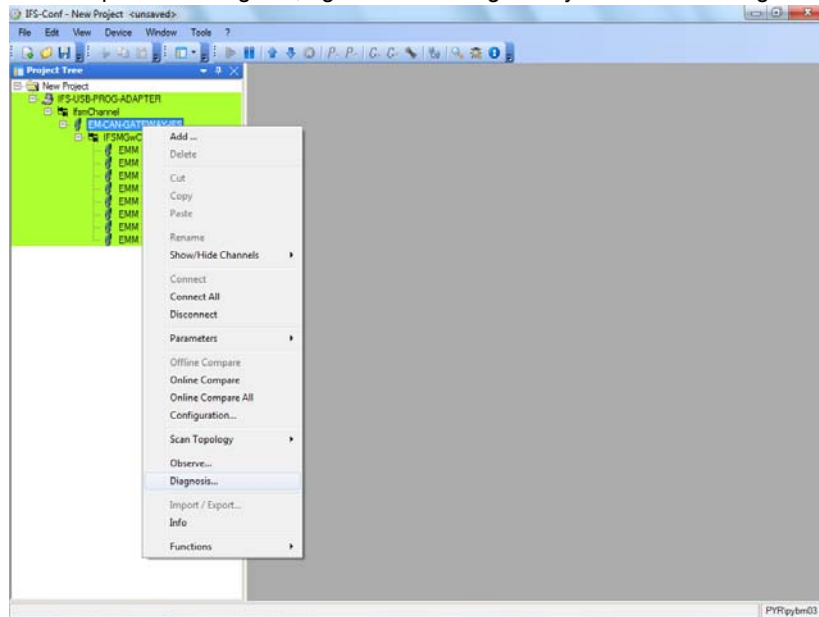

Figure 16-40 Opening the diagnostics dialog box

## 16.8.1 Overview

The overview dialog box displays all the operating data and status messages that provide initial information. This dialog box enables a quicker and more comprehensive overview of the gateway state.

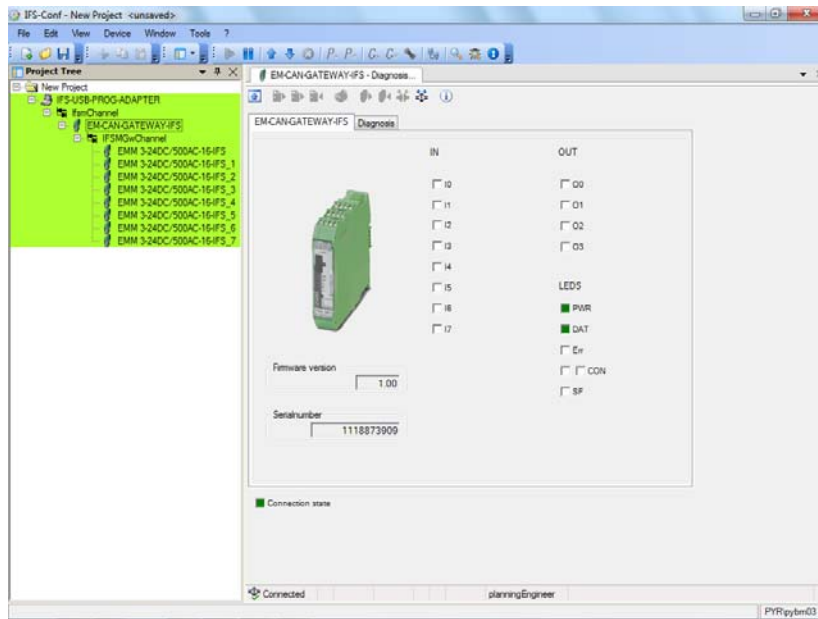

Figure 16-41 Tab 1 of the gateway diagnostics dialog box

## CONTACTRON motor management

### 16.8.2 Diagnostics

The "Diagnosis" dialog box displays all status messages of the devices connected to the IFS bus. This provides a quick overview of the IFS communication state.

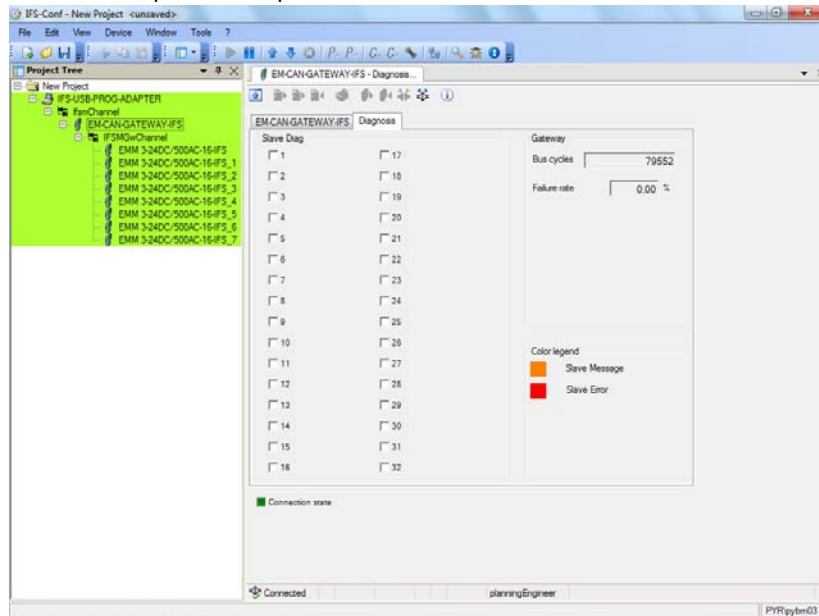

Figure 16-42 Tab 2 of the gateway diagnostics dialog box

## 16.9 Saving the project

You can save the project for further use of the project data, e.g., for comparable stations. To do so, go to “File, Save As...” and enter a name.

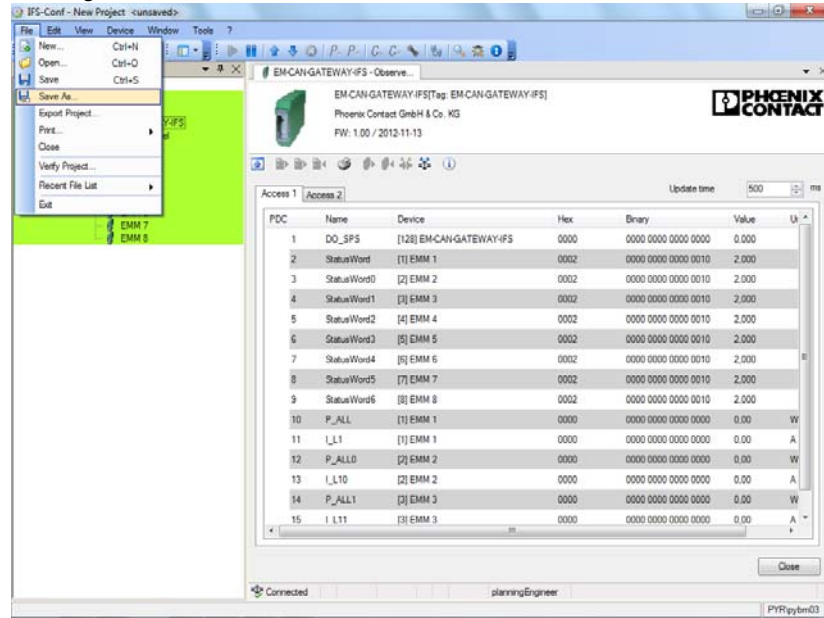

Figure 16-43 Saving the project

## CONTACTRON motor management

## 16.10 EMM 3- xx/500AC/xx-IFS module parameter menu

The operating behavior of the EMM 3- xx/500AC/xx-IFS module is adapted by means of the individual parameters that can be set. In the dialog boxes illustrated below, the parameters can be set according to the required application and transmitted to the EMM 3- xx/500AC/xx-IFS.



Parameters that are not edited are always preassigned the default settings on the program side.



Parameters that are modified in online mode must be saved separately on the service PC.

### 16.10.1 User interface

The parameter data of the EMM 3- xx/500AC/xx-IFS module can be accessed via a menu structure from the parameter user interface. The project data can either be loaded and modified in XML data format from the hard disk of the service PC or adapted directly in online mode.



An activated online connection to a EMM 3- xx/500AC/xx-IFS module is indicated by the green background in the project tree of "IFS-Conf".

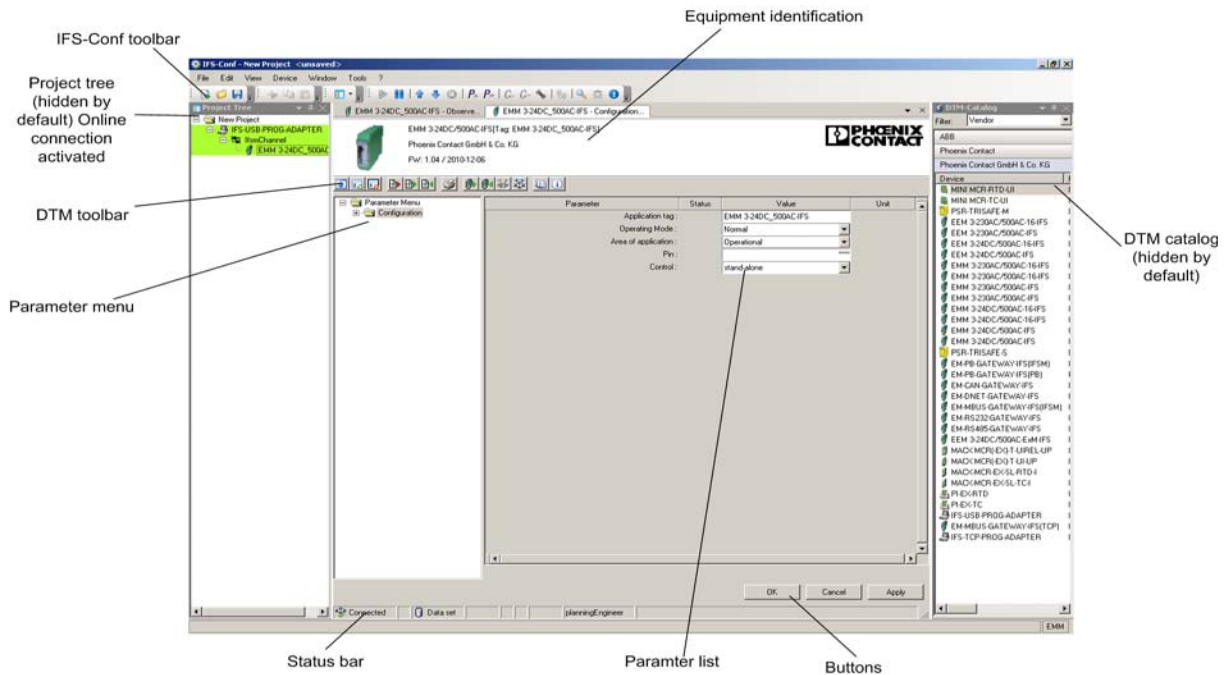



















Figure 16-44 Activated online connection to the EMM 3- xx/500AC/xx-IFS module

## 16.10.2 Buttons in the IFS-Conf toolbar













The toolbar consists of various buttons that enable quicker access to frequently used functions.

Icon	Meaning	Description
	Create new project	An empty project is created.
	Open project	A previously saved project is opened.
	Save project	The project that is currently open is saved.
	Establish connection to device	A connection is established to the device selected in the project tree.
	Disconnect connection to device	The connection to the device selected in the project tree is disconnected.
	Upload parameters from device	All parameters are loaded from the device into the project.
	Download parameters to device	All parameters are written to the device.
	Abort last action	The last action is aborted.
	Online parameters	The online parameters dialog box is opened.
	Offline parameters	The offline parameters dialog box is opened.
	Online comparison	No function
	Offline comparison	No function
	Configuration...	The configuration dialog box is opened.
	Scan topology...	A topology scan is started.
	Monitor...	The monitoring dialog box is opened.
	Diagnostics...	No function
	Info	No function

## CONTACTRON motor management

### 16.10.3 Buttons in the DTM toolbar

The toolbar consists of various buttons that enable quicker access to frequently used functions.

Icon	Meaning	Description
	Show/hide	Show/hide equipment identification for device identification
	Expand tree	Fully expand the parameter menu tree
	Collapse tree	Collapse the parameter menu tree
	Import default values	Load the default device configuration in the project
	Import	Load a saved device configuration in the project
	Export	Save the device configuration that is currently open to an XML file.  This function can be used to very easily parameterize several devices with the same settings. Please observe that the application tag must be different for every device on an IFS bus.
	Print	Open a clearly laid out version of the device configuration that is currently open for printing
	Read from device	Read device configuration from the connected device and transfer it to the project that is currently open
	Write to device	Write the device configuration that is currently open to the connected device
	Connect	Establish a connection to the connected device
	Disconnect	Disconnect the connection to the connected device
	User manual	Opens the user manual (PDF file)
	About this DTM	Opens an information dialog box with information about the installed DTM







In the event of technical queries regarding the parameterization of the EMM 3- xx/500AC/xx-IFS module, please have the details of the DTM used to hand ("About this DTM" button).







## 16.10.4 Status bar

The status bar displays short help texts for the menus and icons, and the connection status to the device.

### 16.10.4.1 Icons – General





Icon	Meaning	Description
	Modification valid	Modifications to the parameter settings are valid
	Modification invalid	Modifications to the parameter settings are invalid. The entered value is not within the valid value range.
	Device reset	The device is reset
	Direct mode	Connection established between service PC and device
	Update values	Values are updated

### 16.10.4.2 Icons – Diagnostics





Icon	Meaning	Description
	Device error	Device error, e.g., faulty thermistor protection
	Function test	A function test is being carried out
	Value limits	Limits of the value range exceeded
	Maintenance required	Determined values are not consistent
	Device OK	Output signals are within the valid value range
	Diagnostics deactivated	Diagnostics deactivated

## CONTACTRON motor management

### 16.10.4.3 Icons – Connection

Icon	Meaning	Description
	Establish connection	Establishing service PC/device connection
	Connection present	Connection present between service PC and device
	Disconnect connection	Disconnect connection between service PC and device
	Connection disconnected	Connection between service PC and device disconnected
	Connection error	Connection between service PC and device is faulty

### 16.10.4.4 Icons – Data source

Icon	Meaning	Description
	Data	Data is being loaded from the device/service PC. Modified values are only transmitted to the device/service PC.
	Data protected	Data from the device/service PC cannot be modified
	Data online	Data is being loaded online from the device/service PC.
	Access to the device disabled	Connection between service PC and device disconnected
	Data/device	The request contains values from various data sources, e.g., for use in online comparison (comparison of offline/online device data) Clear assignment between the devices and data is required.

## 16.11 EMM 3- xx/500AC/xx-IFS module DTM

### 16.11.1 Settings

Editing a project includes the settings for a selected device. Clicking on the “Configuration...” button in the IFS-Conf toolbar opens the “Configuration” dialog box.



If you have changed the settings of several devices connected to a gateway, all the settings can be transmitted simultaneously by selecting the “Download All Parameters” button (right-click on the gateway in the project tree).

### 16.11.1.1 Configuration

On the first dialog page for configuring the EMM 3- xx/500AC/xx-IFS module, the general data for the device is entered. This data can be used for clear identification, for example, using system and location designations.

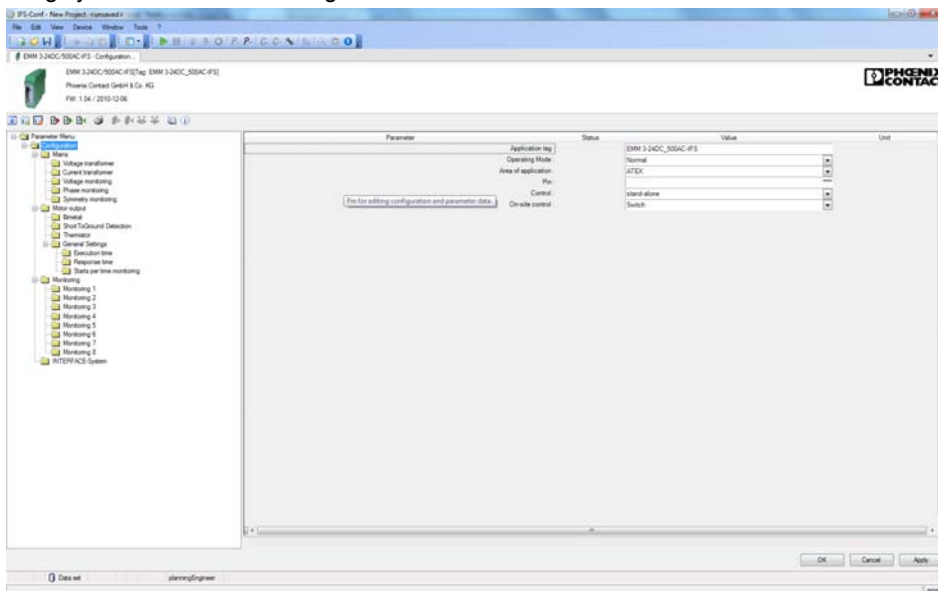

Figure 16-45 Overview of the general parameters

Parameter	Selection	Interval	Program side
Application tag	– Max. 32 characters	–	EMM...IFS
Operating mode	– Normal – Test mode (cold operation)	–	Normal
Area of application	– Operational – ATEX	–	ATEX
Pin	– Min: 0 – Max: 9999	–	0000
Control	– stand-alone – by IFS gateway	–	stand-alone
On-site control	– Switch – Button	–	Switch

## CONTACTRON motor management

---



### Test mode (cold operation)

Control functions are executed even with not load (e.g., motor) connected.

### ATEX area of application

Some ATEX-specific values are modified automatically by clicking "OK". Therefore check the settings that have already been made.

### Pin handling

In order to reset the PIN, write "0" once to the EMM...IFS.

### Control

If the EMM is controlled by an IFS gateway, "By IFS gateway" must be selected here. Input 3 on the EMM is then used for activating the "on-site control" (see "Program side default setting of inputs and outputs" on page 202).

**16.11.1.2 Voltage transducer**

If a 690 V voltage transducer (Order No. 2901667) is used before the EMM ... 500AC-IFS, it must be activated here so that the measured values are calculated correctly.



This function is only supported by the following EMM relays:

- EMM 3- 24DC/500AC-IFS (Order No. 2297497)
- EMM 3-230AC/500AC-IFS (Order No. 2297507)

This menu item is not available for device types with integrated current transformers.

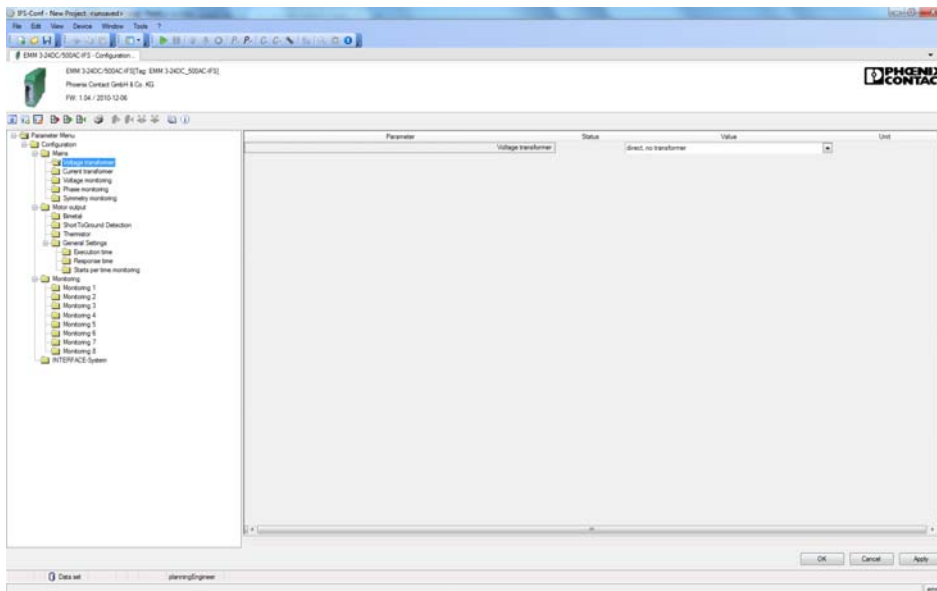

Figure 16-46 “Voltage transformer” configuration dialog box

The following parameter data can be set:

Parameter	Selection	Interval	Program side
Voltage transformer	- direct, no transformer	-	direct, no transformer
	- 690 V AC (Order No. 2901667)		

**CONTACTRON motor management**

**16.11.1.3 Current transformer**

Depending on the device used, a current transformer can be directly connected in order to record and transmit the measured currents. Depending on the transformation ratio, the primary current is transformed into a smaller electrically isolated secondary current.



This function is only supported by the following EMM relays:

- EMM 3- 24DC/500AC-IFS (Order No. 2297497)
- EMM 3-230AC/500AC-IFS (Order No. 2297507)

This menu item is not available for device types with integrated current transformers.

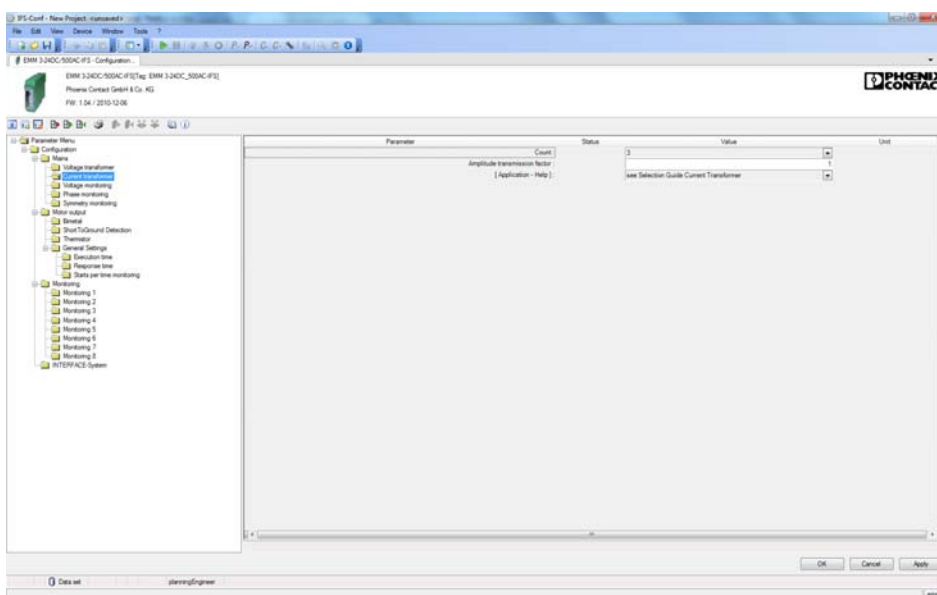

Figure 16-47 “Current transformer” configuration dialog box

The following parameter data can be set:

Parameter	Selection	Interval	Program side
<b>Count</b>	– 1 – 3	–	3
<b>Amplitude transmission factor</b>	– Min: 1 – Max: 1000	0.01	1
<b>[Application - Help]</b>	– see Selection Guide Current Transformer	–	see Selection Guide Current Transformer



“Current transformer selection guide” on page 145 contains an overview which you can use to find a suitable current transformer.

### 16.11.1.4 Voltage monitoring

The nominal voltage in low voltage networks is 230/400 V. Under normal operating conditions, the mains voltage at the transfer point can deviate from the nominal voltage by up to +/-10%. Momentary additional deviations also cannot be ruled out, neither can momentary mains failures. Nevertheless, to ensure safe operation, a mains regeneration time can be defined. To prevent possible damage to subsequent drives, the voltage monitoring parameters are set here.

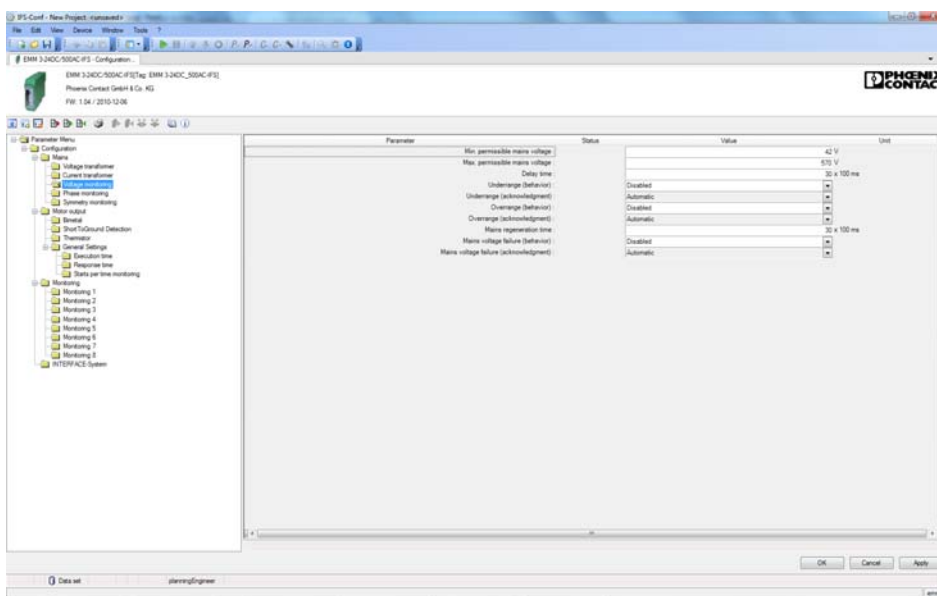

Figure 16-48 “Voltage monitoring” configuration dialog box

The following parameter data can be set:

Parameter	Selection	Interval	Program side
<b>Min. permissible mains voltage</b>	<ul style="list-style-type: none"> <li>- Min. 40</li> <li>- Max. 575 (EMM ... 16-IFS)</li> <li>- Max. 759 (EMM ... IFS)</li> </ul>	1	42
<b>Max. permissible mains voltage</b>	<ul style="list-style-type: none"> <li>- Min. 40</li> <li>- Max. 575 (EMM ... 16-IFS)</li> <li>- Max. 759 (EMM ... IFS)</li> </ul>	1	570
<b>Delay time</b>	<ul style="list-style-type: none"> <li>- Min. 0</li> <li>- Max. 60000</li> </ul>	1	30
<b>Underrange (behavior)</b>	<ul style="list-style-type: none"> <li>- Disabled</li> <li>- Disable drive</li> <li>- Generate message</li> </ul>	-	Disabled
<b>Underrange (acknowledgment)</b>	<ul style="list-style-type: none"> <li>- Automatic</li> <li>- Manual</li> </ul>	-	Automatic

**CONTACTRON motor management**

<b>Parameter</b>	<b>Selection</b>	<b>Interval</b>	<b>Program side</b>
<b>Overrange (behavior)</b>	<ul style="list-style-type: none"> <li>- Disabled</li> <li>- Disable drive</li> <li>- Generate message</li> </ul>	-	Disabled
<b>Overrange (acknowledgment)</b>	<ul style="list-style-type: none"> <li>- Automatic</li> <li>- Manual</li> </ul>	-	Automatic
<b>Mains regeneration time</b>	<ul style="list-style-type: none"> <li>- Min. 0</li> <li>- Max. 60000</li> </ul>	1	30
<b>Mains voltage failure (behavior)</b>	<ul style="list-style-type: none"> <li>- Disabled</li> <li>- Disable drive</li> <li>- Generate message</li> </ul>	-	Disabled
<b>Mains voltage failure (acknowledgment)</b>	<ul style="list-style-type: none"> <li>- Automatic</li> <li>- Manual</li> </ul>	-	Automatic

### 16.11.1.5 Phase monitoring

To ensure correct operation of the drive, all three phases in a three-phase network must be available. To detect the failure of a phase, the corresponding parameters can be set here.

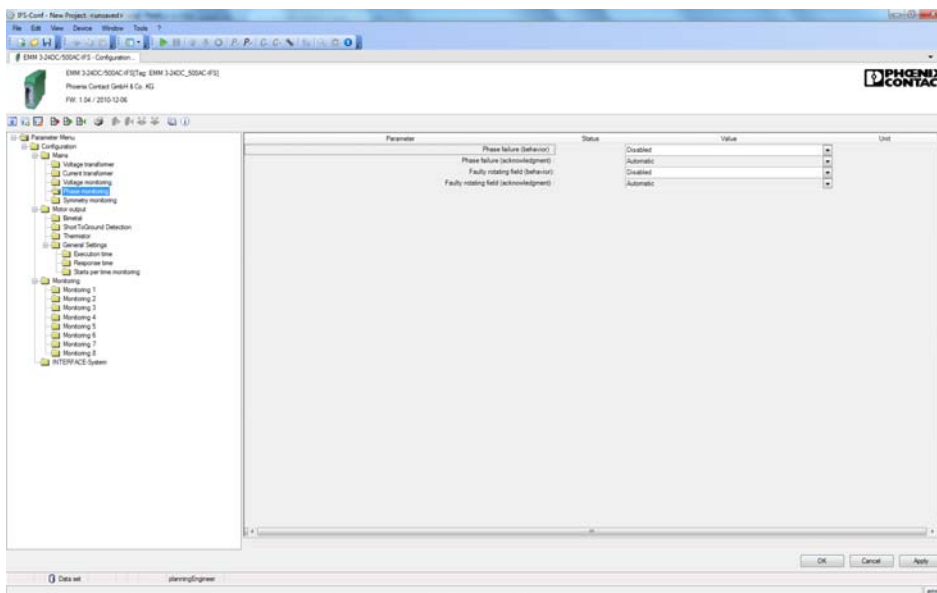

Figure 16-49 “Phase monitoring” configuration dialog box

The following parameter data can be set:

Parameter	Selection	Interval	Program side
<b>Phase failure (behavior)</b>	<ul style="list-style-type: none"> <li>- Disabled</li> <li>- Disable drive</li> <li>- Generate message</li> </ul>	-	Disabled
<b>Phase failure (acknowledgment)</b>	<ul style="list-style-type: none"> <li>- Automatic</li> <li>- Manual</li> </ul>	-	Automatic
<b>Faulty rotating field (behavior)</b>	<ul style="list-style-type: none"> <li>- Disabled</li> <li>- Disable drive</li> <li>- Generate message</li> </ul>	-	Disabled
<b>Faulty rotating field (acknowledgment)</b>	<ul style="list-style-type: none"> <li>- Automatic</li> <li>- Manual</li> </ul>	-	Automatic

**CONTACTRON motor management**

**16.11.1.6 Symmetry monitoring**

Deviations in voltage symmetry occur, e.g., due to uneven loads on the three conductors of the three-phase system when using powerful AC devices or due to the failure of one of the three voltages in the three-phase system. To prevent possible damage to subsequent drives, the symmetry monitoring parameters are set here.

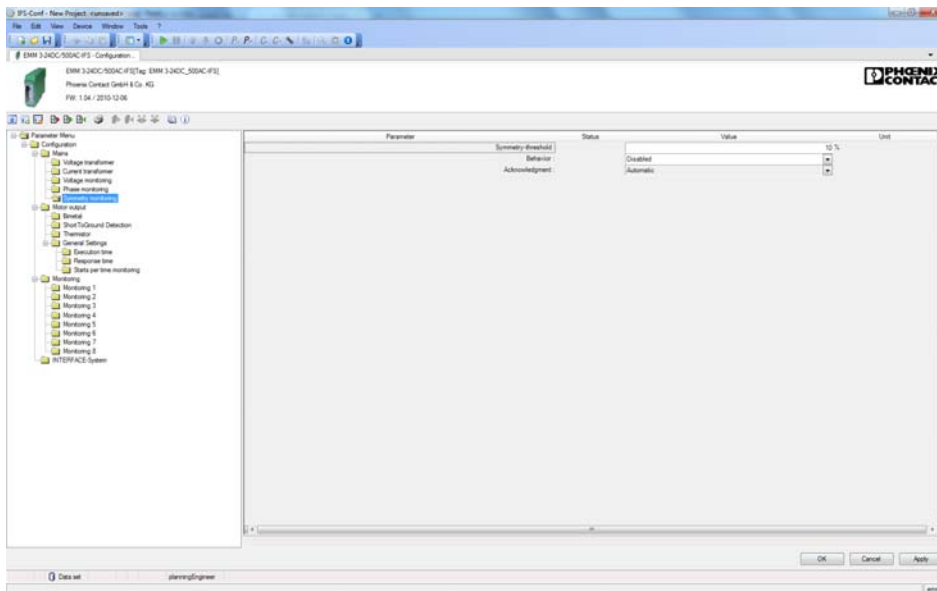

Figure 16-50 “Symmetry monitoring” configuration dialog box

The following parameter data can be set:

Parameter	Selection	Interval	Program side
<b>Symmetry threshold</b>	<ul style="list-style-type: none"> <li>- Min. 3</li> <li>- Max. 100</li> </ul>	1	10
<b>Behavior</b>	<ul style="list-style-type: none"> <li>- Disabled</li> <li>- Disable drive</li> <li>- Generate message</li> </ul>	-	Disabled
<b>Acknowledgment</b>	<ul style="list-style-type: none"> <li>- Automatic</li> <li>- Manual</li> </ul>	-	Automatic

16.11.1.7 Motor output

To control motor outputs, various switching output types are available by default. To prevent possible damage to the motor outputs or drives, set the required switching output type here.

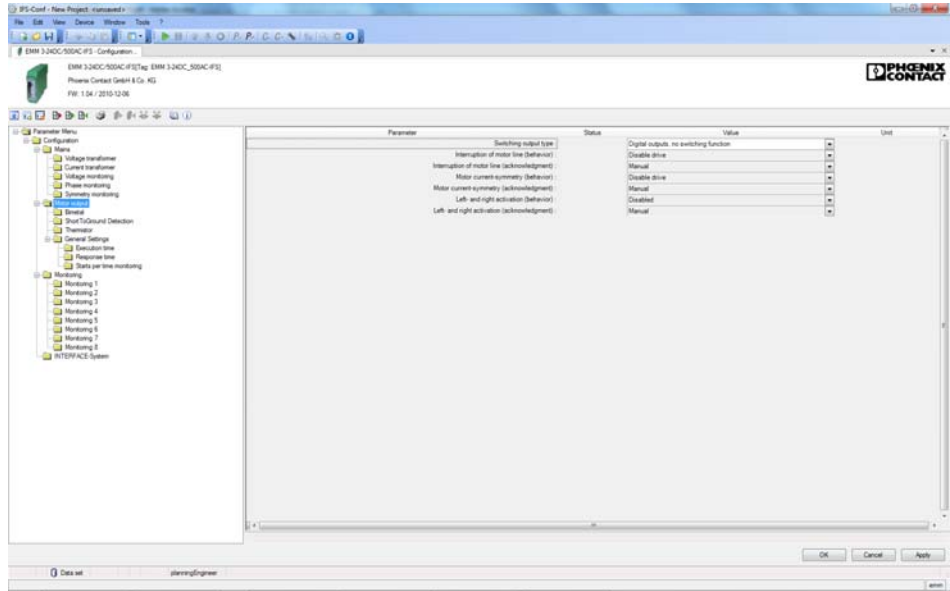

Figure 16-51 "Motor output" configuration dialog box

The following parameter data can be set:

Parameter	Selection	Interval	Program side
Switching output type	<ul style="list-style-type: none"> <li>- Digital outputs, no switching function</li> <li>- Direct starter</li> <li>- Reversing starter</li> <li>- Star/delta</li> <li>- Star/delta LR</li> </ul>	-	Digital outputs, no switching function
Interruption of motor line (behavior)	<ul style="list-style-type: none"> <li>- Disabled</li> <li>- Disable drive</li> <li>- Generate message</li> </ul>	-	Disable drive
Interruption of motor line (acknowledgment)	<ul style="list-style-type: none"> <li>- Manual</li> </ul>	-	Manual
Motor current symmetry (behavior)	<ul style="list-style-type: none"> <li>- Disabled</li> <li>- Disable drive</li> <li>- Generate message</li> </ul>	-	Disable drive
Motor current symmetry (acknowledgment)	<ul style="list-style-type: none"> <li>- Automatic</li> <li>- Manual</li> </ul>	-	Manual
Left- and right activation (behavior)	<ul style="list-style-type: none"> <li>- Disabled</li> <li>- Disable drive</li> <li>- Generate message</li> </ul>	-	Disabled

**CONTACTRON motor management**

Parameter	Selection	Interval	Program side
<b>Left- and right activation (acknowledgment)</b>	- Manual	-	Manual

**Program side default setting**

The inputs and outputs are assigned automatically depending on the selection of the switching output type, e.g., digital outputs. The signal and function assignment is fixed. See also "Output 1 ... 8 - IFS" on page 225.

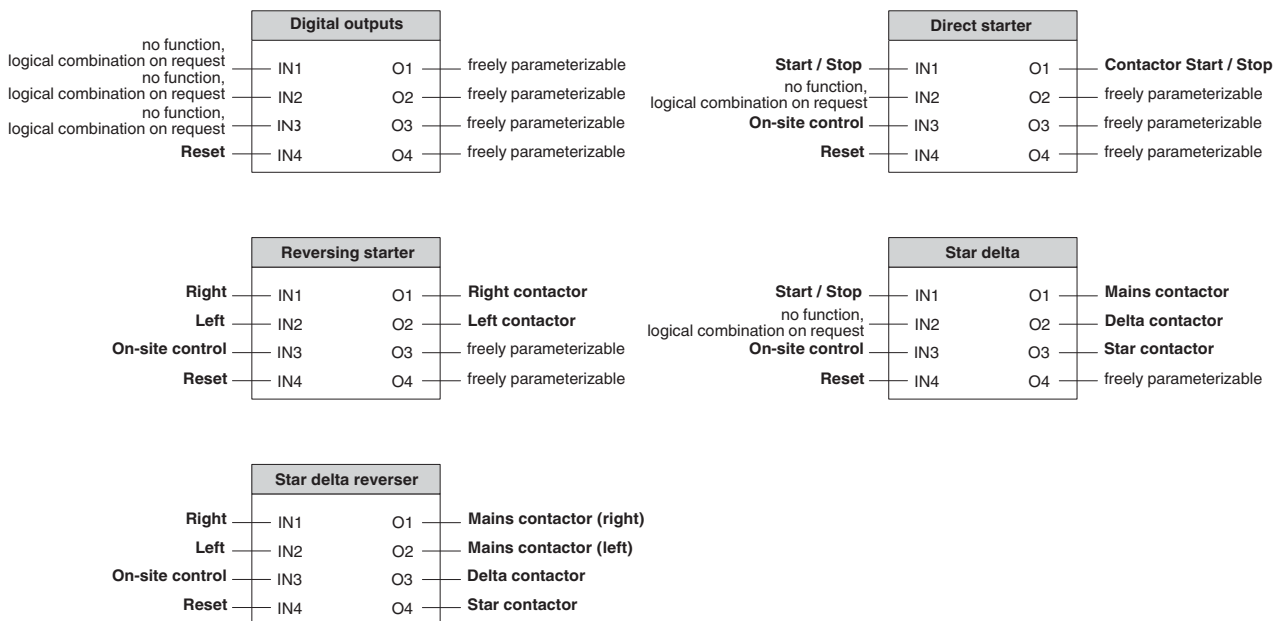

Figure 16-52 Program side default setting of inputs and outputs



If the EMM...IFS is connected to an EM-xx-GATEWAY-IFS, inputs 1 and 2 on the EMM are blocked and input 3 is used as the on-site control signal. When input 3 is controlled, the signal from the bus is interrupted and inputs 1 and 2 on the EMM are enabled so that on-site control can be implemented directly on the EMM. If the EMM...IFS is not connected to an EM-xxx-GATEWAY-IFS, input 3 has no function.

### 16.11.1.8 Bimetal

To protect the cables against thermal overload, the tripping behavior can be preset using specified tripping characteristics.



Blocking monitoring is activated with a motor current of 60 A or higher.

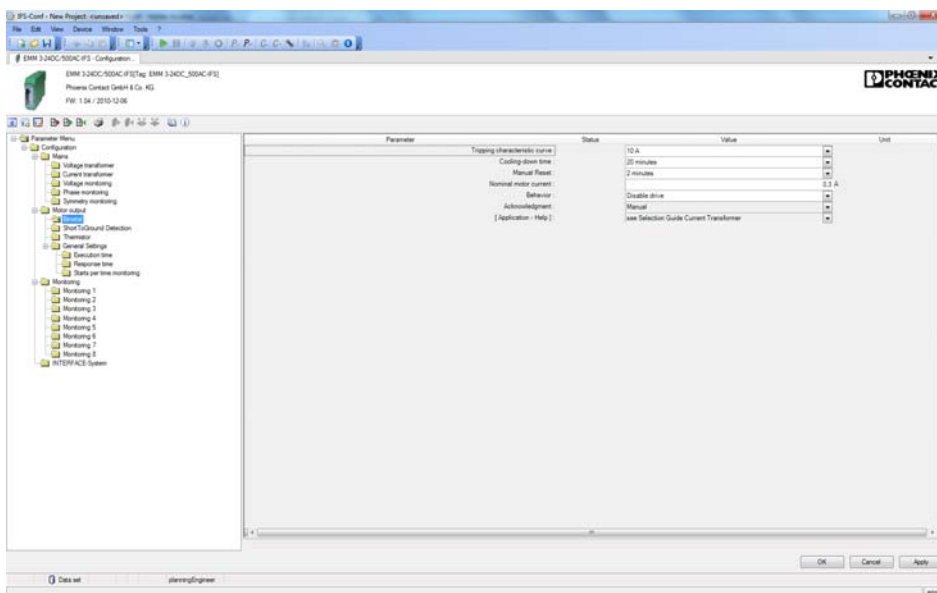

Figure 16-53 “Bimetal” configuration dialog box

The following parameter data can be set:

Parameter	Selection	Interval	Program side
<b>Tripping characteristic curve</b>	5, 10 A, 10, 15, 20, 25, 30, 35, 40	–	10 A
<b>Cooling-down time</b>	2 minutes, 5 minutes, 10 minutes, 20 minutes, 30 minutes, 40 minutes, 50 minutes, 1 hour, 1.5 hours, 2 hours	–	20 minutes
<b>Manual reset</b>	1 minute, 2 minutes, 5 minutes, 10 minutes, 20 minutes, 30 minutes, 40 minutes, 50 minutes, 1 hour, 1.5 hours, 2 hours	–	2 minutes
<b>Nominal motor current</b>	– Min. 1.0 A (for EMM...16-IFS) – Max: 16 A (for EMM...16-IFS) – Min. 0.3 A (for EMM...IFS) – Max: 4000 A (for EMM...IFS)	0.01 A	1.0 A (for EMM...16-IFS) 0.3 A (for EMM...IFS)
<b>Behavior</b>	– Disabled – Disable drive – Generate message	–	Disable drive
<b>Acknowledgment</b>	– Manual	–	Manual

**CONTACTRON motor management**

Parameter	Selection	Interval	Program side
[Application - Help]	- see Selection Guide Current Transformer	-	see Selection Guide Current Transformer



**NOTE: Thermal overload**

To prevent thermal overload of the drive, the parameterized value for the nominal motor current must correspond to the rating plate.

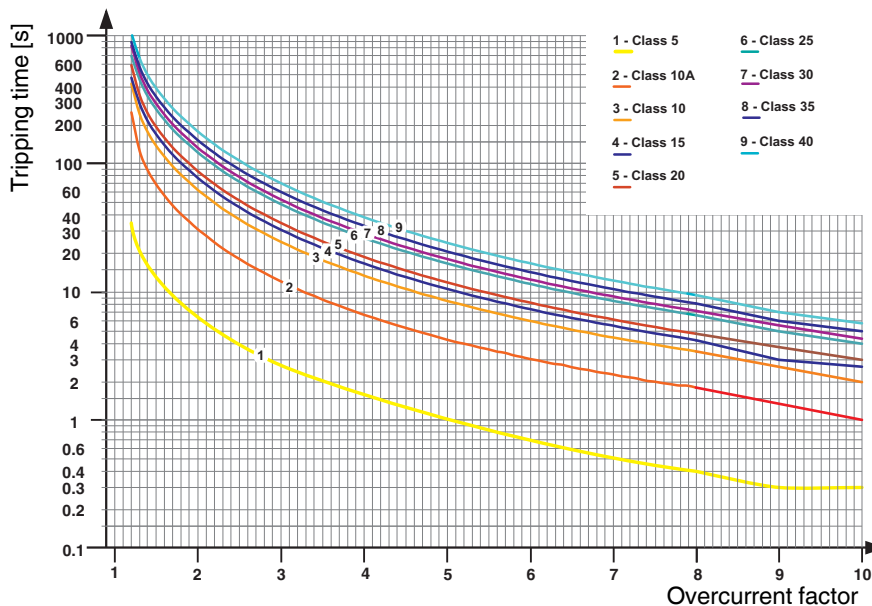

Figure 16-54 Tripping characteristic at 20°C (blocking protection)

The following tripping times apply according to the class curve:

Class	Tripping time
Class 5	0.4 s
Class 10A	1.8 s
Class 10	3.4 s
Class 15	4.1 s
Class 20	4.7 s
Class 25	6.4 s
Class 30	7.0 s
Class 35	7.8 s
Class 40	8.6 s

16.11.1.9 Ground fault detection

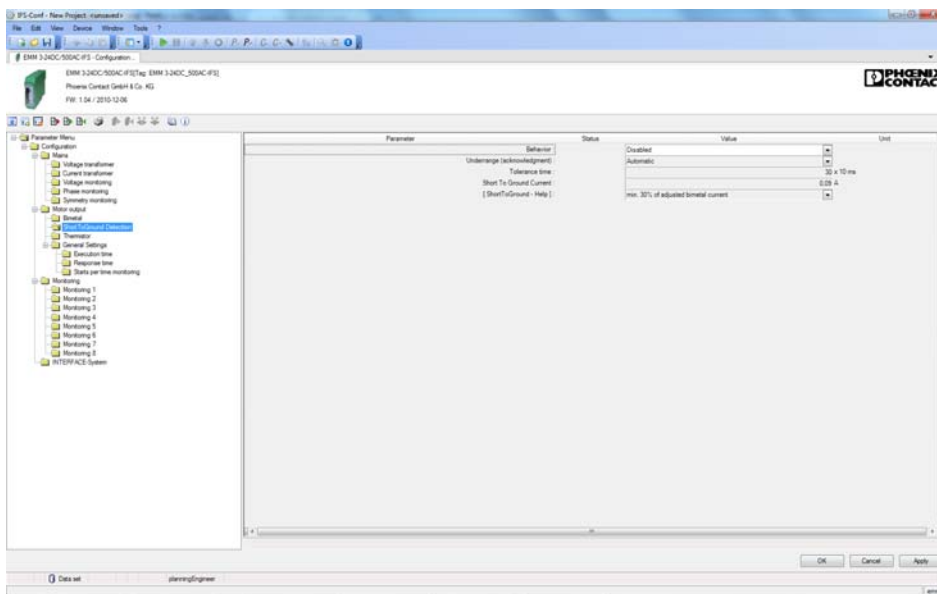

Figure 16-55 “ShortToGround Detection” configuration dialog box

The following parameter data can be set:

Parameter	Selection	Interval	Program side
<b>Behavior</b>	<ul style="list-style-type: none"> <li>- Disabled</li> <li>- Disable drive</li> <li>- Generate message</li> </ul>	-	Disabled
<b>Acknowledgment</b>	<ul style="list-style-type: none"> <li>- Automatic</li> <li>- Manual</li> </ul>	-	Automatic
<b>Tolerance time</b>	<ul style="list-style-type: none"> <li>- Min. 0</li> <li>- Max. 60000</li> </ul>	1	30
<b>Short To Ground Current</b>	- No setting possible, 30% of the adjusted bimetal current	-	-
<b>[ShortToGround - Help]</b>	- Calculated, min. 30% of the set bimetal current	0.01	-

**CONTACTRON motor management**

**16.11.1.10 Thermistor**

To protect the motor against thermal overload, if the motor winding is equipped with a thermistor, the appropriate behavior can be set here.

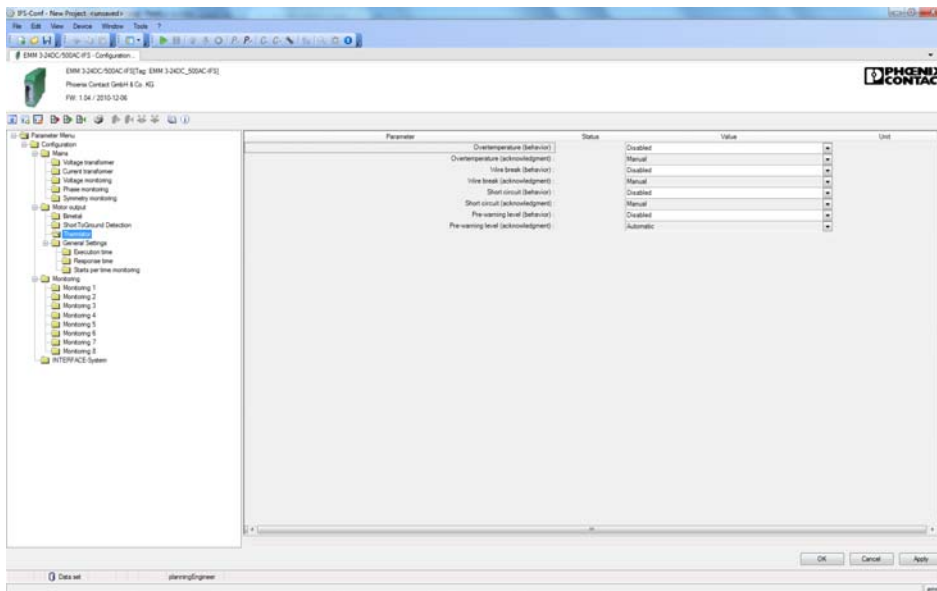

Figure 16-56 “Thermistor” configuration dialog box

The following parameter data can be set:

Parameter	Selection	Interval	Program side
<b>Overtemperature (behavior)</b>	<ul style="list-style-type: none"> <li>- Disabled</li> <li>- Disable drive</li> <li>- Generate message</li> </ul>	-	Disabled
<b>Overtemperature (acknowledgment)</b>	<ul style="list-style-type: none"> <li>- Automatic</li> <li>- Manual</li> </ul>	-	Manual
<b>Wire break (behavior)</b>	<ul style="list-style-type: none"> <li>- Disabled</li> <li>- Disable drive</li> <li>- Generate message</li> </ul>	-	Disabled
<b>Wire break (acknowledgment)</b>	<ul style="list-style-type: none"> <li>- Automatic</li> <li>- Manual</li> </ul>	-	Manual
<b>Short circuit (behavior)</b>	<ul style="list-style-type: none"> <li>- Disabled</li> <li>- Disable drive</li> <li>- Generate message</li> </ul>	-	Disabled
<b>Short circuit (acknowledgment)</b>	<ul style="list-style-type: none"> <li>- Automatic</li> <li>- Manual</li> </ul>	-	Manual
<b>Pre-warning level (behavior)</b>	<ul style="list-style-type: none"> <li>- Disabled</li> <li>- Disable drive</li> <li>- Generate message</li> </ul>	-	Disabled

**CONTACTRON-DTM-IFS device drivers**

---

<b>Parameter</b>	<b>Selection</b>	<b>Interval</b>	<b>Program side</b>
<b>Pre-warning level (acknowledgment)</b>	- Automatic - Manual	-	Automatic

**CONTACTRON motor management**

**16.11.1.11 Execution time**

If an activation/deactivation command is present, the switch-on/shutdown procedure must be completed within a parameterizable time (see “General settings” on page 219). The EMM ... IFS detects this by measuring the main circuit. The behavior in the event of an error is configured here.

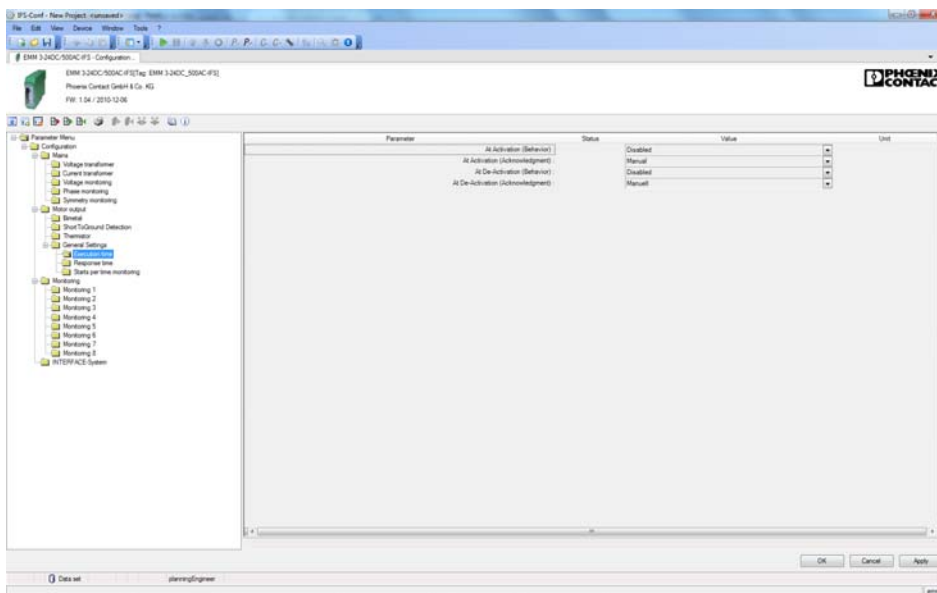

Figure 16-57 “Execution time” configuration dialog box

The following parameter data can be set:

Parameter	Selection	Interval	Program side
<b>At activation (behavior)</b>	<ul style="list-style-type: none"> <li>- Disabled</li> <li>- Disable drive</li> <li>- Generate message</li> </ul>	-	Disabled
<b>At activation (acknowledgment)</b>	<ul style="list-style-type: none"> <li>- Manual</li> </ul>	-	Manual
<b>At deactivation (behavior)</b>	<ul style="list-style-type: none"> <li>- Disabled</li> <li>- Disable drive</li> <li>- Generate message</li> </ul>	-	Disabled
<b>At deactivation (acknowledgment)</b>	<ul style="list-style-type: none"> <li>- Manual</li> </ul>	-	Manual

### 16.11.1.12 Response time

The EMM 3-xx/500AC-xx-IFS module monitors the confirmation of the control command. The confirmation behavior in the event of an error can be configured here.

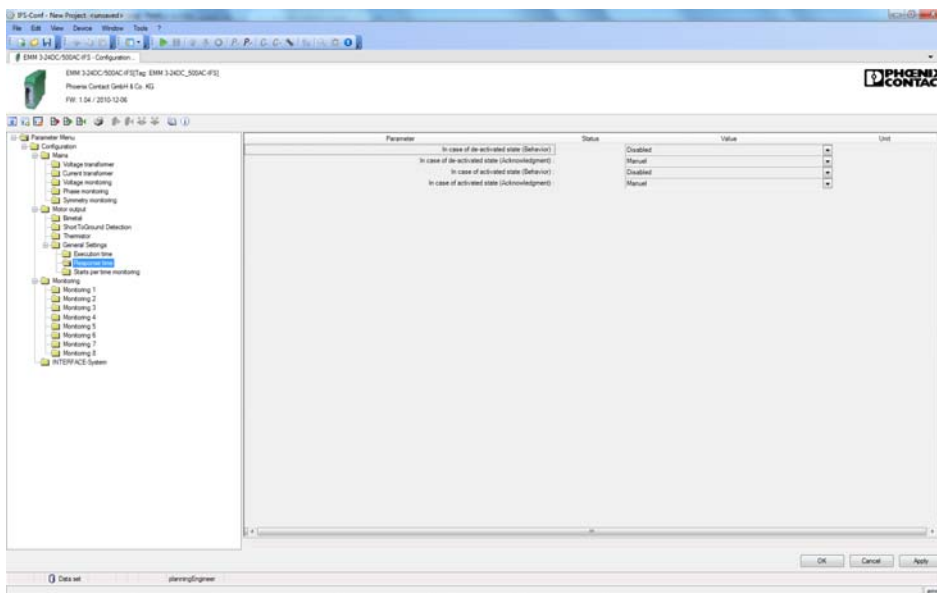

Figure 16-58 “Response time” configuration dialog box

The following parameter data can be set:

Parameter	Selection	Interval	Program side
In case of de-activated state (behavior)	<ul style="list-style-type: none"> <li>– Disabled</li> <li>– No restart</li> <li>– Generate message</li> </ul>	–	Disabled
In case of deactivated state (acknowledgment)	<ul style="list-style-type: none"> <li>– Manual</li> </ul>	–	Manual
In case of activated state (behavior)	<ul style="list-style-type: none"> <li>– Disabled</li> <li>– Disable drive</li> <li>– Generate message</li> </ul>	–	Disabled
In case of activated state (acknowledgment)	<ul style="list-style-type: none"> <li>– Manual</li> </ul>	–	Manual

**CONTACTRON motor management**

**16.11.1.13 Starts per time monitoring**

The EMM 3-xx/500AC-xx-IFS module monitors the number of starts within a defined time slot.

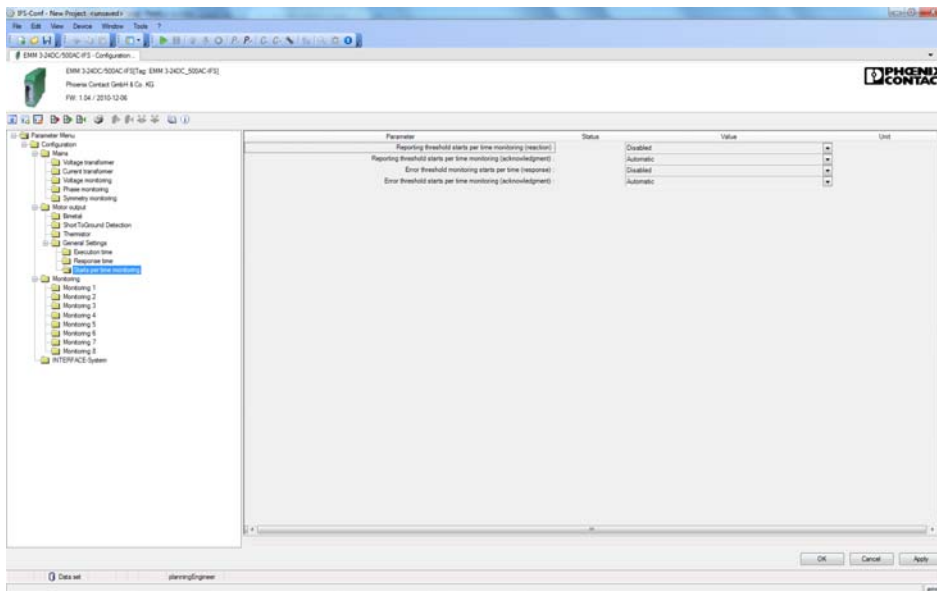

Figure 16-59 “Starts per time monitoring” configuration dialog box

The following parameter data can be set:

Parameter	Selection	Interval	Program side
Reporting threshold starts per time monitoring (reaction)	– Disabled – Generate message	–	Disabled
Reporting threshold starts per time monitoring (acknowledgment)	– Automatic – Manual	–	Automatic
Error threshold starts per time monitoring (reaction)	– Disabled – Generate message	–	Disabled
Error threshold starts per time monitoring (acknowledgment)	– Automatic – Manual	–	Automatic

16.11.1.14 Monitoring 1 ... 8

You can monitor up to eight measured values simultaneously and use them as switching or signaling thresholds depending on the configuration. This means that you can implement not only motor protection, but also protection for units or mechanical elements connected downstream, in particular.

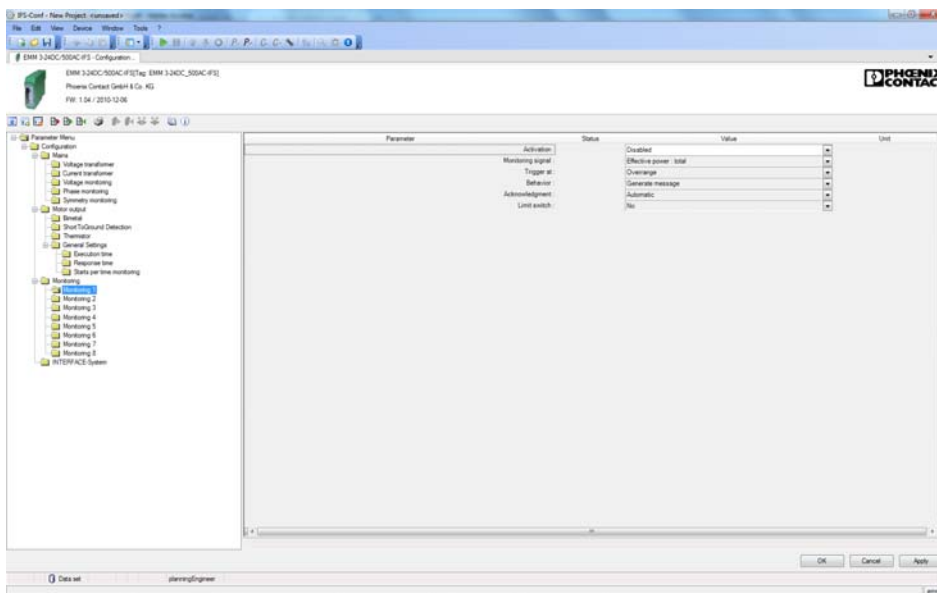

Figure 16-60 “Monitoring” configuration dialog box

The following parameter data can be set:

Parameter	Selection	Interval	Program side
<b>Activation</b>	<ul style="list-style-type: none"> <li>– Disabled</li> <li>– Always</li> <li>– During right and left rotation</li> <li>– During right rotation</li> <li>– During left rotation</li> <li>– On demand right rotation</li> <li>– On demand left rotation</li> </ul>	–	Disabled

## CONTACTRON motor management

Parameter	Selection	Interval	Program side
<b>Monitoring signal</b>	<ul style="list-style-type: none"> <li>- Effective power : total</li> <li>- Effective power : L1</li> <li>- Effective power : L2</li> <li>- Effective power : L3</li> <li>- Motor current : L1</li> <li>- Motor current : L2</li> <li>- Motor current : L3</li> <li>- Voltage : L1</li> <li>- Voltage : L2</li> <li>- Voltage : L3</li> <li>- Frequency</li> <li>- Apparent power</li> <li>- Apparent-power : L1</li> <li>- Apparent-power : L2</li> <li>- Apparent-power : L3</li> <li>- Non-active power</li> <li>- Non-active power : L1</li> <li>- Non-active power : L2</li> <li>- Non-active power : L3</li> <li>- Cos phi</li> <li>- Cos phi : L1</li> <li>- Cos phi : L2</li> <li>- Cos phi : L3</li> <li>- Energy meter</li> <li>- Energy meter reset</li> <li>- Elapsed-hour meter left rotation</li> <li>- Elapsed-hour meter left rotation reset</li> <li>- Elapsed-hour meter right rotation</li> <li>- Elapsed-hour meter right rotation reset</li> <li>- Elapsed-hour meter last interval</li> <li>- Operating cycle counters left rotation</li> <li>- Operating cycle counters left rotation reset</li> <li>- Operating cycle counter right rotation</li> <li>- Operating cycle counter right rotation reset</li> <li>- Standstill time</li> <li>- Standstill time last interval</li> </ul>		Effective power : total
<b>Trigger at</b>	<ul style="list-style-type: none"> <li>- Overrange</li> <li>- Underrange</li> </ul>		Overrange
<b>Behavior</b>	<ul style="list-style-type: none"> <li>- Disable drive</li> <li>- Generate message</li> </ul>		Generate message
<b>Acknowledgment</b>	<ul style="list-style-type: none"> <li>- Automatic</li> <li>- Manual</li> </ul>		Automatic

**CONTACTRON-DTM-IFS device drivers**

---

<b>Parameter</b>	<b>Selection</b>	<b>Interval</b>	<b>Program side</b>
<b>Limit switch</b>	- No - Left - Right		No

**CONTACTRON motor management**

**16.11.1.15 INTERFACE system**

The device's behavior in the event of an error in the INTERFACE system can be set here.

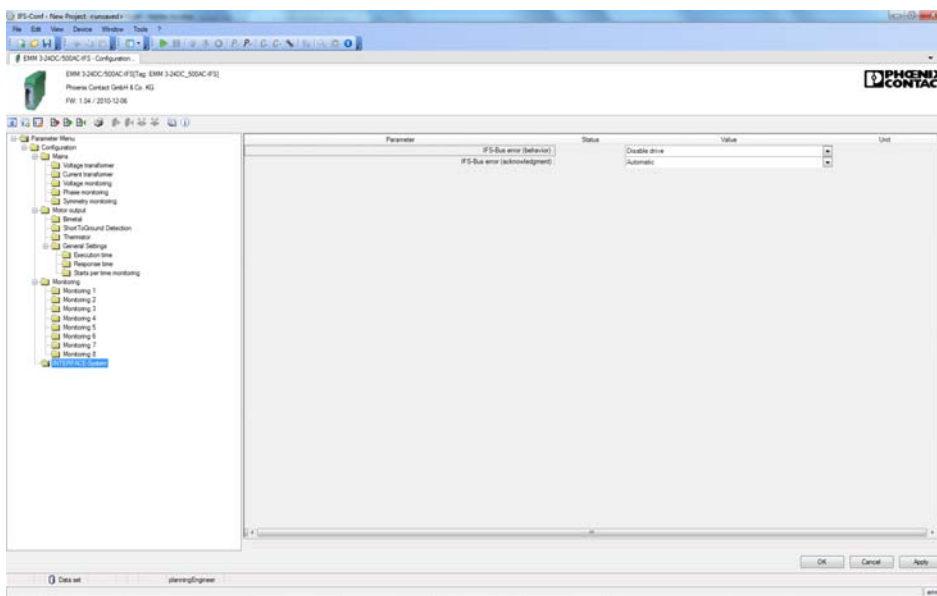

Figure 16-61 “INTERFACE-System” configuration dialog box

The following parameter data can be set:

Parameter	Selection	Interval	Program side
<b>IFS-Bus error (behavior)</b>	- Disabled	-	Disable drive
	- Disable drive		
	- Generate message		
<b>IFS-Bus error (acknowledgment)</b>	- Automatic	-	Automatic
	- Manual		

## 16.11.2 Online/offline parameters



Before opening the online or offline parameter dialog box, the changes made in the “Configuration” dialog box should be applied.

Clicking on the “Online parameters” or “Offline parameters” button in the IFS-Conf toolbar opens the parameter dialog box.

Online and offline parameters differ as follows:

- Online parameters  
The values are read directly from the device and are also written directly to the device by clicking “Apply” or “OK”.
- Offline parameters  
The values are written to the project that is open on the PC. When started for the first time, the default parameter data is displayed.

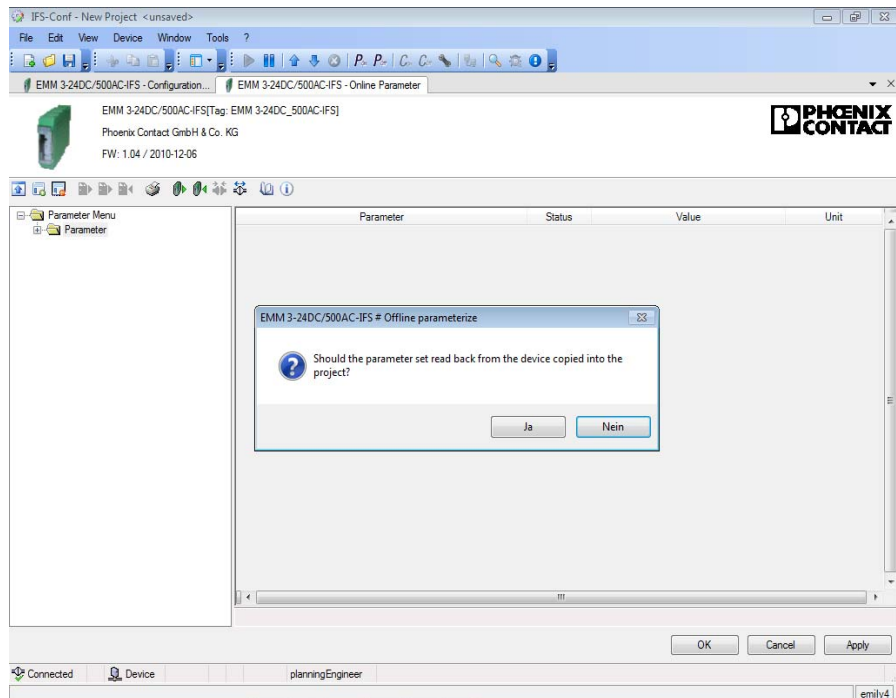

Figure 16-62 Message when switching to the “Online Parameter” dialog box



If you wish to proceed in the “Online Parameter” dialog box, you must first write the changes made to the device by clicking on “Write to device”.

If you wish to proceed in the “Offline Parameter” dialog box, you must first click “Apply” or “OK” in the “Configuration” dialog box.

**CONTACTRON motor management**

**16.11.2.1 Min. switchover delay time**

To prevent damage to the motor output, e.g., due to a short circuit of the main circuits, a minimum switch-over delay time must be observed when changing direction. The duration of the switch-over delay time ensures that the two main circuits are not activated simultaneously.



So that the fields are activated, the switching output type must be set to “Reversing starter” or “Star/delta LR” in the “Motor output” configuration window.

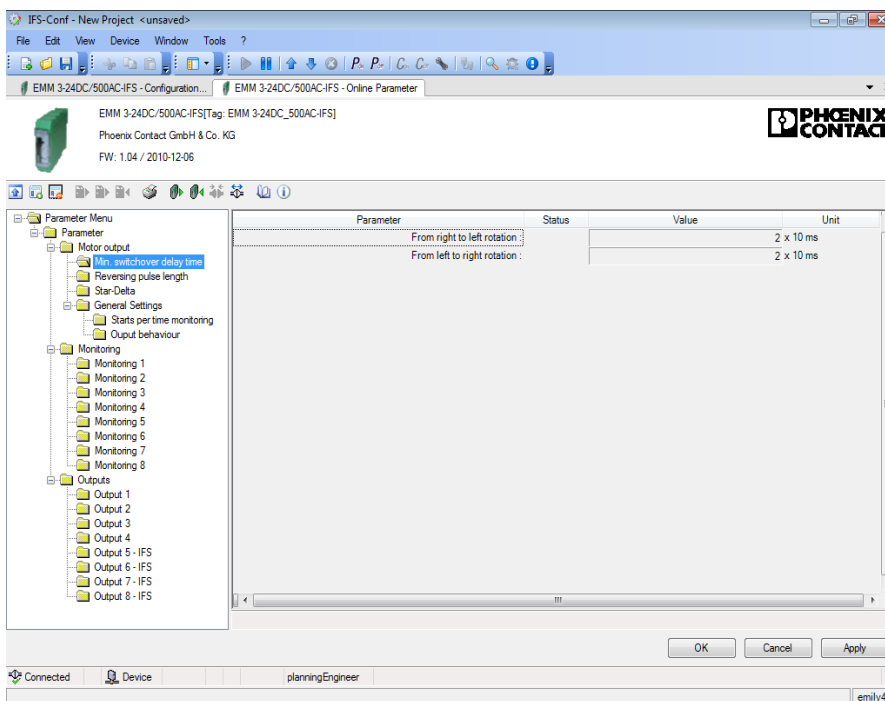

Figure 16-63 “Min. switchover delay time” parameter dialog box

The following parameter data can be set:

Parameter	Selection	Interval	Program side
From right to left rotation	– Min: 1	1	2
	– Max: 60000		
From left to right rotation	– Min: 1	1	2
	– Max: 60000		

### 16.11.2.2 Reversing pulse length

To prevent mechanical damage to the drive, e.g., due to the sudden stopping of moving masses, a reversing pulse length must be provided when changing direction.



So that the fields are activated, the switching output type must be set to “Reversing starter” or “Star/delta LR” in the “Motor output” configuration window.

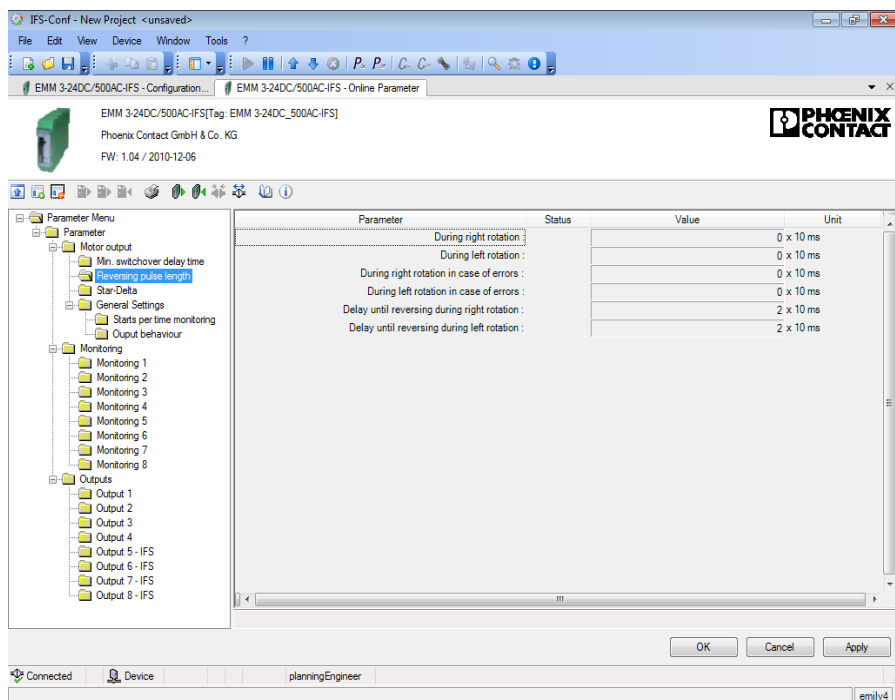

Figure 16-64 “Reversing pulse length” parameter dialog box

The following parameter data can be set:

Parameter	Selection	Interval	Program side
<b>During right rotation</b>	– Min: 0 – Max: 60000	1	0
<b>During left rotation</b>	– Min: 0 – Max: 60000	1	0
<b>During right rotation in case of errors</b>	– Min: 0 – Max: 60000	1	0
<b>During left rotation in case of errors</b>	– Min: 0 – Max: 60000	1	0
<b>Delay until reversing during right rotation</b>	– Min: 0 – Max: 60000	1	2
<b>Delay until reversing during left rotation</b>	– Min: 0 – Max: 60000	1	2

**CONTACTRON motor management**

**16.11.2.3 Star/delta**

A star/delta circuit is used to enable larger three-phase motors with short-circuit rotors (from approximately 5.5 kW) to start up. This prevents fuses from tripping and any voltage dips caused by the high starting current during direct switch on.

- Switch-over from star circuit to delta circuit must not be possible until the motor has started up. If switch-over is initiated too soon, a strong surge current occurs and switch-over is consequently not achieved.
- By reducing the torque to one third, the star/delta switch-over can only take place under undemanding startup conditions, e.g., when starting no-load machine tools.



So that the fields are activated, the switching output type must be set to “Star/delta” or “Star/delta LR” in the “Motor output” configuration window.

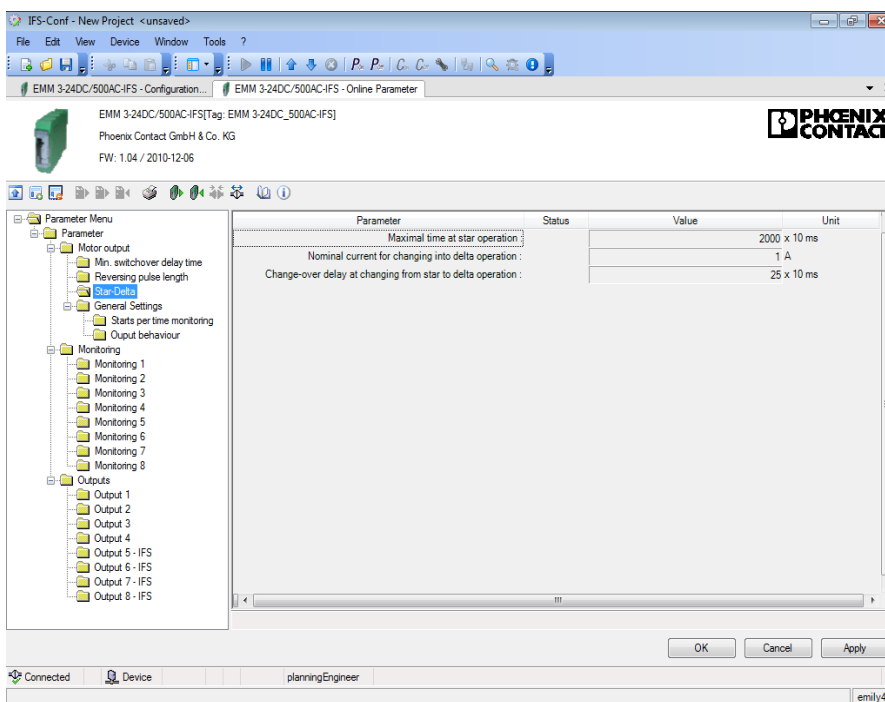

Figure 16-65 “Star-Delta” parameter dialog box

The following parameter data can be set:

Parameter	Selection	Interval	Program side
<b>Maximal time at star operation</b>	– Min: 0 – Max: 60000	1	2000
<b>Nominal current for changing into delta operation</b>	– Min: 0 – Max: 160000	0.01	1
<b>Change-over delay at changing from star to delta operation</b>	– Min: 25 – Max: 60000	1	25

### 16.11.2.4 General settings

The times for the behavior of the execution time and response time set under Section “Execution time” on page 208 and Section “Response time” on page 209 can be configured here.

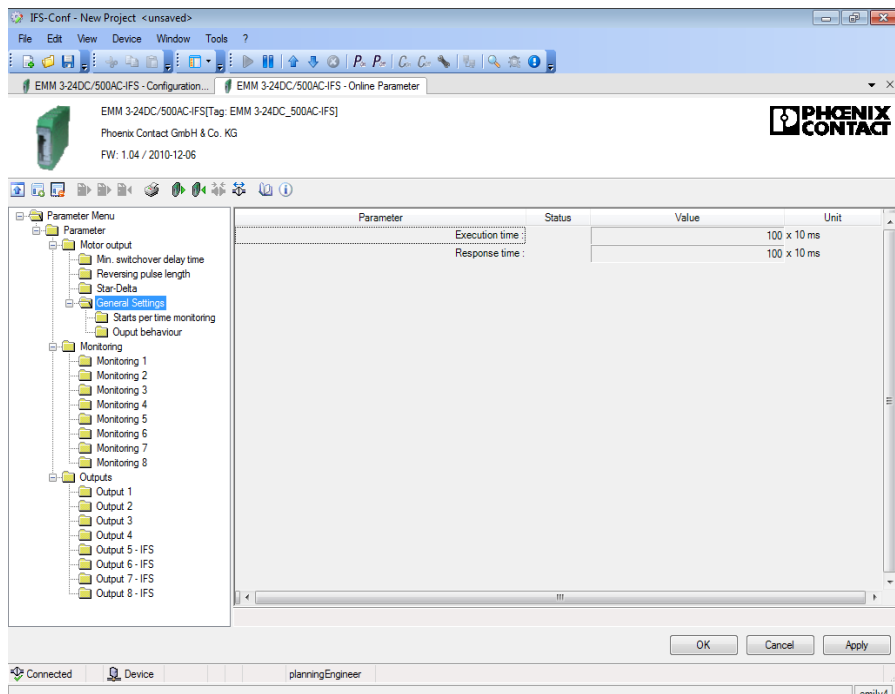

Figure 16-66 “General Settings” parameter dialog box

The following parameter data can be set:

Parameter	Selection	Interval	Program side
<b>Execution time</b>	– Min: 0	1	100
	– Max: 60000		
<b>Response time</b>	– Min: 0	1	100
	– Max: 60000		

**CONTACTRON motor management**

**16.11.2.5 Starts per time monitoring**

The time interval and the number of starts for the behavior set under “Starts per time monitoring” on page 210 can be configured here.

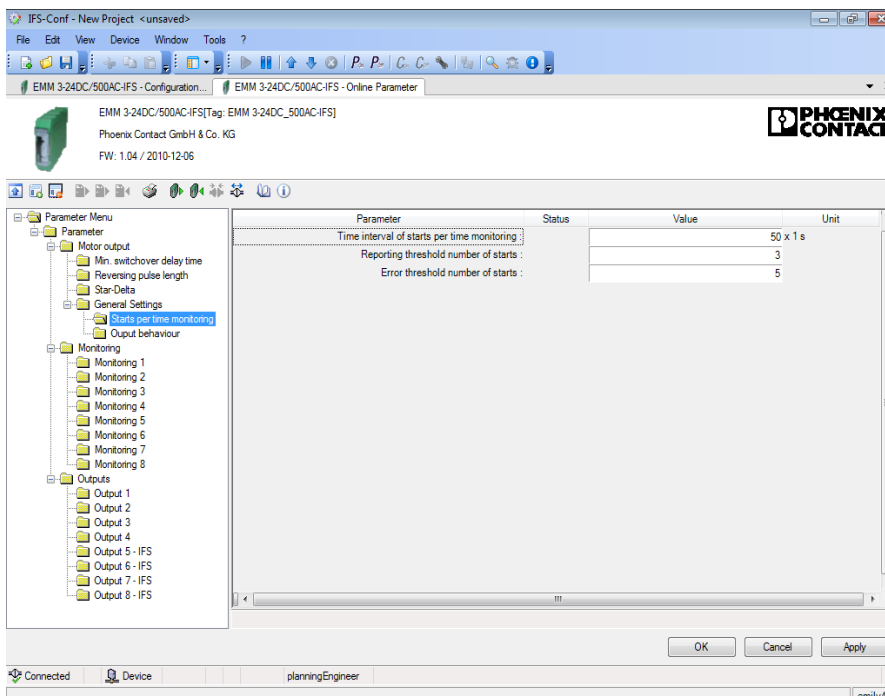

Figure 16-67 “Starts per time monitoring” parameter dialog box

The following parameter data can be set:

Parameter	Selection	Interval	Program side
<b>Time interval of starts per time monitoring</b>	– Min: 10 – Max: 60000	1	300
<b>Reporting threshold number of starts</b>	– Min: 10 – Max: 60000	1	10
<b>Error threshold number of starts</b>	– Min: 10 – Max: 60000	1	15

### 16.11.2.6 Output behavior

The delayed output function in the event of a pending input signal can be defined here.

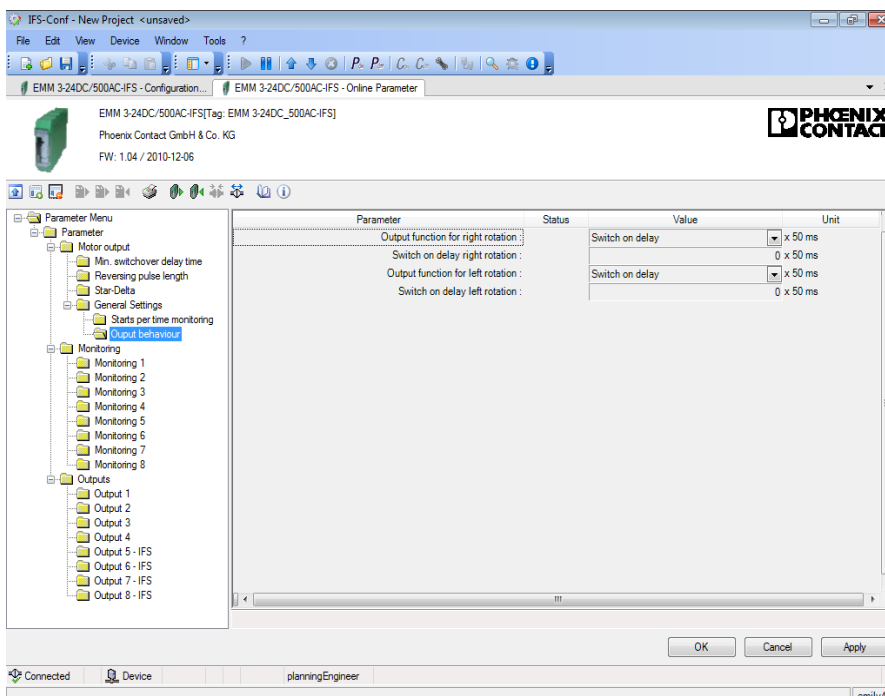

Figure 16-68 “Output behavior” parameter dialog box

The following parameter data can be set:

Parameter	Selection	Interval	Program side
<b>Output function for right rotation</b>	– Switch on delay	–	Switch on delay
<b>Switch on delay right rotation</b>	– Min: 0 – Max: 1000	1	0
<b>Output function for left rotation</b>	– Switch on delay	–	Switch on delay
<b>Switch on delay left rotation</b>	– Min: 0 – Max: 1000	1	0

**CONTACTRON motor management**

**16.11.2.7 Monitoring 1 ... 8**

The switching or signaling thresholds for the monitoring functions set under Section “Monitoring 1 ... 8” on page 211 can be configured here.

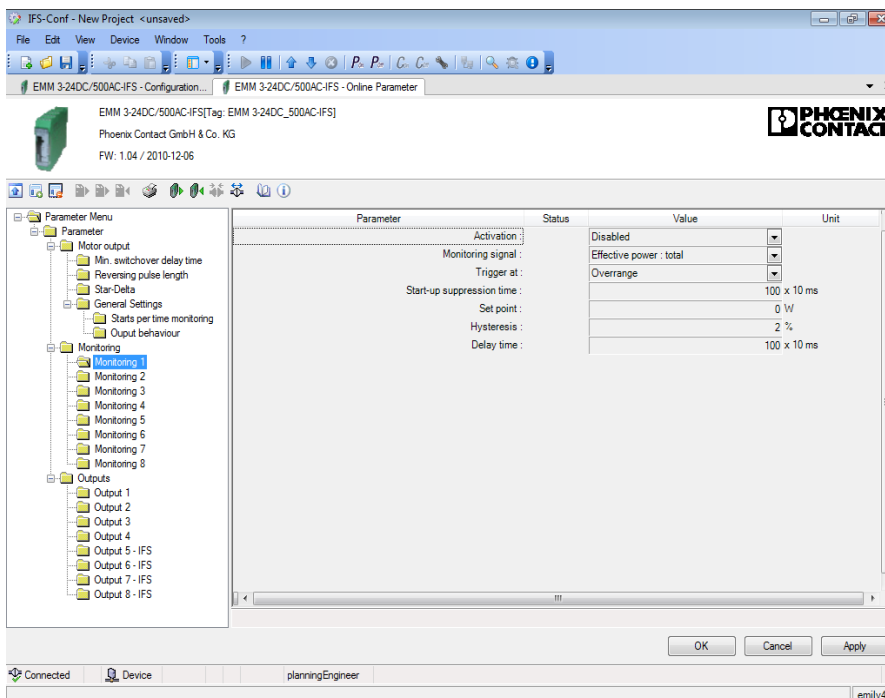

Figure 16-69 “Monitoring 1 ... 8” parameter dialog box

The following parameter data can be set:

Parameter	Selection	Interval	Program side
<b>Activation</b>	– Used from the configuration settings	–	Disabled
<b>Monitoring signal</b>	– Used from the configuration settings	–	Effective power : total
<b>Trigger at</b>	– Used from the configuration settings	–	Overrange
<b>Start-up suppression time</b>	– Min: 0 – Max: 60000	1	100
<b>Set point</b>	– Min: -5000000 – Max: 5000000	1	0
<b>Hysteresis</b>	– Min: 0.1 – Max: 100	0.1	2
<b>Delay time</b>	– Min: 0 – Max: 60000	1	100

## Examples

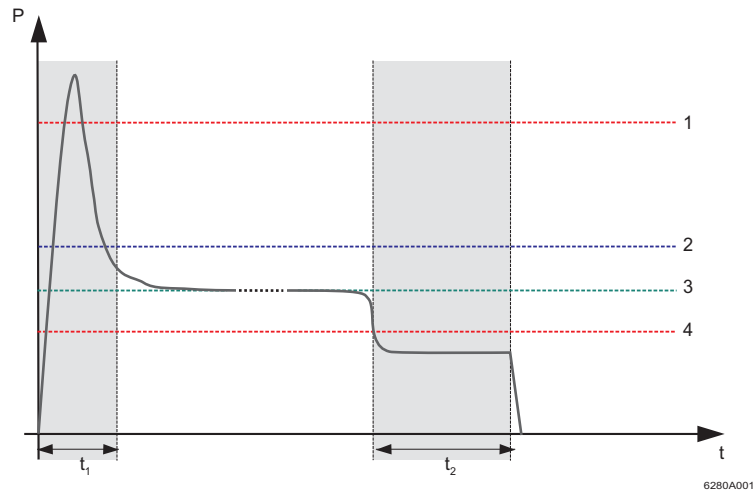

Figure 16-70 Underload example

- P** Real power  
**t** Time  
**t<sub>1</sub>** Start-up suppression time  
**t<sub>2</sub>** Delay time  
**1** Upper performance threshold  
**2** Signaling threshold for filter/screen contamination  
**3** Performance  
**4** Lower performance threshold

Figure 16-70 shows an example of the real power curve for a pump where the real power remains below the lower performance threshold even after a time delay. This may be due to dry running.

## CONTACTRON motor management

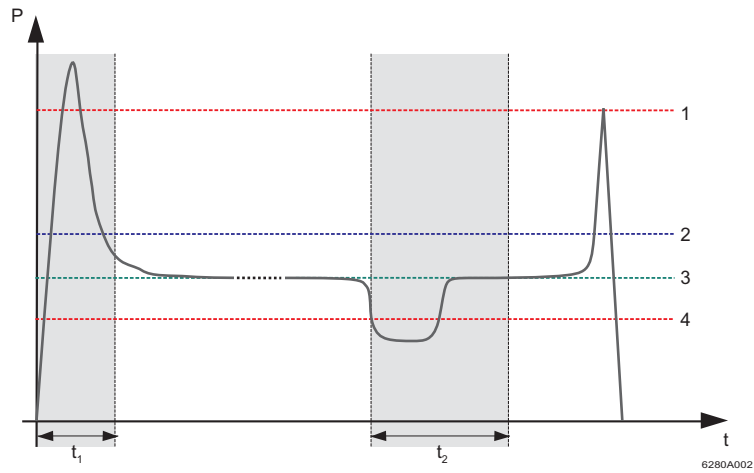

Figure 16-71 Overload example

**P** Real power  
**t** Time  
**t<sub>1</sub>** Start-up suppression time  
**t<sub>2</sub>** Delay time

- 1 Upper performance threshold
- 2 Signaling threshold for filter/screen contamination
- 3 Performance
- 4 Lower performance threshold

Figure 16-71 shows an example of temporary dry running (air bubble in the system). For example, the upper performance threshold is reached in the event of a blockage. The performance level is reached again before the time delay has elapsed.

16.11.2.8 Output 1 ... 8 - IFS

Depending on the selected motor output type (see “Motor output” on page 201), the assignment of the available output signals is fixed. Additional controls for the outputs can be selected individually.



Output signals “Output 5 - IFS” to “Output 8 - IFS” are only available as a status bit in the bus, see Section “EMM objects” on page 44.

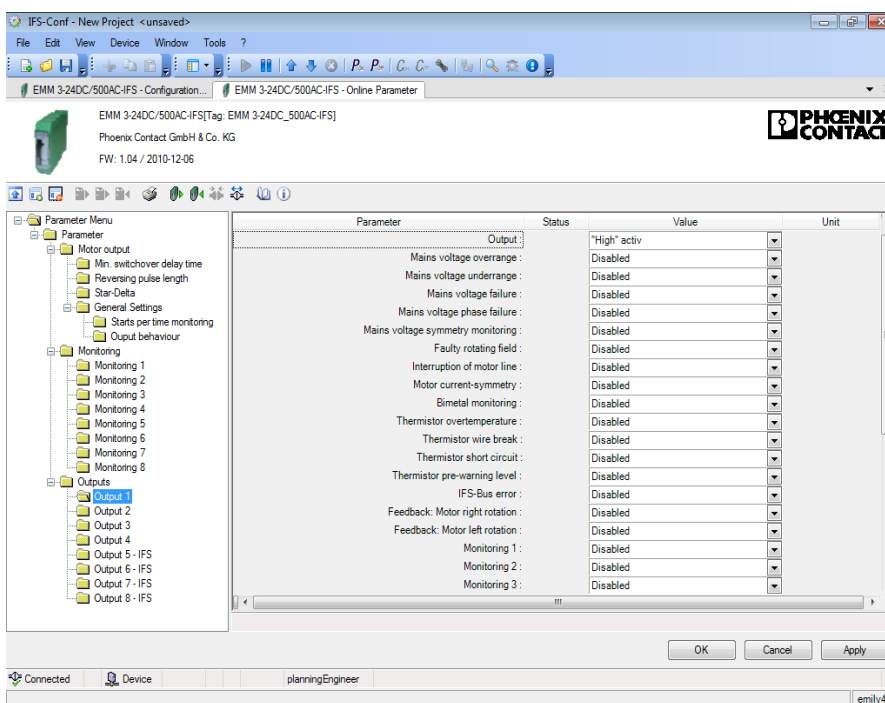

Figure 16-72 “Outputs 1 ... 8” parameter dialog box

The following parameter data can be set:

Parameter	Selection	Interval	Program side
Output	– “High” active – “Low” active	–	“High” active
Mains voltage overrange	– Disabled – Enabled	–	Disabled
Mains voltage underrange	– Disabled – Enabled	–	Disabled
Mains voltage failure	– Disabled – Enabled	–	Disabled
Mains voltage phase failure	– Disabled – Enabled	–	Disabled
Mains voltage symmetry monitoring	– Disabled – Enabled	–	Disabled

**CONTACTRON motor management**

<b>Parameter</b>	<b>Selection</b>	<b>Interval</b>	<b>Program side</b>
<b>Faulty rotating field</b>	- Disabled - Enabled	-	Disabled
<b>Interruption of motor line</b>	- Disabled - Enabled	-	Disabled
<b>Motor current-symmetry</b>	- Disabled - Enabled	-	Disabled
<b>Bimetal monitoring</b>	- Disabled - Enabled	-	Disabled
<b>Thermistor overtemperature</b>	- Disabled - Enabled	-	Disabled
<b>Thermistor wire break</b>	- Disabled - Enabled	-	Disabled
<b>Thermistor short circuit</b>	- Disabled - Enabled	-	Disabled
<b>Thermistor pre-warning level</b>	- Disabled - Enabled	-	Disabled
<b>IFS-Bus error</b>	- Disabled - Enabled	-	Disabled
<b>Feedback: Motor right rotation</b>	- Disabled - Enabled	-	Disabled
<b>Feedback: Motor left rotation</b>	- Disabled - Enabled	-	Disabled
<b>Monitoring 1</b>	- Disabled - Enabled	-	Disabled
<b>Monitoring 2</b>	- Disabled - Enabled	-	Disabled
<b>Monitoring 3</b>	- Disabled - Enabled	-	Disabled
<b>Monitoring 4</b>	- Disabled - Enabled	-	Disabled
<b>Monitoring 5</b>	- Disabled - Enabled	-	Disabled
<b>Monitoring 6</b>	- Disabled - Enabled	-	Disabled
<b>Monitoring 7</b>	- Disabled - Enabled	-	Disabled
<b>Monitoring 8</b>	- Disabled - Enabled	-	Disabled
<b>Execution time at activation</b>	- Disabled - Enabled	-	Disabled

**CONTACTRON-DTM-IFS device drivers**

<b>Parameter</b>	<b>Selection</b>	<b>Interval</b>	<b>Program side</b>
<b>Execution time at deactivation</b>	- Disabled - Enabled	-	Disabled
<b>Response time at activation state</b>	- Disabled - Enabled	-	Disabled
<b>Response time at deactivation state</b>	- Disabled - Enabled	-	Disabled
<b>Error Overcurrent</b>	- Disabled - Enabled	-	Disabled
<b>ShortToGround</b>	- Disabled - Enabled	-	Disabled

## CONTACTRON motor management

### 16.11.3 Writing the configuration to the device

When you write the configuration to the device “Write to device” button, see “Buttons in the DTM toolbar” on page 190), a window appears containing an overview of your configuration.

Clicking “OK” confirms this configuration and the device restarts with this configuration.

Clicking “Cancel” makes the configuration in the device invalid and the devices enters the “invalid configuration” error state. To exit this error state, repeat the write process with a valid configuration and confirm it with “OK”.

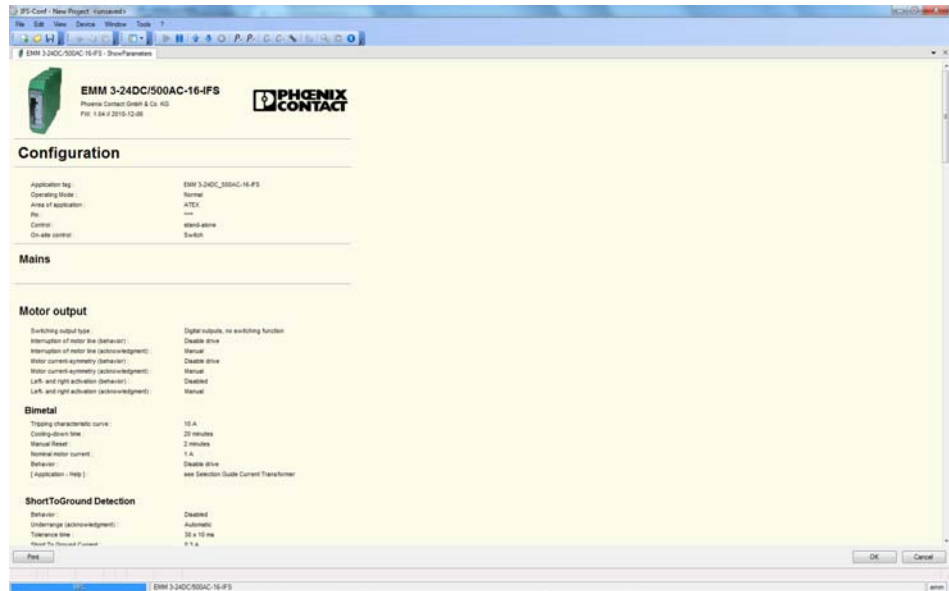









Figure 16-73 Writing the configuration to the device

### 16.11.4 Monitoring dialog box

The current operating values of an electrical drive are checked and recorded via the EMM 3- xx/500AC/xx-IFS module. The monitoring dialog box enables the continuous transfer of data, which can be saved in a separate SGL record file.

This data can be used at a later time, e.g., for diagnostic and optimization purposes.

#### 16.11.4.1 Buttons

Icon	Meaning	Description
	Error acknowledgment	Current error/fault messages are acknowledged.
	Read characteristic curve	Characteristic curve data (SGL format) stored on the service PC are loaded and displayed for diagnostic purposes.
	Manual control	Request for manual operation of the drive (left rotation, stop, right rotation)
	Fast left rotation	Manual request – fast left rotation
	Left rotation	Manual request – left rotation
	Stop	Manual request – stop
	Right rotation	Manual request – right rotation
	Fast right rotation	Manual request – fast right rotation

## CONTACTRON motor management

### 16.11.4.2 Overview

The “Overview” dialog box displays all the operating data and status messages that provide initial information. This dialog box enables a quick and comprehensive overview of the general system state.

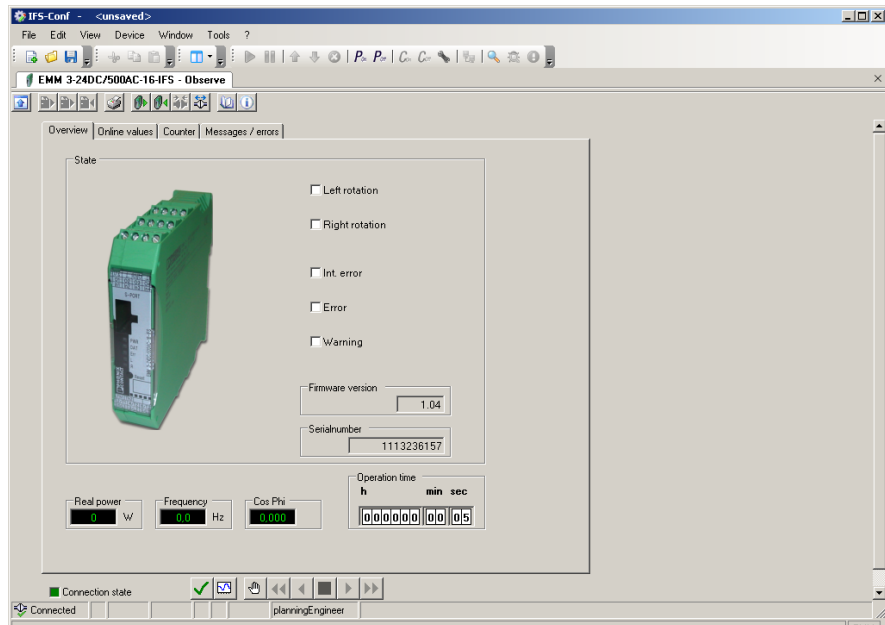





Figure 16-74 “Overview” monitoring dialog box

The following operating data can be determined and displayed:

Status indicator	Meaning	Unit
<b>Left rotation/Right rotation</b>	Status message regarding the current direction of rotation at the output	–
<b>Int. error</b>	Internal error event message is present	–
<b>Error/Warning</b>	Error/warning message is present	–
 (green)	Operating	–
 (yellow)	Warning message	–
 (red)	Error/fault message	–

Numerical display	Meaning	Unit
Real power	Displays the total real power	W
Frequency	Displays the mains frequency	Hz
Cos Phi	Displays the total power factor Cos Phi	–
Operating time	Displays the operating time (data is saved internally on the device)	hhhhhh:mm:ss

### 16.11.4.3 Online values

On this dialog page, all online values are displayed as numerical values. To record a waveform for a display value, move the cursor over the corresponding value and double-click to open scope view (see “Displaying online values as a graph” on page 232).



The total graphs and phase-specific graphs are always displayed for the real power, apparent power, and reactive power (non-active power) online values as well as for the cos phi power factor.

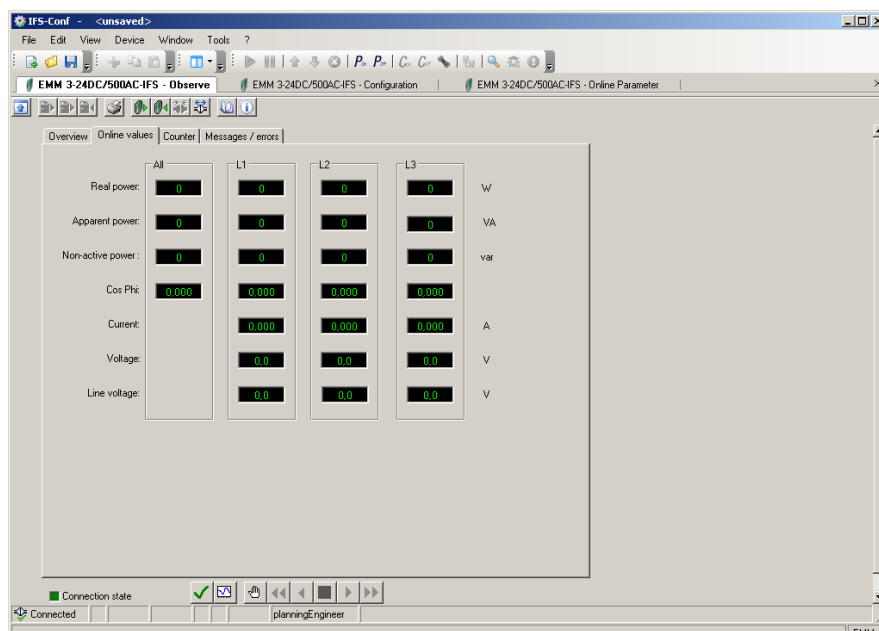

Figure 16-75 “Online values” monitoring dialog box

The following operating data can be determined and displayed:

Numerical display	Meaning	Unit
<b>Real power</b>	Displays the total real power and the phase-specific real power	W
<b>Apparent power</b>	Displays the total apparent power and the phase-specific apparent power	VA
<b>Reactive power (Non-active power)</b>	Displays the total reactive power and the phase-specific reactive power	var
<b>Cos Phi</b>	Displays the total power factor and the phase-specific power factor cos phi	–
<b>Current</b>	Displays the phase-specific line currents	A
<b>Voltage</b>	Displays the phase-specific nominal voltage values	V
<b>Line voltage</b>	Displays the phase-specific line voltage values	V

## CONTACTRON motor management

### Displaying online values as a graph

If you wish, for example, to compare the graphs for the real power of phases L1 ... L3, you can record each of these three components in succession and load the three characteristic curves and the current values in the same scope view. The following information is displayed in scope view:

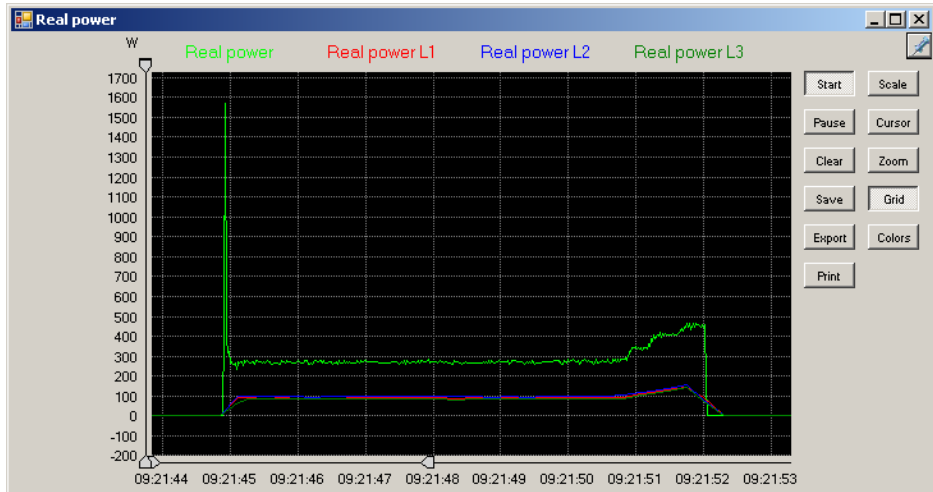





Figure 16-76 Representation of online values

The following functions are executed by clicking on the buttons:

Button	Description
	Clicking the button starts/stops the recording phase.
	Clicking the button interrupts/continues the recording phase.
	Clicking the button deletes the displayed graph. The recording phase is not interrupted.
	Clicking the button calls the "Save As" dialog box. The saved data is automatically assigned the file extension <b>*.sgl</b> .
	Clicking the button calls the "Save As" dialog box. The current graph can be exported as a CSV file.
	Clicking the button returns from a larger detail view to the original view size.
	<p>Clicking the button shows/hides the cursor. The cursor can be used for diagnostic purposes to precisely select a point on the graph and to display the corresponding numerical values.</p> <p>Cursor 1 can be activated by left-clicking on the curve name (in the example: Real power, Real power L1, etc.).</p> <p>Cursor 2 can be activated and the values of Cursor 1 and Cursor 2 compared by right-clicking on the curve name (in the example: Real power, Real power L1, etc.).</p>
	Clicking the button enlarges the area on the Y-axis defined by the two limit markers to fit the entire screen height.

Button	Description
	Clicking the button activates/deactivates the background grid for better orientation on the graph.
	Clicking the button can be used to determine the colors in the scope view preset in the program.
	Clicking the button calls the "Print" dialog box.

**Save graph as...**

Clicking the "Save" button calls the "Save As" dialog box. Enter the required file name according to the Windows conventions.

The curve file is automatically assigned the file extension **\*.sgl**.

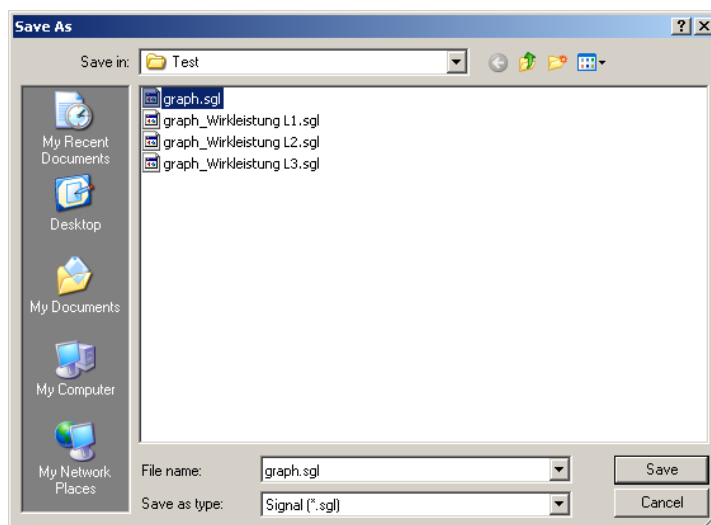

Figure 16-77 Dialog box, save as

## CONTACTRON motor management

### Open graph

Clicking the “Read characteristic curve” button (see “Buttons” on page 229) calls the “Open” dialog box. Here, select the required archive file with the extension \*.sgl. Then, the curve data is loaded and displayed on the service PC for evaluation purposes.

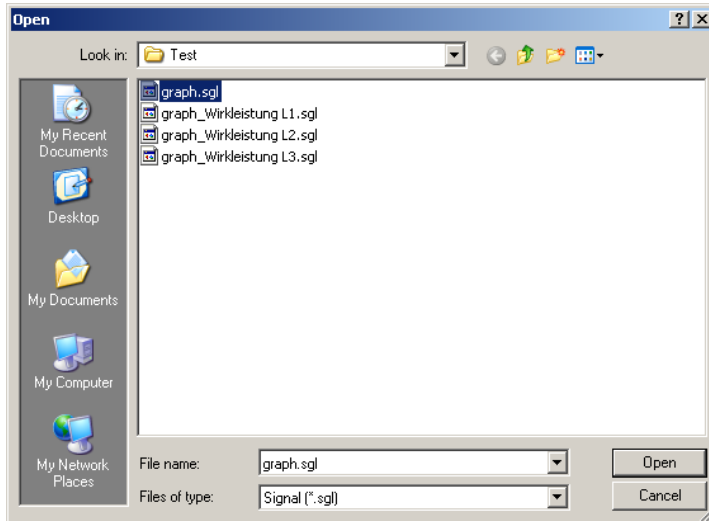

Figure 16-78 Dialog box, open file

### Export curve

Clicking the “Export” button calls the “Save As” dialog box. You can export the current graph as a CSV file.

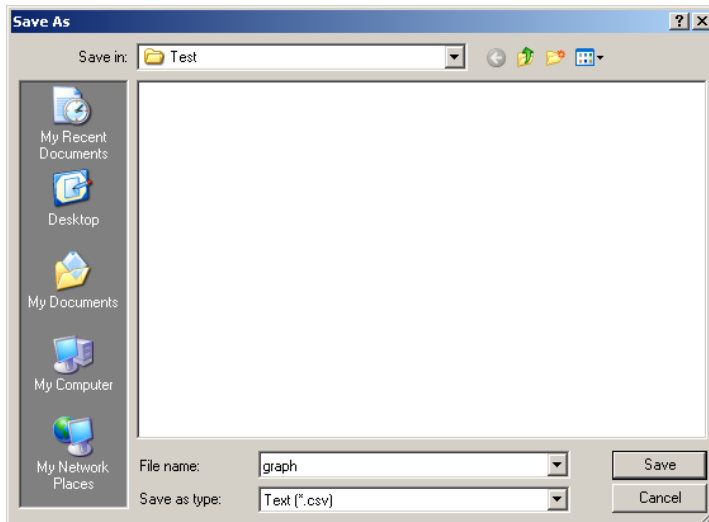

Figure 16-79 Dialog box, export file



The time is saved in the following format in the CSV file: hh:mm:ss,000. This should be noted when importing into Excel.

### 16.11.4.4 Counter

This dialog page provides an overview of the previous operating hours and switching cycles of the connected EMM 3- xx/500AC/xx-IFS. This data is saved internally on the device. You can thus determine various operating values for specific days.



Clicking the relevant “Reset” button resets the corresponding day counter.

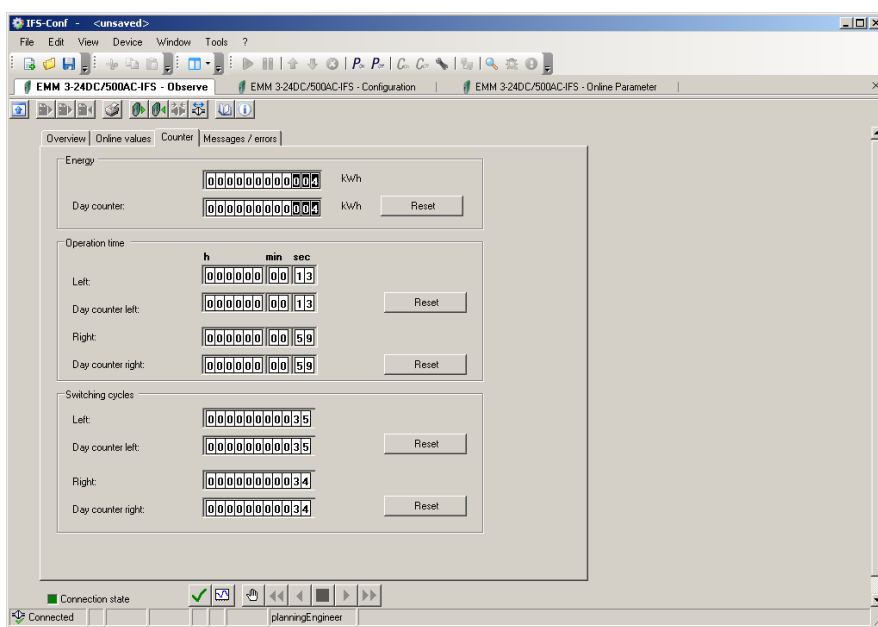

Figure 16-80 “Counter” monitoring dialog box

The following operating data can be determined and displayed:

Numerical display	Meaning	Unit
<b>Energy</b> – Day counter	<b>Display of the total energy used</b> Display of day's energy used	kWh
<b>Operation time</b> – Left – Day counter left – Right – Day counter right	<b>Display of operating times</b> Display of left rotation total counter Display of left rotation day counter Display of right rotation total counter Display of right rotation day counter	hhhh:mm:ss
<b>Switching cycles</b> – Left – Day counter left – Right – Day counter right	<b>Display of switching cycles</b> Display of left rotation total switching cycles Display of left rotation day switching cycles Display of right rotation total switching cycles Display of right rotation day switching cycles	11 digits

**CONTACTRON motor management**

**16.11.4.5 Messages/errors**

This dialog page provides a quick and comprehensive status of the warning and error messages.



Depending on the parameterization, it may be possible that fault messages are displayed fleetingly for the active monitoring item.

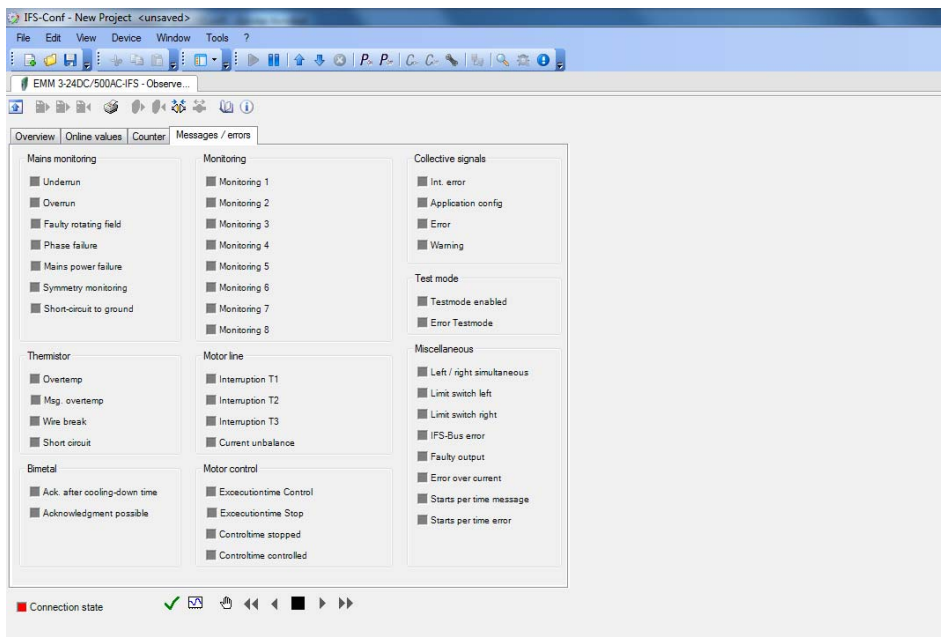

Figure 16-81 “Messages / errors” monitoring dialog box

The following operating data can be determined and displayed:

Display	Meaning
<b>Mains monitoring</b> <ul style="list-style-type: none"> <li>- Underrun</li> <li>- Overrun</li> <li>- Faulty rotating field</li> <li>- Phase failure</li> <li>- Mains power failure</li> <li>- Symmetry monitoring</li> <li>- Short-circuit to ground</li> </ul>	<p>Mains voltage underrange detected (see Section “Voltage monitoring” on page 197)</p> <p>Mains voltage overrange detected (see Section “Voltage monitoring” on page 197)</p> <p>Phase relation on the mains side (direction of rotating field) is not kept</p> <p>Phase failure detected (see Section “Phase monitoring” on page 199)</p> <p>Mains failure detected (see Section “Phase monitoring” on page 199)</p> <p>Uneven load or loss of a phase (see Section “Symmetry monitoring” on page 200)</p> <p>A phase conductor is connected to ground, the EMM 3- xx/500AC/xx-IFS module is disabled</p>
<b>Monitoring</b> <ul style="list-style-type: none"> <li>- Monitoring 1 ... 8</li> </ul>	<p>A parameterized value of monitoring 1 ... 8 is outside its limits (see “Monitoring 1 ... 8” on page 211 and “Monitoring 1 ... 8” on page 222)</p>

## CONTACTRON-DTM-IFS device drivers

Display	Meaning
<b>Collective signals</b> <ul style="list-style-type: none"> <li>– Int. error</li> <li>– Config invalid</li> <li>– Error</li> <li>– Warning</li> </ul>	<p>Send the EMM 3- xx/500AC/xx-IFS module back to the manufacturer. A factory inspection must be performed.</p> <p>Error sending to the device or the process was interrupted.</p> <p>A group error has occurred, e.g., a parameterized trigger threshold has been exceeded.</p> <p>A parameterized signaling threshold has been exceeded.</p>
<b>Test mode</b> <ul style="list-style-type: none"> <li>– Testmode enabled</li> <li>– Error Testmode</li> </ul>	<p>Test mode is activated.</p> <p>An error has been detected in test mode.</p>
<b>Thermistor</b> <ul style="list-style-type: none"> <li>– Overtemp</li> <li>– Msg. overtemp</li> <li>– Wire break</li> <li>– Short circuit</li> </ul>	<p>An impermissibly high operating temperature has been detected in a motor winding.</p> <p>The pre-alarm threshold for triggering a warning message has been reached.</p> <p>An open circuit has been detected in the thermistor cable of a motor winding.</p> <p>A short circuit has been detected in the thermistor cable of a motor winding.</p>
<b>Motor line</b> <ul style="list-style-type: none"> <li>– Interruption T1 ... T3</li> <li>– Current unbalance</li> </ul>	<p>An open circuit has been detected in the motor winding.</p> <p>Asymmetrical current load in the outer conductors</p>
<b>Bimetal</b> <ul style="list-style-type: none"> <li>– Ack. after cooling-down time</li> <li>– Acknowledgment possible</li> </ul>	<p>The parameterized limit values for motor protection were exceeded and resulted in tripping. The message can only be acknowledged after the parameterized cooling time has elapsed (see Section “Bimetal” on page 203).</p> <p>The message can be acknowledged.</p>
<b>Motor control</b> <ul style="list-style-type: none"> <li>– Executiontime Control</li> <li>– Executiontime Stop</li> <li>– Controltime stopped</li> <li>– Controltime controlled</li> </ul>	<p>The execution time for activation has been exceeded.</p> <p>The execution time for stop has been exceeded.</p> <p>The response time for stopped drive has been exceeded.</p> <p>The response time for activation has been exceeded.</p>
<b>Miscellaneous</b> <ul style="list-style-type: none"> <li>– Left / right simultaneous</li> <li>– Limit switch left</li> <li>– Limit switch right</li> <li>– IFS-Bus error</li> <li>– Faulty output</li> <li>– Error overcurrent</li> </ul>	<p>Left and right rotation were requested simultaneously.</p> <p>End position left reached status message</p> <p>End position right reached status message</p> <p>Bus error has been detected between EMM 3- xx/500AC/xx-IFS module and programming adapter or EM-xxx-GATEWAY-IFS</p> <p>For EMM 3- <b>24DC</b>/500AC-xx-IFS modules only:</p> <p>Error indication of the 24 V outputs</p> <p>For EMM 3-xx/<b>500AC-IFS</b> only:</p> <p>If the measured value is greater than 6 A for 9 seconds:</p> <p>“Operational” area of application: Message is generated.</p> <p>“ATEX” area of application: Motor is shut down.</p>

## CONTACTRON motor management

---

# 17 Integration in PC Worx with INTERBUS communication

It is assumed that the user has knowledge of using PC Worx.

## 17.1 System requirements

### Hardware requirements for PC Worx

Please refer to the PC Worx documentation for the hardware requirements.

### Software requirements

Work with the AUTOMATIONWORX Software Suite 2009 Version 1.50 or later Service Pack 3 or PC Worx 6.00 Service Pack 3.

## 17.2 Installing the software and DTM libraries

- Install PC Worx 6.00 Service Pack 3 (part of the AUTOMATIONWORX Software Suite 2009 Version 1.50 or later Service Pack 3) on your PC.  
Follow the installation instructions in the program.



The DTM functions must be activated in PC Worx. Please note that these functions are deactivated if they have not been activated specifically.

- To activate the DTM functions in PC Worx, select “Start, All Programs, Phoenix Contact, AUTOMATIONWORX Software Suite 2009 Version 1.50 or later, Service Programs, Enable DTM Support”.
- **Close PC Worx before you start installing the DTM libraries.**

### Installing the AX DTM Library

The AX DTM Library is also installed with the AUTOMATIONWORX Software Suite 2009 Version 1.50 or later.

There is a setup of the AX DTM Library for new installation and updates available to integrate new devices into the software.

- If the AX DTM Library is already installed on a PC, each additional start of the setup causes an update installation. Only the features that have already been installed on the PC will be updated.
- If the AX DTM Library has not yet been installed on a PC, start of the setup leads to a new installation. The features that have been selected automatically or manually will be installed.

There are two ways to install the DTM for the IB IL IFS-MA-PAC terminal when a library has already been installed:

1. Uninstall the old library. When the next setup is executed all automatically or manually selected features will be installed.
2. The new setup package is installed over the old installation.

## CONTACTRON motor management

Following installation, the newly added features (e.g., the CONTACTRON motor management terminal) are not yet available. To activate the new features, proceed as follows:

- a) Select “Start, Control Panel, Software”.
- b) Select “AX DTM Library”.
- c) Click the “Edit” button.
- d) In the welcome window of the installation wizard click the “Next” (Weiter) button.
- e) In the following “Program Management” window select the “Edit Program” (Programm ändern) menu item and confirm your selection with “Next” (Weiter).
- f) The installation wizard displays all the features available in the setup. The icon in front of an entry shows the status of the feature (hard disk = installed/install; red cross = not installed/remove).

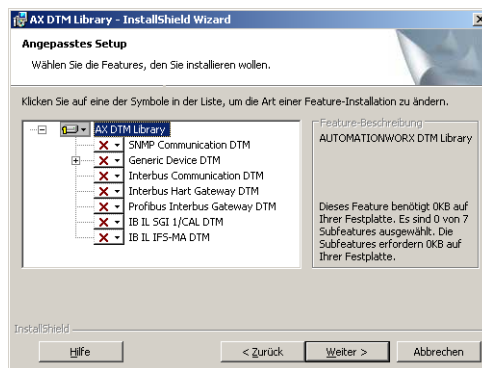

Figure 17-1 Features in the setup

- g) Click the icon in front of the entry to change the status of the feature (e.g., IB IL IFS-MA DTM).



Figure 17-2 Activating a feature

- h) Confirm your selection with “Next” (Weiter).
- i) Complete the installation wizard with “Install”.

### Installing the CONTACTRON DTM

- Install the setup for the CONTACTRON DTM.
- Follow the instructions of the installation wizard.
- In the “Required components...” (Erforderliche Komponenten) window, select the entry highlighted in Figure 17-3.

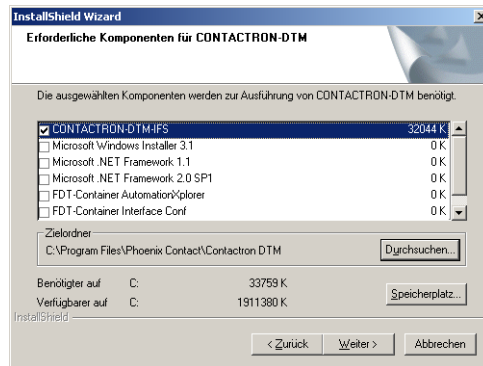

Figure 17-3 CONTACTRON DTM - Selection for CONTACTRON motor management

- Follow the instructions of the installation wizard.

## 17.3 Creating a project and integrating DTMs in PC Worx

The next time PC Worx is started, a window appears indicating the search progress for newly installed DTMs in the registry.

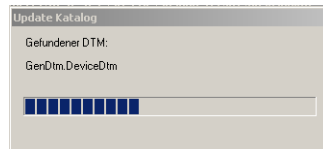

Figure 17-4 Search progress

- Create a new project with the controller used (here: ILC 150 ETH) via the “File, New Project” menu.
- Save the project via “File, Project, Save As” (here: Quickstart\_IFS\_MA).

## CONTACTRON motor management

- Select the “Import from DTM Catalog...” menu item to integrate the detected DTMs into the device catalog.

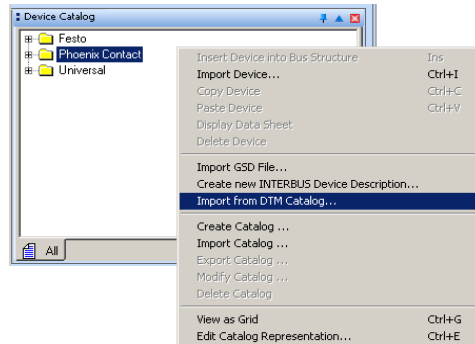

Figure 17-5 Integrating DTMs in the device catalog

The message “Would you like to scan the registry again to detect newly installed DTMs?” appears. Since there has been a registry scan when PC Worx was restarted you can click “No”.

Afterwards you may be asked (several times) for various device descriptions whether the devices in the device catalog are to be replaced. Answer this question with “Yes”.



Do not import any device descriptions manually. If you have imported device descriptions manually, delete them and import them as described above.

The process described applies to DTMs from Phoenix Contact as well as DTMs from other manufacturers.

The PC Worx message window indicates which devices have been imported.

The device catalog now displays all devices sorted according to vendors.



Figure 17-6 Device catalog after import

## 17.4 Reading or inserting devices in the bus configuration

You can read in the local bus automatically or insert it manually. Lower-level EMMs must be inserted manually.

### 17.4.1 Reading in the local bus (IB IL IFS-MA-PAC) automatically



The advantage of reading in is that the read-in device description always corresponds to the data width set with the DIP switches on the terminal.

Requirements:

- The project information was specified
- The IP settings for the controller have been checked/modified
- The IP address for the controller was assigned
- Make sure you are in the bus configuration workspace.
- Select the “View, Connected Bus” menu.

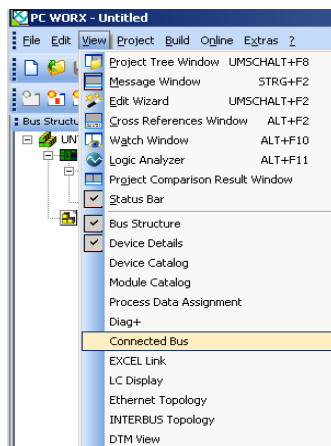

Figure 17-7 View, Connected Bus

- Select the control system in the window that opens.



You are notified if there is a project on the controller and the configuration frame is different. In this case, activate the “Create Configuration Frame” item in the “Connected Bus” window of the context menu of the controller.

## CONTACTRON motor management

The connected bus will be displayed.

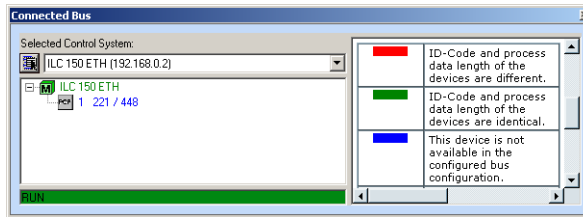

Figure 17-8 Connected bus

- Import the IB IL IFS-MA-PAC terminal into the project.

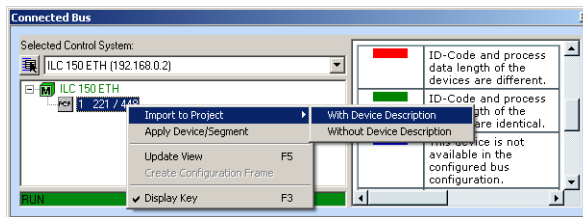

Figure 17-9 Importing the device into the project

- Import the IB IL IFS-MA-PAC terminal into the project.

The terminal has been read into the bus configuration.

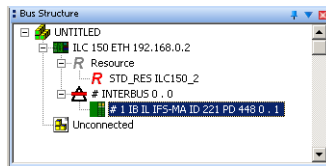

Figure 17-10 Local bus read in

## 17.4.2 Inserting the IB IL IFS-MA-PAC manually



The ID code and data width on the local bus are set with the DIP switches on the IB IL IFS-MA-PAC terminal. There are different device descriptions available according to this setting.

- Select the corresponding device description for the CONTACTRON motor management terminal according to the ID code (ID) and process data length (PD). You will find the terminal under the vendor Phoenix Contact.

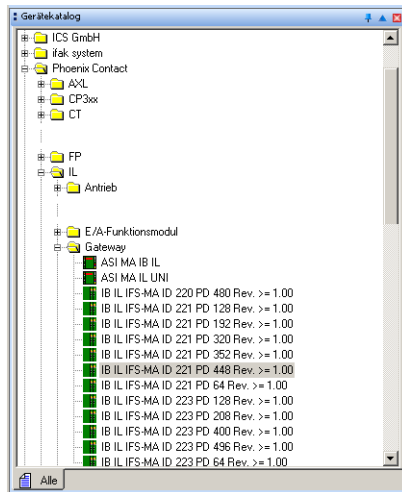

Figure 17-11 Selecting the Interface master with a correct ID/PD

- Insert the IB IL IFS-MA-PAC terminal below the “INTERBUS” node for the controller in the bus configuration.

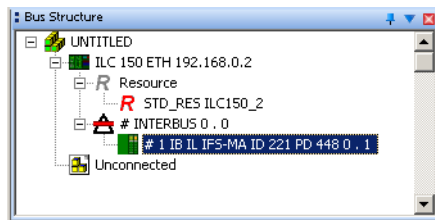

Figure 17-12 Bus configuration with IB IL IFS-MA-PAC

## CONTACTRON motor management

### 17.4.3 Inserting lower-level devices manually

- Select the first lower-level device (EMM...). The EMMs can be found under the vendor Phoenix Contact GmbH & Co. KG.

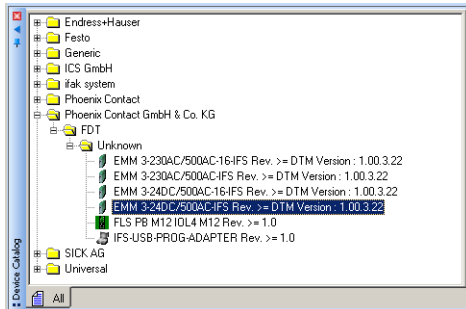

Figure 17-13 Selecting the EMM

- Insert the first device into the lower level under the CONTACTRON motor management terminal ( ).
- Insert the next device into the same level under the previous EMM ( ).

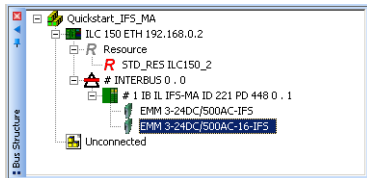

Figure 17-14 Complete bus configuration

- Select “View, DTM View” to display the DTM View window if it is not shown.
- Assign a tag and a device address to the EMMs in the “DTM View” window.

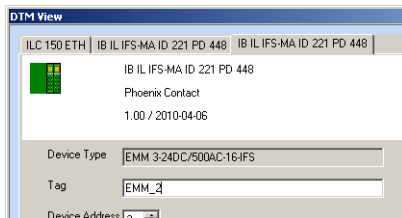

Figure 17-15 Assigning a device address for EMMs

- Confirm your selection with OK.

## 17.5 Compiling the project and downloading it to the controller

- Compile the project.
- Download the project to the controller.
- Perform a cold restart.

## 17.6 Calling DTM functions

- To call the DTM functions of a device, select the “DTM Functions” item in the context menu (right click) and then the desired function.

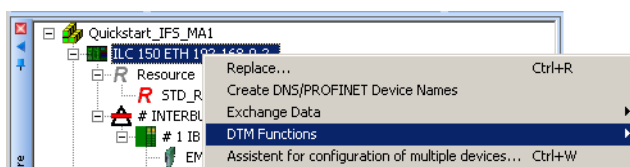

Figure 17-16 Calling DTM functions

### 17.6.1 General DTM functions

#### Connect

Establishes the connection to the DTM device.

#### Disconnect

Disconnects the connection to the DTM device.

Connected devices are displayed with a connection symbol.

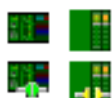

Figure 17-17 Connection symbols (top: devices not connected, bottom left: device actively connected, bottom right: device connected)

The connection symbol on the IB IL IFS-MA-PAC only changes to green (active connection) if another DTM function is selected on this device.

## CONTACTRON motor management

### 17.6.2 DTM functions of the controller

- To use the DTM functions of the controller, connect the controller.



Figure 17-18 DTM functions of the controller

#### Options

The options for the communication path are displayed and can be modified, if required. Make sure that the options in this window and in the "Communication" window of the controller match.

#### Diagnostics

Diagnostic information for the DTM communication path is made available. You have the same DTM functions available as in Diag+.

If "Demo Mode" is displayed under "View" the license key for Diag+ has not yet been entered.

#### Device list

The list of connected DTM devices is displayed and can be modified, if required (e.g., entering the FDT identifier).

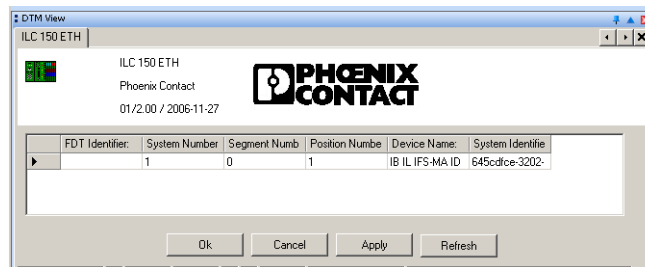

Figure 17-19 DTM functions: Controller device list

### 17.6.3 DTM functions of the IB IL IFS-MA-PAC

- To use the DTM functions of the controller, connect the IB IL IFS-MA-PAC terminal.



Figure 17-20 DTM functions of the IB IL IFS-MA-PAC



The order of possible functions does not correspond to the order of execution. Please proceed in the order as described in this documentation.



For a description of the main functions, please refer to Section “DTM functions” on page 249.

## 17.7 DTM functions

### 17.7.1 Naming lower-level devices

- Open the context menu (right click) and select the menu item – “DTM Function, Device List”.

The list of connected DTM devices will be displayed.

- Modify the information as necessary (e.g., device address, tag).  
Make sure that every device address is assigned only once.

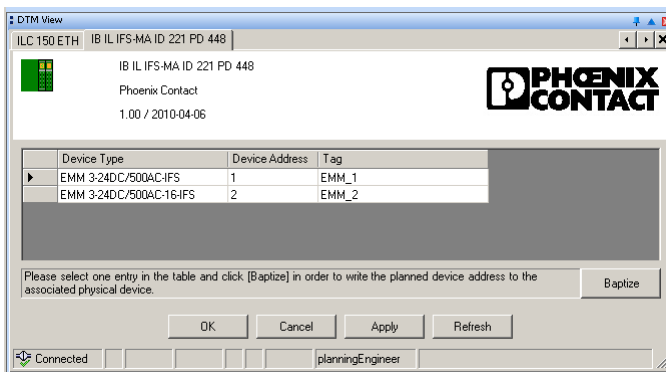

Figure 17-21 CONTACTRON motor management device list

- Select the first device for naming to write the configured device address to the corresponding device.

## CONTACTRON motor management

---

Please select one entry in the table and click [Baptize] in order to write the planned device address to the associated physical device.

Figure 17-22 Start the naming process

Information on the individual steps is given in the information window.

- Activate the “Name” (Baptize) button. This starts the initialization phase.

Initializing Baptize Sequence.

Figure 17-23 Initializing the device naming process

- Wait until you are prompted to write in the information window.

Please confirm writing the device address by pressing the button at the intended physical device within the next 17 seconds.

Figure 17-24 Time remaining for naming

- Press the reset button on the corresponding device to write the device address to the device. The time remaining for this process will be displayed in the information window.

All LEDs on the EMM light up briefly when the address has been written successfully to the EMM. Successful naming is shown in the software.

The device address has been set successfully.

Figure 17-25 Naming carried out successfully

- Name the second device as well.

If the naming was not successful, the following message appears:

You did not confirm writing the device address or an error during communication with the device encountered.

Figure 17-26 Naming has not been carried out

### PC Worx



A peripheral fault (I/O error) is indicated on the controller when the naming starts (PF LED is on). Reset this error after all devices have been named successfully.

- To do this, select “View, Diag+” or the “DTM Functions, Diagnostics” context menu at the controller node.
- Diag+: Connect the communication path to the ILC 150 ETH (in Diag+).  
DTM Functions, Diagnostics: The DTM communication path is set automatically.
- Select the “INTERBUS Diagnostics” view.
- Select the “Actions” tab.
- Click the “Confirm Diagnostics” button or the “Acknowledge all Peripheral Faults” button.

## 17.7.2 Assigning process data

Assign the process data between the EMMs and the CONTACTRON motor management here.

- Open the context menu (right click) of the IB IL IFS-MA-PAC terminal and select the menu item
  - “DTM Functions, Process Data Configuration”.
- Select the INTERBUS Input Data tab to define the process data of the lower-level devices to the CONTACTRON motor management terminal.
- Under IFS Systems, select the EMM of which you want to use the process data (here: EMM\_1).
- Under IFS Process Data, select the process data item that you want to use (here: EMM : STATE).
- Under INTERBUS Process Data, select the process data item to which the IFS process data is to be mapped.
- Select the “Connect” item in the context menu of this process data item.

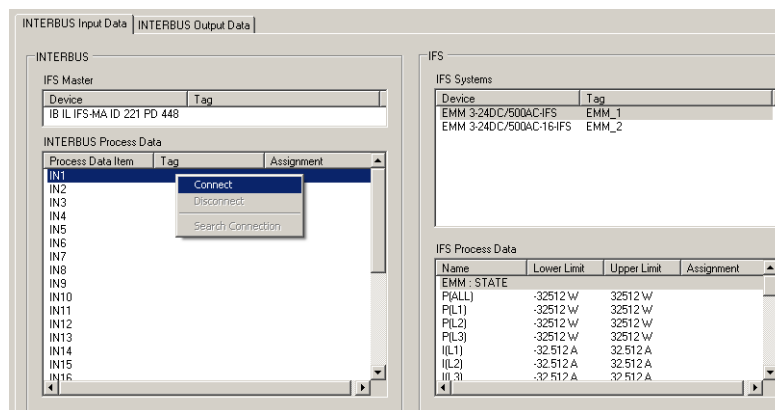

Figure 17-27 Connecting process data

## CONTACTRON motor management

- Repeat this procedure for all other process data.

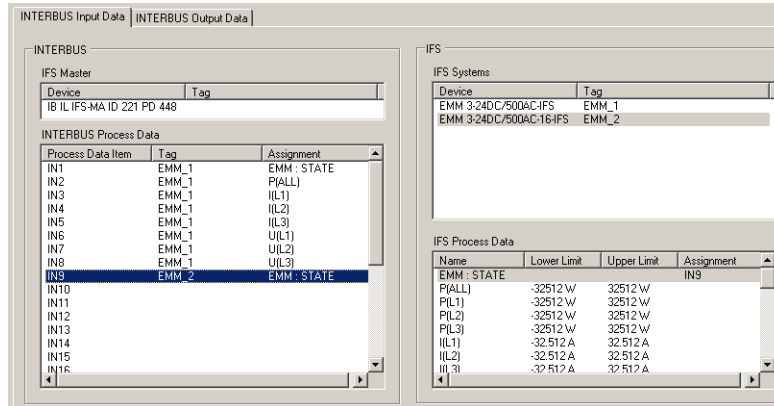

Figure 17-28 INTERBUS input data is connected

- Complete the process with “Apply”.
- Select the INTERBUS Output Data tab to define the process data from the IB IL IFS-MA-PAC terminal to the lower-level devices.
- Please proceed as described for the INTERBUS input data.

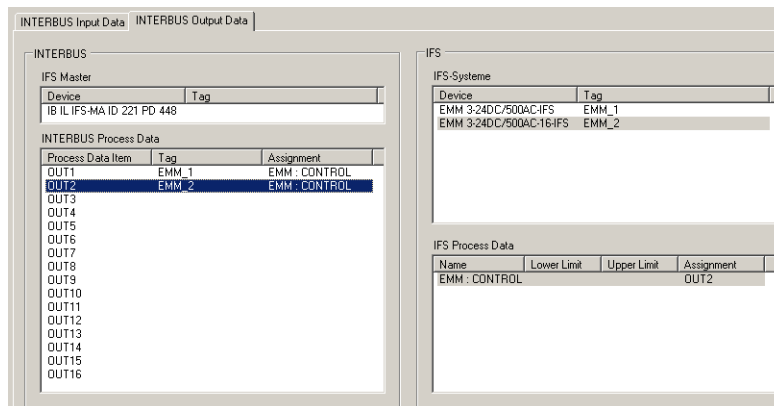

Figure 17-29 INTERBUS output data is connected

### 17.7.3 Downloading the parameters

- Open the context menu (right click) of the IB IL IFS-MA-PAC terminal and select the menu item
  - “DTM Functions, Download Parameters” (PC Worx).

The progress bar shows the transmission status. After the download has been completed, the process data can be read from or written to the controller.

### 17.7.4 Displaying, monitoring, specifying data of an EMM

- You have to establish a connection to the EMM in order to use the data of an EMM. To do so, select in the context menu of the EMM
  - “DTM Functions, Connect”.
- Select for example
  - “FDT Functions, Monitor”.

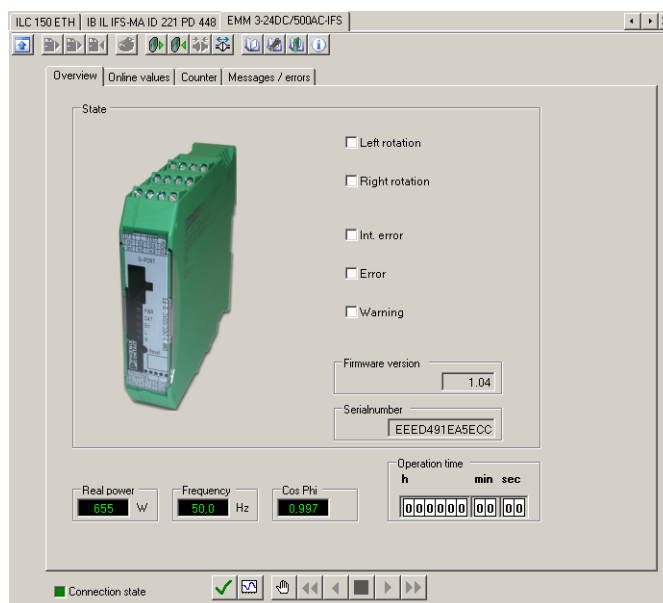

Figure 17-30 Displayed data of an EMM - Overview

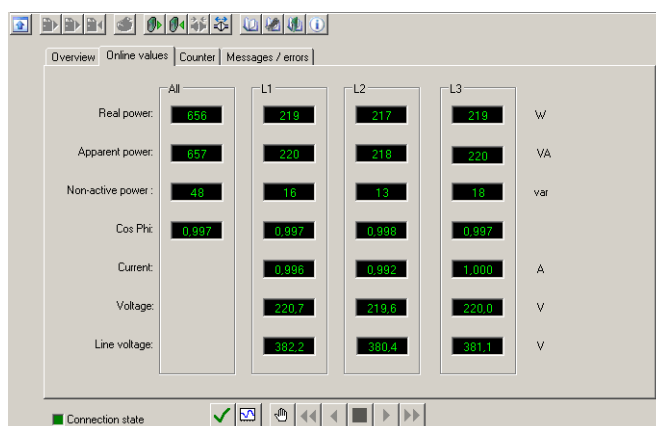

Figure 17-31 Displayed data of an EMM - Online values

- To make settings on the EMM, select the following in the context menu of the EMM
  - “DTM Functions, Options”.

CONTACTRON motor management

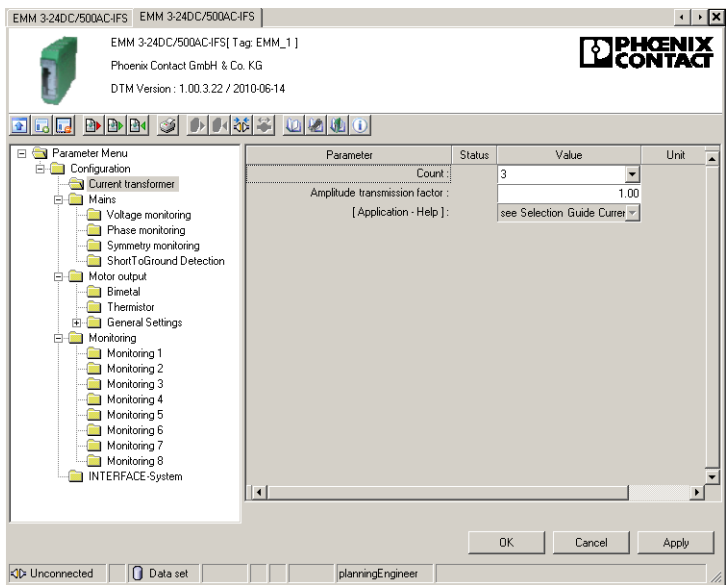



Figure 17-32 EMM options

- Select “Offline Parameters” (  icon in the menu bar) in the context menu of the EMM to configure and parameterize the EMM during configuration, even if it is not actually connected.

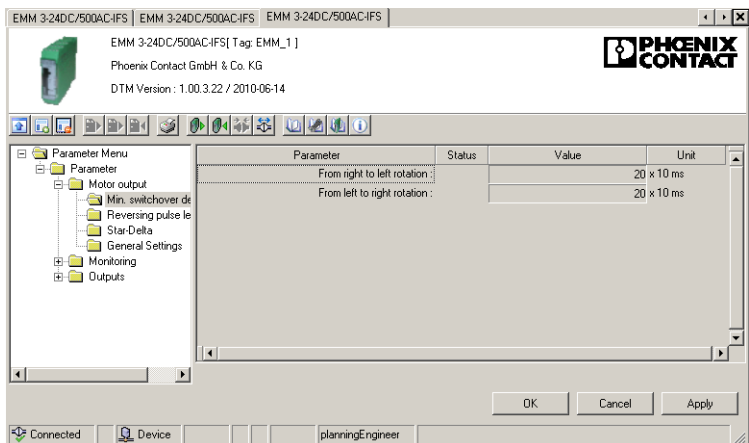

Figure 17-33 Offline parameters

# 18 Integration in STEP 7 with PROFIBUS communication

It is assumed that the user has knowledge of using Siemens STEP 7.

## 18.1 Flow chart

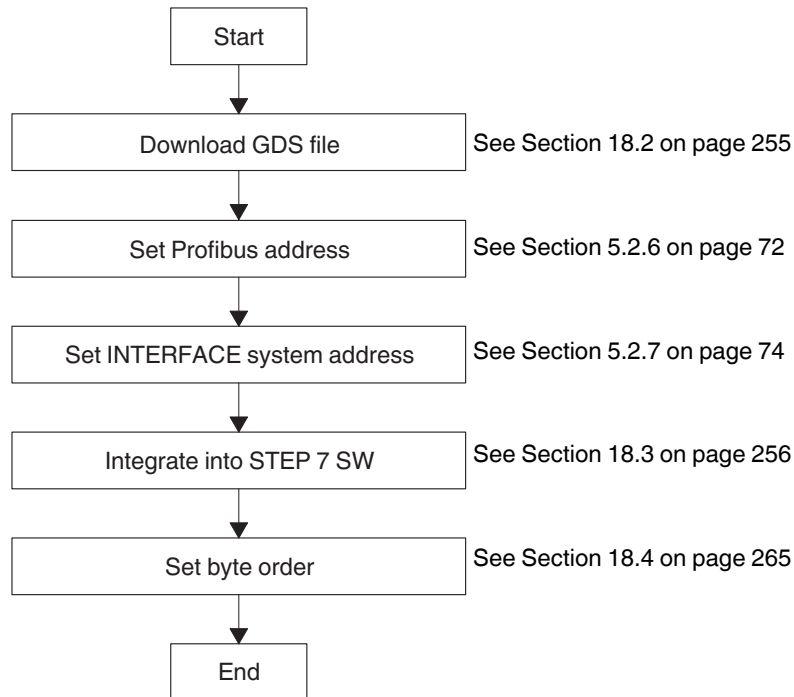

Figure 18-1 Flow chart

## 18.2 Downloading the GSD file

1. Access the Phoenix Contact online catalog ([phoenixcontact.net/products](http://phoenixcontact.net/products)) and search for "EM-PB-GATEWAY-IFS" or "2297620".
1. Select "Downloads".

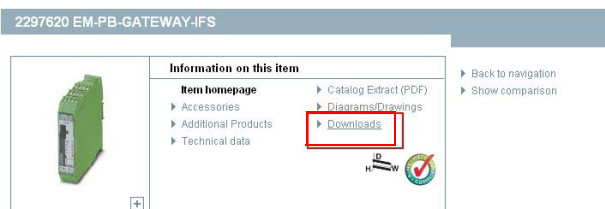

Figure 18-2 Selecting "Downloads" in the online catalog

## CONTACTRON motor management

- Click on GSD file "PXC\_0B51.gsd".

Software				
Description	Language	Revision	File size [bytes]	Type
GSD file for EM-PB-GATEWAY-IFS	Internatio	1.02	19028	gsd
PXC_0B51.gsd				
CONTACTRON-DTM-IFS setup (DTM version 3.14, Automation Explorer, USB driver)	German English	1.00.3.14	83165357	zip
▶ ContactronDtmSetup.zip				

Figure 18-3 Selecting the GSD file in the online catalog

- Read the General Terms and Conditions of Use.
- Click "Accept" to confirm that you agree with the General Terms and Conditions of Use.

Before downloading the files, please accept the  
General Terms and Conditions for Use of Internet Downloads.



Figure 18-4 General terms and conditions of use

- Click "OK" to save the GSD file.

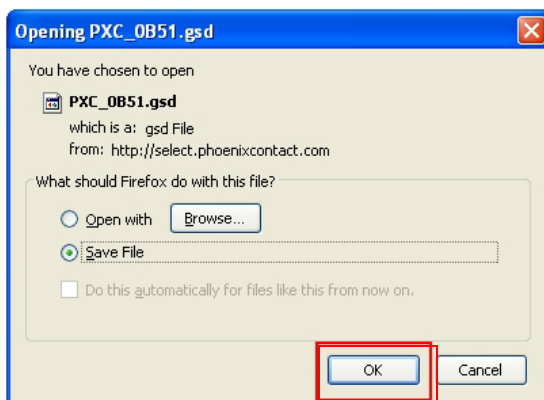

Figure 18-5 Saving the GSD file

## 18.3 Integration in STEP 7

- Start SIMATIC Manager.



SIMATIC  
Manager

Figure 18-6 SIMATIC Manager icon

- Create a new project.

## Integration in STEP 7 with PROFIBUS communication

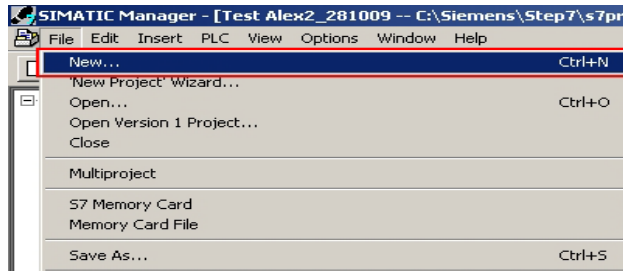

Figure 18-7 Creating a new project

3. Assign a project name and click “OK”.

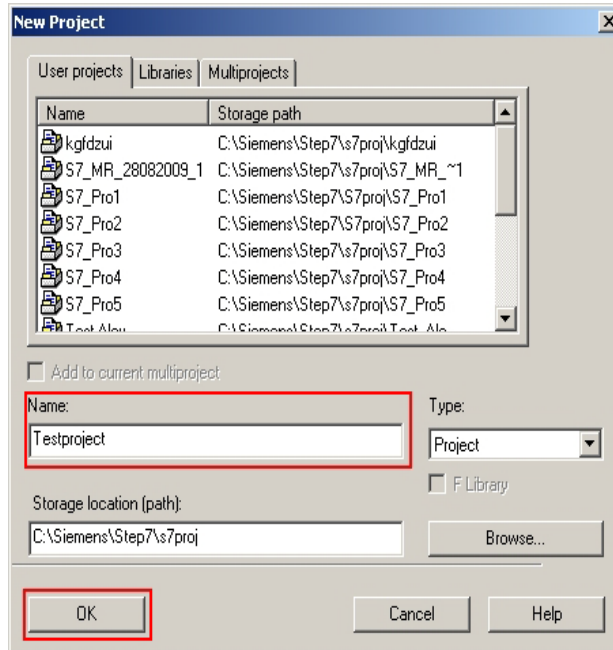

Figure 18-8 Saving the project name

## CONTACTRON motor management

4. Select the appropriate CPU in the “Insert, Station” menu.

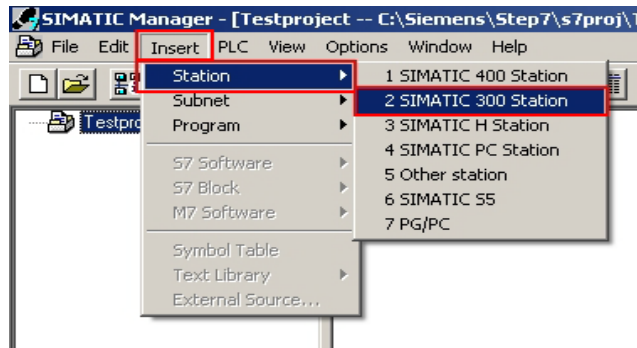

Figure 18-9 Selecting the CPU

5. The selected CPU is inserted in your project.

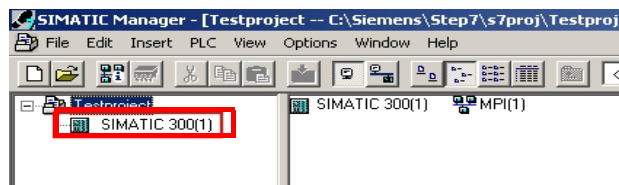

Figure 18-10 Selected CPU

6. Open the context menu of the inserted CPU.  
7. Click on “Open Object”.

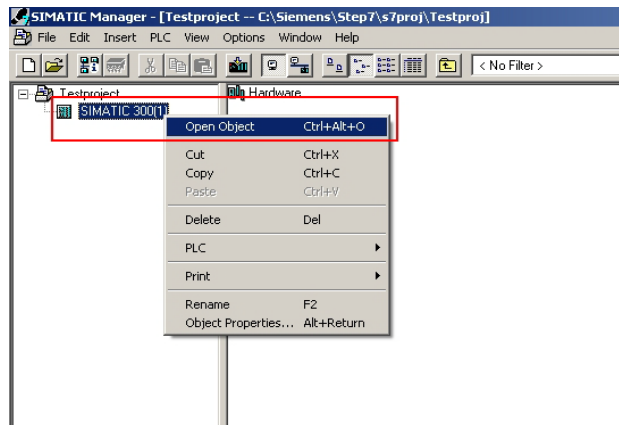

Figure 18-11 Opening the object

## Integration in STEP 7 with PROFIBUS communication

8. The hardware configuration is displayed.

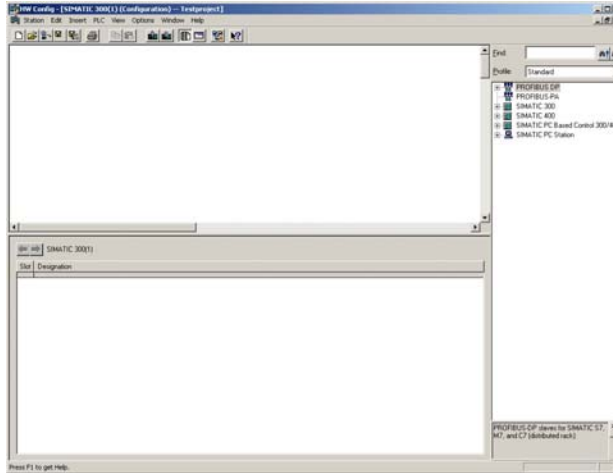

Figure 18-12 Hardware configuration

9. Close all application windows.



Figure 18-13 Hardware configuration

10. Select “Options, Install New GSD...”.

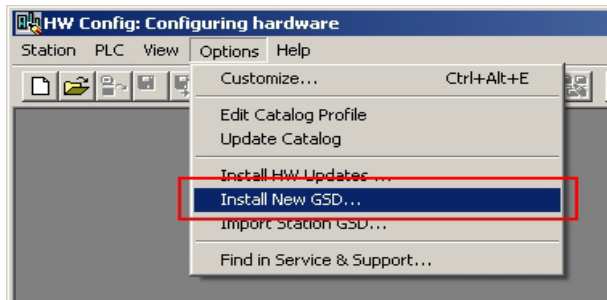

Figure 18-14 Installing a GSD file

## CONTACTRON motor management

11. Now load the GSD file downloaded in Section 18.2.
12. If the message “Die Installation wurde erfolgreich beendet” (“Installation has been completed successfully”) appears, you can close the hardware editor.



Figure 18-15 “Die Installation wurde erfolgreich beendet” (“Installation has been completed successfully”) message

13. Open the context menu of the inserted CPU.
14. Click on “Open Object”.

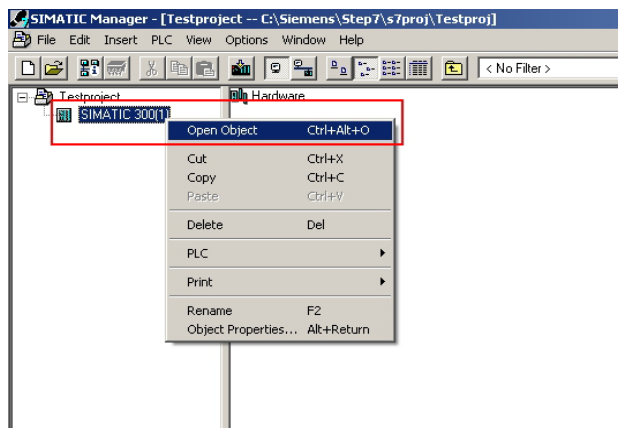

Figure 18-16 Opening the object

15. Select “View, Catalog”.

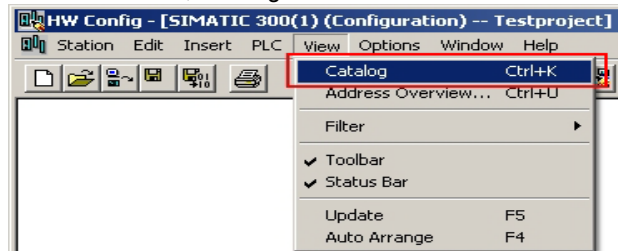

Figure 18-17 Selecting the catalog

## Integration in STEP 7 with PROFIBUS communication

16. The catalog window appears.

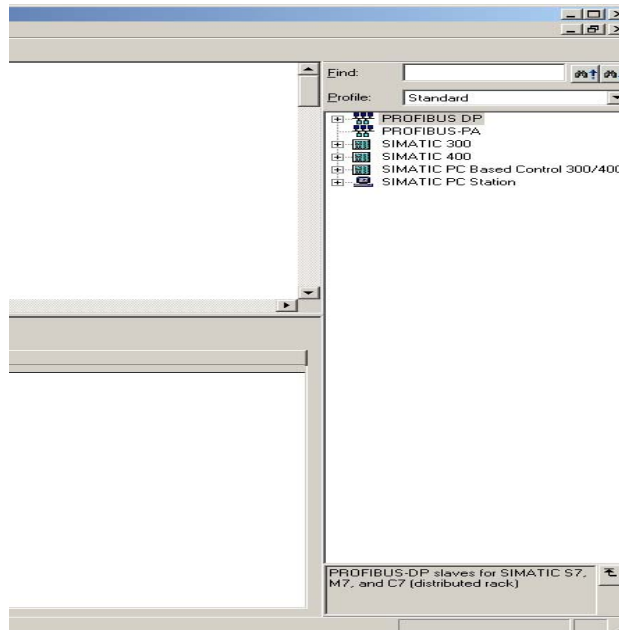

Figure 18-18 Catalog window

17. Suitable devices must be inserted in your project here.

### 18.3.1 Example with SIMATIC 300

1. Select “SIMATIC 300, RACK-300, Rail” and insert this in your project.

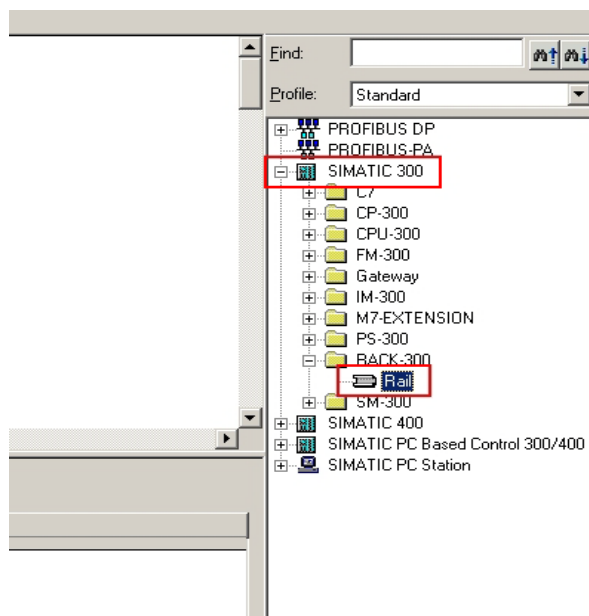

Figure 18-19 Selecting the DIN rail

## CONTACTRON motor management

2. Select “SIMATIC 300, CPU 315-2 DP, 6ES7-315-2AF03-0AB0, V1.2” and insert this in your project.

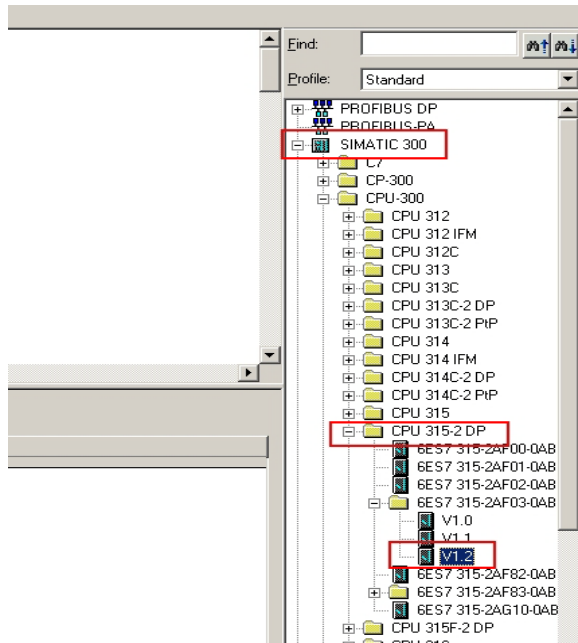

Figure 18-20 Selecting the CPU

3. The “Properties” window appears.  
Click “New” and enter a new name for the bus line.

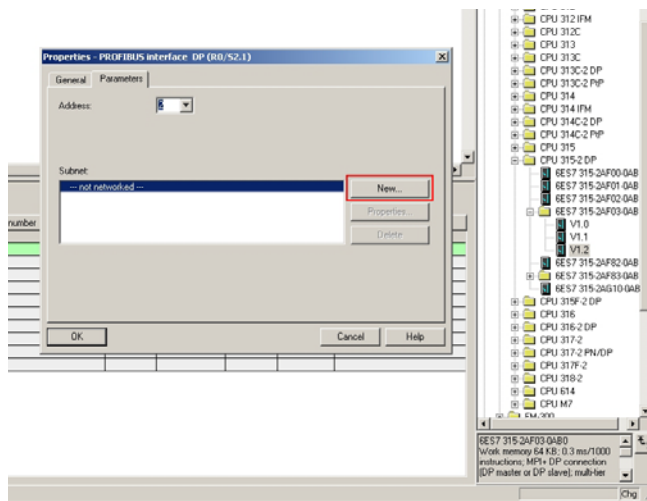

Figure 18-21 Bus line name

4. Select “PROFIBUS DP, Additional Field Devices, Gateway”.  
Now move the EM-PB-GATEWAY-IFS into your project.

Integration in STEP 7 with PROFIBUS communication

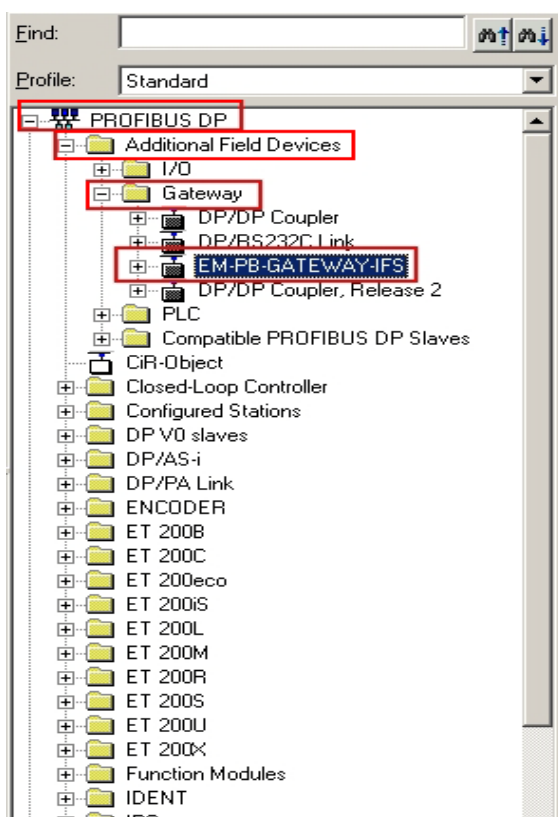

Figure 18-22 Selecting the gateway

- The "Properties" window appears. Under "Address", you must select the address that was configured in the EM-PB-GATEWAY-IFS in Section 5.2.6.

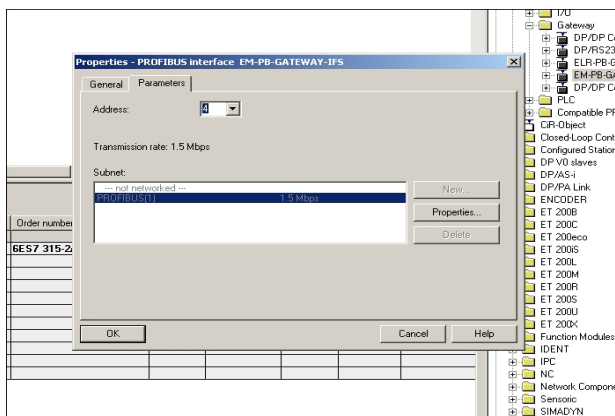

Figure 18-23 Gateway properties

- You can now move the required GSD data to your project from the catalog window under the "EM-PB-GATEWAY-IFS" item.

## CONTACTRON motor management

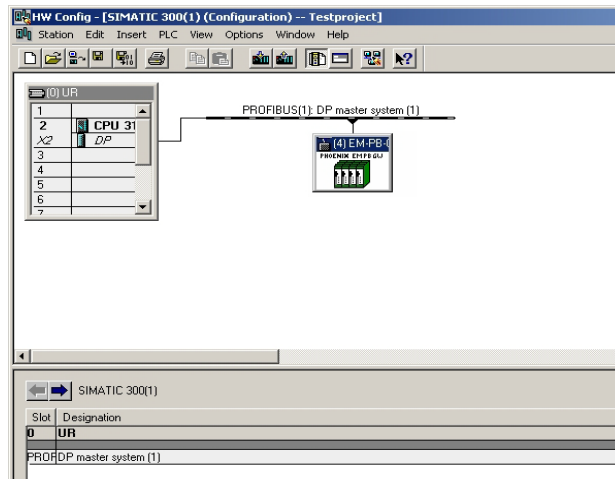

Figure 18-24 GSD data

## 18.4 Setting the byte order

1. Open the context menu of the EM-PB-GATEWAY-IFS and select “Object Properties”.
2. Open the “Parameter Assignment” tab.

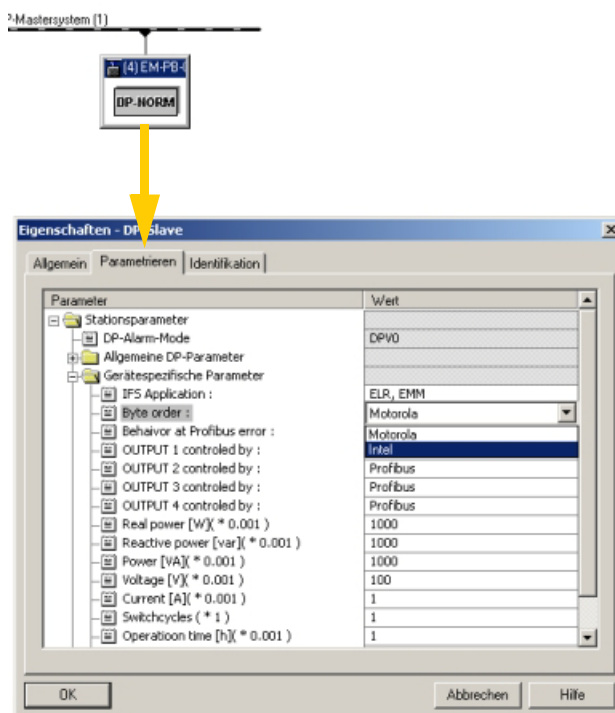

Figure 18-25 Setting the byte order

3. The byte order of the transferred data can be set here under “Device-specific parameters, Byte order”.

**Motorola:** Big Endian (the high byte is saved first)  
**Intel:** Little Endian (the low byte is saved first)

**Example: Value “EMM: COS  $\varphi$ ”**

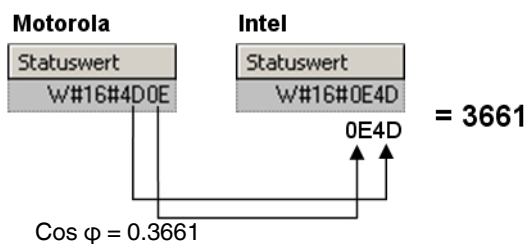

Figure 18-26 Example: Value “EMM: COS  $\varphi$ ”

## 18.5 Explanation of GSD data

### 18.5.1 GSD data for EM-PB-GATEWAY-IFS



For a detailed description of the GSD data, please refer to Section 5.3.2, "Structure of the diagnostic telegram", Section 3.1.1, "Digital input and output", Section 3.1.2, "Module status", and Section 3.1.3, "Station status".

Universal module
Digital inputs, outputs
Gateway: Module state
Gateway: Channel State 1
Gateway: Channel State 2
Gateway: Channel State 3
Gateway: Channel State 4
IFS: Slave Error State 1
IFS: Slave Error State 2
IFS: Periphery State 1
IFS: Periphery State 2

### 18.5.2 GSD data for EMM ... IFS



For a detailed description of the GSD data, please refer to Section 3.1.4, "EMM objects" and Section 3.2.1, "Available measured values".

ELR, EMM Objects =====	
EMM: Control (Device:1)	1 = IFS address 1
EMM: Control (Device:2)	2 = IFS address 2
EMM: Control (Device:3)	3 = IFS address 3
EMM: Control (Device:4)	4 = IFS address 4
EMM: Control (Device:5)	5 = IFS address 5
EMM: Control (Device:6)	6 = IFS address 6
EMM: Control (Device:7)	7 = IFS address 7
EMM: Control (Device:8)	8 = IFS address 8
EMM: Status	
EMM: Module State 1	

---

**Integration in STEP 7 with PROFIBUS communication**

---

EMM: Module State 2
EMM: Channel State 1
EMM: Channel State 2
EMM: Channel State 3
EMM: Channel State 4
EMM: P(ALL)
EMM: U(L1)
EMM: U(L2)
EMM: U(L3)
EMM: I(L1)
EMM: I(L2)
EMM: I(L3)
EMM: Electric Work
EMM: COS PHI
EMM: Frequency
EMM: Operation time (left)
EMM: Operation time (right)
EMM: Cycle (left)
EMM: Cycle (right)
EMM: P(L1)
EMM: P(L2)
EMM: Q(ALL)
EMM: S(ALL)
EMM: $\text{SQRT}(3) * U(L1)$
EMM: $\text{SQRT}(3) * U(L2)$
EMM: $\text{SQRT}(3) * U(L3)$

## 18.6 Example

The following modules are used in this example:

- SIMATIC S7-300
- EM-PB-GATEWAY-IFS
- EMM 3- 24DC/500AC-16-IFS

### 18.6.1 Hardware structure

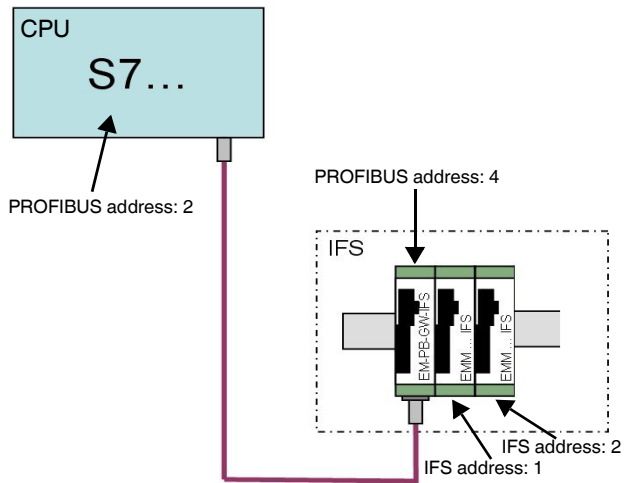

Figure 18-27 Hardware structure

### 18.6.2 GSD values used



Order Number / Designation
Digital inputs, outputs

Inputs and outputs of the EM-PB-GATEWAY-IFS



Order Number / Designation
EMM : Control (Device:1)
EMM : Status
EMM : P[ALL]
EMM : Frequency
EMM : Operation time(left)
EMM : Operation time(right)
EMM : Cycle(left)
EMM : Cycle(right)
EMM : U(L1)
EMM : U(L2)
EMM : U(L3)
EMM : I(L1)
EMM : I(L2)
EMM : I(L3)

Control word of the EMM, e.g., right rotation, left rotation, stop, reset, etc.  
 Status word of the EMM, e.g., input state, direction of motor  
 Display: Total real power  
 Display: Frequency  
 Display: Operating hours counter (left rotation)  
 Display: Operating hours counter (right rotation)  
 Display: Switching cycles (left rotation)  
 Display: Switching cycles (right rotation)  
 Display: Voltage L1  
 Display: Voltage L2  
 Display: Voltage L3  
 Display: Current L1  
 Display: Current L2  
 Display: Current L3



Order Number / Designation
EMM : Control (Device:2)
EMM : Status
EMM : P[ALL]
EMM : Frequency
EMM : Operation time(left)
EMM : Operation time(right)
EMM : Cycle(left)
EMM : Cycle(right)
EMM : U(L1)
EMM : U(L2)
EMM : U(L3)
EMM : I(L1)
EMM : I(L2)
EMM : I(L3)

Control word of the EMM, e.g., right rotation, left rotation, stop, reset, etc.  
 Status word of the EMM, e.g., input state, direction of motor  
 Display: Total real power  
 Display: Frequency  
 Display: Operating hours counter (left rotation)  
 Display: Operating hours counter (right rotation)  
 Display: Switching cycles (left rotation)  
 Display: Switching cycles (right rotation)  
 Display: Voltage L1  
 Display: Voltage L2  
 Display: Voltage L3  
 Display: Current L1  
 Display: Current L2  
 Display: Current L3

CONTACTRON motor management

18.6.3 Monitoring variables

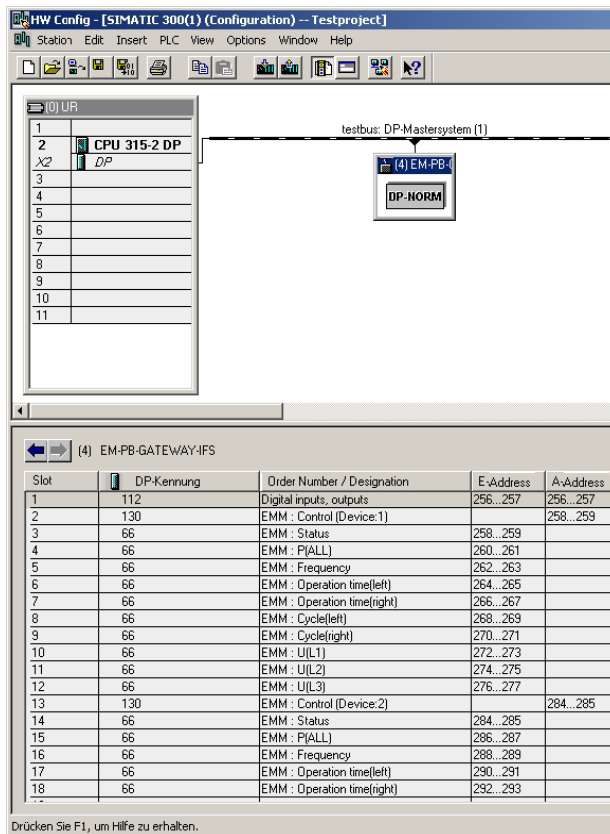

Figure 18-28 Opening the context menu of the EM-PB-GATEWAY-IFS

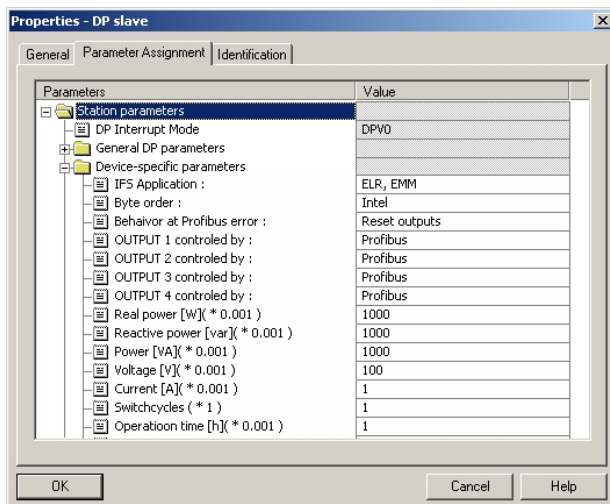
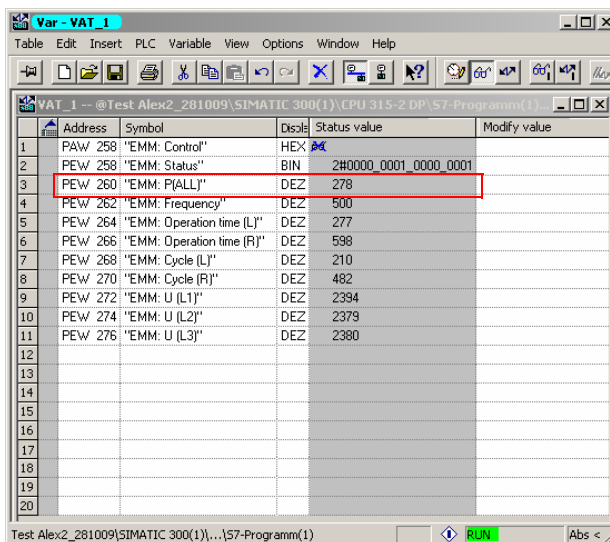

Figure 18-29 Object properties of the EM-PB-GATEWAY-IFS

## Integration in STEP 7 with PROFIBUS communication

In the object properties of the EM-PB-GATEWAY-IFS, the conversion factors for the measured values can be specified.



Address	Symbol	Data type	Status value	Modify value
1 PAW 258	"EMM: Control"	HEX	8d	
2 PEW 258	"EMM: Status"	BIN	2#0000_0001_0000_0001	
3 PEW 260	"EMM: P(ALL)"	DEZ	278	
4 PEW 262	"EMM: Frequency"	DEZ	500	
5 PEW 264	"EMM: Operation time (L)"	DEZ	277	
6 PEW 266	"EMM: Operation time (R)"	DEZ	598	
7 PEW 268	"EMM: Cycle (L)"	DEZ	210	
8 PEW 270	"EMM: Cycle (R)"	DEZ	482	
9 PEW 272	"EMM: U (L1)"	DEZ	2394	
10 PEW 274	"EMM: U (L2)"	DEZ	2379	
11 PEW 276	"EMM: U (L3)"	DEZ	2380	
12				
13				
14				
15				
16				
17				
18				
19				
20				

Figure 18-30 Variable overview

In the variable overview, individual values can be displayed.

In the example screen, you can see that the real power (ALL) is 278 W.



For each EM-PB-GATEWAY-IFS, a maximum of 32 words can be transferred during the cycle (66 ms).

## CONTACTRON motor management

---

## 19 Integration in CoDeSys with Modbus/TCP communication

This section describes the integration of the EM-MODBUS-GATEWAY-IFS in the CoDeSys programming environment using the CoDeSys Control RTE V3 software PLC from 3S-Smart Software Solutions. The Modbus/TCP master included in the CoDeSys 3.5 Patch 4 is used as the master. It is assumed that the user has knowledge of using the CoDeSys programming environment. For the installation of the required software, please refer to the manufacturer's website [www.codesys.com](http://www.codesys.com).

### 19.1 Flow chart

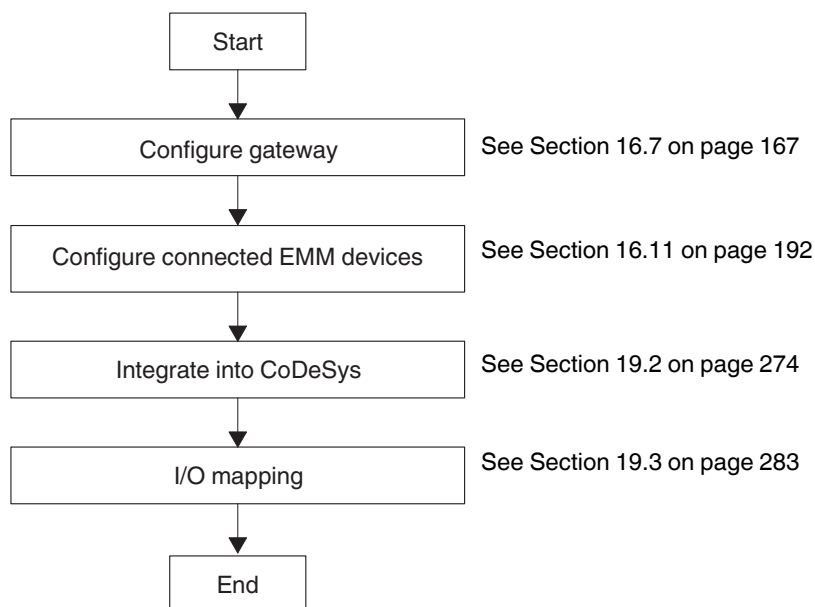

Figure 19-1 Flow chart

## 19.2 Integration in CoDeSys

1. Start CoDeSys.



Figure 19-2 CoDeSys icon

2. Create a new project.

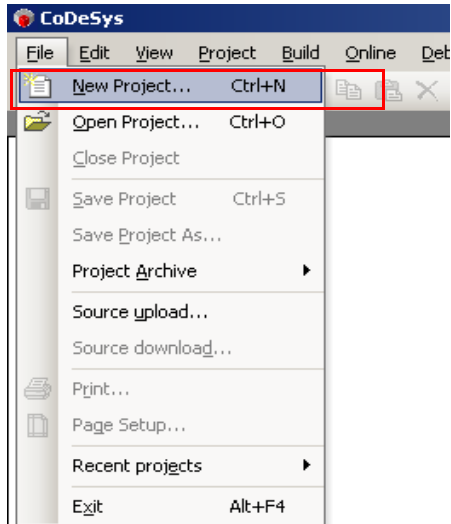

Figure 19-3 Creating a new project

## Integration in CoDeSys with Modbus/TCP communication

3. Select “Standardproject”, assign a project name, and define a storage location for the project.

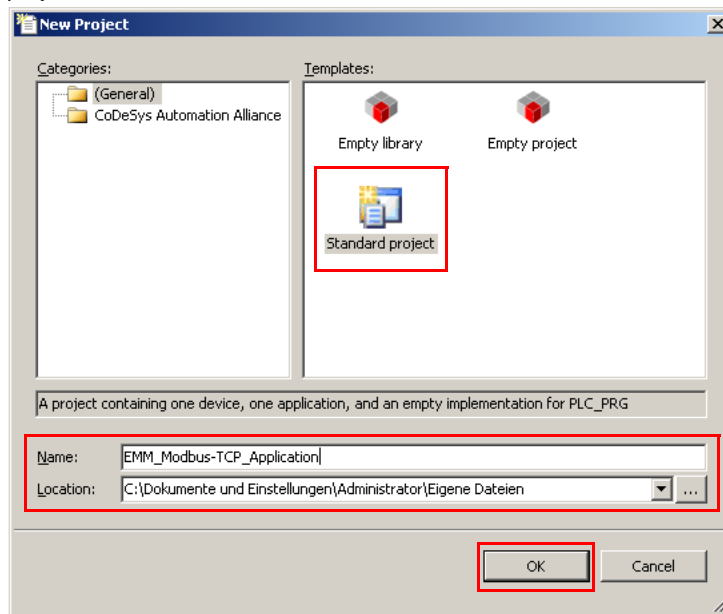

Figure 19-4 “New Project” dialog box

4. Confirm your selection with “OK”.
5. Select the soft PLC to be used (“CoDeSys Control RTE V3”) and the preferred programming language (here: Structured Text (ST)).

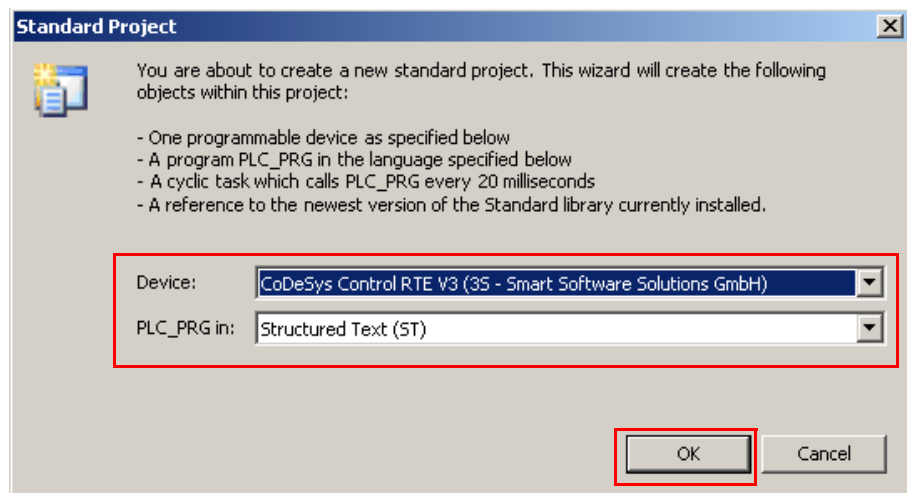

Figure 19-5 Selecting the controller and the preferred programming language

6. Confirm your selection with “OK”.

## CONTACTRON motor management

7. Make the communication settings for the soft PLC. Open the “Device” tab by double-clicking on “Device” in the “Device” window.

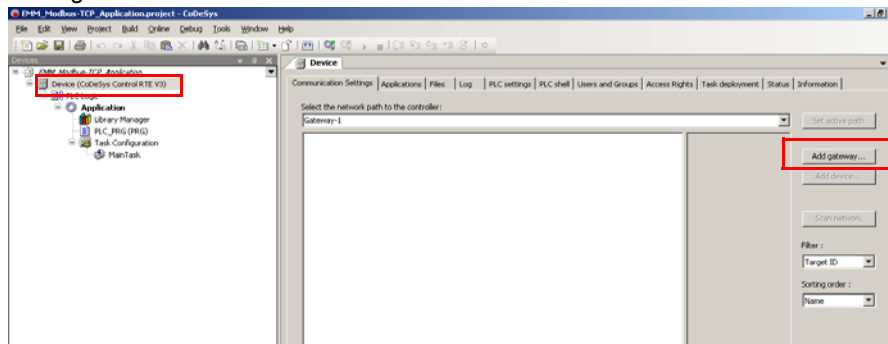

Figure 19-6 Communication settings

8. Clicking on the “Add gateway...” button opens a window. You can now enter a name for the gateway. The other settings are accepted.

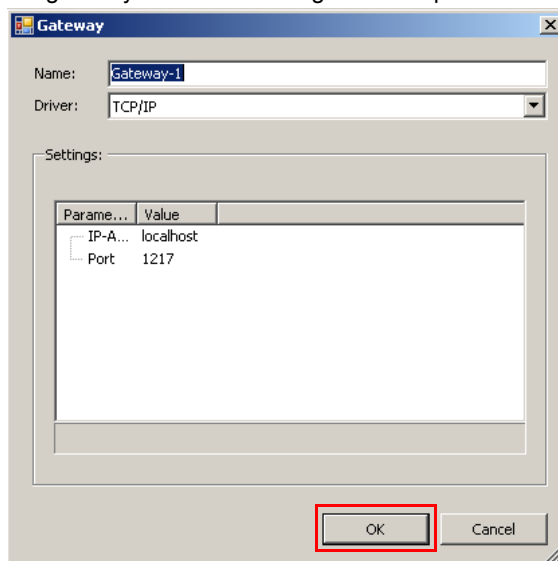

Figure 19-7 Adding a gateway

9. Confirm your selection with “OK”.

## Integration in CoDeSys with Modbus/TCP communication

10. Click on the “Scan network” button.

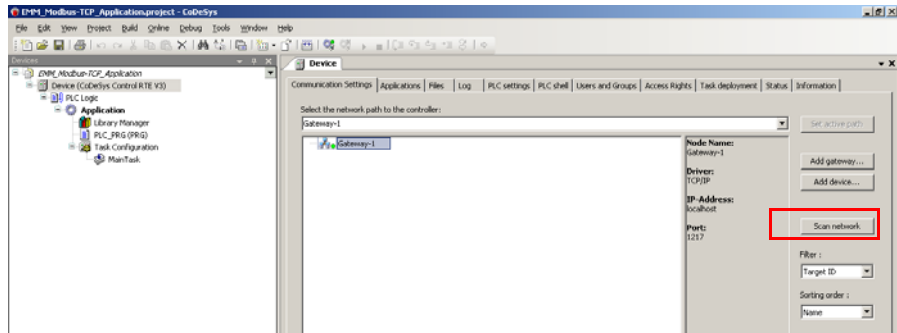

Figure 19-8 Scanning the network

11. The controller found, i.e., “CoDeSys Control RTE V3”, has the name of the PC used. Select the controller by clicking on the “Set active path” button.

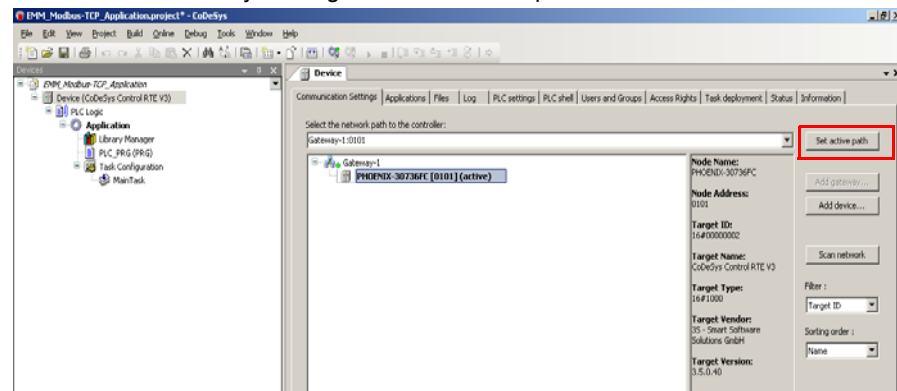

Figure 19-9 Setting the active path

## CONTACTRON motor management

12. Add a Modbus/TCP master to the controller by right-clicking on “Device (CoDeSys Control RTE V3)” and then selecting the “Add Device...” menu item.

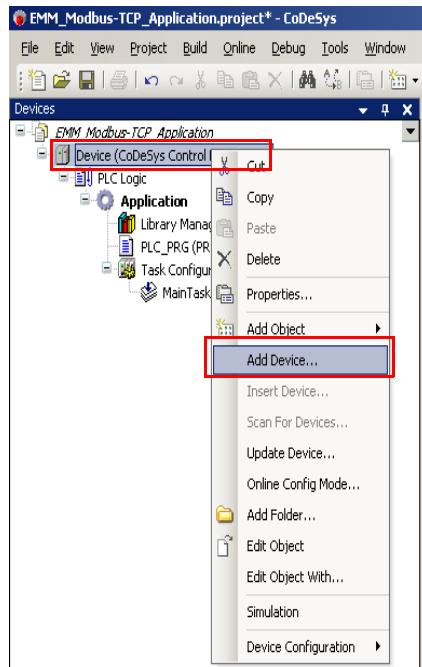

Figure 19-10 Adding a device

## Integration in CoDeSys with Modbus/TCP communication

13. In the dialog box that opens, select the adapter provided by 3S under the “Ethernet Adapter” item and click on “Add Device”.

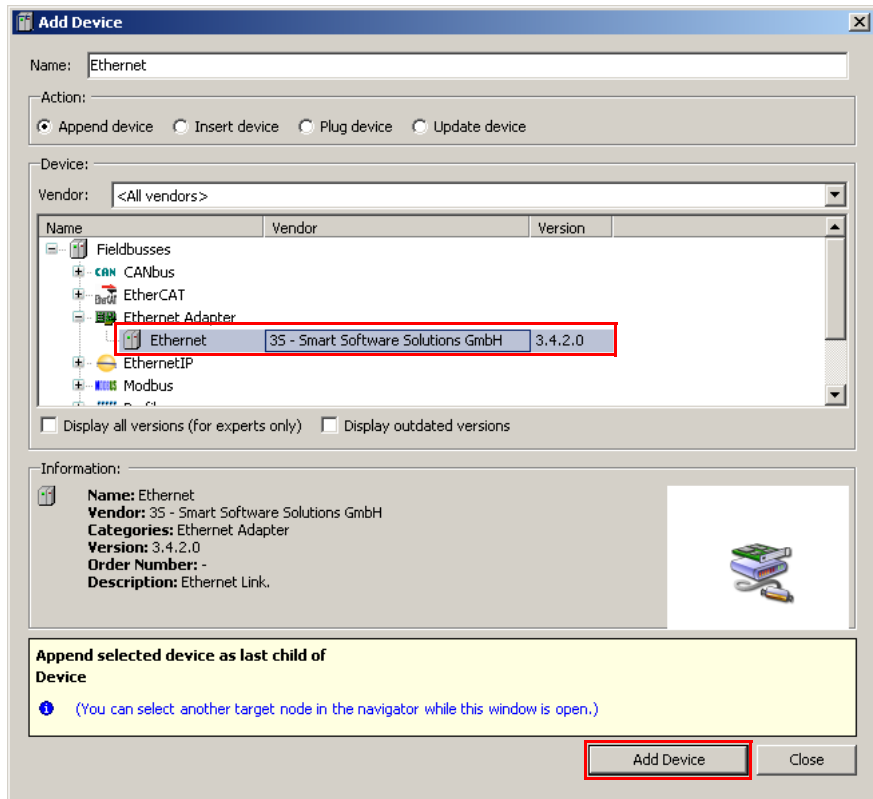

Figure 19-11 Add Device dialog box – Ethernet adapter

## CONTACTRON motor management

14. Add the 3S Modbus/TCP master to the Ethernet adapter now connected as described in steps 12 and 13.

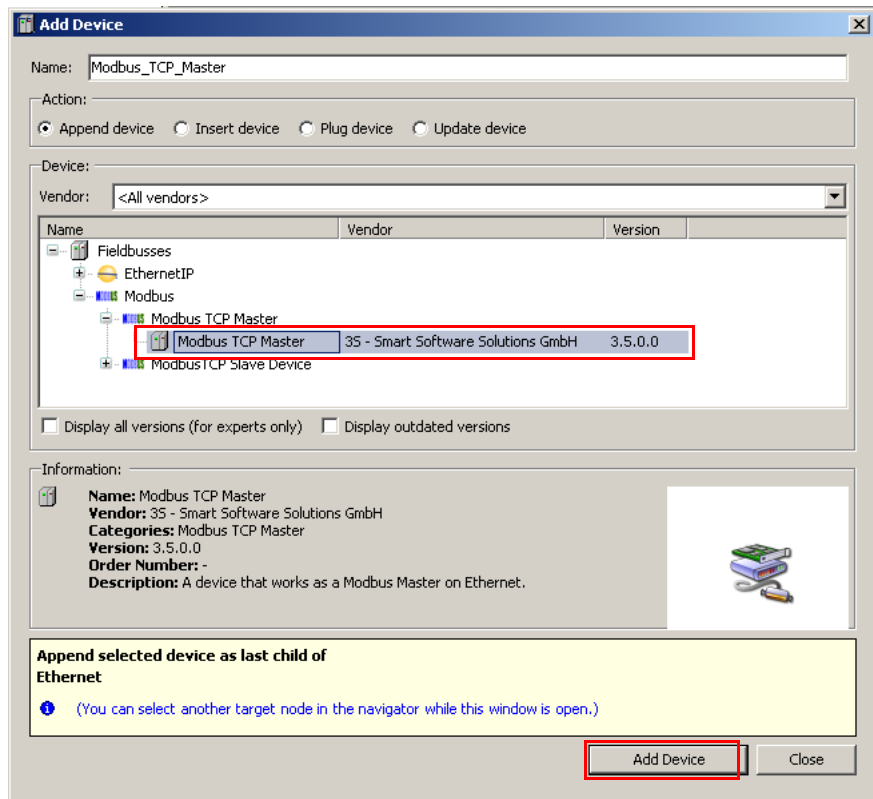

Figure 19-12 Add Device dialog box - Modbus/TCP master

## Integration in CoDeSys with Modbus/TCP communication

15. Now add a Modbus/TCP slave device to this master in the same way.

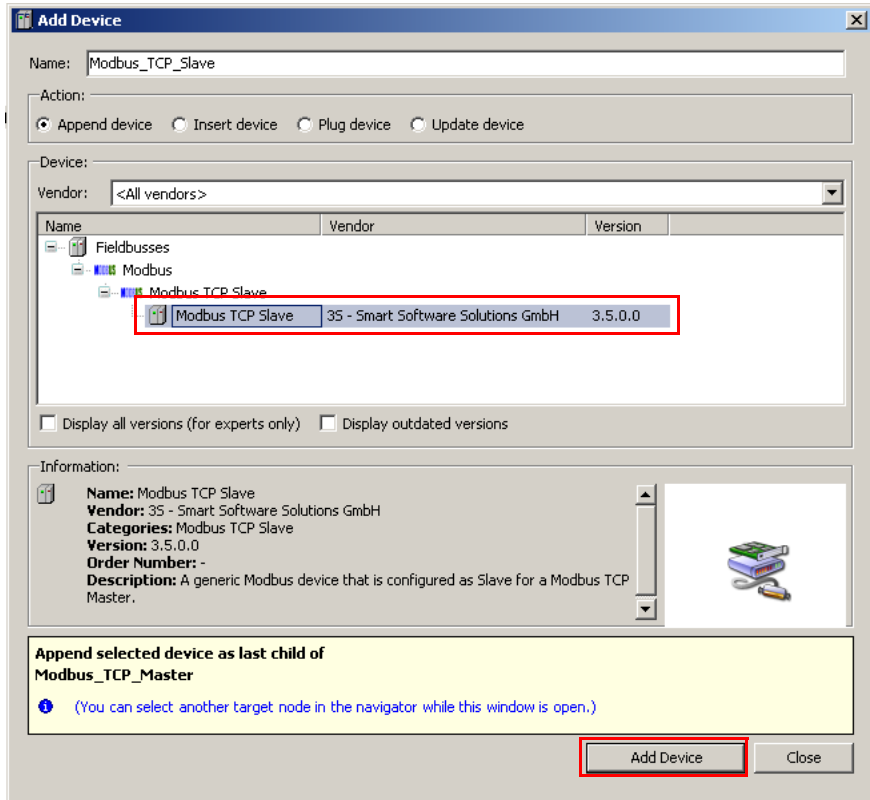

Figure 19-13 Add Device dialog box - Modbus slave

## CONTACTRON motor management

16. This device is the EM-MODBUS-GATEWAY-IFS and the connected EMM motor manager. You can change the device name by right-clicking on the slave and then selecting “Properties”.

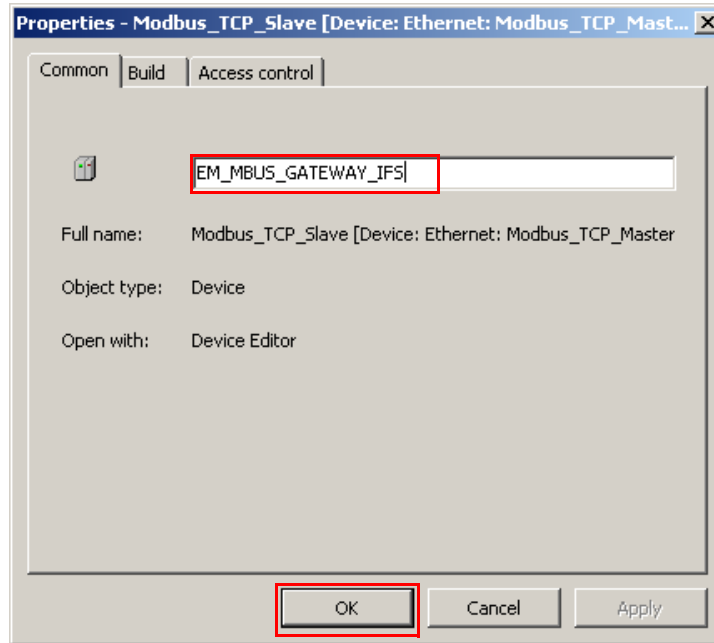

Figure 19-14 Properties of the Modbus/TCP slave

17. Confirm your selection with “OK”.
18. Double-clicking on the Modbus/TCP slave opens the editor in which you can enter the IP address set in the gateway (see Section “Settings” on page 167) directly on the first tab. In addition, unit ID 128 which is preset in the gateway must be entered.

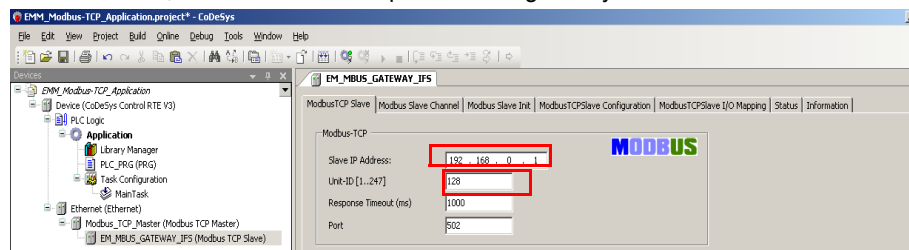

Figure 19-15 Modbus/TCP slave settings

The EM-MODBUS-GATEWAY-IFS has now been integrated completely in the CoDeSys environment and the communication settings have been made. In the next step, the settings for processing the process data provided in the IFS gateway (see Section “Process data configuration” on page 163) can be made.

## 19.3 I/O mapping

1. Switch to the “Modbus Slave Channel” tab in the Modbus slave editor. Click on “Add Channel...” and define the inputs and outputs according to the Modbus/TCP protocol.

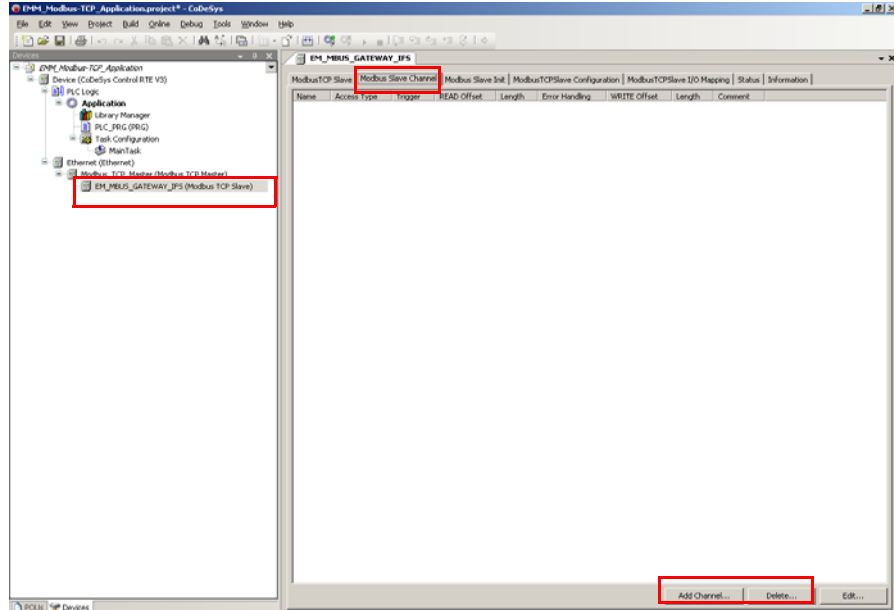

Figure 19-16 Modbus slave channel

## CONTACTRON motor management

- Now, set the inputs defined in the process data configuration (see Section “Process data configuration” on page 163) as “Read Input Registers (Function Code 04)”. For the EM-MODBUS-GATEWAY-IFS, they begin with address 0x7440 in hexadecimal format. The length corresponds to the number of data set in the process data configuration.

The screenshot shows the 'ModbusChannel' configuration dialog box. The 'Channel' section is configured with Name: Inputs, Access Type: Read Input Registers (Function Code 04), Trigger: Cyclic, and Cycle Time (ms): 100. The 'READ Register' section is configured with Offset: 0x7440, Length: 1, and Error Handling: Keep last Value. The 'WRITE Register' section has an empty Offset field and Length: 1. The 'OK' button is highlighted with a red box.

Figure 19-17 Modbus channel - Inputs

- Confirm your selection with “OK”.

## Integration in CoDeSys with Modbus/TCP communication

- Define the outputs as “Write Multiple Registers (Function Code 16)”. They begin with address 0x74E1 (hexadecimal). The length again depends on the number of defined data (see Section “Process data configuration” on page 163).

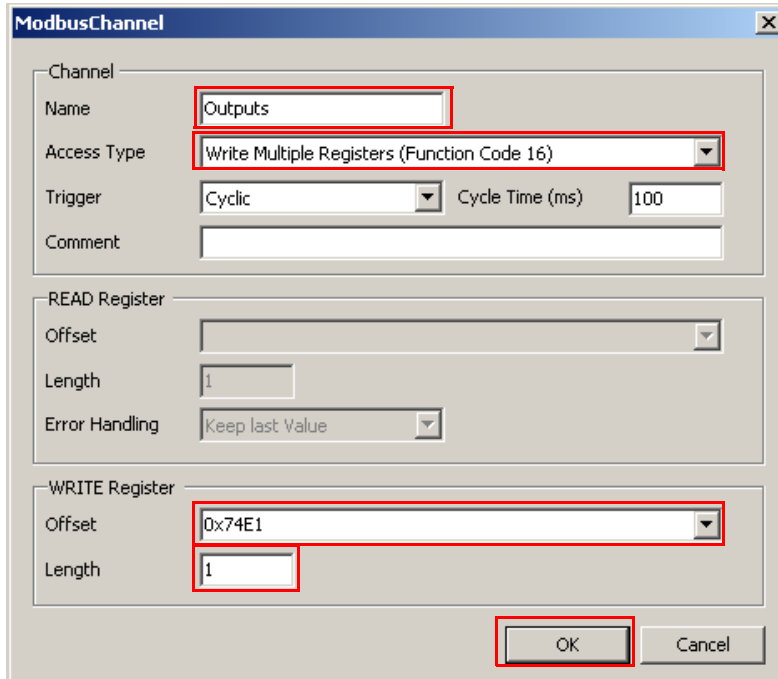

Figure 19-18 Modbus channel - Outputs

- Confirm your selection with “OK”.
- Assign variables to the process data which can be used in a corresponding program. To do so, access the “ModbusTCP Slave I/O Mapping” tab.

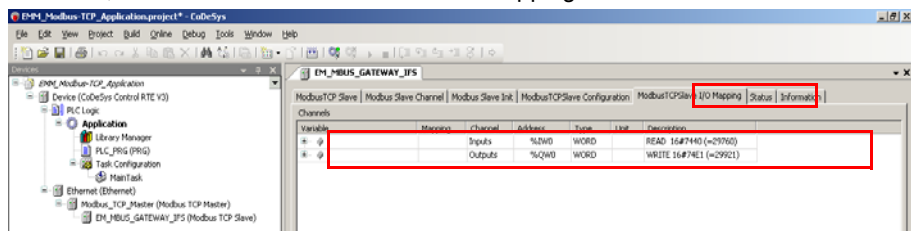

Figure 19-19 Variables assignment

After you have assigned variables to the process data, you can write a program for controlling and monitoring the connected motor managers.

## 19.4 Example

In the following application example, an EMM motor manager connected to an EM-MODBUS-GATEWAY-IFS is to be controlled via the CoDeSys Control RTE V3 soft PLC as a reversing starter. In addition, the total real power is to be read permanently.

The settings for the gateway and the motor manager have been made in the DTM software (see Section “Settings” on page 167 and Section “EMM 3- xx/500AC/xx-IFS module DTM” on page 192). The settings of the previous sections for integrating the device in the CoDeSys programming environment up to creating the variable map (Section “Integration in CoDeSys” on page 274) have also been completed.

1. Assign the “EMM1\_P\_ALL” variable to the input value and the “EMM1\_ControlWord” variable to the output value.

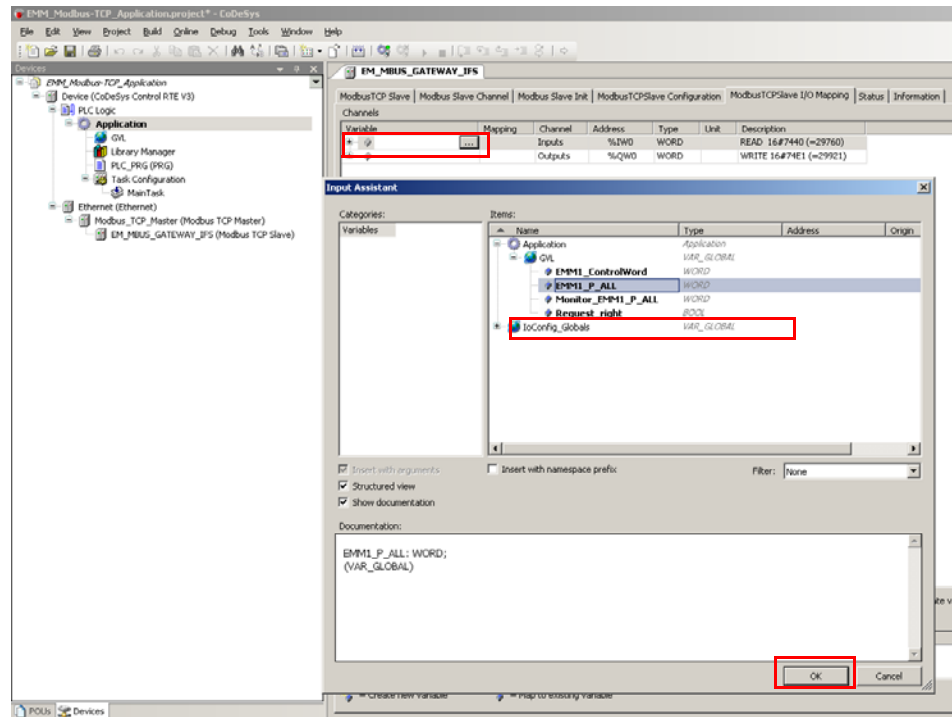

Figure 19-20 Assigning the input and output words

2. Confirm your selection with “OK”.

## Integration in CoDeSys with Modbus/TCP communication

- Double-click on the PLC\_PRG (PRG) in the “Device” tree to open the programming window. The program can now be written in the bottom area:

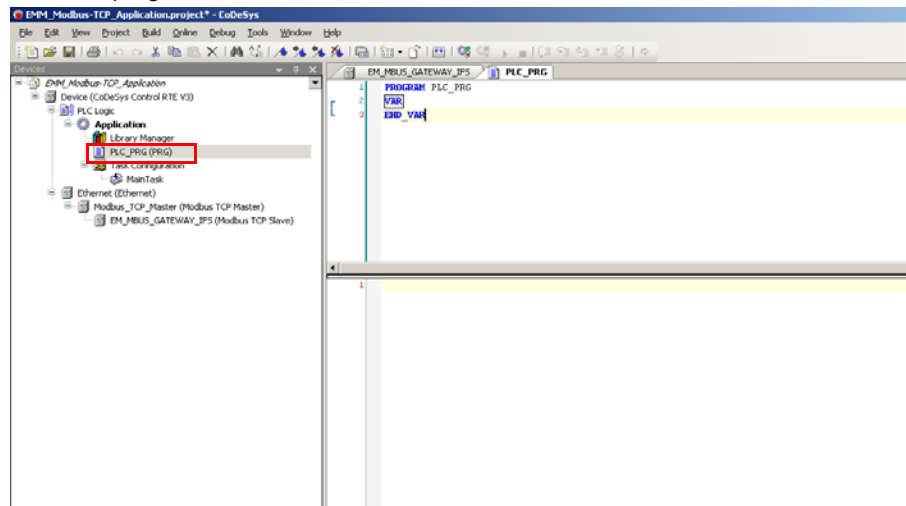

Figure 19-21 PLC\_PRG block

The completed program in ST is shown in the following figure. Depending on the requirements (right or left rotation), assign value 0 or 2 (decimal) to the “EMM1\_ControlWord” variable, which is the same hexadecimal value in this case (see Section “EMM objects” on page 44).

Assign the value of the “EMM1\_P\_ALL” variable additionally to the “Monitor\_EMM1\_P\_ALL” variable; it is used to permanently read the real power of the first EMM in the I/O map.

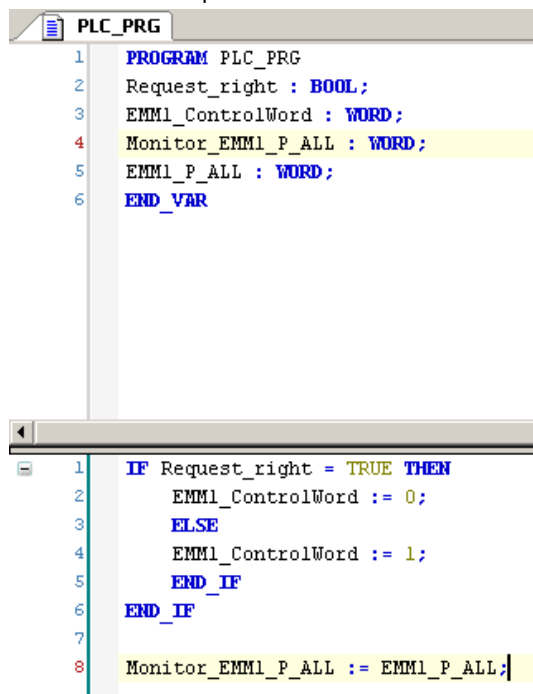

Figure 19-22 Example program in ST

## CONTACTRON motor management

---

4. Transfer the created program to the controller by clicking on the “Translation” shortcut.
5. Run the created program on the controller by clicking on the “Log in” shortcut.

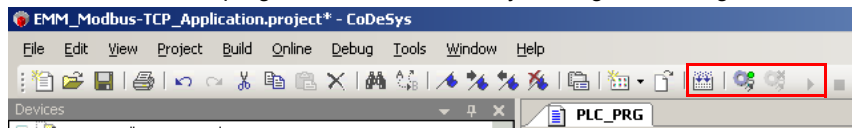

Figure 19-23 Translating the application and downloading it to the controller

## 20 Integration in a CompactLogix controller from Allen-Bradley

This section describes how you integrate the EM-ETH-GATEWAY-IFS (Order No. 2901988) from Phoenix Contact into a CompactLogix controller from Allen-Bradley using the RSLogix 5000 or Studio 5000 software.

For example, in this case, CompactLogix 1769-L-18ERBB1B and software version V20.01.00 are used.

For the system requirements for operating RSLogix, please refer to the manufacturer's documentation.

### 20.1 Integrating the EDS file

To integrate the EM-ETH-GATEWAY-IFS (Order No. 2901988) into a CompactLogix controller from Allen-Bradley, you need an appropriate device description in EDS format. This "EM-ETH-GATEWAY-IFS.eds" device description can be downloaded at [phoenixcontact.net/products](http://phoenixcontact.net/products) in the product download area.

1. Install the device description of the EM-ETH-GATEWAY-IFS via RSLogix, by calling the installation program under "Tools, Hardware installation tool" or via "Start, Programs, Rockwell Software, RSLinx, Tools, EDS Hardware installation tool".

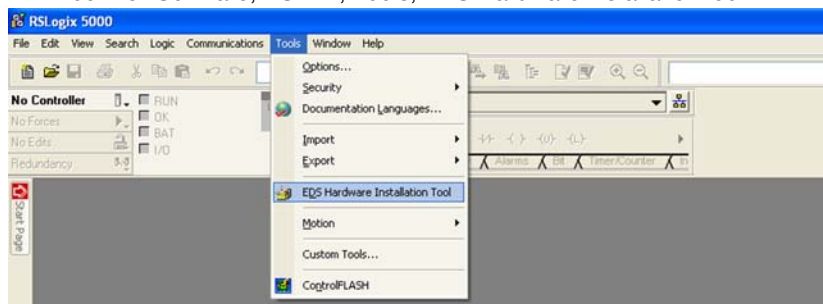

Figure 20-1 Hardware installation tool

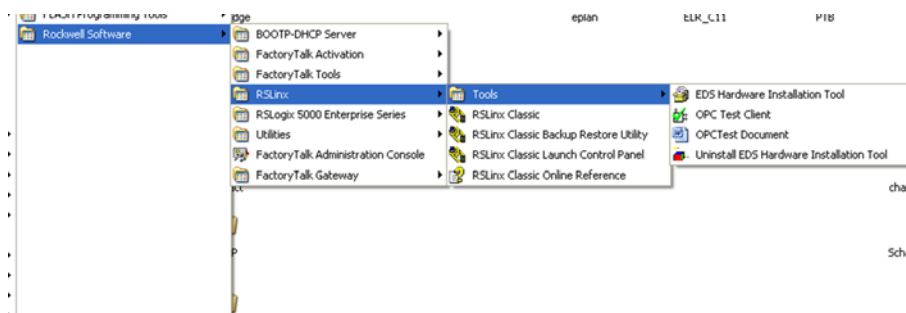

Figure 20-2 Hardware installation tool

2. Follow the other installation instructions.

## CONTACTRON motor management

## 20.2 Creating a project

1. Create a new project by clicking “File, New”.

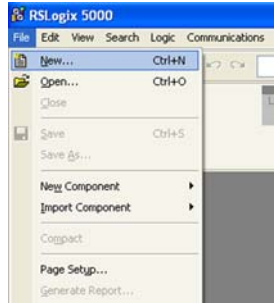

Figure 20-3 Creating a project

2. Select your controller.

In this example, a CompactLogix 1796-L18ER-BB1B is used.

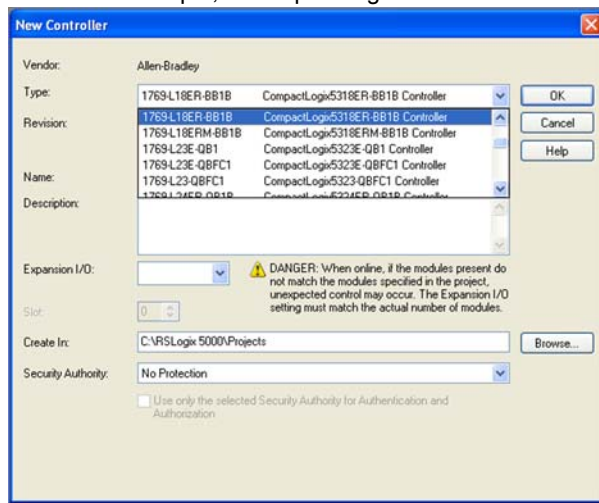

Figure 20-4 Selecting the controller

3. Set the controller according to your requirements.
4. Assign a project name (in the following “Controller 1”).
5. Specify a storage location.

For details on how to proceed, please refer to the relevant user documentation of the manufacturer.

## 20.3 Integrating the EM-ETH-GATEWAY-IFS

1. In the project tree, click in the “Controller Organizer” window and right-click on “Ethernet, New Module”.

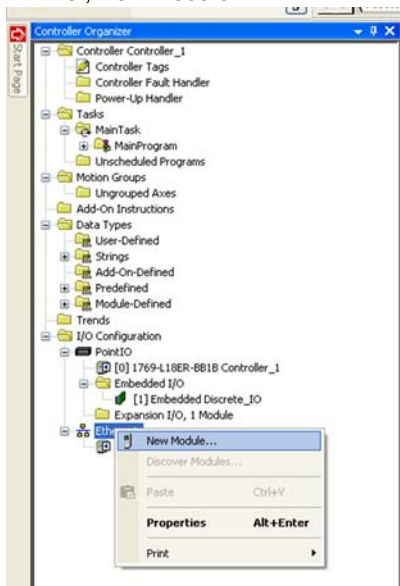

Figure 20-5 Integrating the new module

The “Select Module Type” dialog box opens.

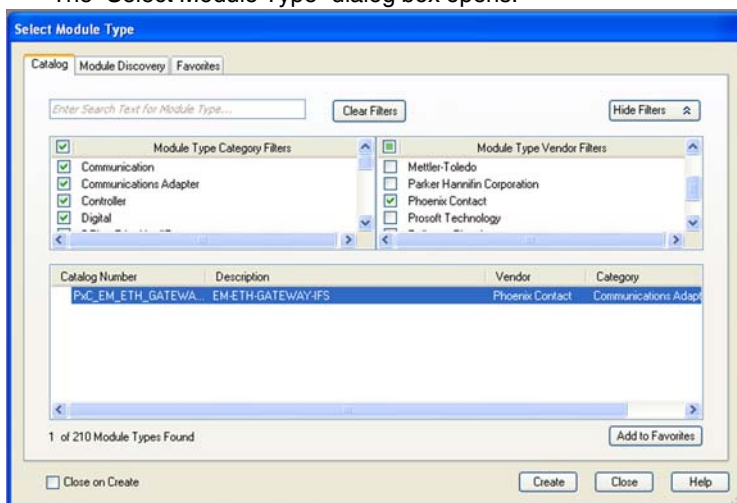

Figure 20-6 Selecting a module type

2. Activate the “Module Type Vendor Filter”.
3. Select “Phoenix Contact”.

## CONTACTRON motor management

4. Activate the “EM-ETH-GATEWAY-IFS” device description by double clicking it.

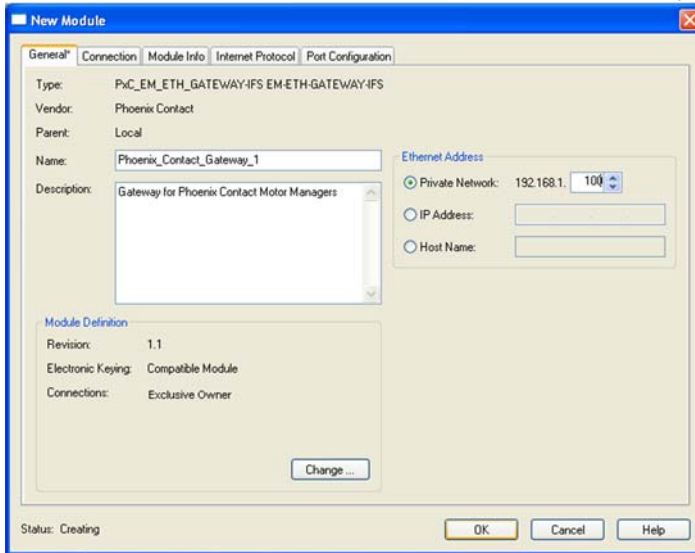

Figure 20-7 Describing the module

5. Give the device a name (for example, “Phoenix\_Contact\_Gateway\_1”).
6. Assign an IP address to the device.
7. Click the “Change” button.

The “Module Definition” window opens.

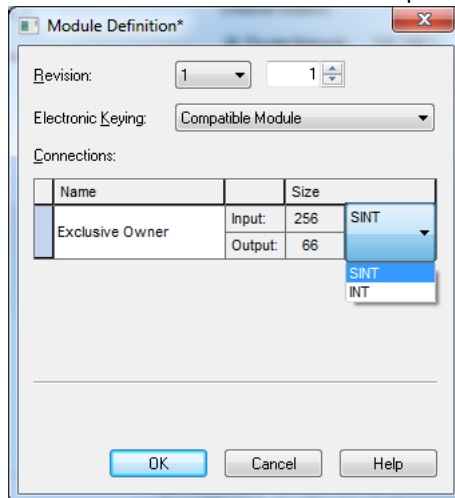

Figure 20-8 Module definition

8. Change the data type from “SINT” to “INT”.
9. Confirm the change with “OK”.



The IP configuration is downloaded to the device via the FDT/DTM software IFS-Conf. For the procedure, please refer to Section “Software configuration” on page 156.

Integration in a CompactLogix controller from Allen-Bradley

You will then find the device in the project tree.

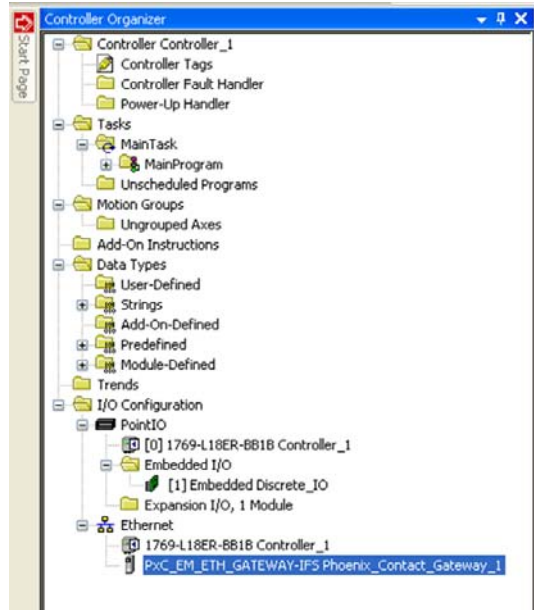

Figure 20-9 Device in the project tree

The list of transmitted process data can be found under “Controller Tags”.

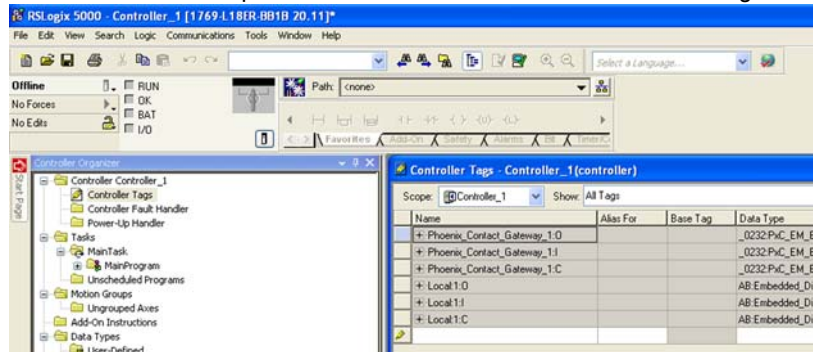

Figure 20-10 Transmittable process data

## CONTACTRON motor management

---

## 21 EM-MODBUS-GATEWAY-IFS used with the Phoenix Contact controllers

This section describes the implementation and startup of the EM-MODBUS-GATEWAY-IFS on the Phoenix Contact controllers, using a project creation with PC Worx as an example.

### 21.1 System requirements

#### 21.1.1 Software requirements

To use Modbus/TCP, work with the AUTOMATIONWORX Software Suite Version 1.70 Service Pack 1 or later and the IFS-CONF SUITE-INTERFACE.

#### 21.1.2 Hardware requirements for PC Worx

For the hardware requirements, please refer to the UM QS EN PC WORX quick start guide for PC Worx.

### 21.2 Modbus/TCP

Modbus is a communication protocol used to exchange process data between a client and a server in an Ethernet network. There are three different operating modes for data transmission: Modbus ASCII, Modbus/RTU and Modbus/TCP.

In Modbus/TCP mode, the TCP protocol (Transmission Control Protocol) is used for data transmission. The Modbus protocol data to be transmitted is embedded in the TCP protocol. A TCP/IP connection must be established between the client and the server prior to data transmission. In general, the connection is established automatically. The established TCP/IP connection between client and server remains permanently active during cyclic communication. For acyclic communication, however, the TCP/IP connection can be disconnected once the data has been transmitted and then reestablished if there is a communication request. By default, the TCP port 502 reserved for Modbus is used for communication.

The client initiates communication between the client and the server. The client sends a request in the form of a command code (and data, if required) to the server. After successful receipt of the request, the server sends a corresponding response to the client which includes the requested data and status information or an error message. The data may contain bit or word information.

The device-internal data organization (memory addresses, etc.) varies depending on the device and manufacturer. Please refer to the documentation of the corresponding device for more information.

Modbus provides various commands for read and write access to digital inputs and outputs and to registers for client/server communication.

## CONTACTRON motor management

The following table shows the supported Modbus function codes:

Modbus function codes			
Code No.	Function code	Description	Method
FC1	Read Coils	Read several internal bits or digital outputs	Bit-by-bit/word-by-word
FC2	Read Discrete Inputs	Read several digital inputs	Bit-by-bit/word-by-word
FC3	Read Holding Register	Read several internal registers or output registers	Word-by-word
FC4	Read Input Register	Read several input registers	Word-by-word
FC15	Write Multiple Coils	Write several internal bits or digital outputs	Bit-by-bit/word-by-word
FC16	Write Multiple Register	Write several internal registers or output registers	Word-by-word
FC23	Read/Write Multiple Registers	Read and write several internal registers or output registers simultaneously	Word-by-word

### 21.3 Example of a project with Modbus

This project consists of the ILC 171 ETH (controller) and the EM-MODBUS-GATEWAY-IFS.

#### 21.3.1 Sequence for creating the Modbus project

The complete sequence for creating the Modbus project in PC Worx is shown in Figure 21-1.



For more detailed information on creating a project, please refer to the UM QS EN PC WORX quick start guide or the PC Worx online help.

When implementing the project, most of the tasks are performed offline (without a connection to the Modbus system).

## EM-MODBUS-GATEWAY-IFS used with the Phoenix Contact controllers

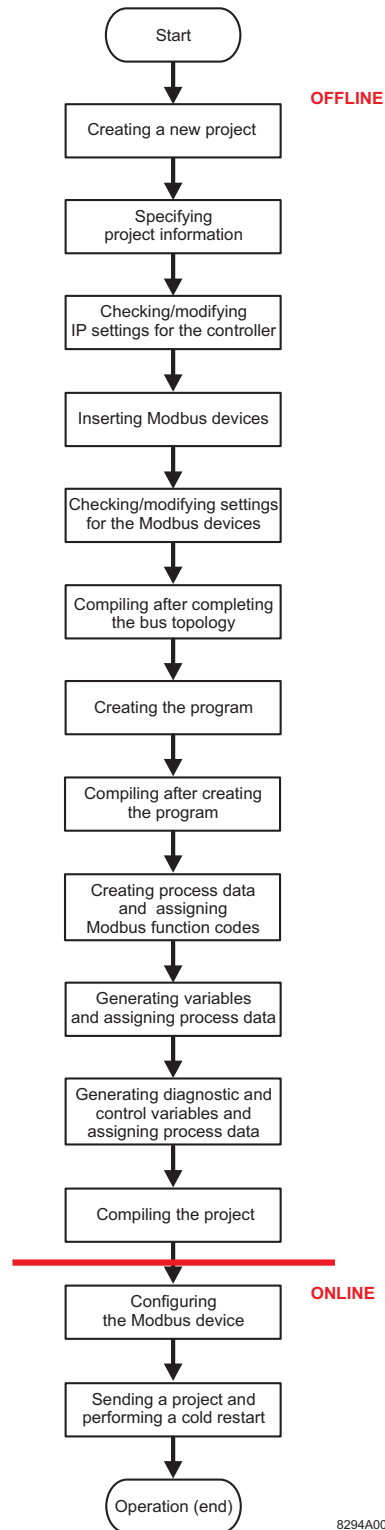

Figure 21-1 Sequence for creating the Modbus project



The sequence described here for creating a Modbus project applies to projects based on cyclic communication between the controller and the Modbus device.

Section “Acyclic communication using the MB\_ASYNC\_RW function block” on page 305 provides general information on acyclic communication.

### **21.3.2 Creating a new project**

1. Select the “New Project...” command from the “File” menu.
2. Select the controller and confirm with “OK”.
3. Select the “File, Save Project As / Zip Project As...” command.
4. Enter a unique and meaningful project name and save the project.

### **21.3.3 Specifying project information**

1. Switch to the bus configuration workspace.
2. Adapt the project information to your project.

### **21.3.4 Checking/modifying IP settings for the controller**

The IP settings for the controller are made when the project is created.

1. Adapt these settings, if necessary.
2. Switch to the bus configuration workspace.
3. Select the controller node.
4. In the “Device Details” window, switch to the “IP Settings” tab.
5. Check the IP settings and modify them, if necessary.
6. Assign an IP address, if it has not yet been assigned. For detailed information on assigning the IP address, please refer to the UM QS EN PC WORX quick start guide.



The IP address that is assigned here for the controller is also implemented as the IP address for the communication path via TCP/IP.

### 21.3.5 Inserting a Modbus device

1. Make sure you are in the bus configuration workspace.
2. Insert the module as a generic Modbus device below the MODBUS\_CLT node.
3. If the device catalog is hidden, show it by selecting the “View, Device Catalog” menu.
4. Open the “Phoenix Contact, Generic, Device” device catalog.
5. Select the “Generic Modbus Device”.

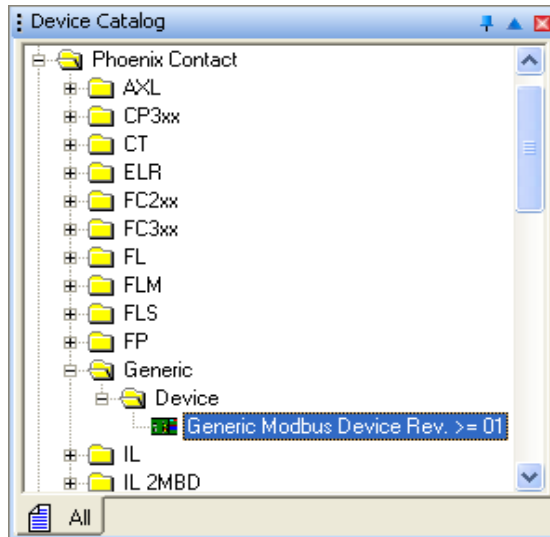

Figure 21-2 Selecting the Modbus device

6. Hold down the left mouse button and move the Modbus device to the “Bus Structure” window to the right of the MODBUS\_CLT icon until the “Insert in the lower level” icon appears.
7. Move all other Modbus devices to below the preceding Modbus device until the “Insert at the same level” icon appears.

Figure 21-3 shows the bus configuration with the inserted Modbus device.

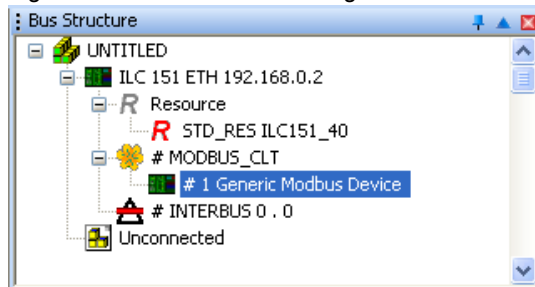

Figure 21-3 Generic Modbus device inserted



The “Blind out device” or “Deactivate Bus” option can be selected via the context menu of the device.

To make the device visible again or to activate the bus, re-select the above-mentioned settings from the context menu.

### 21.3.6 Modifying the settings for the Modbus device

After having added devices to the bus configuration, default values are set for each Modbus device. The settings can be modified via the “Modbus-Settings” tab.

1. Make sure you are in the bus configuration workspace.
2. In the “Bus Structure” window, select the Generic Modbus Device.
3. Under “Device Details”, select the “Modbus-Settings” tab.
4. Modify the Modbus settings depending on your requirements.

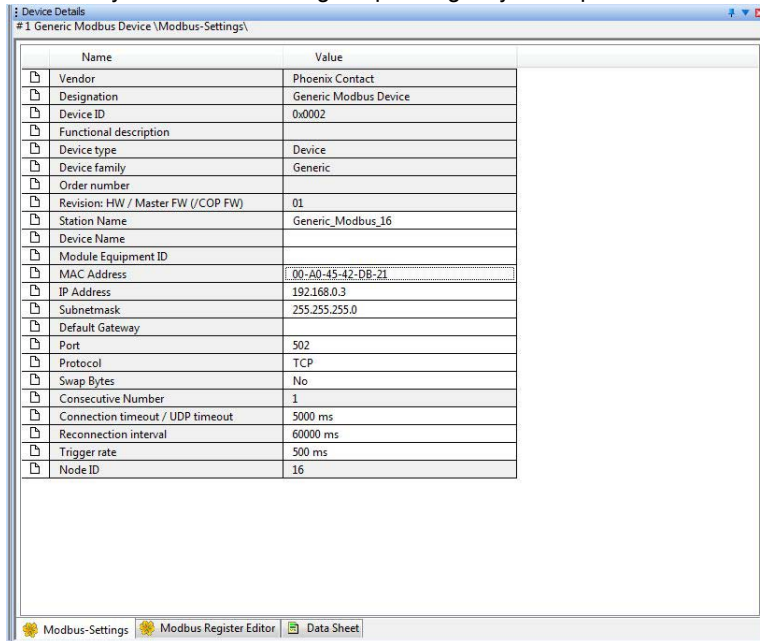

Figure 21-4 Modbus settings of the EM-MODBUS-GATEWAY-IFS device

The Modbus settings comprise:

#### Station name

This name is the unique identification for the Modbus device in the network. It must be known to the Modbus device before it can be used in the network.

#### MAC address

The MAC address is used to provide worldwide unique identification for each network device.

Enter the MAC address of the Modbus device. It is printed on the respective device. It starts with “00.a0.45.” on Phoenix Contact devices.

#### IP address

The IP address allows the Modbus device to be accessed during operation. PC Worx selects the address out of the area that is set on the project node.



If the area for the IP addresses is later modified in the project node, you will also have to adapt the addresses of the Modbus device accordingly.

---

## EM-MODBUS-GATEWAY-IFS used with the Phoenix Contact controllers

---

### Subnet mask

The subnet mask that was specified on the project node is assigned to each Modbus device. It can be modified specifically for each individual device.

### Connection timeout

This value specifies the minimum time required to identify an interruption.

### Reconnection interval

When the connection is interrupted (connection timeout) and the set time interval elapsed, an attempt is made to establish a new connection.

### Trigger rate

The trigger rate specifies the time period during which data is exchanged with the server. The smallest trigger rate of all configured Modbus devices determines the bus cycle time.

## 21.3.7 Compiling after completing the bus topology

1. Select the “Build, Make” command.

## 21.3.8 Creating the program

1. Create the program.

To program the example program, proceed as described in the UM QS EN PC WORX quick start guide.

## 21.3.9 Compiling after creating the program

1. Select the “Build, Make” command.

## 21.3.10 Creating process data and assigning Modbus function codes

1. Define specific process data for read and write access to digital inputs and outputs as well as to registers and assign the data the corresponding Modbus function code.
2. Make sure you are in the bus configuration workspace.
3. In the “Bus Structure” window, select the Generic Modbus Device.
4. Under “Device Details”, select the “Modbus Register Editor” tab.
5. Specify a unique and meaningful name for the process data item in the “Name” field.
6. Select the desired “Function Code”, see Table “Modbus function codes” on page 296.
7. Use function code FC03 for reading 16-bit words and function code FC15 for writing.
8. Select the desired data type.
9. Enter the number of bits or registers to be read or written.
10. For the Modbus device, enter the memory area of the process data item as the “Address” for which the selected function code should be used.

## CONTACTRON motor management

The memory area corresponds to the address that was assigned in the process data configuration using the IFS-Conf software (see “Process data configuration” on page 163).

In the example, a 16-bit word should be read from an internal register. The FC03 Modbus function code is used for this. Value “29760” is set as the address, since the memory area for the process data item used to read an internal register word-by-word has the value “29760” for the EM-MODBUS-GATEWAY-IFS.

- The “Data Direction” indicates whether the function accesses a digital input/an internal register or a digital output/output register. The data direction depends on the selected function code and cannot be modified manually.

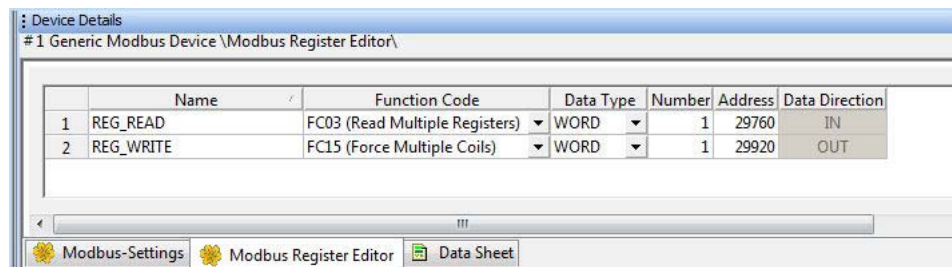

Figure 21-5 Creating process data and assigning Modbus function codes

### 21.3.11 Generating variables and assigning process data

Process data and variables are assigned in the process data assignment workspace.

- Switch to the process data assignment workspace to assign the variables to the process data.
- Select the Modbus device in the top right window. The standard configuration is then displayed in the top left window, “Symbols/Variables”.
- In the top left window, “Symbols/Variables”, select the standard resource.
- In the top right window, select the device for which you would like to link the process data to variables (in Figure 21-6: Generic Modbus Device; in the example the EM-MODBUS-GATEWAY-IFS is used).
- Select the process data item to be linked.
- Variables are created when the program is created. Using drag and drop, link the selected variable to one of the displayed variables on the left-hand side.

If you would like to link further process data but no corresponding variables have been created yet, select “Create Variable” in the context menu.

The created variable is displayed in the bottom left window.

- Repeat this procedure for all inputs to be evaluated and for all outputs to be controlled.



Figure 21-6 All process data used are assigned to the variables

## EM-MODBUS-GATEWAY-IFS used with the Phoenix Contact controllers

### 21.3.12 Generating diagnostic and control variables and assigning process data



In the IEC programming workspace, the diagnostic and control structure is declared in the project tree window under “Data Types, sys\_flag\_types”.

IPC Worx provides a diagnostic and control structure for each Modbus device allowing the connection status, connection statistics and connection interruptions to be read. To use the diagnostic and control structure, create a diagnostic variable and a control variable.

1. Switch to the IEC programming workspace.
2. In the project tree window, double-click on “Global Variables”.  
The global variables of the standard resource are displayed.
3. Enter a new variable via the context menu which should be used as the control variable.
4. Select the MBT\_STATION\_CONTROL type for the control variable.
5. Enter a new variable via the context menu which should be used as the diagnostic variable.
6. Select the MBT\_STATION\_DIAG type for the diagnostic variable.

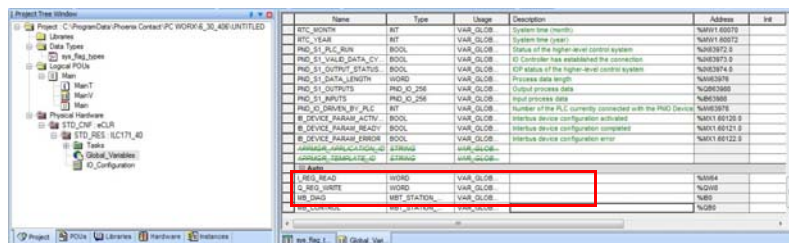

Figure 21-7 Generating diagnostic and control variables

7. Switch to the process data assignment workspace to assign the process data to the control and diagnostic variables, as described in Section 21.3.11 on page 302.

The result of process data assignment is shown in Figure 21-8.

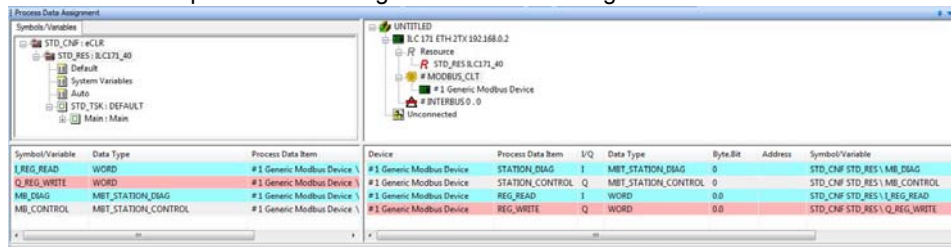

Figure 21-8 Process data assigned to the control and diagnostic variables

### 21.3.13 Compiling a project

1. Select the “Build, Make” command.

### 21.3.14 Configuring the Modbus device

Perform all of the required configurations for the Modbus device (e.g., setting the IP address and process data watchdog).

For information on how to configure and start up the device, please refer to Section 16 on page 151.

Make sure that the “PC Worx mode” configuration setting has been activated by the IFS-Conf software.



Bitstring of process data words:

The EM-MODBUS-GATEWAY-IFS saves the data words in Big Endian format (Motorola), i.e., the high-order byte is saved first. The ILC saves the data words in Little Endian format (Intel), i.e., the low byte is saved first.

Take this into account when controlling the outputs (here: RegWrite).

### 21.3.15 Sending a project and performing a cold restart

1. Open the “Project Control Dialog” dialog box.
2. Activate the “Include Bootproject” checkbox in the “Project” area.
3. Click on “Download” in the area on the left.

## 21.4 Acyclic communication using the MB\_ASYNC\_RW function block

The MB\_ASYNC\_RW function block enables acyclic communication between the controller and the Modbus device.

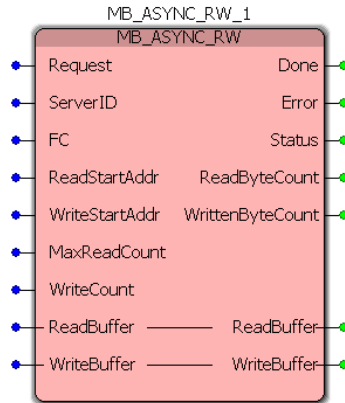





Figure 21-9 MB\_ASYNC\_RW function block

Input and output parameters of the function block		
Name	Data type	Description
Request	BOOL	The input parameters are checked and the function block is activated with a positive edge at this input.  After the function code has been executed successfully, the function block is deactivated and can only be re-activated by a new positive edge.
ServerID	BYTE	Server ID of the Modbus device in the bus configuration.  <div style="border: 1px solid black; padding: 5px;"> <p><b>Recommended:</b> Use the server ID of the previously created and linked diagnostic variable (see Section 21.4.2 “Using the server ID of the diagnostic variable”). Alternatively, the consecutive device number which is displayed in the “Device Details” window can be used (see Figure 21-4).</p> <p><b>Please note:</b> Under some circumstances, changes in the bus configuration may lead to modified consecutive device numbers. This may cause errors when creating the consecutive number as a server ID on the function block.</p> </div>
FC	BYTE	Modbus function code (see Table “Modbus function codes” on page 296)
ReadStartAddr	WORD	Start address of the memory as from which data should be read.
WriteStartAddr	WORD	Start address as from which data is to be written to the memory.
MaxReadCount	INT	Number of bits or registers to be read.
WriteCount	INT	Number of bits or registers to be written.



## CONTACTRON motor management

Input and output parameters of the function block		
Name	Data type	Description
Done	BOOL	TRUE: The function block has been executed successfully and acyclic communication has taken place. FALSE: The function block is still being executed or has not been executed.
Error	BOOL	True: An error has occurred. Details are provided by the "Status" output. FALSE: No error has occurred.  "Error" indicates an error as long as the "Request" input is active.
Status	DWORD	In the event of an error (Error = TRUE), the "Status" output contains an error code. The possible error codes are shown in Table 21.4.1 "Error codes of the "Status" output (Error = TRUE)".
ReadByteCount	INT	Number of read bits/registers
WrittenByteCount	INT	Number of written bits/registers
ReadBuffer	ARRAY OF BYTE, ARRAY OF WORD	Buffer (250 bytes, maximum) in which the read bits/registers are stored (depending on the function code used).  To define the size of the buffer, see Section 21.4.3 "Specifying the size of the ReadBuffer/WriteBuffer".
WriteBuffer	ARRAY OF BYTE, ARRAY OF WORD	Buffer (250 bytes, maximum) for the written bits/registers (depending on the function code used).  To define the size of the buffer, see Section 21.4.3 "Specifying the size of the ReadBuffer/WriteBuffer".

## 21.4.1 Error codes of the "Status" output (Error = TRUE)

Error codes of the "Status" output	
Value	Meaning
0x0101 0000	Unsupported/unknown Modbus function
0x0102 0000	The value for MaxReadCount is outside the permissible range.
0x0103 0000	The value for WriteCount is outside the permissible range.
0x0104 0000	Wrong data type for ReadBuffer. Permissible data types are ARRAY OF BYTE or ARRAY OF WORD.
0x0105 0000	The elements of the ReadBuffer array are not of the type WORD or BYTE.
0x0106 0000	Wrong data type for WriteBuffer. Permissible data types are ARRAY OF BYTE or ARRAY OF WORD.
0x0107 0000	The elements of the WriteBuffer array are not of the type WORD or BYTE.
0x0108 0000	ReadBuffer is too small. Reduce the number of elements for MaxReadCount or increase the ReadBuffer size.
0x0109 0000	WriteBuffer is too small. Reduce the number of elements for WriteCount or increase the WriteBuffer size.

## EM-MODBUS-GATEWAY-IFS used with the Phoenix Contact controllers

Error codes of the “Status” output	
Value	Meaning
0x010A 0000	ReadBuffer is too large.  To define the size of the buffer, see Section 21.4.3 “Specifying the size of the ReadBuffer/WriteBuffer”.
0x010B 0000	WriteBuffer is too large. .  To define the size of the buffer, see Section 21.4.3 “Specifying the size of the ReadBuffer/WriteBuffer”.
0x0201 0000	Unknown server ID (not configured)
0x0202 xxxx	Modbus protocol error code  For detailed information on the error codes of the Modbus/TCP protocol, please refer to the “MODBUS APPLICATION PROTOCOL SPECIFICATION” document.
0x0203 0016	Timeout when receiving the response from the Modbus device.
0x0203 0019	The connection was terminated by the Modbus device.
0x0203 001F	The request was not sent. The Modbus device is not accessible.
0x0301 0000	Timeout when receiving the response from the Modbus stack. The Modbus device is not accessible.

## 21.4.2 Using the server ID of the diagnostic variable



More detailed information on function block diagram (FBD) programming can be found in the UM QS EN PC WORX quick start guide.

1. Double-click on the “ServerID” input parameter of the function block to specify the variable properties.
2. In the “Variable Properties” window, select the name of the previously created diagnostic variable (here: “MB\_DIAG”).

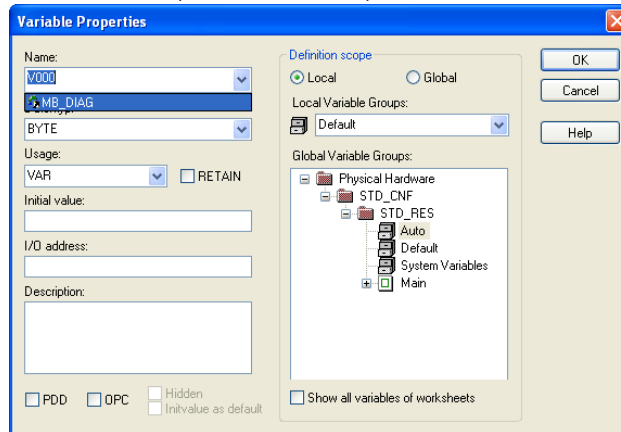

Figure 21-10 Creating the MB\_DIAG.ServerID variable (1)

3. Put a period after the selected name and select the “ServerID” entry from the appearing list.

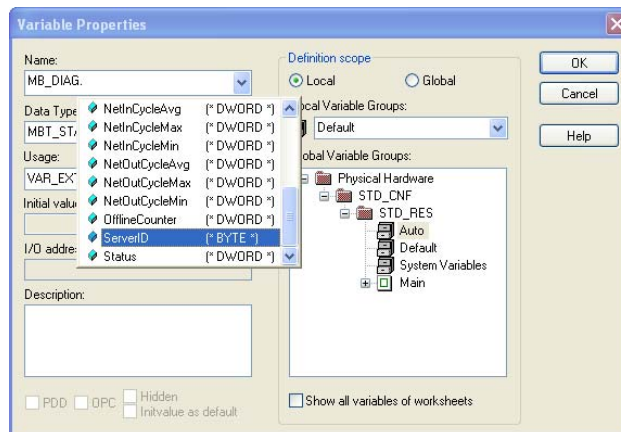

Figure 21-11 Creating the MB\_DIAG.ServerID variable (2)

EM-MODBUS-GATEWAY-IFS used with the Phoenix Contact controllers

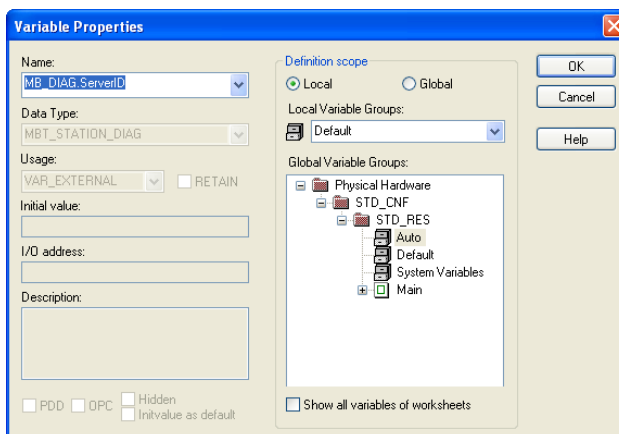

Figure 21-12 Creating the MB\_DIAG.ServerID variable (3)

4. Confirm your entries with “OK”.
5. The server ID of the “MB\_DIAG” diagnostic variable has now been assigned to the “ServerID” input parameter of the function block.

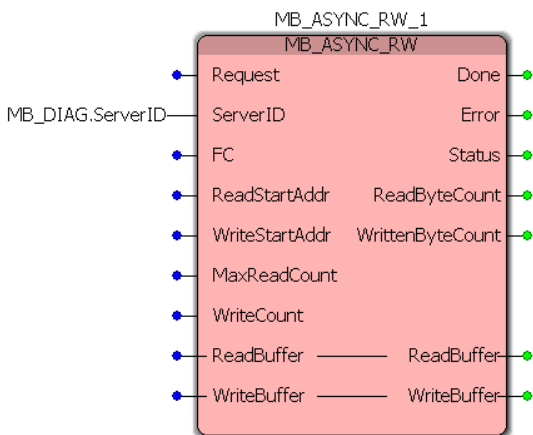

Figure 21-13 MB\_DIAG.ServerID variable as “ServerID” in the function block

### 21.4.3 Specifying the size of the ReadBuffer/WriteBuffer

The size of the “ReadBuffer” and “WriteBuffer” parameters can be specified individually by defining the corresponding data types.



For ReadBuffer and WriteBuffer, the maximum size is 250 bytes each.

1. Double-click on “sys\_flag\_types” in the project tree window.
2. Define the desired data types and their sizes as shown in Figure 21-14.

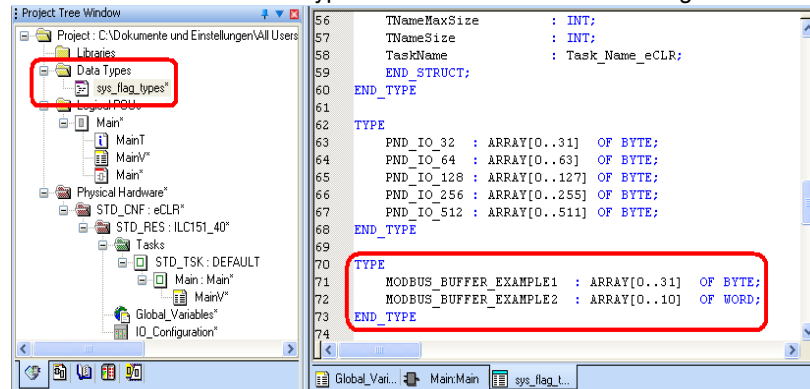

Figure 21-14 Creating data types

3. Once you have defined the data types, select the “Build, Make” command.

The data types can be used in the variable worksheet after compiling. In Figure 21-15, the previously created “MODBUS\_BUFFER\_EXAMPLE1” data type is used for the “ReadBuffer” input/output parameter.

4. Double-click on the “ReadBuffer” input parameter on the MB\_ASYNC\_RW\_1 function block.
5. In the “Variable Properties” window, enter a name for the variable (in the example: “ReadBuffer1”).
6. In the “Data Type” list, select the previously created data type you wish to use (in the example: “MODBUS\_BUFFER\_EXAMPLE1”).

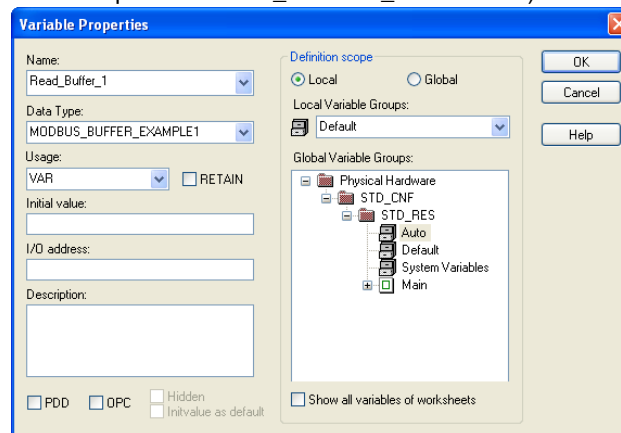

Figure 21-15 Creating a variable

**EM-MODBUS-GATEWAY-IFS used with the Phoenix Contact controllers**

7. Confirm your entries with “OK”.

The “ReadBuffer\_1” variable has now been assigned to the “ReadBuffer” input/output parameter.

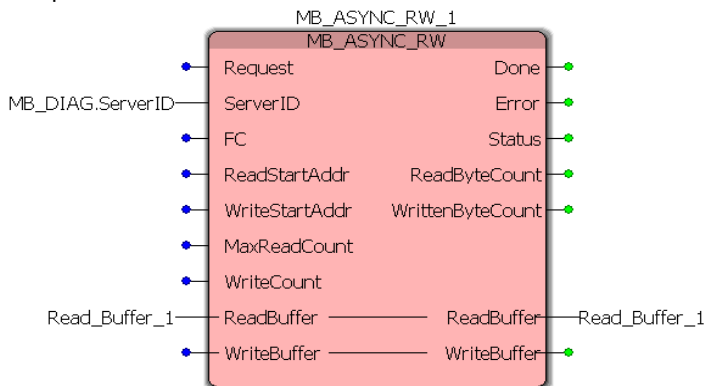

Figure 21-16 “ReadBuffer\_1” variable as “ReadBuffer” on the function block



For further information on user-defined data types and their use, please refer to the PC Worx online help.

## CONTACTRON motor management

---

## 22 Application examples

### 22.1 Example 1 - Without switching function, with power meter monitoring

The EMM module is to be used as a power meter. If the day counter reaches 20 kWh, output 1 should output a warning which is automatically acknowledged when the day counter is reset.

#### 22.1.1 Hardware configuration

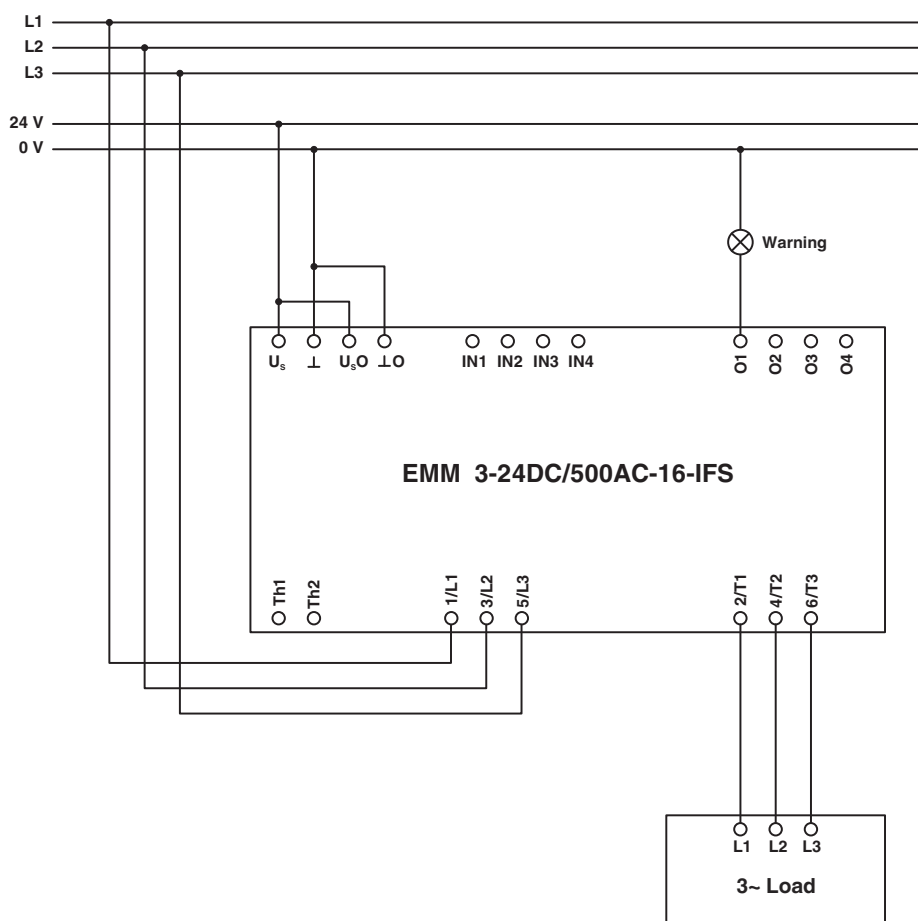

Figure 22-1 Hardware configuration example 1

**CONTACTRON motor management****22.1.2 Software configuration**

For this example, the following parameters must be changed in the DTM:

Dialog box	Parameter menu	Parameter	Set value
Configuration	Motor output - General Settings	Switching output type	Digital outputs, no switching function
	Monitoring - Monitoring 1	Activation	Always
		Monitoring signal	Energy meter reset
		Trigger at	Overrange
		Behavior	Generate message
		Acknowledgment	Manual
Online Parameter	Monitoring - Monitoring 1	Start-up suppression time	0 x 10 ms
		Set point	20 kWh
		Delay time	0 x 10 ms
	Outputs - Output 1	Monitoring 1	Enabled

## 22.2 Example 2 - Direct starter for pump monitoring

Dry running or blockages can occur when using pumps. To protect the pump motor and the pump, the motor real power can be monitored and the motor shut down or a message generated in the event of nominal value overrange or underrange.

Output 3 should be used as the pre-warning message output (overrange and underrange).

Output 4 should be used as the error message output (overrange and underrange).

### 22.2.1 Hardware configuration

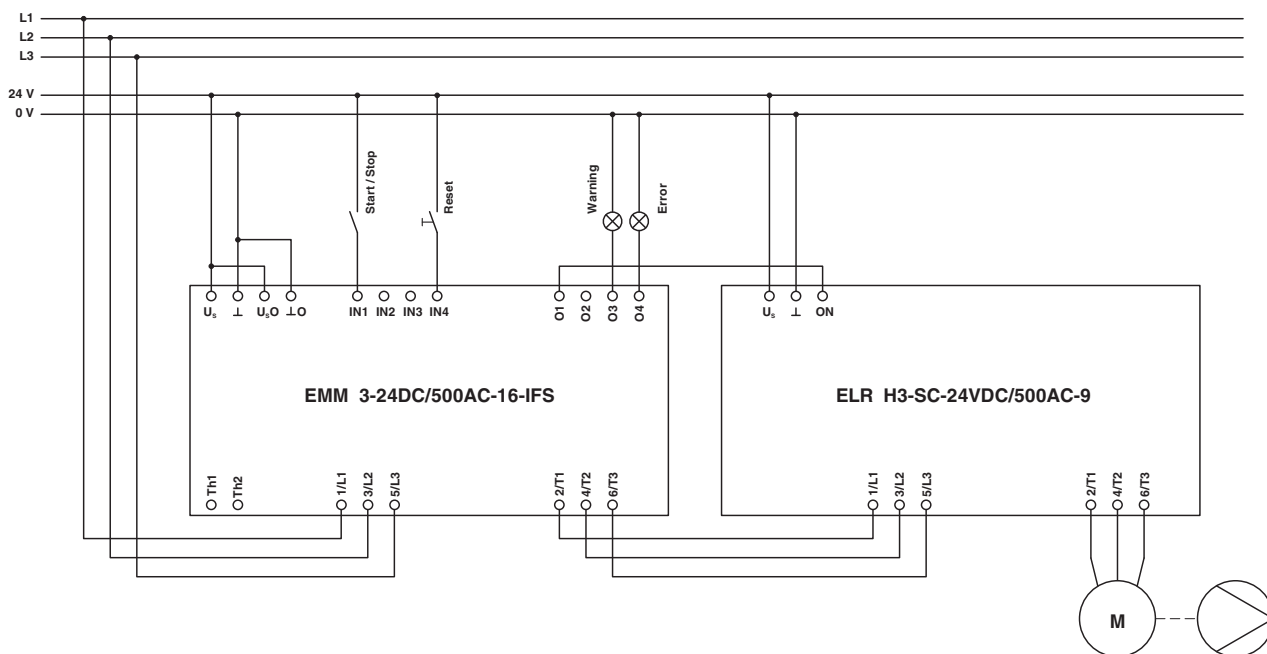

Figure 22-2 Hardware configuration example 2

**CONTACTRON motor management****22.2.2 Software configuration**

For this example, the following parameters must be changed in the DTM:

Dialog box	Parameter menu	Parameter	Set value
Configuration	Motor output - General Settings	Switching output type	Direct starter
	Monitoring - Monitoring 1 Early warning of dry running, e.g., air bubble	Activation	During right rotation
		Monitoring signal	Effective power : total
		Trigger at	Underrange
		Behavior	Generate message
		Acknowledgment	Automatic
	Monitoring - Monitoring 2 Shutdown in the event of dry running	Activation	During right rotation
		Monitoring signal	Effective power : total
		Trigger at	Underrange
		Behavior	Disable drive
	Monitoring - Monitoring 3 Early warning of blockage	Acknowledgment	Manual
		Activation	During right rotation
		Monitoring signal	Effective power : total
		Trigger at	Overrange
		Behavior	Generate message
	Monitoring - Monitoring 4 Shutdown in the event of blockage	Acknowledgment	Automatic
		Activation	During right rotation
		Monitoring signal	Effective power : total
		Trigger at	Overrange
		Behavior	Disable drive
		Acknowledgment	Manual

## Application examples

Dialog box	Parameter menu	Parameter	Set value
Online Parameter	Monitoring - Monitoring 1	Start-up suppression time	50 x 10 ms
		Set point	280 W
		Delay time	0 x 10 ms
	Monitoring - Monitoring 2	Start-up suppression time	200 x 10 ms
		Set point	250 W
		Delay time	200 x 10 ms
	Monitoring - Monitoring 3	Start-up suppression time	50 x 10 ms
		Set point	600 W
		Delay time	5 x 10 ms
	Monitoring - Monitoring 4	Start-up suppression time	200 x 10 ms
		Set point	620 W
		Delay time	200 x 10 ms
	Outputs - Output 3	Monitoring 1	Enabled
		Monitoring 3	Enabled
	Outputs - Output 4	Monitoring 2	Enabled
Monitoring 4		Enabled	

CONTACTRON motor management

### 22.3 Example 3 - Direct starter with current transformer

In this example, an 18.5 kW fan motor is to be controlled and monitored. Three 50 A transformers are required for this.

Output 3 should be used as the signal output for the running motor.

Output 4 should be used as the fault signal output for motor and thermistor errors.

#### 22.3.1 Hardware configuration

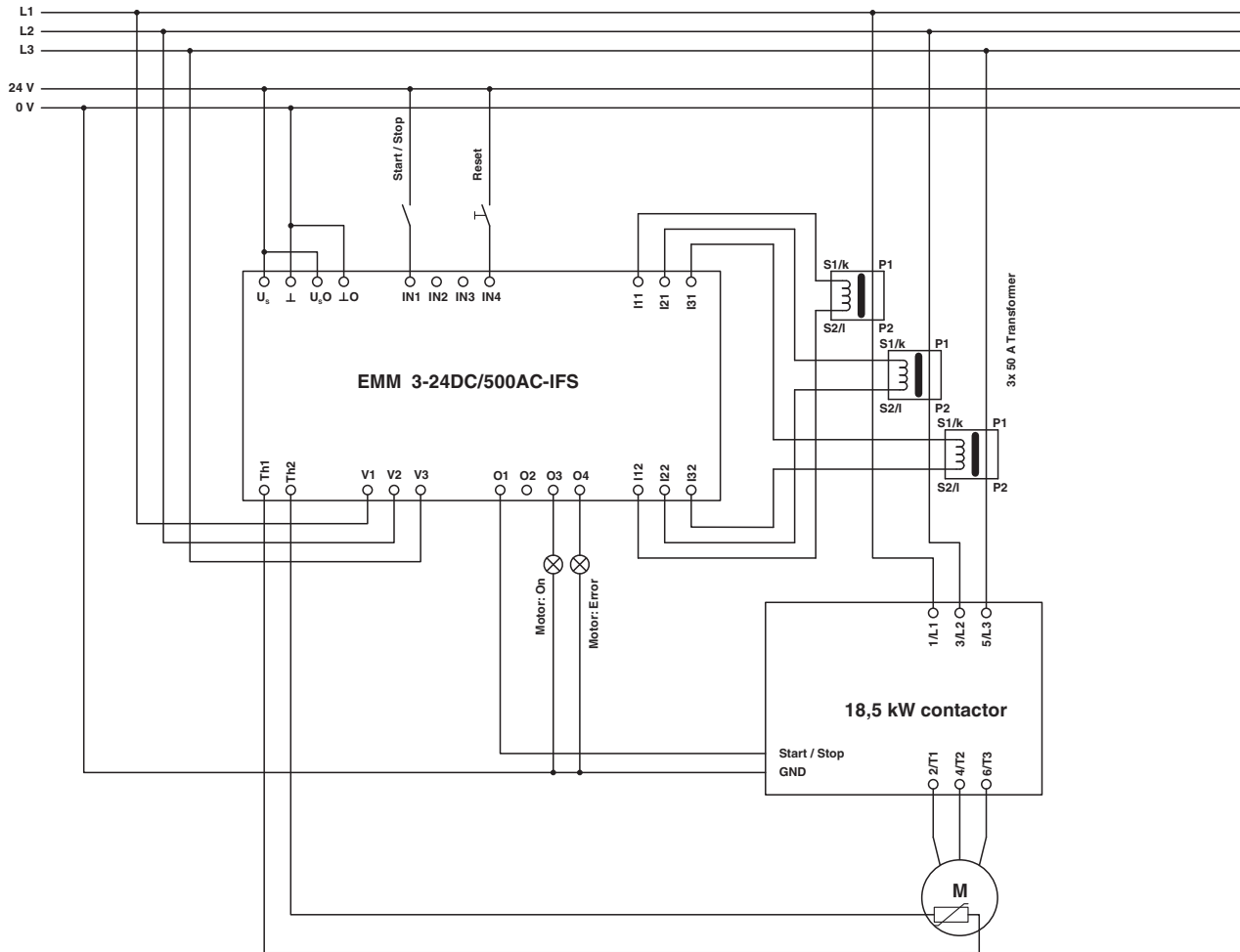

Figure 22-3 Hardware configuration example 3

### 22.3.2 Software configuration

For this example, the following parameters must be changed in the DTM:

Dialog box	Parameter menu	Parameter	Set value
Configuration	Current transformer	Count	3
		Amplitude transmission factor	10
	Motor output - General Settings	Switching output type	Direct starter
	Motor output - Bimetal	Tripping characteristic curve	10 A
		Cooling-down time	20 minutes
		Manual reset	1 minute
		Nominal motor current	36 A
		Behavior	Disable drive
		Acknowledgment	Manual
	Motor output - Thermistor	Overtemperature (behavior)	Disable drive
		Overtemperature (acknowledgment)	Manual
		Wire break (behavior)	Disable drive
		Wire break (acknowledgment)	Manual
		Short circuit (behavior)	Disable drive
		Short circuit (acknowledgment)	Manual
	Monitoring - Monitoring 1 Shutdown in the event of under- range, e.g., V-belt monitoring	Activation	During right and left rotation
		Monitoring signal	Effective power : total
		Trigger at	Underrange
		Behavior	Disable drive
		Acknowledgment	Manual
	Monitoring - Monitoring 2 Shutdown in the event of overrange, e.g., filter blocked	Activation	During right and left rotation
		Monitoring signal	Effective power : total
		Trigger at	Overrange
		Behavior	Disable drive
		Acknowledgment	Manual

**CONTACTRON motor management**

Dialog box	Parameter menu	Parameter	Set value
Online Parameter	Monitoring - Monitoring 1	Start-up suppression time	100 x 10 ms
		Set point	15000 W
		Delay time	100 x 10 ms
	Monitoring - Monitoring 2	Start-up suppression time	100 x 10 ms
		Set point	19000 W
		Delay time	100 x 10 ms
	Outputs - Output 3	Feedback: Motor right rotation	Enabled
		Feedback: Motor left rotation	Enabled
	Outputs - Output 4	Monitoring 1	Enabled
		Monitoring 2	Enabled
		Thermistor overtemperature	Enabled
		Thermistor short circuit	Enabled
Thermistor wire break		Enabled	

## 22.4 Example 4 - Reversing starter in potentially explosive areas (ATEX)

In this example, a motor is controlled in an EEx area in right/left mode. In addition to the normal reversing starter, EEx-relevant data must be set here.

### 22.4.1 Hardware configuration

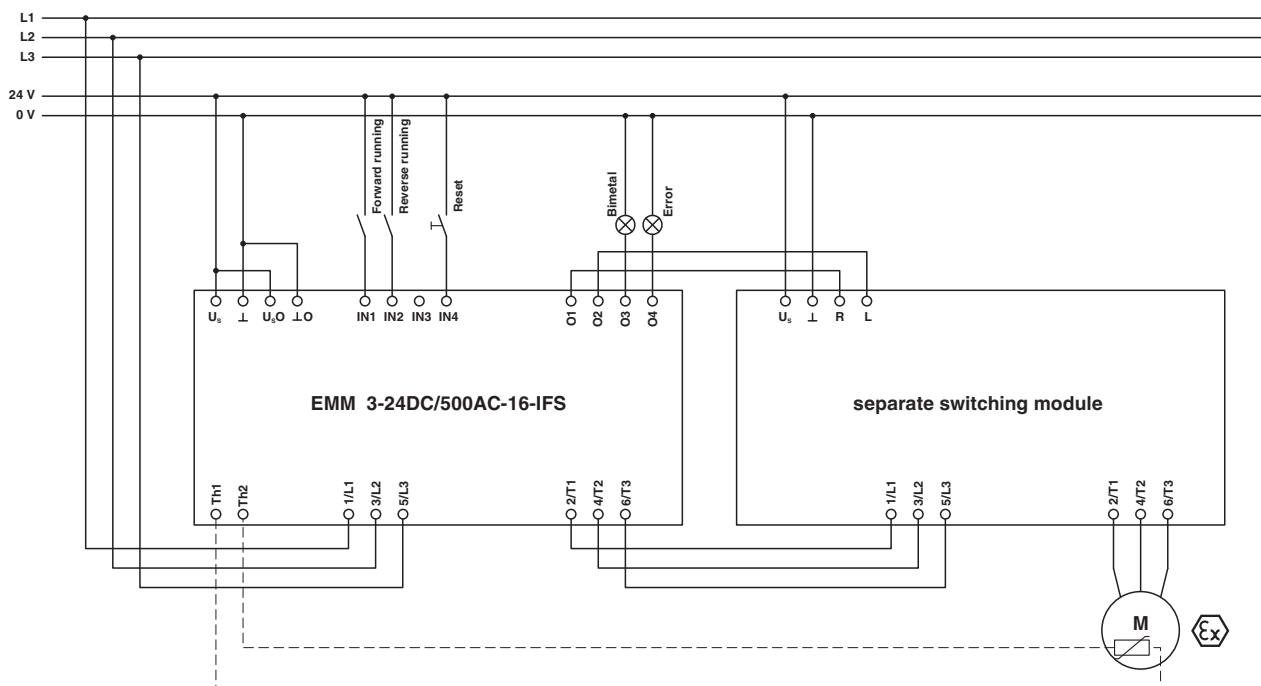

Figure 22-4 Hardware configuration example 4

**CONTACTRON motor management****22.4.2 Software configuration**

For this example, the following parameters must be changed in the DTM:

Dialog box	Parameter menu	Parameter	Set value		
Configuration	Configuration	Field of application	ATEX		
	Motor output - General Settings	Switching output type	Reversing starter		
	Motor output - Bimetal	Tripping characteristic curve	Cooling-down time	20 minutes	
			Manual reset	1 minute	
			Nominal motor current	Refer to motor rating plate for value	
			Behavior	Disable drive	
			Acknowledgment	Manual	
			Motor output - Thermistor (optional)	Overtemperature (behavior)	Disable drive
			Overtemperature (acknowledgment)	Manual	
	Motor output - Thermistor (optional)	Wire break (behavior)	Wire break (acknowledgment)	Manual	
			Short circuit (behavior)	Disable drive	
			Short circuit (acknowledgment)	Manual	
			Monitoring - Monitoring 1 Shutdown in the event of under-range	Activation	During right and left rotation
				Monitoring signal	Effective power : total
				Trigger at	Underrange
	Behavior	Disable drive			
	Monitoring - Monitoring 2 Shutdown in the event of overrange	Acknowledgment	Activation	During right and left rotation	
			Monitoring signal	Effective power : total	
			Trigger at	Overrange	
			Behavior	Disable drive	
			Acknowledgment	Manual	

## Application examples

Dialog box	Parameter menu	Parameter	Set value
Online Parameter	Monitoring - Monitoring 1	Start-up suppression time	100 x 10 ms
		Set point	250 W
		Delay time	100 x 10 ms
	Monitoring - Monitoring 2	Start-up suppression time	100 x 10 ms
		Set point	350 W
		Delay time	100 x 10 ms
	Outputs - Output 3	Bimetal monitoring	Enabled
	Outputs - Output 4	Monitoring 1	Enabled
		Monitoring 2	Enabled
		Thermistor overtemperature (optional)	Enabled
		Thermistor wire break (optional)	Enabled
Thermistor short circuit (optional)		Enabled	

CONTACTRON motor management

## 22.5 Example 5 - Star/delta

Example structure of a star/delta combination.

### 22.5.1 Hardware configuration

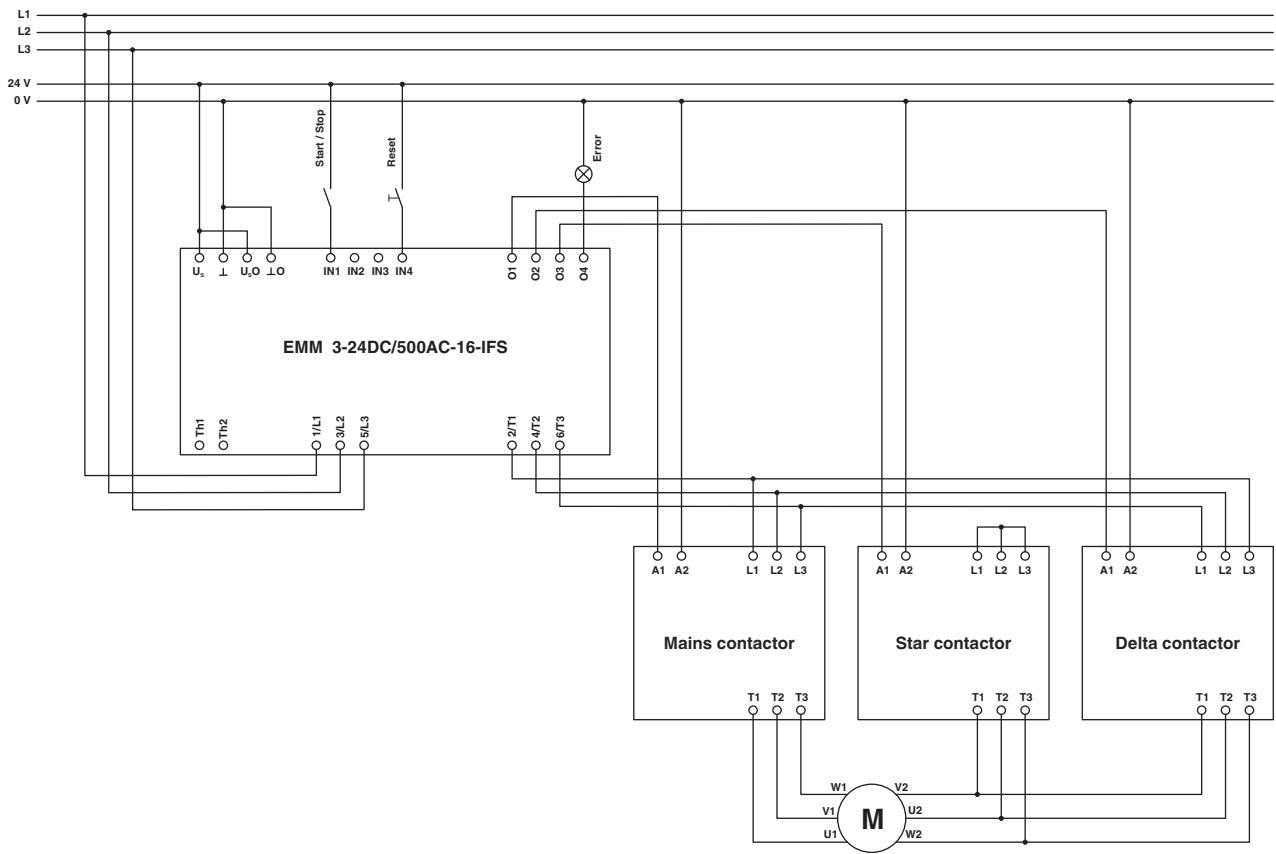

Figure 22-5 Hardware configuration example 5

## 22.5.2 Software configuration

For this example, the following parameters must be changed in the DTM:

Dialog box	Parameter menu	Parameter	Set value	
Configuration	Motor output - General Settings	Switching output type	Star/delta	
		Motor output - Bimetal	Tripping characteristic curve	10 A
	Cooling-down time		20 minutes	
	Manual reset		1 minute	
	Nominal motor current		Refer to motor rating plate for value	
	Behavior		Disable drive	
	Acknowledgment		Manual	
	Monitoring - Monitoring 1 Shutdown in the event of under-range	Activation	During right and left rotation	
		Monitoring signal	Effective power : total	
		Trigger at	Overrange	
		Behavior	Disable drive	
		Acknowledgment	Manual	
	Monitoring - Monitoring 2 Shutdown in the event of overrange	Activation	During right and left rotation	
		Monitoring signal	Effective power : total	
		Trigger at	Overrange	
		Behavior	Disable drive	
		Acknowledgment	Manual	
	Online Parameter	Motor output - Star-Delta	Maximal time at star operation	10 x 10 ms
			Change-over delay at changing from star to delta operation	10 x 10 ms
Monitoring - Monitoring 1		Start-up suppression time	100 x 10 ms	
		Set point	250 W	
		Delay time	100 x 10 ms	
Monitoring - Monitoring 2		Start-up suppression time	100 x 10 ms	
		Set point	350 W	
		Delay time	100 x 10 ms	
Outputs - Output 4		Bimetal monitoring	Enabled	
		Monitoring 1	Enabled	
		Monitoring 2	Enabled	

CONTACTRON motor management

## 22.6 Example 6 - Star/delta LR

Example structure of a star/delta combination for right/left rotation.

### 22.6.1 Hardware configuration

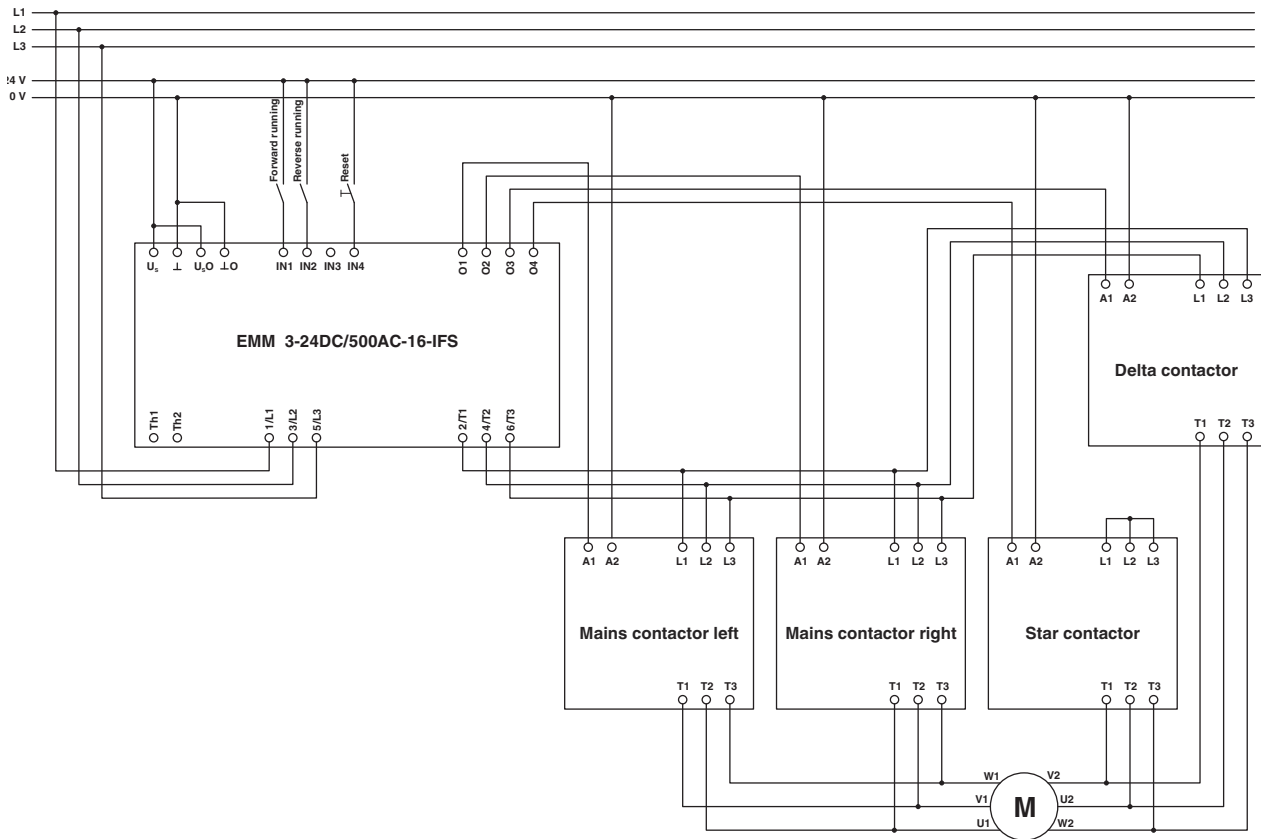

Figure 22-6 Hardware configuration example 6

## 22.6.2 Software configuration

For this example, the following parameters must be changed in the DTM:

Dialog box	Parameter menu	Parameter	Set value
Configuration	Motor output - General Settings	Switching output type	Star/delta LR
		Motor output - Bimetal	Tripping characteristic curve
	Cooling-down time		20 minutes
	Manual reset		1 minute
	Nominal motor current		Refer to motor rating plate for value
	Behavior		Disable drive
	Acknowledgment		Manual
	Monitoring - Monitoring 1 Shutdown in the event of under-range	Activation	During right and left rotation
		Monitoring signal	Effective power : total
		Trigger at	Overrange
		Behavior	Disable drive
		Acknowledgment	Manual
	Monitoring - Monitoring 2 Shutdown in the event of over-range	Activation	During right and left rotation
		Monitoring signal	Effective power : total
		Trigger at	Overrange
		Behavior	Disable drive
Acknowledgment		Manual	
Online Parameter	Motor output - Star-Delta	Maximal time at star operation	10 x 10 ms
		Change-over delay at changing from star to delta operation	10 x 10 ms
	Monitoring - Monitoring 1	Start-up suppression time	100 x 10 ms
		Set point	250 W
		Delay time	100 x 10 ms
	Monitoring - Monitoring 2	Start-up suppression time	100 x 10 ms
		Set point	350 W
		Delay time	100 x 10 ms

## 22.7 Example 7 - Reversing starter with connection to PROFIBUS

The EM-PB-GATEWAY-IFS is required in order to connect the EMM module to PROFIBUS. It is connected to the bottom of both modules using the TBUS connection.

For information about integrating the EM-PB-GATEWAY-IFS in PROFIBUS and STEP 7, please refer to Section "Integration in STEP 7 with PROFIBUS communication" on page 255.

### 22.7.1 Hardware configuration

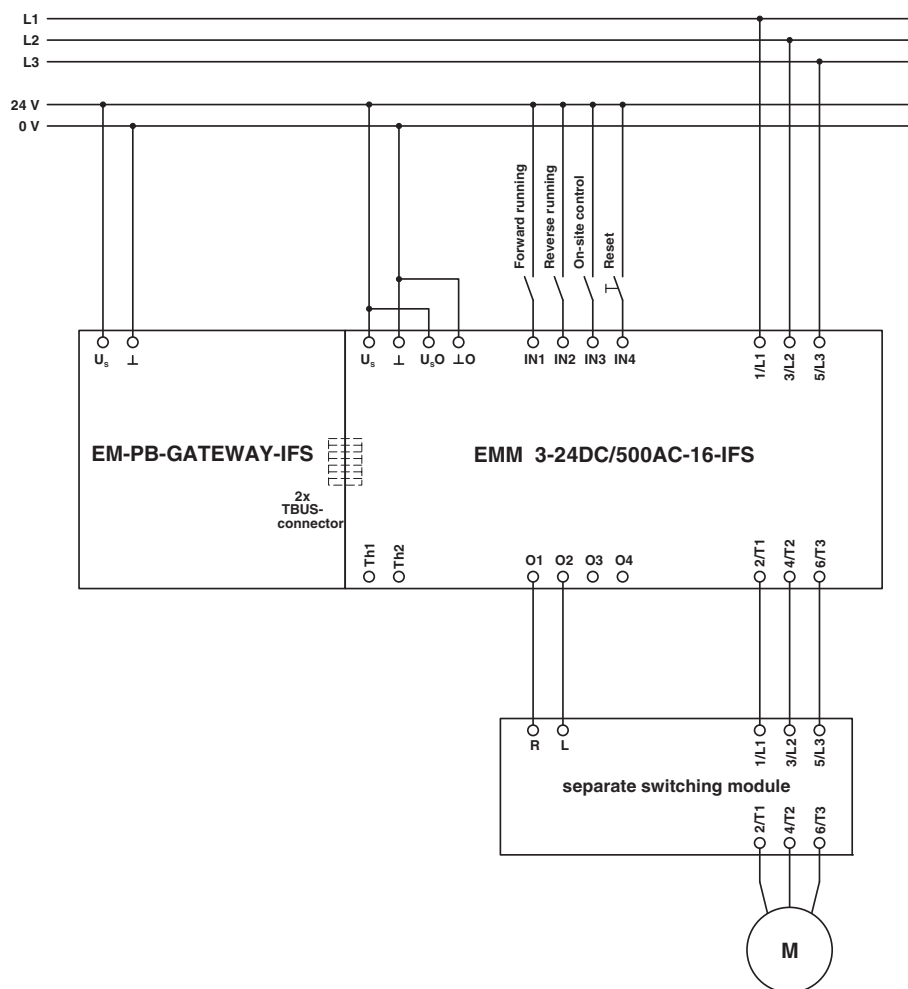

Figure 22-7 Hardware configuration example 7

## 22.7.2 Software configuration

For this example, the following parameters must be changed in the DTM:

Dialog box	Parameter menu	Parameter	Set value	
Configuration	Motor output - General Settings	Switching output type	Reversing starter	
	Motor output - Bimetal	Tripping characteristic curve	10 A	
		Cooling-down time	20 minutes	
		Manual reset	1 minute	
		Nominal motor current	Refer to motor rating plate	
		Behavior	Disable drive	
		Acknowledgment	Manual	
	Monitoring - Monitoring 1 Shutdown in the event of under-range	Activation	During right and left rotation	
		Monitoring signal	Effective power : total	
		Trigger at	Underrange	
		Behavior	Disable drive	
		Acknowledgment	Manual	
	Monitoring - Monitoring 2 Shutdown in the event of over-range	Activation	During right and left rotation	
		Monitoring signal	Effective power : total	
		Trigger at	Overrange	
		Behavior	Disable drive	
		Acknowledgment	Manual	
	Online Parameter	Monitoring - Monitoring 1	Start-up suppression time	100 x 10 ms
			Set point	350 W
Delay time			100 x 10 ms	
Monitoring - Monitoring 2		Start-up suppression time	100 x 10 ms	
		Set point	350 W	
		Delay time	100 x 10 ms	
Outputs - Output 3		Feedback: Motor right rotation	Enabled	
		Feedback: Motor left rotation	Enabled	
Outputs - Output 4		Monitoring 1	Enabled	
		Monitoring 2	Enabled	
		Thermistor overtemperature	Enabled	
	Thermistor short circuit	Enabled		
	Thermistor wire break	Enabled		

CONTACTRON motor management

## 22.8 Example 8 - 690 V reversing starter with voltage transducer

To monitor 690 V networks, use the voltage transducer (UT 4-MTDR/ CVC 690/SET, Order No. 2901667).

### 22.8.1 Hardware configuration

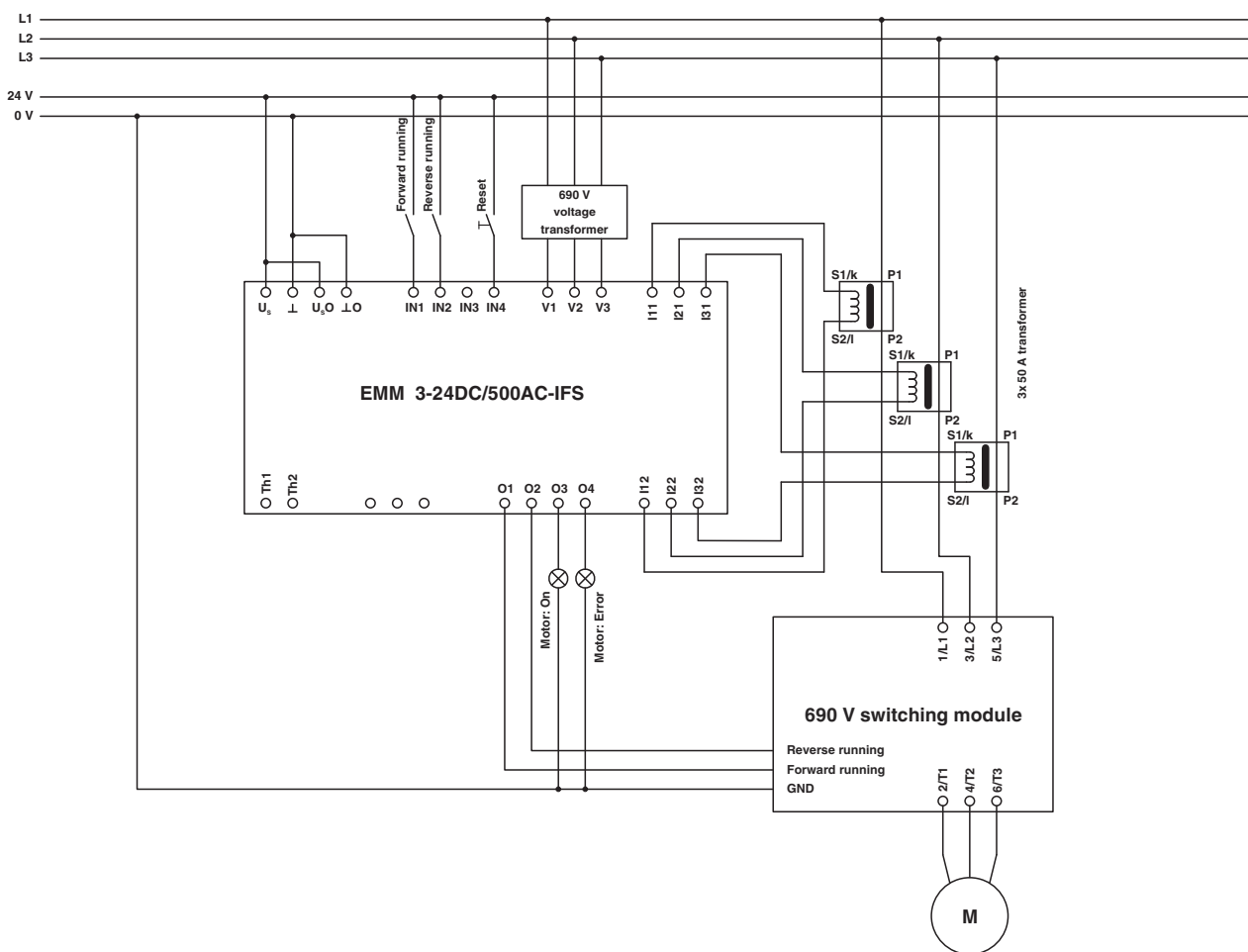

Figure 22-8 Hardware configuration example 8

## 22.8.2 Software configuration

For this example, the following parameters must be changed in the DTM:

Dialog box	Parameter menu	Parameter	Set value
Configuration	Voltage transformer	Voltage transformer	690 V AC
	Current transformer	Count	3
		Amplitude transmission factor	10
	Motor output - General Settings	Switching output type	Reversing starter
	Motor output - Bimetal	Tripping characteristic curve	10 A
		Cooling-down time	20 minutes
		Manual reset	1 minute
		Nominal motor current	Refer to motor rating plate for value
		Behavior	Disable drive
		Acknowledgment	Manual
	Monitoring - Monitoring 1 Shutdown in the event of under-range	Activation	During right and left rotation
		Monitoring signal	Effective power : total
		Trigger at	Underrange
		Behavior	Disable drive
		Acknowledgment	Manual
	Monitoring - Monitoring 2 Shutdown in the event of over-range	Activation	During right and left rotation
		Monitoring signal	Effective power : total
		Trigger at	Overrange
		Behavior	Disable drive
		Acknowledgment	Manual

**CONTACTRON motor management**

Dialog box	Parameter menu	Parameter	Set value
Online Parameter	Monitoring - Monitoring 1	Start-up suppression time	100 x 10 ms
		Set point	350 W
		Delay time	100 x 10 ms
	Monitoring - Monitoring 2	Start-up suppression time	100 x 10 ms
		Set point	350 W
		Delay time	100 x 10 ms
	Outputs - Output 3	Feedback: Motor right rotation	Enabled
		Feedback: Motor left rotation	Enabled
	Outputs - Output 4	Monitoring 1	Enabled
		Monitoring 2	Enabled
		Thermistor overtemperature	Enabled
		Thermistor short circuit	Enabled
		Thermistor wire break	Enabled

## 23 Appendixes

### 23.1 List of figures

#### Section 1

Figure 1-1:	Example of broken tool .....	14
Figure 1-2:	Example of dry running .....	15

#### Section 2

Figure 2-1:	EMM 3-.../500AC...-IFS .....	19
Figure 2-2:	Block diagram .....	22
Figure 2-3:	EMM 3-.../500AC-16-IFS for line currents up to 16 A .....	23
Figure 2-4:	EMM 3-.../500AC-IFS for currents >16 A .....	25
Figure 2-5:	Derating curves, EMM 3- 24DC/... .....	32
Figure 2-6:	Derating curves, EMM 3-230AC/... .....	33
Figure 2-7:	Tripping characteristic for 20°C (blocking protection) .....	34
Figure 2-8:	Shutdown time .....	35

#### Section 4

Figure 4-1:	Internal wiring of the terminal points .....	55
Figure 4-2:	Terminal point assignment and connection diagram of the Inline and COMBICON connectors .....	56
Figure 4-3:	Diagnostic and status indicators .....	58
Figure 4-4:	DIP switch for setting the data width .....	60
Figure 4-5:	Connection example .....	62
Figure 4-6:	S-PORT and button .....	64

#### Section 5

Figure 5-1:	EM-PB-GATEWAY-IFS .....	67
Figure 5-2:	PROFIBUS module for electronic motor management modules .....	68
Figure 5-3:	Block diagram .....	70
Figure 5-4:	Operating and indication elements .....	71

#### Section 6

Figure 6-1:	Operating and indication elements .....	84
-------------	---	----

**CONTACTRON motor management**

---

**Section 7**

Figure 7-1: Operating and indication elements ..... 94

**Section 8**

Figure 8-1: Operating and indication elements ..... 104

**Section 9**

Figure 9-1: Operating and indication elements ..... 110

**Section 10**

Figure 10-1: Operating and indication elements ..... 118

**Section 11**

Figure 11-1: Operating and indication elements ..... 126

**Section 12**

Figure 12-1: Operating and indication elements ..... 134

**Section 13**

Figure 13-1: Operating and indication elements ..... 139

**Section 14**

Figure 14-1: TBUS DIN rail connector ..... 143

Figure 14-2: Mounting/removal ..... 143

**Section 15**

Figure 15-1: Recommended restart time ..... 150

**Section 16**

Figure 16-1: IFS-USB-PROG-ADAPTER ..... 153

Figure 16-2: Connection to the PC ..... 154

Figure 16-3: Connection to the device ..... 154

Figure 16-4: Installation wizard ..... 155

Figure 16-5: Software icon ..... 156

---

**List of figures**

Figure 16-6:	Creating a user when starting the software for the first time .....	156
Figure 16-7:	Searching for known DTMs .....	157
Figure 16-8:	Displaying known DTMs .....	157
Figure 16-9:	DTM Catalog Management .....	158
Figure 16-10:	Topology scan .....	158
Figure 16-11:	Topology Scan Wizard .....	159
Figure 16-12:	Project tree .....	159
Figure 16-13:	Opening device management .....	160
Figure 16-14:	Device management .....	160
Figure 16-15:	Reading the hardware structure .....	161
Figure 16-16:	Downloading parameters .....	161
Figure 16-17:	Selecting "Options" .....	162
Figure 16-18:	"Individual Name" options .....	162
Figure 16-19:	Process data configuration .....	163
Figure 16-20:	Device selection .....	164
Figure 16-21:	Writing project data to the modules .....	165
Figure 16-22:	Monitoring .....	166
Figure 16-23:	Displaying process values in the "Observe" window .....	167
Figure 16-24:	CAN gateway settings .....	168
Figure 16-25:	ETH gateway settings - configuration .....	169
Figure 16-26:	ETH gateway settings - Ethernet .....	170
Figure 16-27:	ETH gateway setting - authentication .....	171
Figure 16-28:	ETH gateway settings - Ethernet/IP .....	172
Figure 16-29:	RS-232 gateway settings .....	173
Figure 16-30:	RS-485 gateway settings .....	174
Figure 16-31:	EM-PB-GATEWAY-IFS settings .....	175
Figure 16-32:	PROFINET gateway settings - configuration .....	176
Figure 16-33:	PROFINET gateway settings - Ethernet .....	177
Figure 16-34:	PROFINET gateway setting - authentication .....	178
Figure 16-35:	Modbus gateway settings - configuration .....	179
Figure 16-36:	Modbus gateway settings - Ethernet .....	180
Figure 16-37:	Modbus gateway settings - authentication .....	181
Figure 16-38:	Modbus gateway settings - Modbus/TCP .....	182
Figure 16-39:	DeviceNet gateway settings .....	183
Figure 16-40:	Opening the diagnostics dialog box .....	184
Figure 16-41:	Tab 1 of the gateway diagnostics dialog box .....	185
Figure 16-42:	Tab 2 of the gateway diagnostics dialog box .....	186

## CONTACTRON motor management

---

Figure 16-43:	Saving the project .....	187
Figure 16-44:	Activated online connection to the EMM 3- xx/500AC/xx-IFS module .....	188
Figure 16-45:	Overview of the general parameters .....	193
Figure 16-46:	“Voltage transformer” configuration dialog box .....	195
Figure 16-47:	“Current transformer” configuration dialog box .....	196
Figure 16-48:	“Voltage monitoring” configuration dialog box .....	197
Figure 16-49:	“Phase monitoring” configuration dialog box .....	199
Figure 16-50:	“Symmetry monitoring” configuration dialog box .....	200
Figure 16-51:	“Motor output” configuration dialog box .....	201
Figure 16-52:	Program side default setting of inputs and outputs .....	202
Figure 16-53:	“Bimetal” configuration dialog box .....	203
Figure 16-54:	Tripping characteristic at 20°C (blocking protection) .....	204
Figure 16-55:	“ShortToGround Detection” configuration dialog box .....	205
Figure 16-56:	“Thermistor” configuration dialog box .....	206
Figure 16-57:	“Execution time” configuration dialog box .....	208
Figure 16-58:	“Response time” configuration dialog box .....	209
Figure 16-59:	“Starts per time monitoring“ configuration dialog box .....	210
Figure 16-60:	“Monitoring” configuration dialog box .....	211
Figure 16-61:	“INTERFACE-System” configuration dialog box .....	214
Figure 16-62:	Message when switching to the “Online Parameter” dialog box .....	215
Figure 16-63:	“Min. switchover delay time” parameter dialog box .....	216
Figure 16-64:	“Reversing pulse length” parameter dialog box .....	217
Figure 16-65:	“Star-Delta” parameter dialog box .....	218
Figure 16-66:	“General Settings” parameter dialog box .....	219
Figure 16-67:	“Starts per time monitoring” parameter dialog box .....	220
Figure 16-68:	“Output behavior” parameter dialog box .....	221
Figure 16-69:	“Monitoring 1 ... 8” parameter dialog box .....	222
Figure 16-70:	Underload example .....	223
Figure 16-71:	Overload example .....	224
Figure 16-72:	“Outputs 1 ... 8” parameter dialog box .....	225
Figure 16-73:	Writing the configuration to the device .....	228
Figure 16-74:	“Overview” monitoring dialog box .....	230
Figure 16-75:	“Online values” monitoring dialog box .....	231
Figure 16-76:	Representation of online values .....	232
Figure 16-77:	Dialog box, save as .....	233
Figure 16-78:	Dialog box, open file .....	234
Figure 16-79:	Dialog box, export file .....	234

Figure 16-80:	“Counter” monitoring dialog box .....	235
Figure 16-81:	“Messages / errors” monitoring dialog box .....	236

## Section 17

Figure 17-1:	Features in the setup .....	240
Figure 17-2:	Activating a feature .....	240
Figure 17-3:	CONTACTRON DTM - Selection for CONTACTRON motor management .....	241
Figure 17-4:	Search progress .....	241
Figure 17-5:	Integrating DTMs in the device catalog .....	242
Figure 17-6:	Device catalog after import .....	242
Figure 17-7:	View, Connected Bus .....	243
Figure 17-8:	Connected bus .....	244
Figure 17-9:	Importing the device into the project .....	244
Figure 17-10:	Local bus read in .....	244
Figure 17-11:	Selecting the Interface master with a correct ID/PD .....	245
Figure 17-12:	Bus configuration with IB IL IFS-MA-PAC .....	245
Figure 17-13:	Selecting the EMM .....	246
Figure 17-14:	Complete bus configuration .....	246
Figure 17-15:	Assigning a device address for EMMs .....	246
Figure 17-16:	Calling DTM functions .....	247
Figure 17-17:	Connection symbols (top: devices not connected, bottom left: device actively connected, bottom right: device connected) .....	247
Figure 17-18:	DTM functions of the controller .....	248
Figure 17-19:	DTM functions: Controller device list .....	248
Figure 17-20:	DTM functions of the IB IL IFS-MA-PAC .....	249
Figure 17-21:	CONTACTRON motor management device list .....	249
Figure 17-22:	Start the naming process .....	250
Figure 17-23:	Initializing the device naming process .....	250
Figure 17-24:	Time remaining for naming .....	250
Figure 17-25:	Naming carried out successfully .....	250
Figure 17-26:	Naming has not been carried out .....	250
Figure 17-27:	Connecting process data .....	251
Figure 17-28:	INTERBUS input data is connected .....	252
Figure 17-29:	INTERBUS output data is connected .....	252
Figure 17-30:	Displayed data of an EMM - Overview .....	253
Figure 17-31:	Displayed data of an EMM - Online values .....	253

**CONTACTRON motor management**

---

Figure 17-32:	EMM options .....	254
Figure 17-33:	Offline parameters .....	254

**Section 18**

Figure 18-1:	Flow chart .....	255
Figure 18-2:	Selecting "Downloads" in the online catalog .....	255
Figure 18-3:	Selecting the GSD file in the online catalog .....	256
Figure 18-4:	General terms and conditions of use .....	256
Figure 18-5:	Saving the GSD file .....	256
Figure 18-6:	SIMATIC Manager icon .....	256
Figure 18-7:	Creating a new project .....	257
Figure 18-8:	Saving the project name .....	257
Figure 18-9:	Selecting the CPU .....	258
Figure 18-10:	Selected CPU .....	258
Figure 18-11:	Opening the object .....	258
Figure 18-12:	Hardware configuration .....	259
Figure 18-13:	Hardware configuration .....	259
Figure 18-14:	Installing a GSD file .....	259
Figure 18-15:	"Die Installation wurde erfolgreich beendet" ("Installation has been completed successfully") message .....	260
Figure 18-16:	Opening the object .....	260
Figure 18-17:	Selecting the catalog .....	260
Figure 18-18:	Catalog window .....	261
Figure 18-19:	Selecting the DIN rail .....	261
Figure 18-20:	Selecting the CPU .....	262
Figure 18-21:	Bus line name .....	262
Figure 18-22:	Selecting the gateway .....	263
Figure 18-23:	Gateway properties .....	263
Figure 18-24:	GSD data .....	264
Figure 18-25:	Setting the byte order .....	265
Figure 18-26:	Example: Value "EMM: COS $\varphi$ " .....	265
Figure 18-27:	Hardware structure .....	268
Figure 18-28:	Opening the context menu of the EM-PB-GATEWAY-IFS .....	270
Figure 18-29:	Object properties of the EM-PB-GATEWAY-IFS .....	270
Figure 18-30:	Variable overview .....	271

---

## Section 19

Figure 19-1:	Flow chart .....	273
Figure 19-2:	CoDeSys icon .....	274
Figure 19-3:	Creating a new project .....	274
Figure 19-4:	“New Project” dialog box .....	275
Figure 19-5:	Selecting the controller and the preferred programming language ...	275
Figure 19-6:	Communication settings .....	276
Figure 19-7:	Adding a gateway .....	276
Figure 19-8:	Scanning the network .....	277
Figure 19-9:	Setting the active path .....	277
Figure 19-10:	Adding a device .....	278
Figure 19-11:	Add Device dialog box – Ethernet adapter .....	279
Figure 19-12:	Add Device dialog box - Modbus/TCP master .....	280
Figure 19-13:	Add Device dialog box - Modbus slave .....	281
Figure 19-14:	Properties of the Modbus/TCP slave .....	282
Figure 19-15:	Modbus/TCP slave settings .....	282
Figure 19-16:	Modbus slave channel .....	283
Figure 19-17:	Modbus channel - Inputs .....	284
Figure 19-18:	Modbus channel - Outputs .....	285
Figure 19-19:	Variables assignment .....	285
Figure 19-20:	Assigning the input and output words .....	286
Figure 19-21:	PLC_PRG block .....	287
Figure 19-22:	Example program in ST .....	287
Figure 19-23:	Translating the application and downloading it to the controller .....	288

## Section 20

Figure 20-1:	Hardware installation tool .....	289
Figure 20-2:	Hardware installation tool .....	289
Figure 20-3:	Creating a project .....	290
Figure 20-4:	Selecting the controller .....	290
Figure 20-5:	Integrating the new module .....	291
Figure 20-6:	Selecting a module type .....	291
Figure 20-7:	Describing the module .....	292
Figure 20-8:	Module definition .....	292
Figure 20-9:	Device in the project tree .....	293
Figure 20-10:	Transmittable process data .....	293

## CONTACTRON motor management

---

### Section 21

Figure 21-1:	Sequence for creating the Modbus project .....	297
Figure 21-2:	Selecting the Modbus device .....	299
Figure 21-3:	Generic Modbus device inserted .....	299
Figure 21-4:	Modbus settings of the EM-MODBUS-GATEWAY-IFS device .....	300
Figure 21-5:	Creating process data and assigning Modbus function codes .....	302
Figure 21-6:	All process data used are assigned to the variables .....	302
Figure 21-7:	Generating diagnostic and control variables .....	303
Figure 21-8:	Process data assigned to the control and diagnostic variables .....	303
Figure 21-9:	MB_ASYNC_RW function block .....	305
Figure 21-10:	Creating the MB_DIAG.ServerID variable (1) .....	308
Figure 21-11:	Creating the MB_DIAG.ServerID variable (2) .....	308
Figure 21-12:	Creating the MB_DIAG.ServerID variable (3) .....	309
Figure 21-13:	MB_DIAG.ServerID variable as "ServerID" in the function block .....	309
Figure 21-14:	Creating data types .....	310
Figure 21-15:	Creating a variable .....	310
Figure 21-16:	"ReadBuffer_1" variable as "ReadBuffer" on the function block .....	311

### Section 22

Figure 22-1:	Hardware configuration example 1 .....	313
Figure 22-2:	Hardware configuration example 2 .....	315
Figure 22-3:	Hardware configuration example 3 .....	318
Figure 22-4:	Hardware configuration example 4 .....	321
Figure 22-5:	Hardware configuration example 5 .....	324
Figure 22-6:	Hardware configuration example 6 .....	326
Figure 22-7:	Hardware configuration example 7 .....	328
Figure 22-8:	Hardware configuration example 8 .....	330



# SCATTERGOOD & JOHNSON LTD

ELECTRICAL ENGINEERING & FLUID CONTROL DISTRIBUTORS

Est.1899

At Scattergood & Johnson Ltd, we pride ourselves on being a technical distributor to specialist industries.

Working with a range of quality product suppliers across a number of specialist markets, we are not your average 'box shifter' - we are your technical and supply chain partner.

We fully support every product we sell - for free! Our internal team and external sales engineers can answer any product or application question, no matter the complexity.

Backing up this technical ability is a range of 50,000+ products available from stock for nationwide next day delivery (same day if required!), or you can collect what you need from any of our trade counters around the UK.

Select your specialist interest below to learn more about how we can help.

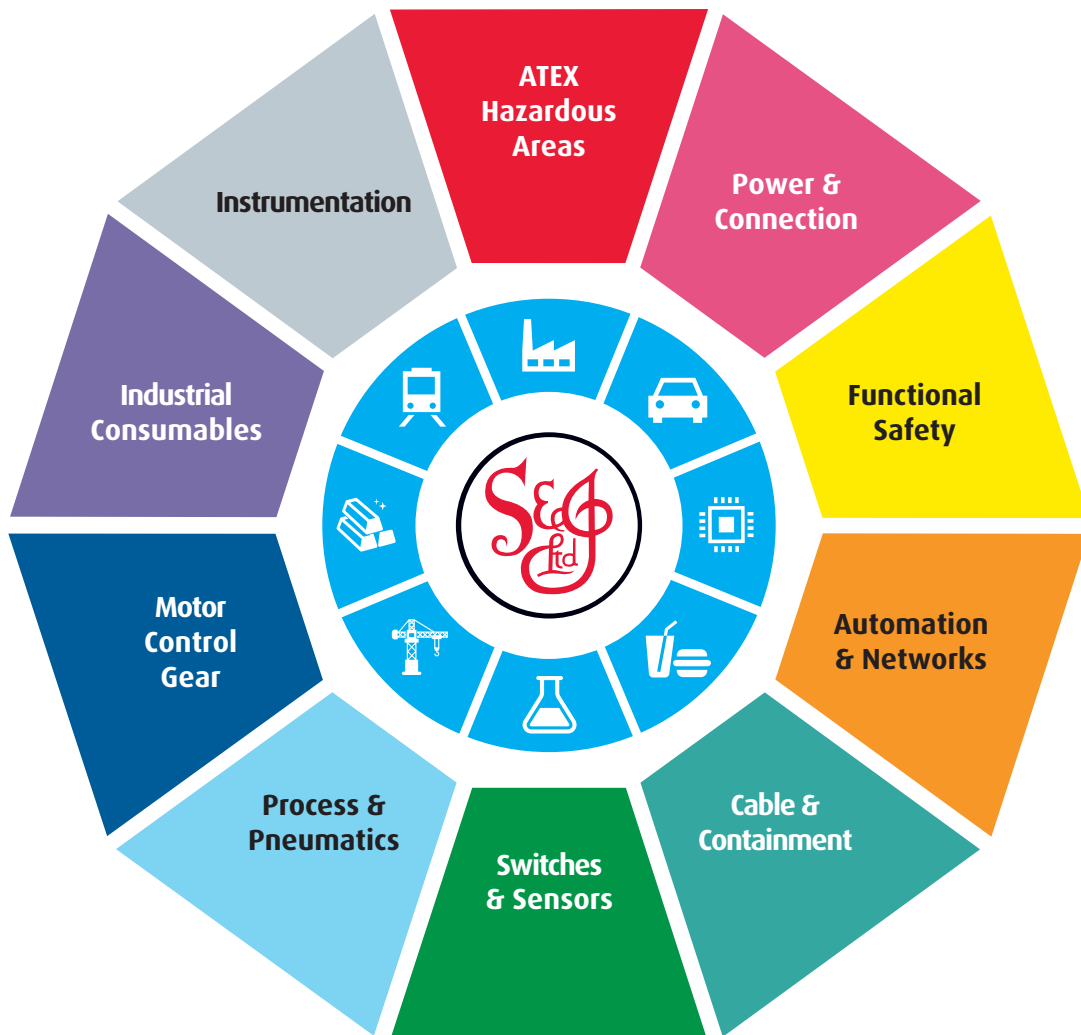

Online, In Branch and On the Road - Scattergood & Johnson Ltd, there when you need us.

# [www.scatts.co.uk](http://www.scatts.co.uk)