

Data interface - EM-ETH-GATEWAY-IFS - 2901988

Please be informed that the data shown in this PDF Document is generated from our Online Catalog. Please find the complete data in the user's documentation. Our General Terms of Use for Downloads are valid (<http://phoenixcontact.com/download>)



Gateway for the connection of up to 32 INTERFACE system devices to a higher-level controller via EtherNet/IP™. The INTERFACE system devices are connected to the Gateway via DIN rail connectors, the DIN rail connectors are provided.



Key Commercial Data

Packing unit	1 pc
GTIN	
GTIN	4046356641937
Weight per Piece (excluding packing)	194.200 g
Custom tariff number	85176200
Country of origin	Germany

Technical data

Note

Utilization restriction	EMC: class A product, see manufacturer's declaration in the download area
-------------------------	---

Dimensions

Width	22.5 mm
Height	99 mm
Depth	114.5 mm

Ambient conditions

Ambient temperature (operation)	-25 °C ... 50 °C
Ambient temperature (storage/transport)	-35 °C ... 80 °C
Degree of protection	IP20

Device supply

Rated control circuit supply voltage U_S	24 V DC -20 % ... +25 %
Rated control supply current I_S	85 mA (plus load current of the outputs)

Data interface - EM-ETH-GATEWAY-IFS - 2901988

Technical data

Device supply

Protective circuit	Reverse polarity protection
	Surge protection

Digital inputs

Number	8
Rated actuating voltage U_c	24 V DC $\pm 20\%$
Rated actuating current I_c	3 mA
Protective circuit	Reverse polarity protection

Digital outputs

Designation	Switching outputs
Number	4
Note on protection circuit	Fusing with max. 8 A F-fuse
Residual voltage	1 V
Maximum switching voltage	23 V DC ($U_B - U_{resid.}$ of the output)
Max. switching current	500 mA
Protective circuit	Parallel protection against polarity reversal, pay attention to the fuse

General

Operating mode	100% operating factor
Mounting position	any
Assembly instructions	In rows with zero spacing
Mounting type	DIN rail mounting
Housing material	Polyamide PA non-reinforced
Color	gray

Serial interface

Interface 1	Interface-System
Serial transmission speed	76.8 kbps
Connection method	DIN rail bus connectors
Interface 2	EtherNet/IP™
Serial transmission speed	100 Mbps
Connection method	RJ45 socket

Connection data

Connection name	Supply
Connection method	Screw connection
Stripping length	8 mm
Screw thread	M3
Conductor cross section solid	0.2 mm ² ... 2 mm ²
Conductor cross section flexible	0.2 mm ² ... 2.5 mm ²
Conductor cross section AWG	24 ... 12

Connection data 2

Data interface - EM-ETH-GATEWAY-IFS - 2901988

Technical data

Connection data 2

Connection name	Programming connection
Connection method	S-PORT (socket)
Number of connections	1
Number of positions	12

Connection data 3

Connection name	INTERFACE system
Connection method	DIN rail bus connectors
Number of connections	1
Number of positions	5

Connection data 4

Connection name	Ethernet/IP™
Connection method	RJ45
Number of connections	1

Standards and Regulations

Standards/regulations	EN 50178
Pollution degree	2
Overvoltage category	III

Environmental Product Compliance

REACH SVHC	Lead 7439-92-1
China RoHS	Environmentally Friendly Use Period = 50
	For details about hazardous substances go to tab "Downloads", Category "Manufacturer's declaration"

Drawings

Data interface - EM-ETH-GATEWAY-IFS - 2901988

Block diagram

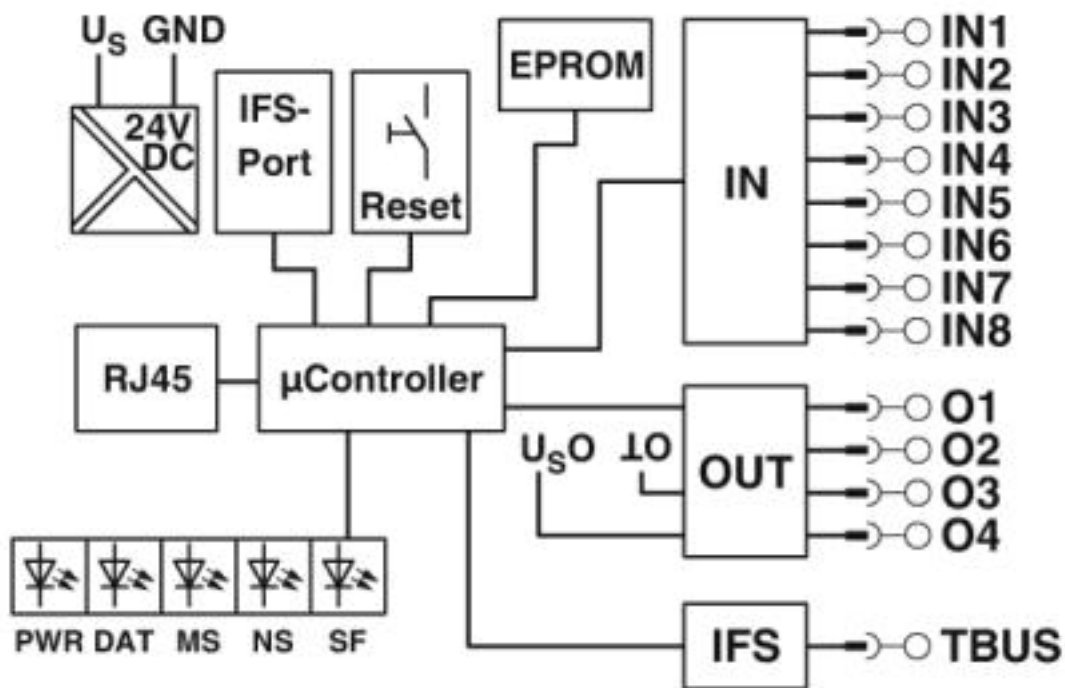

Classifications

eCl@ss

eCl@ss 4.0	27371100
eCl@ss 4.1	27371100
eCl@ss 5.0	27371000
eCl@ss 5.1	27371000
eCl@ss 6.0	27242600
eCl@ss 7.0	27242608
eCl@ss 8.0	27242608
eCl@ss 9.0	27242608

ETIM

ETIM 3.0	EC001604
ETIM 4.0	EC001604
ETIM 5.0	EC001604
ETIM 6.0	EC001604
ETIM 7.0	EC001604

UNSPSC

UNSPSC 6.01	30211915
UNSPSC 7.0901	39121514
UNSPSC 11	39121514



Data interface - EM-ETH-GATEWAY-IFS - 2901988

Classifications

UNSPSC

UNSPSC 12.01	39121514
UNSPSC 13.2	32151602

Approvals

Approvals

Approvals

UL Listed / cUL Listed / EAC / cULus Listed

Ex Approvals

Approval details

UL Listed		http://database.ul.com/cgi-bin/XYV/template/LISEXT/1FRAME/index.htm	FILE E 140324
-----------	---	---	---------------

cUL Listed		http://database.ul.com/cgi-bin/XYV/template/LISEXT/1FRAME/index.htm	FILE E 140324
------------	---	---	---------------

EAC			RU C- DE.A*30.B.01082
-----	---	--	--------------------------

cULus Listed			
--------------	---	--	--



SCATTERGOOD & JOHNSON LTD

ELECTRICAL ENGINEERING & FLUID CONTROL DISTRIBUTORS

Est.1899

At Scattergood & Johnson Ltd, we pride ourselves on being a technical distributor to specialist industries.

Working with a range of quality product suppliers across a number of specialist markets, we are not your average 'box shifter' - we are your technical and supply chain partner.

We fully support every product we sell - for free! Our internal team and external sales engineers can answer any product or application question, no matter the complexity.

Backing up this technical ability is a range of 50,000+ products available from stock for nationwide next day delivery (same day if required!), or you can collect what you need from any of our trade counters around the UK.

Select your specialist interest below to learn more about how we can help.



Online, In Branch and On the Road - Scattergood & Johnson Ltd, there when you need us.

www.scatts.co.uk