

# EMD-BL-C-10(-PT)

**Electronic monitoring relay for overcurrent and undercurrent monitoring of alternating current in single-phase networks**



Data sheet  
105670\_en\_01

© PHOENIX CONTACT - 2016-05-03

## 1 Description

Safety and system availability requirements are constantly on the increase – across all industries. Processes are becoming more and more complex, not only in machine building and the chemical industry but also in building technology. The demands placed on energy technology are also constantly on the rise.

It is only by continuously monitoring key network and system parameters that error-free and therefore cost-effective operation can be achieved. Electronic monitoring relays from the EMD series are available for a wide range of monitoring tasks so that the consequences of errors can be avoided or kept within limits.

The operating states are signaled via color LEDs and any errors that occur can be sent to a controller via a floating contact or can shut down a section of the system. All device versions are equipped with response delays so that measured values outside the set monitoring range can be briefly tolerated.

## Features

- Over/undercurrent monitoring
- Window function
- Adjustable threshold values
- Adjustable response delay
- Two adjustable monitoring ranges up to 5 A/10 A
- One PDT



**WARNING: Risk of electric shock**

Never carry out work when voltage is present.



Make sure you always use the latest documentation.

It can be downloaded from the product at [phoenixcontact.net/products](http://phoenixcontact.net/products).

## 2 Ordering data

Description	Type	Order No.	Pcs./Pkt.
Electronic monitoring relay for overcurrent and undercurrent monitoring of alternating current in single-phase networks	EMD-BL-C-10-PT	2903522	1
Electronic monitoring relay for overcurrent and undercurrent monitoring of alternating current in single-phase networks	EMD-BL-C-10	2903521	1

## 3 Technical data

Input data	
Input name	Measuring input
Measured value	AC sine (48 Hz ... 63 Hz)
Input current range	0 A ... 5 A 0 A ... 10 A Configurable via rotary switches
Overload capacity	13 A AC
Input resistance current input	3 mΩ
Min. setting range	5 % ... 95 % (From I <sub>N</sub> )
Max. setting range	10 % ... 100 % (From I <sub>N</sub> )
Maximum temperature coefficient	≤ 0.05 %
Setting range for response delay	0.1 s ... 10 s
Function	Overcurrent, undercurrent, window
Basic accuracy	≤ 5 % (of the nominal value)
Setting accuracy	± 5 % (of the nominal value)
Repeat accuracy	≤ 2 %
Recovery time	> 500 ms
Output data	
Contact type	1 floating PDT
Maximum switching voltage	250 V AC (in acc. with IEC 60664-1)
Interrupting rating (ohmic load) max.	1250 VA (5 A/250 V AC)
Output fuse	5 A (fast-blow)
Supply	
Supply voltage	230 V AC ±15 %
Frequency range	48 Hz ... 63 Hz
Nominal power consumption	5 VA (0.8 W)

General data		
Mains type	1-phase	
Operating voltage display	Green LED	
Status display	Yellow LED	
Indication	Red LED	
Mechanical service life	15 x 10 <sup>6</sup> cycles	
Service life, electrical	1 x 10 <sup>5</sup> cycles	
Switching frequency	≤ 6 (per minute at 1250 VA ohmic load)	
Operating mode	100% operating factor	
Degree of protection	IP40 (housing) / IP20 (connection terminal blocks)	
Degree of pollution	2 (DIN EN 60947-5-1)	
Overvoltage category	III, 300 V basic insulation (DIN EN 60947-5-1)	
Rated insulation voltage	300 V (Supply circuit (DIN EN 60947-5-1))	
Mounting	on standard DIN rail NS 35 in accordance with EN 60715	
Mounting position	any	
Width	17.5 mm	
Height	88 mm	
Depth	65.5 mm	
Type of housing	Polyamide PA66, self-extinguishing	
Color	gray	
Connection data	Push-in connection	Screw connection
Conductor cross section, solid	0.14 mm <sup>2</sup> ... 2.5 mm <sup>2</sup>	0.5 mm <sup>2</sup> ... 2.5 mm <sup>2</sup>
Conductor cross section, flexible	0.14 mm <sup>2</sup> ... 2.5 mm <sup>2</sup>	0.5 mm <sup>2</sup> ... 2.5 mm <sup>2</sup>
AWG	26 ... 14	20 ... 14
Stripping length	8 mm	8 mm
Tightening torque		1 Nm
Ambient conditions		
Ambient temperature (operation)	-25 °C ... 55 °C	
Ambient temperature (storage/transport)	-25 °C ... 70 °C	
Permissible humidity (operation)	15 % ... 85 %	
Climatic class	3K3 (in acc. with EN 60721)	
Conformance / approvals		
Conformance	CE-compliant	
UL, USA / Canada	 ENEC	
UL, USA / Canada	UL/C-UL listed UL 508	
Conformance with EMC Directive 2004/108/EC (valid until April 19, 2016) / 2014/30/EU (valid from April 20, 2016)		
Noise immunity according to	EN 61000-6-2	
Noise emission according to	EN 61000-6-3	
Conformance with Low Voltage Directive 2006/95/EC (valid until April 19, 2016) / 2014/35/EU (valid from April 20, 2016)		
Low voltage switchgear according to	EN 60947-5-1	

## 4 Block diagram

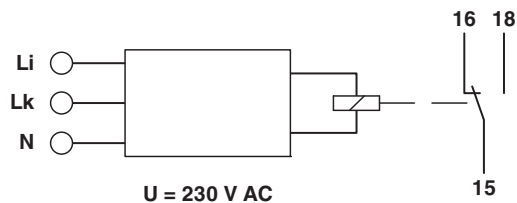

## 5 Safety notes



**WARNING: Risk of electric shock**

Never carry out work when voltage is present.

## 6 Structure

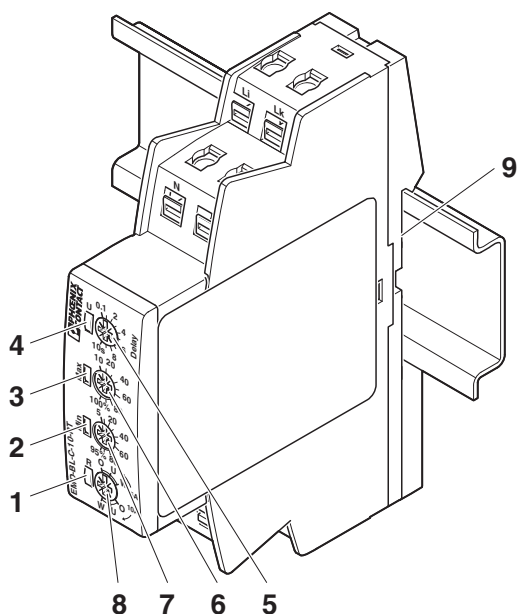

- 1 LED: output relay R
- 2 LED: minimum threshold value (Min)
- 3 LED: maximum threshold value (Max)
- 4 LED: supply U
- 5 "DELAY" potentiometer: Response delay
- 6 "MAX" potentiometer: Upper threshold value
- 7 "MIN" potentiometer: Lower threshold value
- 8 Rotary switch for function selection
- 9 Snap-on foot for DIN rail mounting

## 7 Installation



**WARNING: Risk of electric shock**

Never carry out work when voltage is present.

The module can be snapped onto all 35 mm DIN rails according to EN 60715.

Supply voltage in the range of 230 V AC  $\pm 15\%$

## 8 Diagnostics

The LEDs indicate the following error states:

### "U" LED (Green)

- LED ON: Supply voltage present

### "MIN" and "MAX" LEDs (Red)

- LED flashing: indicates response delay for the corresponding threshold
- LED ON: indicates error for the corresponding threshold

### "R" LED (yellow)

- LED ON: Output relay has picked up
- LED OFF: Output relay has dropped out

## 9 Connection examples

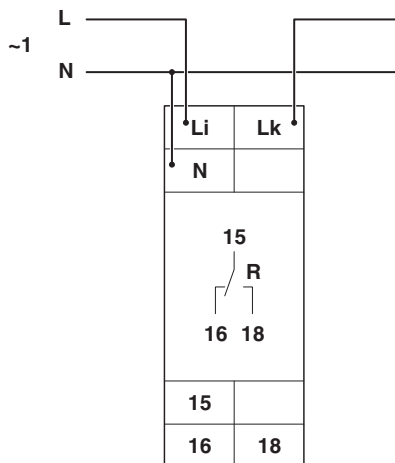

## 10 Function

The "FUNCTION" rotary switch is used to set the desired function:

- O = Overcurrent monitoring (OVER)
- U = Undercurrent monitoring (UNDER)
- W = Monitoring of the area between thresholds MIN and MAX (window function) (WIN)

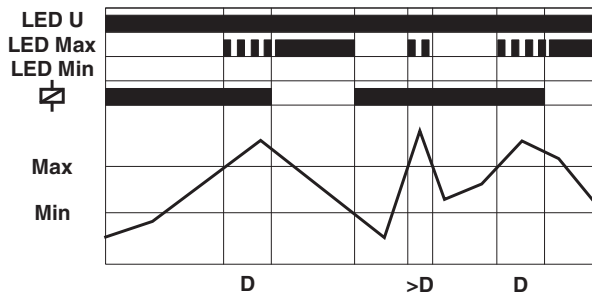

### Overcurrent Monitoring (OVER)

If the measured current exceeds the value set at the “MAX” controller, the set response delay ( $D = \text{DELAY}$ ) starts (red “MAX” LED flashes).

After the delay time has elapsed (red “MAX” LED is ON), output relay “R” drops out (yellow “R” LED is OFF). If the measured current falls below the value set at the “MIN” controller (red “MAX” LED is OFF), output relay “R” picks up again (yellow “R” LED is ON).

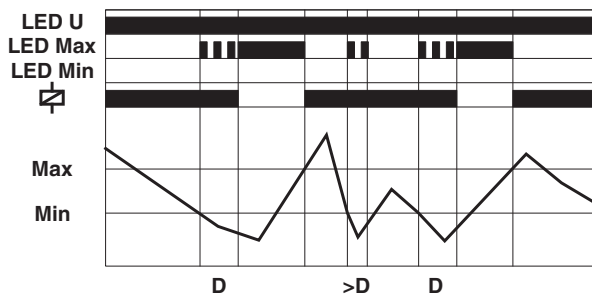

### Undercurrent Monitoring (UNDER)

If the measured current falls below the value set at the “MIN” controller, the set response delay ( $D = \text{DELAY}$ ) starts (red “MIN” LED flashes). After the delay time has elapsed (red “MIN” LED is ON), output relay “R” drops out (yellow “R” LED is OFF).

If the measured current exceeds the value set at the “MAX” controller, output relay “R” picks up again (yellow “R” LED is ON).

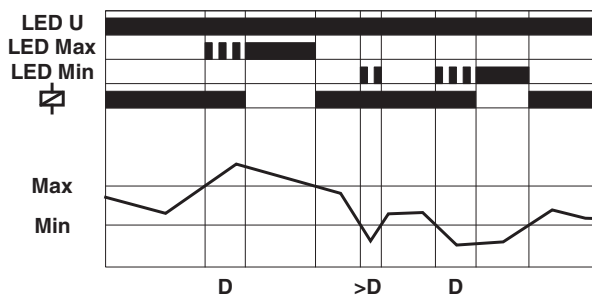

### Window Function (WIN)

Output relay “R” picks up (yellow “R” LED is ON) if the measured current exceeds the value set at the “MIN” controller. If the measured current exceeds the value set at the “MAX” controller, the set response delay ( $D = \text{DELAY}$ ) starts (red “MAX” LED flashes). After the delay time has elapsed (red “MAX” LED is ON), output relay “R” drops out (yellow “R” LED is OFF).

Output relay “R” picks up again (yellow “R” LED is ON) if the measured current falls below the maximum value again (red “MAX” LED is OFF). If the measured current falls below the value set at the “MIN” controller, the set response delay ( $D = \text{DELAY}$ ) starts (red “MIN” LED flashes). After the delay time has elapsed (red “MIN” LED is ON), output relay “R” drops out (yellow “R” LED is OFF).



# SCATTERGOOD & JOHNSON LTD

ELECTRICAL ENGINEERING & FLUID CONTROL DISTRIBUTORS

Est.1899

At Scattergood & Johnson Ltd, we pride ourselves on being a technical distributor to specialist industries.

Working with a range of quality product suppliers across a number of specialist markets, we are not your average 'box shifter' - we are your technical and supply chain partner.

We fully support every product we sell - for free! Our internal team and external sales engineers can answer any product or application question, no matter the complexity.

Backing up this technical ability is a range of 50,000+ products available from stock for nationwide next day delivery (same day if required!), or you can collect what you need from any of our trade counters around the UK.

Select your specialist interest below to learn more about how we can help.



Online, In Branch and On the Road - Scattergood & Johnson Ltd, there when you need us.

# [www.scatts.co.uk](http://www.scatts.co.uk)