

EMD-BL-PH-480(-PT)

Electronic monitoring relay for phase sequence, phase failure, and asymmetry monitoring



Data sheet
105673_en_01

© PHOENIX CONTACT - 2016-05-03

1 Description

Safety and system availability requirements are constantly on the increase – across all industries. Processes are becoming more and more complex, not only in machine building and the chemical industry but also in building technology. The demands placed on energy technology are also constantly on the rise.

It is only by continuously monitoring key network and system parameters that error-free and therefore cost-effective operation can be achieved. Electronic monitoring relays from the EMD series are available for a wide range of monitoring tasks so that the consequences of errors can be avoided or kept within limits.

The operating states are signaled via color LEDs and any errors that occur can be sent to a controller via a floating contact or can shut down a section of the system. All device versions are equipped with response delays so that measured values outside the set monitoring range can be briefly tolerated.

Features

- Phase sequence monitoring
- Phase failure monitoring
- Asymmetry monitoring, can be enabled and adjusted



WARNING: Risk of electric shock

Never carry out work when voltage is present.



Make sure you always use the latest documentation.

It can be downloaded from the product at phoenixcontact.net/products.

2 Ordering data

Description	Type	Order No.	Pcs./Pkt.
Electronic monitoring relay for phase sequence, phase failure, and asymmetry monitoring	EMD-BL-PH-480-PT	2903528	1
Electronic monitoring relay for phase sequence, phase failure, and asymmetry monitoring	EMD-BL-PH-480	2903527	1

3 Technical data

Input data

Input name	Measuring input
Measured value	AC sine (48 Hz ... 63 Hz)
Nominal input voltage U_N	480 V (3~ 208 ... 480 V/120 ... 277 V)
Setting range for response delay	0.1 s ... 10 s
Min setting range of the voltage threshold value	187 V AC
Max. setting range of the voltage threshold value	519 V AC
Function	Phase sequence, phase failure, asymmetry
Basic accuracy	$\leq 5\%$ (of scale end value)
Setting accuracy	$\pm 5\%$ (of scale end value)
Repeat accuracy	$\leq 2\%$
Asymmetry	5 % ... 25% / OFF
Recovery time	> 500 ms

Output data

Contact type	1 floating PDT
Maximum switching voltage	250 V AC (in acc. with IEC 60664-1)
Interrupting rating (ohmic load) max.	1250 VA (5 A/250 V AC)
Output fuse	5 A (fast-blow)

Supply

Supply voltage	$\pm 10\%$ (= measuring voltage)
Frequency range	48 Hz ... 63 Hz
Nominal power consumption	10 VA ((1 W) at 400 V/50 Hz)

General data

Mains type	3-phase
Operating voltage display	Green LED
Status display	Yellow LED
Indication	Red LED
Mechanical service life	15 x 10 ⁶ cycles
Service life, electrical	1 x 10 ⁵ cycles
Switching frequency	≤ 6 (per minute at 1250 VA ohmic load)
Operating mode	100% operating factor
Degree of protection	IP40 (housing) / IP20 (connection terminal blocks)
Degree of pollution	2 (DIN EN 60947-5-1)
Overvoltage category	III, 300 V basic insulation (DIN EN 60947-5-1)
Rated insulation voltage	519 V (Supply circuit/measuring circuit (DIN EN 60947-5-1))
Mounting	on standard DIN rail NS 35 in accordance with EN 60715
Mounting position	any
Width	17.5 mm
Height	88 mm
Depth	65.5 mm
Type of housing	Polyamide PA66, self-extinguishing
Color	gray

Connection data	Push-in connection	Screw connection
Conductor cross section, solid	0.14 mm ² ... 2.5 mm ²	0.5 mm ² ... 2.5 mm ²
Conductor cross section, flexible	0.14 mm ² ... 2.5 mm ²	0.5 mm ² ... 2.5 mm ²
AWG	26 ... 14	20 ... 14
Stripping length	8 mm	8 mm
Tightening torque		1 Nm

Ambient conditions

Ambient temperature (operation)	-25 °C ... 55 °C
Ambient temperature (storage/transport)	-25 °C ... 70 °C
Permissible humidity (operation)	15 % ... 85 %
Climatic class	3K3 (in acc. with EN 60721)

Conformance / approvals

Conformance	CE-compliant
UL, USA / Canada	 ENEC
UL, USA / Canada	UL/C-UL listed UL 508

Conformance with EMC Directive 2004/108/EC (valid until April 19, 2016) / 2014/30/EU (valid from April 20, 2016)

Noise immunity according to	EN 61000-6-2
Noise emission according to	EN 61000-6-3

Conformance with Low Voltage Directive 2006/95/EC (valid until April 19, 2016) / 2014/35/EU (valid from April 20, 2016)

Low voltage switchgear according to	EN 60947-5-1
-------------------------------------	--------------

4 Block diagram

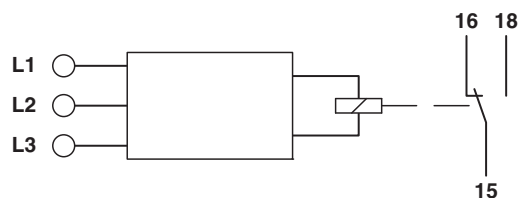

5 Safety notes



WARNING: Risk of electric shock

Never carry out work when voltage is present.

6 Structure

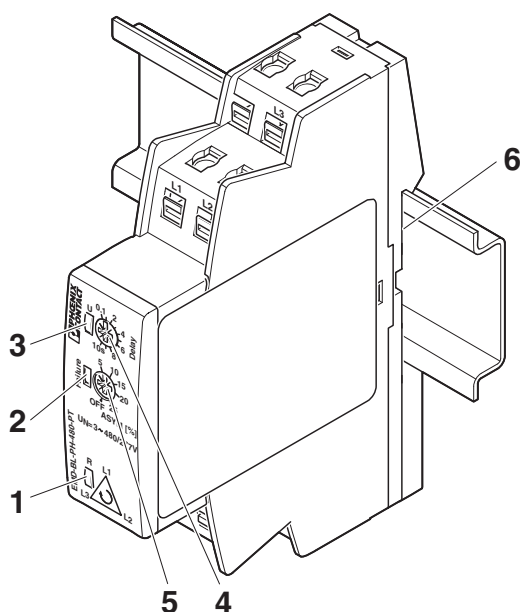

- 1 LED: output relay R
- 2 LED: failure
- 3 LED: supply U
- 4 "DELAY" potentiometer: Response delay
- 5 "ASYM" potentiometer: Asymmetry
- 6 Snap-on foot for DIN rail mounting

7 Installation



WARNING: Risk of electric shock

Never carry out work when voltage is present.

The module can be snapped onto all 35 mm DIN rails according to EN 60715.

8 Diagnostics

The LEDs indicate the following error states:

"U" LED (Green)

- LED ON: Supply voltage present

"Failure" LED (red):

- LED ON: indicates error
- LED flashing: indicates response delay

"R" LED (yellow)

- LED ON: Output relay has picked up
- LED OFF: Output relay has dropped out

9 Connection examples

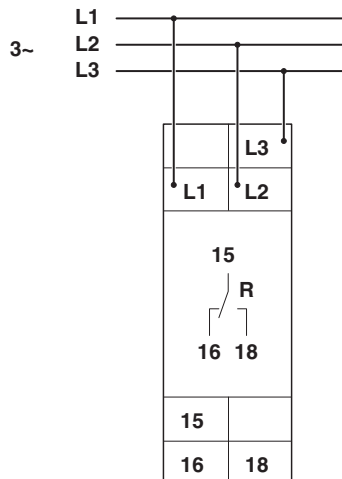

10 Function

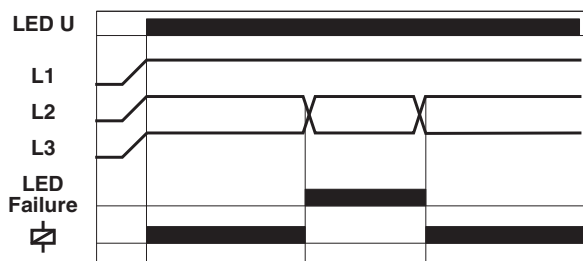

Phase sequence monitoring

If all the phases are connected in the correct order and voltage asymmetry is smaller than the value set, output relay "R" picks up (yellow LED is ON). If the direction of rotation of the phase sequence changes, output relay "R" drops out without delay (yellow LED is OFF).

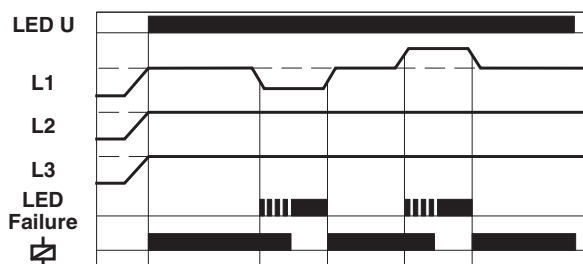

Asymmetry monitoring

If the asymmetry exceeds the value set at the ASYM controller, the response delay starts (red Failure LED flashes). After the time delay has elapsed (red Failure LED is ON), output relay "R" drops out (yellow LED is OFF).

Shutdown is also performed if asymmetry results from reverse voltages of motors running on two phases.



Phase failure monitoring

As soon as one of the phase voltages fails, output relay "R" drops out (red Failure LED is ON / yellow LED is OFF).



SCATTERGOOD & JOHNSON LTD

ELECTRICAL ENGINEERING & FLUID CONTROL DISTRIBUTORS

Est.1899

At Scattergood & Johnson Ltd, we pride ourselves on being a technical distributor to specialist industries.

Working with a range of quality product suppliers across a number of specialist markets, we are not your average 'box shifter' - we are your technical and supply chain partner.

We fully support every product we sell - for free! Our internal team and external sales engineers can answer any product or application question, no matter the complexity.

Backing up this technical ability is a range of 50,000+ products available from stock for nationwide next day delivery (same day if required!), or you can collect what you need from any of our trade counters around the UK.

Select your specialist interest below to learn more about how we can help.



Online, In Branch and On the Road - Scattergood & Johnson Ltd, there when you need us.

www.scatts.co.uk