

EM-PNET-GATEWAY-IFS and ELR H5-IES-SC/500AC-3-IFS

Example application

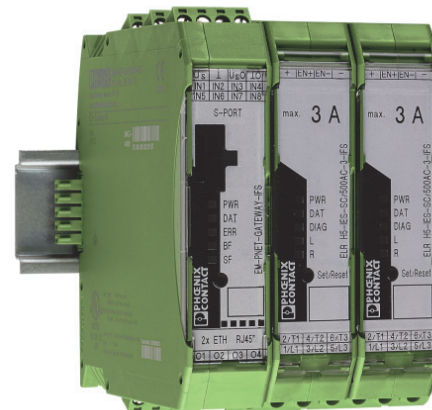

Application note
107440_en_00

© PHOENIX CONTACT 2016-11-04

1 Description

This documentation uses an example application to provide an overview of how you can integrate the EM-PNET-GATEWAY-IFS into the automation environments of Phoenix Contact (PC Worx) and Siemens (SIMATIC Manager).

The necessary device description files and the FDT frame application can be downloaded from the Phoenix Contact homepage. The example application consists of the hardware and software components described (see “Requirements” on page 3).

The aim of the example application is to address the hybrid motor starters via the higher-level controller and to transfer the hybrid motor starter data, such as “Module state”, “Current”, “Error”, and so on, to the controller.



Make sure you always use the latest documentation.
It can be downloaded at phoenixcontact.net/products.



This document is valid for all products listed in “Hardware” on page 3.

Table of contents

1	Description.....	1
2	Requirements	3
2.1	Hardware.....	3
2.2	Software	3
3	Mounting.....	4
4	Configuration	4
4.1	Configuration via NetNames+	4
4.1.1	Scanning the network.....	4
4.2	Configuration via IFS-Conf	5
4.2.1	Connecting the programming adapter.....	5
4.2.2	Software installation	7
4.2.3	Software configuration	7
4.2.4	Process data configuration.....	11
4.2.5	Monitoring dialog	14
4.2.6	Settings.....	15
4.2.7	Diagnostics dialog.....	18
4.2.8	Saving the project	18
4.2.9	Device replacement	19
4.3	Configuration via the web server	19
4.3.1	Calling the web server.....	19
4.3.2	Setting up the Interface system station	20
4.3.3	Process data	25
4.3.4	Station.....	25
4.3.5	Device views	28
4.3.6	Device replacement	41
5	PC Worx	41
5.1	Inserting an FDCML in the folder structure	41
5.2	Integrating FDCMLs	41
5.3	Selecting modules.....	42
5.4	PROFINET settings	43
5.5	Process data assignment	43
6	SIMATIC Manager	44
6.1	Integrating GSDMLs.....	44
6.2	Selecting modules.....	44
6.3	Process data assignment	45

EM-PNET-GATEWAY-IFS and ELR H5-IES-SC/500AC-3-IFS**2 Requirements****2.1 Hardware**

Name	Explanation	Order number
EM-PNET-GATEWAY-IFS	Gateway for the connection of up to 32 Interface system devices to a higher-level controller via PROFINET	2904472
ELR H5-IES-SC/500AC-3-IFS	Networkable hybrid motor starter for reversing 3~ AC motors up to 500 V AC and 3 A output current	2905152
ME 22,5 TBUS 1,5/5-ST-3,81 GN	DIN rail connector for connection to electronics housings	2707437
IFS-USB-DATACABLE	Used for communication between an industrial PC and Phoenix Contact devices with 12-pos. IFS data port	2320500

2.2 Software

Name	Explanation	Version
GSDML_EM-PNET-GATEWAY-IFS_20150923	Device description file	20150923
FDCML_EM-PNET-GATEWAY-IFS	Device description file for PC Worx	01
IFS-CONF-SUITE-INTERFACE	FDT frame application with Interface system DTMs, Interface Analog DTMs, and USB driver	1.22
PC Worx	Automation environment	6.30.1202
SIMATIC Manager	Automation environment	5.5 SP3
NetNames+	Network topology scan	1.50.1202

3 Mounting

The modules must be connected together via the rear panel using the DIN rail connector.

1. Mount the ME 22,5 TBUS 1,5/5-ST-3,81 GN DIN rail connector on the DIN rail.
2. Swivel the devices to attach them.

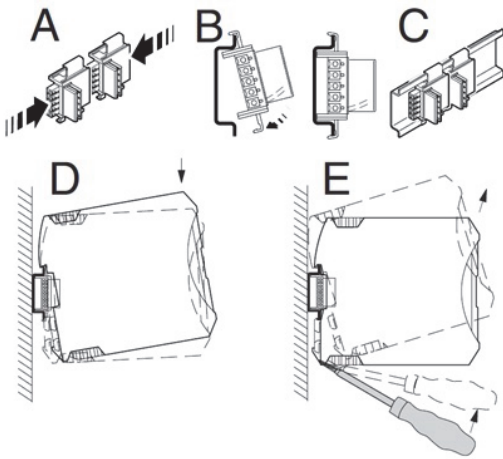

Figure 1 Mounting

4 Configuration

The following options are available for creating an Interface system station:

- Via NetNames+
- Via IFS-Conf
- Via web server

4.1 Configuration via NetNames+

You can use the NetNames+ program to scan the network topology. You can change and view the parameters of the network devices.

In order to use the program, you must connect the “EM-PNET-GATEWAY-IFS” module to the computer via a network cable.



You may also use appropriate programs from other manufacturers to scan the network topology.

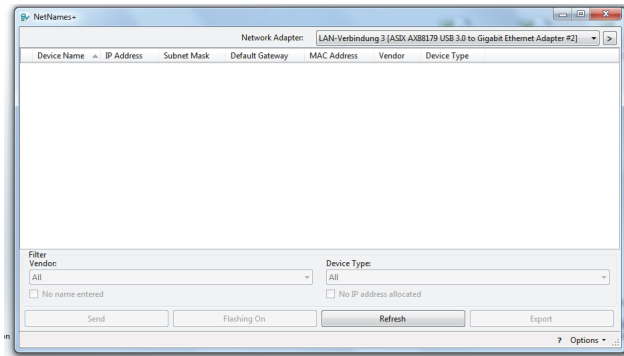

Figure 2 NetNames+ user interface

4.1.1 Scanning the network

1. To scan the network, select the relevant network adapter.

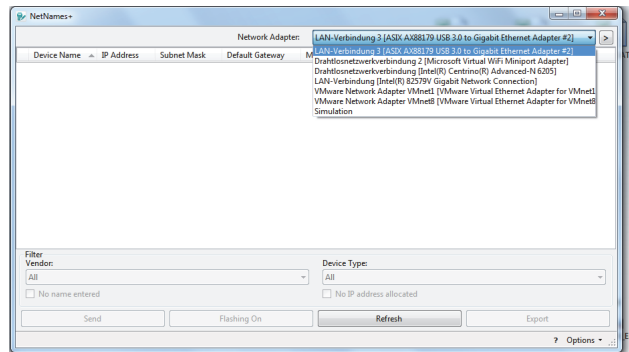

Figure 3 Selecting the network adapter

2. To display all connected network devices, you must scan the network using the “Refresh” button. For a better overview, you can filter by vendor or device type, for example.

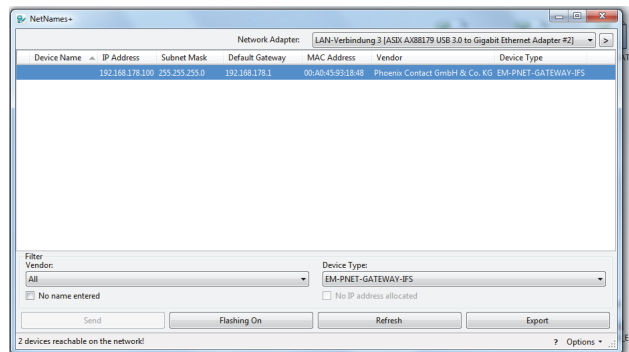

Figure 4 Filtered network topology

Changing parameters

If the search for reachable network devices was successful, you can change and view the following parameters.

Parameter	Default value	Function
Device name	–	Can be changed
IP address	192.168.178.100	Can be changed
Subnet mask	255.255.255.0	Can be changed
Default gateway	192.168.178.1	Can be changed
MAC address	Device-specific	Cannot be changed
Vendor	Phoenix Contact GmbH & Co. KG	Cannot be changed
Device type	EM-PNET-GATEWAY-IFS	Cannot be changed

All parameters that can be changed can be adjusted by double-clicking on the parameter.

1. To forward the changes to the network device, click on the “Send” button.

The IP address can be permanently changed.

1. Under “Options”, activate “Save IP Addresses permanently”.

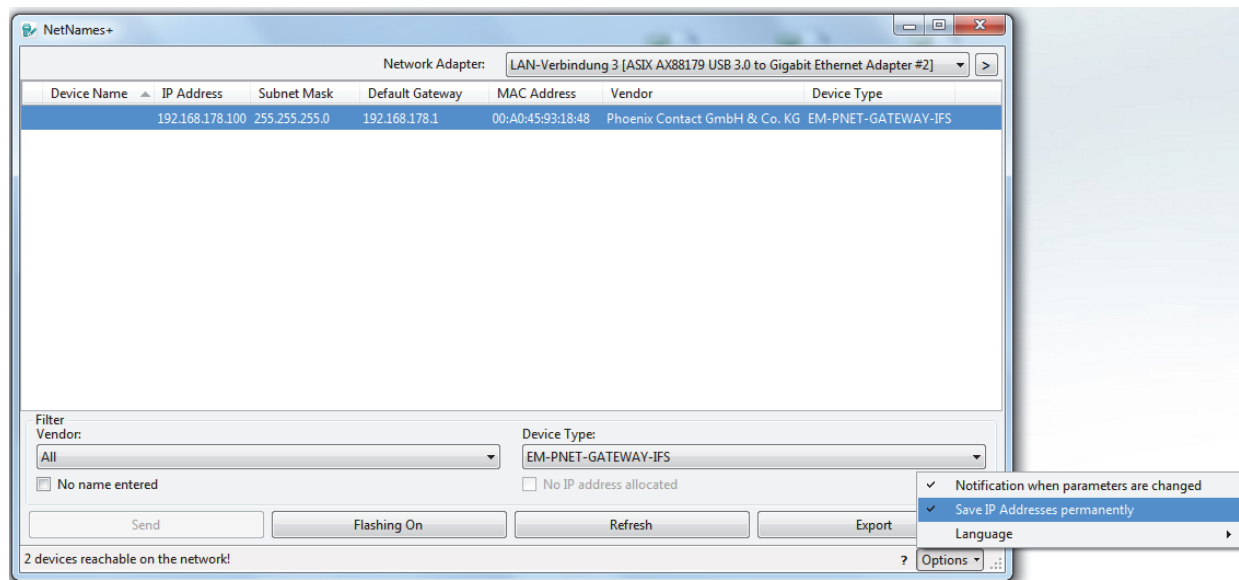

Figure 5 Save IP Addresses permanently

4.2 Configuration via IFS-Conf

4.2.1 Connecting the programming adapter

When configuring Phoenix Contact Interface modules with RJ45 interface, you can use an RJ45 network cable as an alternative.

- IFS-USB-PROG-ADAPTER programming adapter (Order No. 2811271)
- IFS-USB-DATACABLE data cable (Order No. 2320500)
- RJ45 network cable

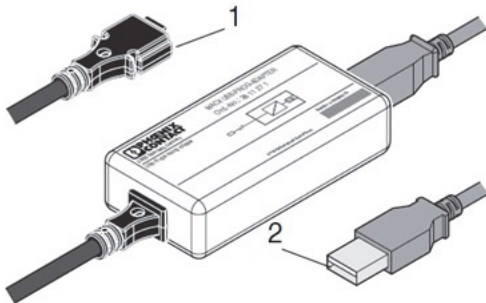

Figure 6 IFS-USB-PROG-ADAPTER

- 1 S-PORT connector
- 2 USB connector

Connection notes



WARNING: Risk of injury

The programming adapter must not be used in potentially explosive areas. Do not use the programming adapter if it is damaged.



The adapter may only be used to program supported Phoenix Contact Interface devices. Check the documentation for your device to see whether the programming adapter is compatible.

You must install the configuration software required for your device prior to initial startup. Refer to the relevant device documentation.

Connection to the PC

Connect the programming adapter to a free USB connection on your PC using the USB cable provided.

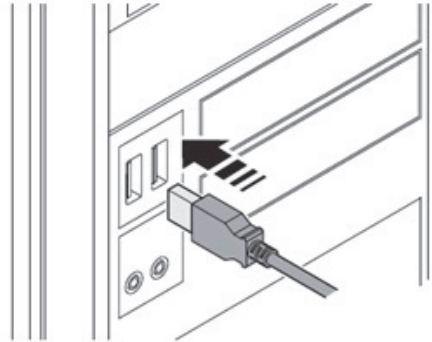

Figure 7 Connection to the PC

Connection to the device

On the device, connect the programming adapter to the 12-pos. S-PORT interface.

Alternatively, you can connect the RJ45 connector of the network cable to one of the Ethernet ports.

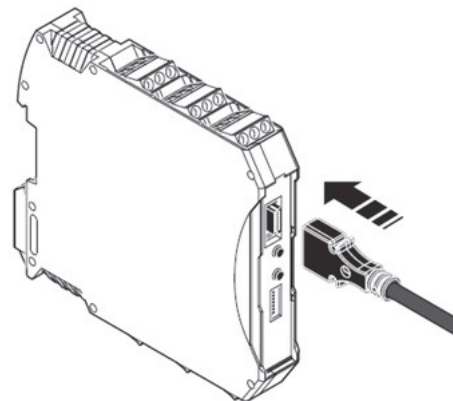

Figure 8 Connection to the device



NOTE: Potential damage to cables

Position the programming adapter so that no strain is placed on the plug-in connection on the device.

If you want to connect 32 EEM devices to a gateway via the DIN rail connector and simultaneously parameterize them, connect the following to the gateway.

- IFS-USB-PROG-ADAPTER (Order No. 2811271)
- IFS-USB-DATACABLE (Order No. 2320500)

4.2.2 Software installation

1. Download the “IFS-CONF-SUITE-INTERFACE Setup” software from phoenixcontact.net/products.
2. Run the installation file by double-clicking on it.



Follow the instructions in the installation program until it comes to selecting the software to be installed.

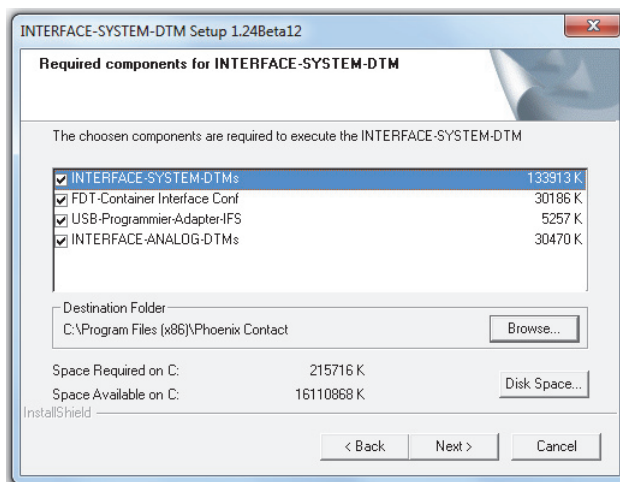

Figure 9 Installation wizard

All options are installed by default.

You must install and use Phoenix Contact's own FDT frame application (FDT container IFS-Conf) for all of the following descriptions.



Only Phoenix Contact DTMs can be integrated into Phoenix Contact's own FDT frame application (FDT container IFS-Conf).

Other available FDT frame applications, such as M&M (see phoenixcontact.net/products), can be used to manage DTMs from various manufacturers.

Starting the application

Start the application by double-clicking on the “IFS-Conf” icon.



Figure 10 “IFS-Conf” software icon

4.2.3 Software configuration

Initial startup

When starting the IFS-Conf application for the first time, you must set up an administrator. Additional users can be set up within the application under “Tools, User Administration”.



Select the “Use Windows login for this user” check box if you wish to log in as standard with this user name each time the application starts.

In this case, you will not be prompted for your password when the application starts, as authentication has already taken place through the Windows login.

This setting is not recommended for an administrator.

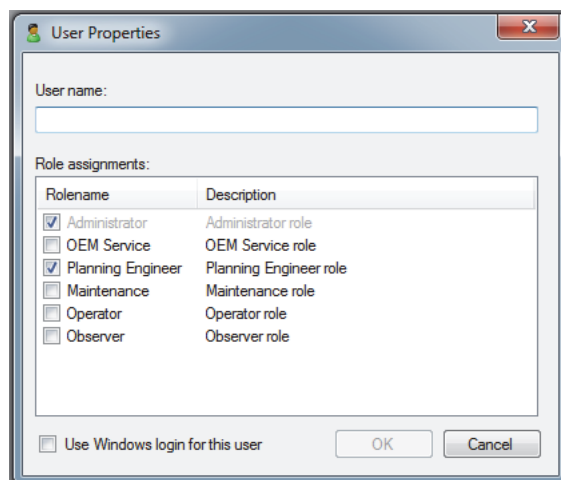

Figure 11 Creating a user when starting the software for the first time

EM-PNET-GATEWAY-IFS and ELR H5-IES-SC/500AC-3-IFS

Transferring CONTACTRON-DTM-IFS to catalog management

If you have created the user, DTM Catalog Management opens automatically.

Select the “Search for installed DTMs” button.

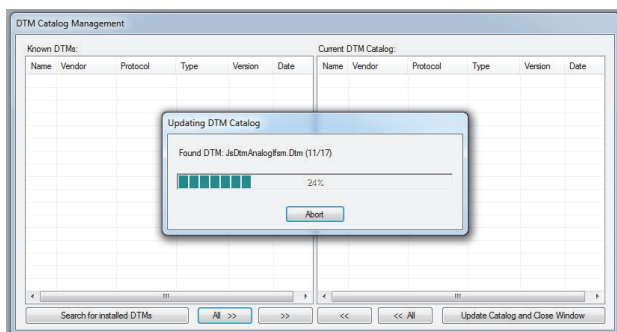

Figure 12 Searching for known DTMs

All DTMs found on the system are then displayed in the left-hand table under “Known DTMs”. Transfer all desired DTMs to the current DTM catalog.

To do this, proceed as follows:

1. Select the DTM or several DTMs simultaneously.
2. Select the “»” button or transfer all the DTMs using the “All »” button.

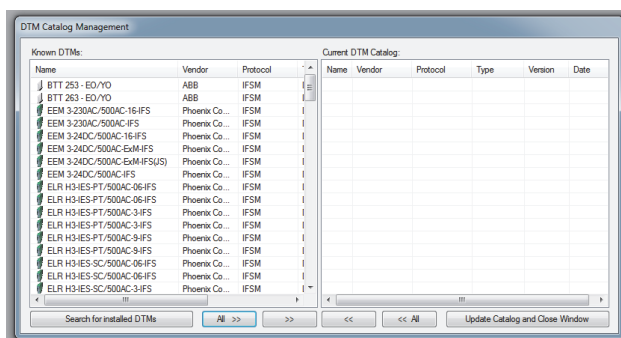

Figure 13 Displaying known DTMs

All desired DTMs are displayed in the current DTM catalog. If you transfer additional DTMs at a later time, follow the same procedure.

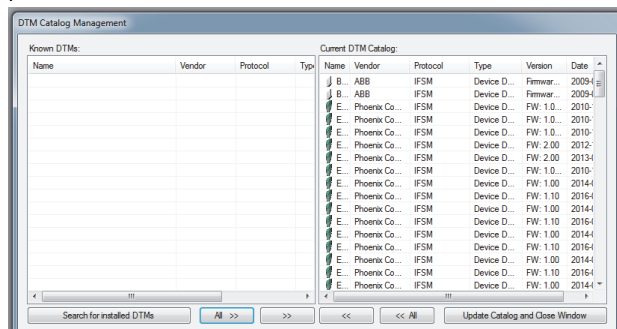

Figure 14 DTM Catalog Management

3. Click on the “Close” button.

Catalog management closes and all DTMs are prepared for further use in the current DTM catalog.

Topology scan

1. Click on the “Scan Topology..., IFSMGwChannel” button to manually start the Topology Scan Wizard and search for connected devices.

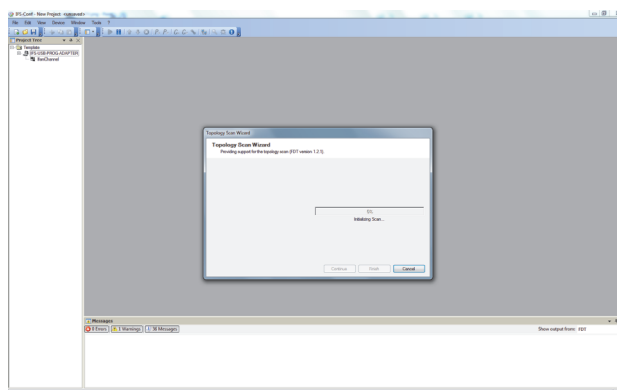

Figure 15 Topology scan

EM-PNET-GATEWAY-IFS and ELR H5-IES-SC/500AC-3-IFS

The device search is in progress.

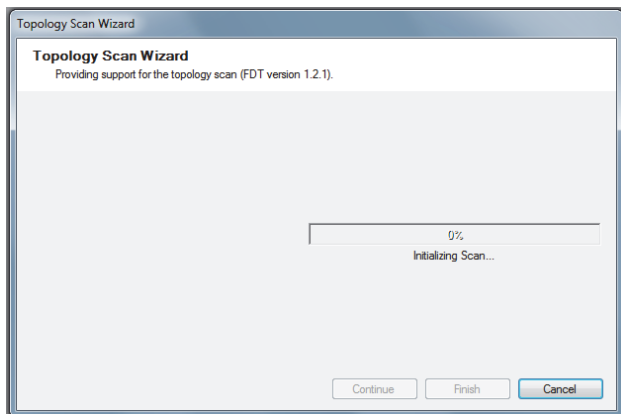

Figure 16 Topology Scan Wizard

Any modules found are displayed in the project tree.

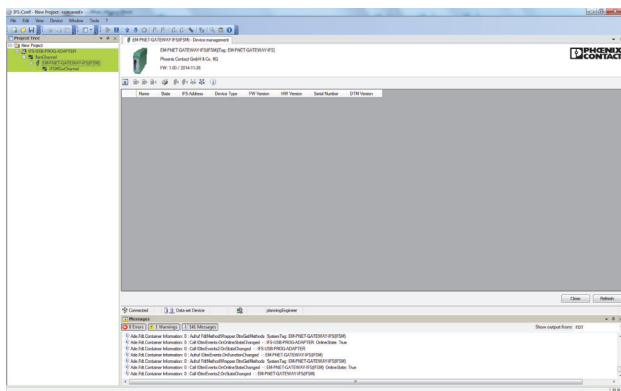

Figure 17 Project tree

If you are using an RJ45 network cable for device configuration, you can cancel the device scan prematurely.

1. Open a new project.
2. Add the IFS-TCP-PROG-ADAPTER to the project tree.

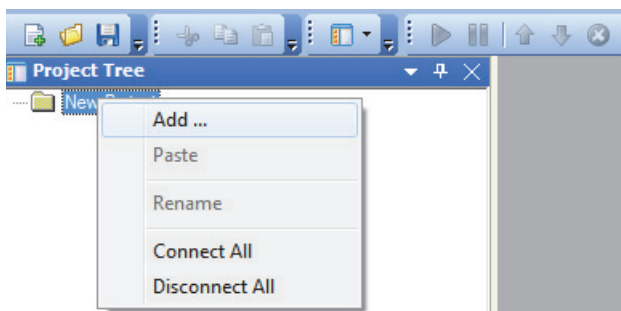

Figure 18 Adding the adapter

3. Select the IFS-TCP-PROG-ADAPTER.

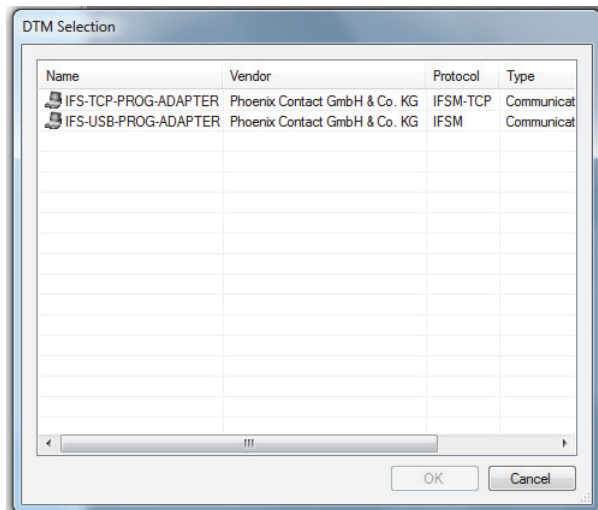

Figure 19 Selecting the adapter

4. To parameterize the adapter, click on the adapter in the project tree.

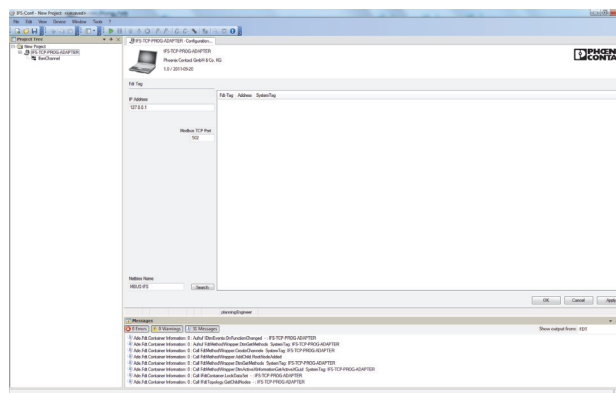

Figure 20 Parameterizing the adapter

5. Enter the IP address of the EM-PNET-GATEWAY-IFS in the "IP Address" input field.
6. Confirm your entry with "Apply".
7. Click on the "OK" button.

Connecting several devices via an IFS gateway

If several devices which do not have a unique IFS address are connected to a gateway via the DIN rail connector, you can cancel the topology scan.

The connected devices are no longer visible in the project tree. Use the device management function. “Device management” on page 10

Functions

You can manage devices connected to the gateway and configure process data via the “Functions” menu item.

1. Open device management on the gateway via the “Functions, Device management” menu item.

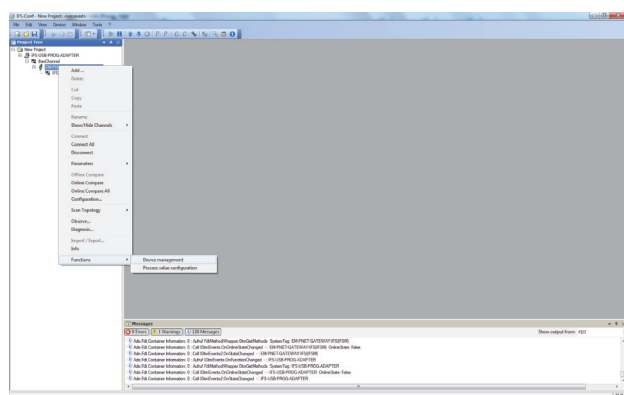

Figure 21 Opening device management

2. Click on the “Connect” button in the toolbar to establish a connection to the gateway.



When successfully connected to the gateway, the button in the project tree appears green.

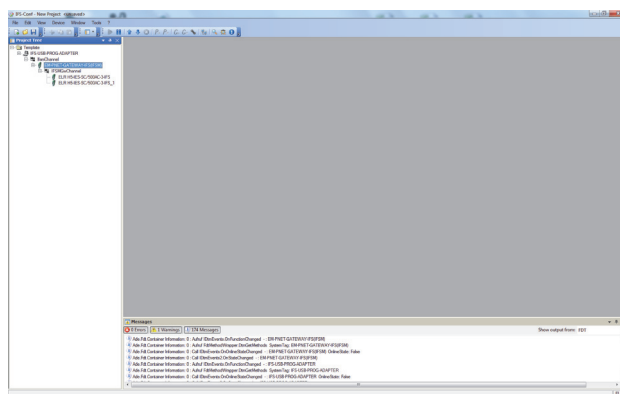

Figure 22 Device management

3. Click on the “Refresh” button to read the hardware structure.

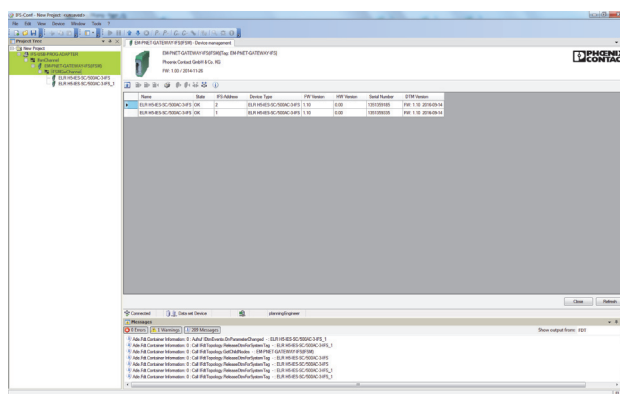

Figure 23 Reading the hardware structure

4. Assign a unique Interface system address to each connected device.
5. Assign a unique name to each device.



If addresses have already been assigned to Interface system bus devices, you just need to change the device names.

Write information to the devices.

6. Right-click on the gateway in the project tree.
7. Select “Parameters, Download All Parameters”.
The devices are highlighted in green.

Definition of process data

You can view and define the process data that can be assigned to each device.

1. Select the device.

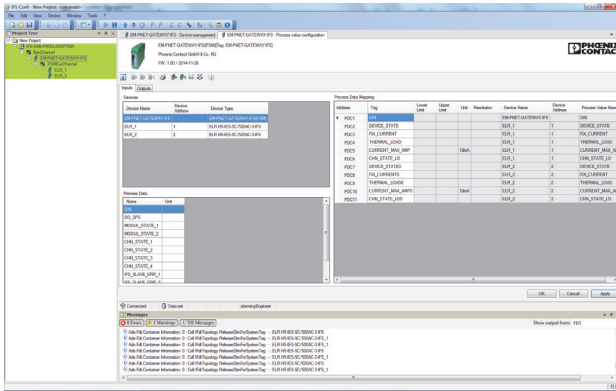

Figure 28 Device selection

2. Select either “Inputs” or “Outputs”.
3. Double-click to select the required process data.
4. Click on the “Apply” button to apply the process data to the project.

EM-PNET-GATEWAY-IFS and ELR H5-IES-SC/500AC-3-IFS

In this example, transfer the following process data to the controller.

Process data item	Communication direction	Description	Interface system device
DIN	Input	Digital inputs of the gateway	EM-PNET-GATEWAY-IFS
DOUT	Output	Digital outputs of the gateway	EM-PNET-GATEWAY-IFS
DEVICE-STATE	Input	Current device status of the hybrid motor starter	ELR H5-IES-SC/500AC-3-IFS_1
FIX_CURRENT	Input	Current set nominal current of the hybrid motor starter	ELR H5-IES-SC/500AC-3-IFS_1
THERMAL_LOAD	Input	Current thermal load of the hybrid motor starter	ELR H5-IES-SC/500AC-3-IFS_1
CURRENT_MAX_AMP	Input	Current maximum current flow of the three phases of the connected electrical machine	ELR H5-IES-SC/500AC-3-IFS_1
CHN_STATE_LO	Input	Coding of the individual possible device messages and warnings	ELR H5-IES-SC/500AC-3-IFS_1
CONTROL_SWITCH	Output	Control word of the hybrid motor starter	ELR H5-IES-SC/500AC-3-IFS_1
SET_FIX_CURRENT	Output	Change nominal current setting of the hybrid motor starter via the bus	ELR H5-IES-SC/500AC-3-IFS_1
DEVICE-STATE	Input	Current device status of the hybrid motor starter	ELR H5-IES-SC/500AC-3-IFS_2
FIX_CURRENT	Input	Current set nominal current of the hybrid motor starter	ELR H5-IES-SC/500AC-3-IFS_2
THERMAL_LOAD	Input	Current thermal load of the hybrid motor starter	ELR H5-IES-SC/500AC-3-IFS_2
CURRENT_MAX_AMP	Input	Current maximum current flow of the three phases of the connected electrical machine	ELR H5-IES-SC/500AC-3-IFS_2
CHN_STATE_LO	Input	Coding of the individual possible device messages and warnings	ELR H5-IES-SC/500AC-3-IFS_2
CONTROL_SWITCH	Output	Control word of the hybrid motor starter	ELR H5-IES-SC/500AC-3-IFS_2
SET_FIX_CURRENT	Output	Change nominal current setting of the hybrid motor starter via the bus	ELR H5-IES-SC/500AC-3-IFS_2

Control

Switch:

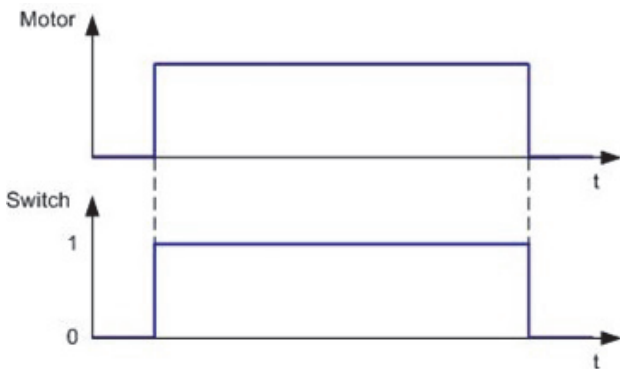

Figure 29 Switching behavior of the switch

Button:

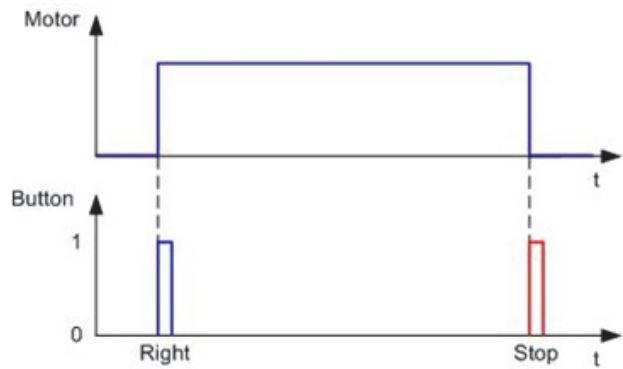

Figure 30 Switching behavior of the button

EM-PNET-GATEWAY-IFS and ELR H5-IES-SC/500AC-3-IFS

Downloading process data

Write the project data to the modules as follows:

1. Right-click on the gateway in the project tree.
2. Select "Parameters, Download All Parameters".

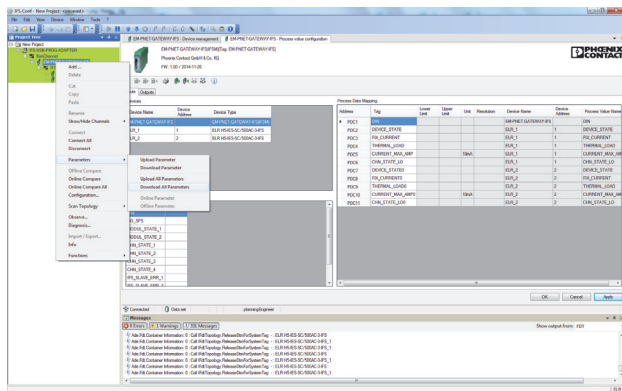

Figure 31 Writing project data to the modules

4.2.5 Monitoring dialog

You can display the cyclically updated process data values of connected Interface system devices via the monitoring dialog.

The data was assigned in the process data configuration. The data is displayed in hexadecimal, binary, and decimal format.

The units of the measured values are also displayed.

1. Right-click on the gateway.
2. Select "Observe".

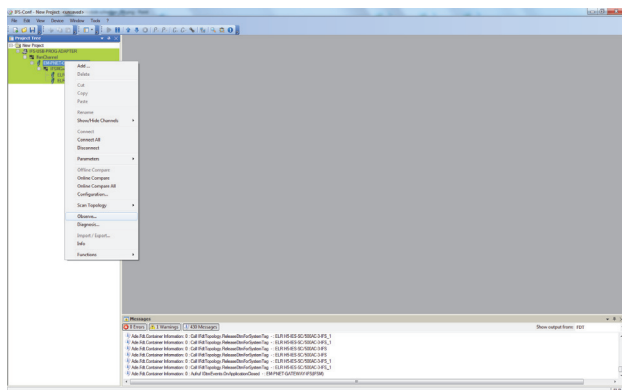

Figure 32 Monitoring

The defined process data is displayed with the corresponding measured values.

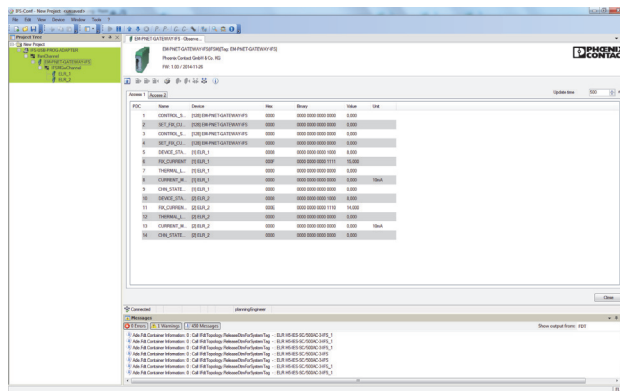

Figure 33 Displaying process values in the "Observe" window

EM-PNET-GATEWAY-IFS and ELR H5-IES-SC/500AC-3-IFS

4.2.6 Settings

Set the gateway properties, such as the IP address.

1. Right-click on the gateway.
2. Select "Configuration".

EM-PNET-GATEWAY-IFS PROFINET gateway

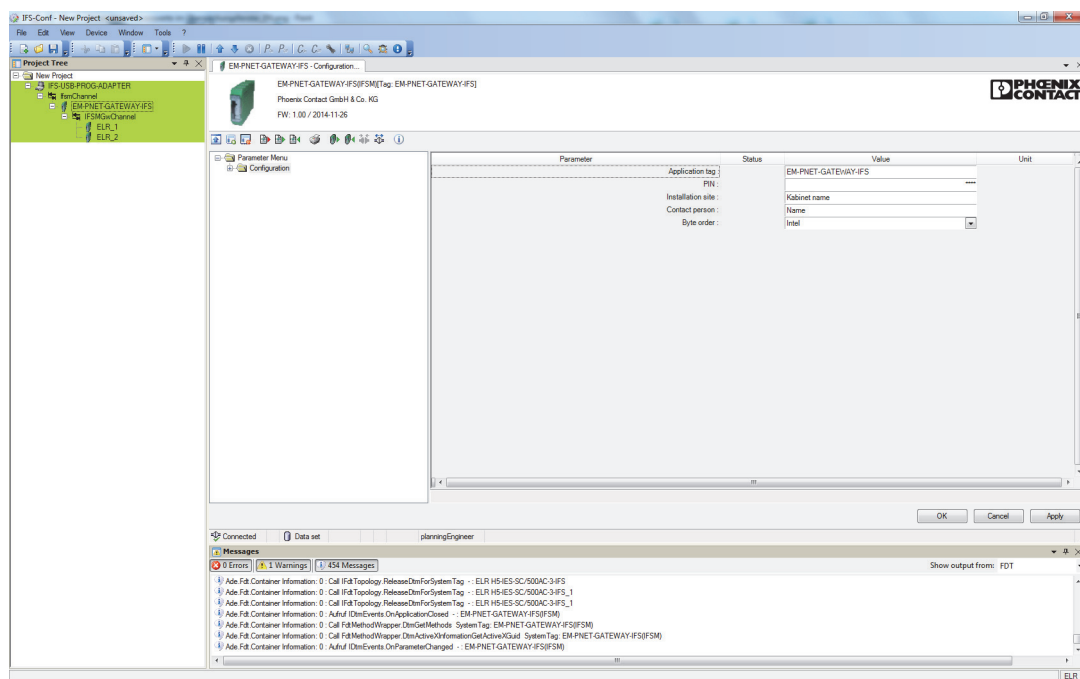

Figure 34 PROFINET gateway settings – configuration

Parameter	Selection	Interval	Program side
Application tag	– Max. 32 characters	-	EM-PNET-GATEWAY-IFS
PIN	– Min: 0	-	0000
	– Max: 9999		
Installation site	– Max. 32 characters	-	Kabinet name
Contact person	– Max. 32 characters	-	Name
Byte order	– Intel	-	Intel
	– Motorola		

EM-PNET-GATEWAY-IFS and ELR H5-IES-SC/500AC-3-IFS

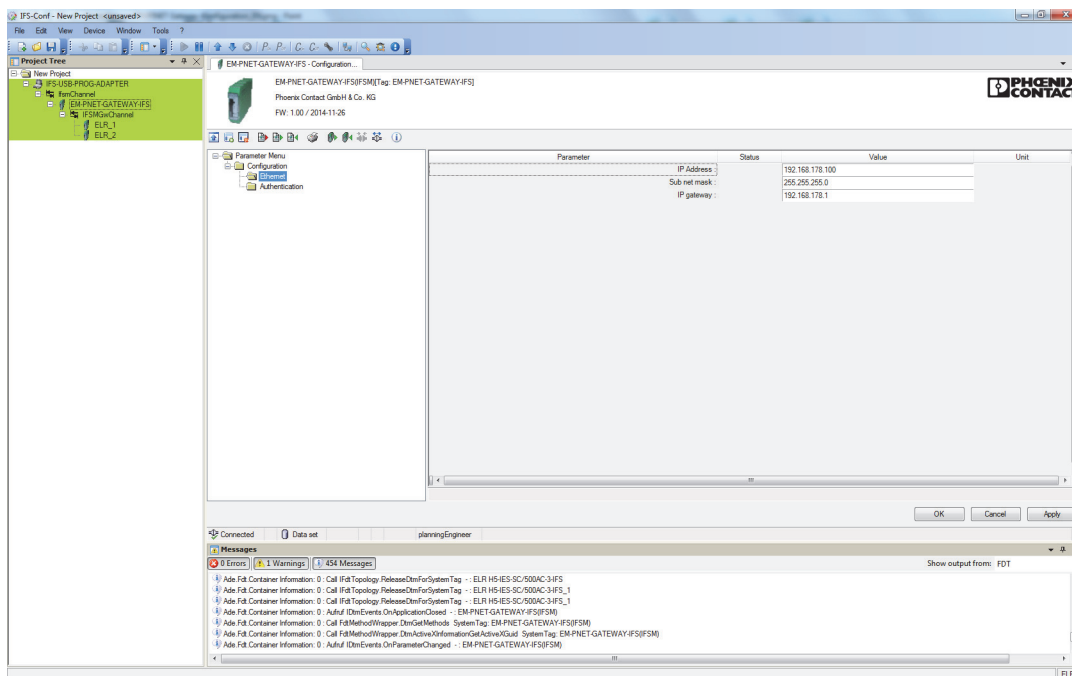

Figure 35 PROFINET gateway settings – Ethernet

Parameter	Selection	Interval	Program side
IP address	-		192.168.178.100
Subnet mask	-		255.255.255.0
IP gateway	-		192.168.178.1

EM-PNET-GATEWAY-IFS and ELR H5-IES-SC/500AC-3-IFS

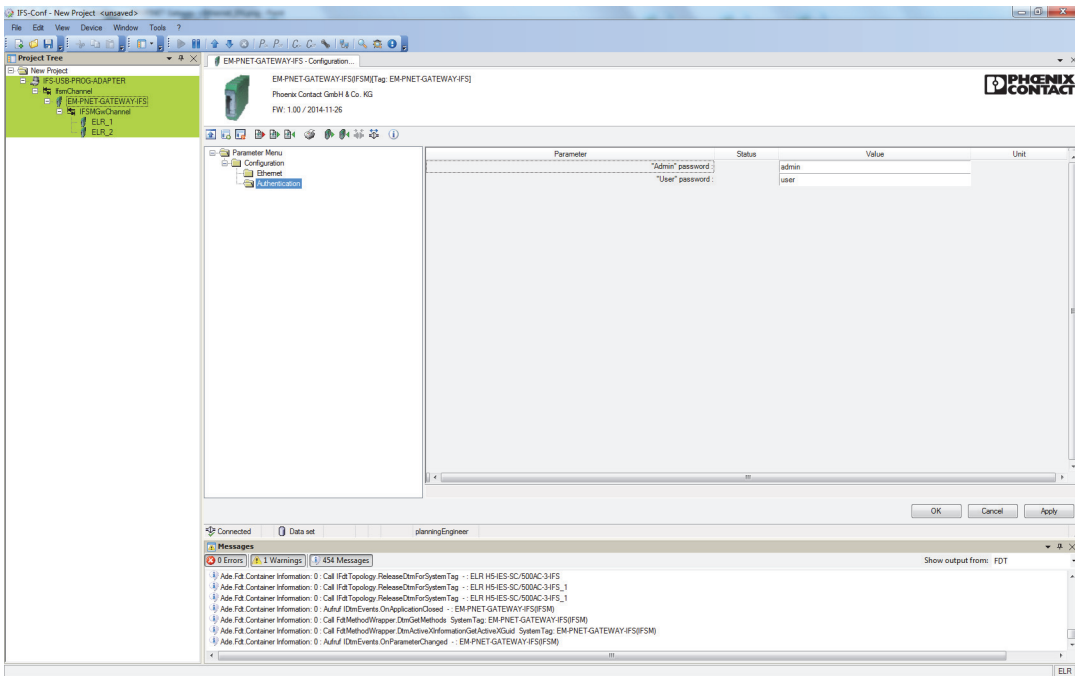

Figure 36 PROFINET gateway settings – authentication

Parameter	Selection	Interval	Program side
“Admin” password	– Max. 32 characters	-	Admin
“User” password	– Max. 32 characters	-	User

EM-PNET-GATEWAY-IFS and ELR H5-IES-SC/500AC-3-IFS

4.2.7 Diagnostics dialog

You can continuously check the current states of the gateway via the diagnostics dialog.

Errors for individual devices can be displayed in the Interface system communication.

1. Right-click on the gateway.
2. Select "Diagnosis" to open the dialog.

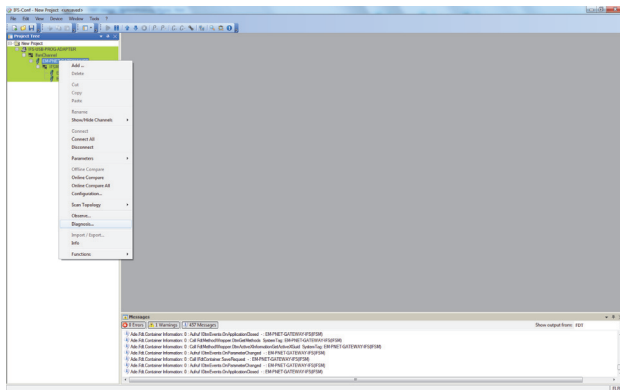

Figure 37 Opening the diagnostics dialog

Overview



The overview dialog contains all operating data and status messages that provide initial information.

This dialog provides a quick and comprehensive overview of the state of the gateway.

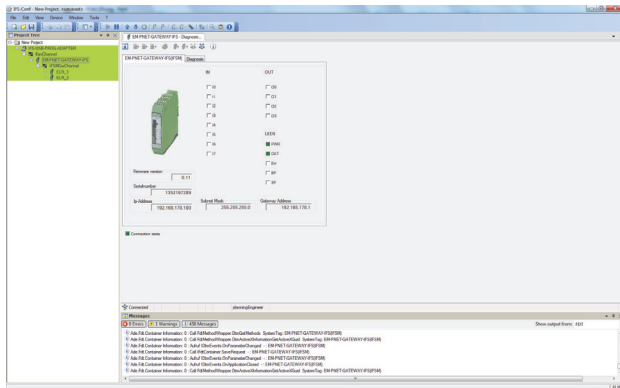

Figure 38 Tab 1 of the gateway diagnostics dialog

Diagnostics

The diagnostics dialog displays all status messages of devices that are connected to an Interface system bus.

It provides a quick overview of the state of Interface system communication.

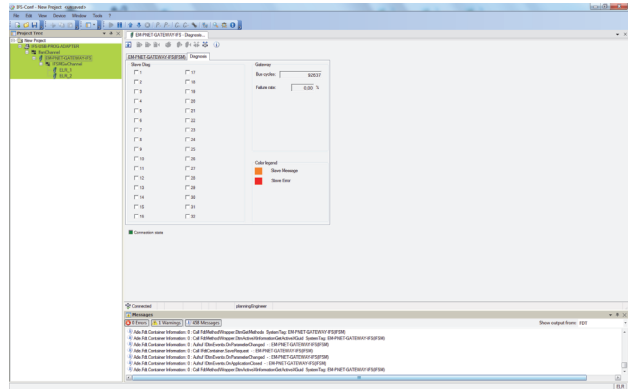

Figure 39 Tab 2 of the gateway diagnostics dialog

4.2.8 Saving the project

You can save the project for further use of the project data, e.g., for comparable stations, as follows:

1. Click on "File, Save As..."
2. Enter a name.

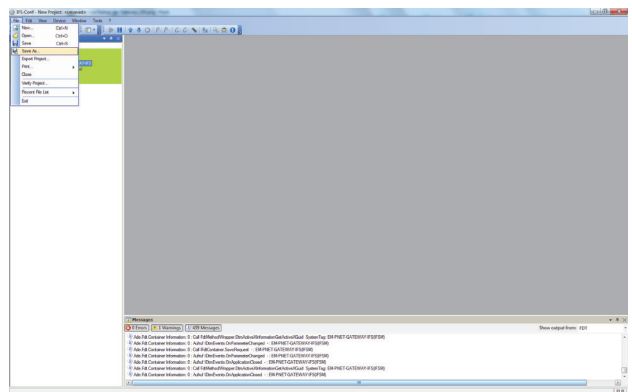

Figure 40 Saving the project

4.2.9 Device replacement

Device replacement of the hybrid motor starter, which was parameterized using the IFS-Conf tool and which is connected to an EM-PNET-GATEWAY-IFS, must be carried out as follows.

1. The relevant device must be replaced with an identical hybrid motor starter.
2. The saved IFS-Conf project must be reloaded on the station.

4.3 Configuration via the web server

Data for the Interface system station can be viewed via the web server of the Ethernet-based gateway.

You can set up the Interface system station using an installation wizard.

You cannot alter the process data that is selected as this is selected according to a defined profile.

Using an Internet browser, you can set up the web server via the gateway IP address.

4.3.1 Calling the web server

Enter the gateway IP address in the address line of an Internet browser.

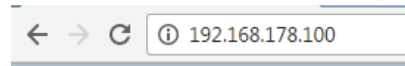

Figure 41 Address line of the Internet browser

The initial view provides an overview of the connected gateway module.

This page is freely accessible.

You cannot alter the configuration.

You can select "German" or "English" as the language and log into the administration area.

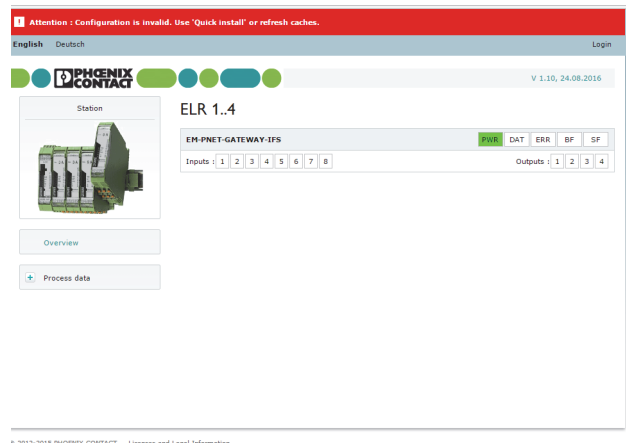

Figure 42 Web server start page

EM-PNET-GATEWAY-IFS and ELR H5-IES-SC/500AC-3-IFS

Designation	Selection	Default value
LEDs	- PWR; DAT; ERR; BF; SF	
Inputs	- 1; 2; 3; 4; 5; 6; 7; 8	
Outputs	- 1; 2; 3; 4	
Installation site	- Max. 32 characters	Kabinet name
Contact person	- Max. 32 characters	Name



NOTE:

So long as the message highlighted in red is displayed at the top of the view, we cannot guarantee that the view that is displayed matches the physical Interface system station.
Follow the instructions.



Figure 43 Message during initial startup

4.3.2 Setting up the Interface system station

You can configure an Interface system station via the web server using an installation wizard.

This configuration can be done as follows:

1. To access the administration area, click on the “Login” button.

The authentication dialog appears.

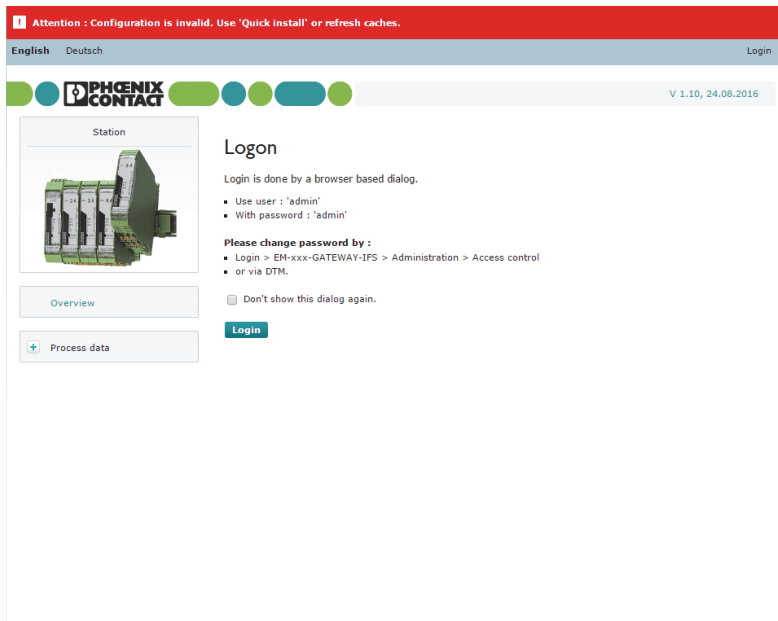

Figure 44 Login

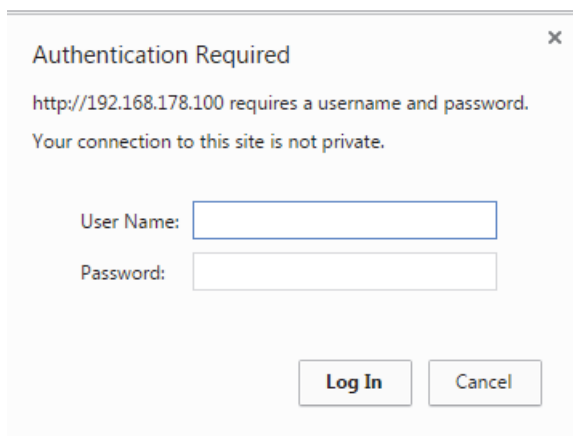

Figure 45 Authentication dialog

2. The default values for the administration area are:

User name	admin
Password	admin

After logging in and during initial startup, go to the installation wizard.

1. Select the relevant application.
In this case it is "Motor starter".

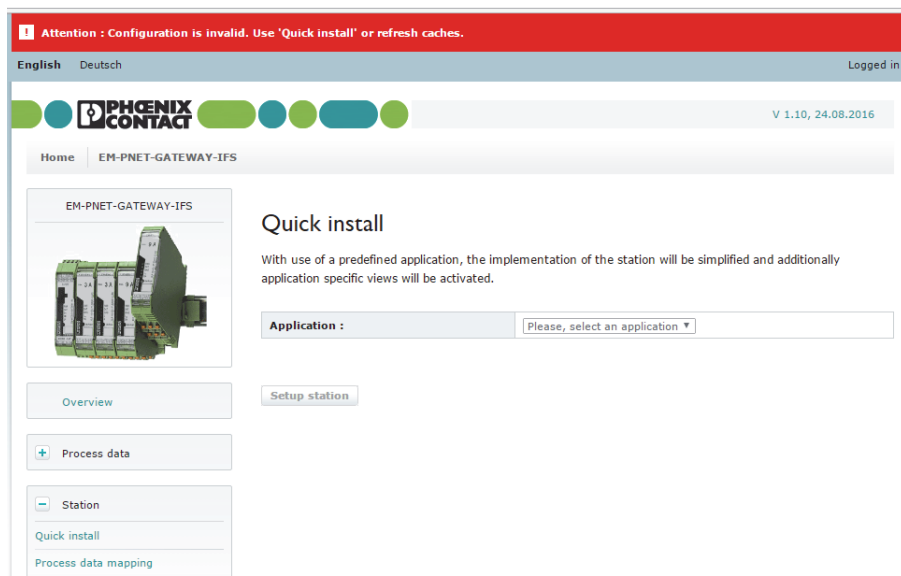

Figure 46 Installation wizard

EM-PNET-GATEWAY-IFS and ELR H5-IES-SC/500AC-3-IFS

Applications:

Application	Description
User-defined, via DTM	Carry out configuration using the IFS-Conf program.
Motor starter	Carry out configuration via the installation wizard. In this application, you can configure up to eight hybrid motor starters.
Motor starter + digital IOs	Carry out configuration via the installation wizard. In this application, you can configure up to eight hybrid motor starters and an additional IO module.
Motor starter + TRISAFE	Carry out configuration via the installation wizard. In this application, you can configure up to eight hybrid motor starters and a small-scale safety controller.
TRISAFE - Monitoring	Carry out configuration via the installation wizard. They represent TRISAFE inputs and outputs.

All relevant settings for the station can be selected in the following dialog.

Attention : Configuration is invalid. Use 'Quick install' or refresh caches.

English Deutsch Logged in

PHOENIX CONTACT V 1.10, 24.08.2016

Home EM-PNET-GATEWAY-IFS

EM-PNET-GATEWAY-IFS

Quick install

With use of a predefined application, the implementation of the station will be simplified and additionally application specific views will be activated.

Application : Motor control

Description : Application : Motorstarter
Application example of motorstarter.At 'Home' view a summary of relevant data are shown.

ELRs : 2

Control type : Switch (right, left)

Required devices :

ELR_1 : ELR H.../500AC...-IFS, Firmware:1.xx

ELR_2 : ELR H.../500AC...-IFS, Firmware:1.xx

Setup station

Figure 47 Installation wizard dialog

Settings	
Application	Motor starter
Description	The "Home" page displays the relevant station data.
ELRs	You can integrate up to eight ELRs into the station.
Control type	Choose between a button function (right, stop, left) or a switch function (right, left).
Required devices	The devices required for the application are listed here.

Control:

Switch

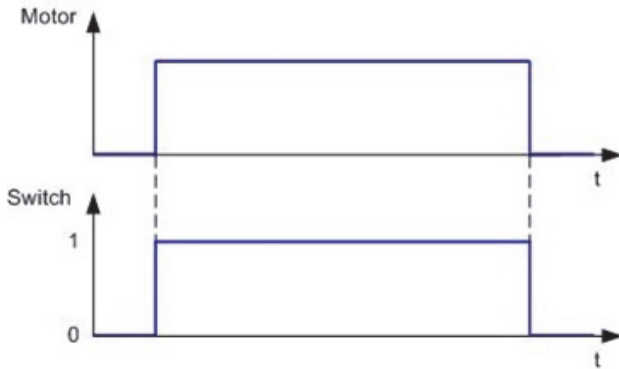

Figure 48 Switching behavior of the switch

Button

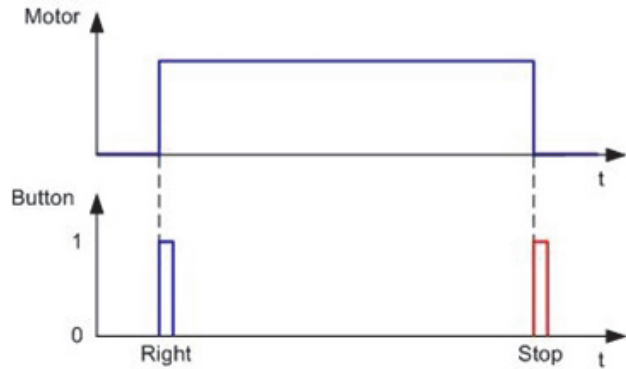

Figure 49 Switching behavior of the button

1. Click on the "Setup station" button to set up the station. This stops cyclic communication between the station devices.
2. Press the "Set/Reset" buttons on the hybrid motor starters in succession.

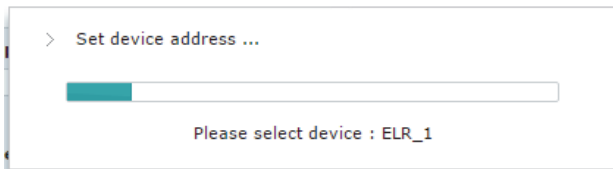

Figure 50 Prompt to press the button

EM-PNET-GATEWAY-IFS and ELR H5-IES-SC/500AC-3-IFS

The project data is automatically written to the station.

The process data which is stored in the selected profile is automatically assigned.

Process data item	Communication direction	Description	Interface system device
DIN	Input	Digital inputs of the gateway	EM-PNET-GATEWAY-IFS
DOUT	Output	Digital outputs of the gateway	EM-PNET-GATEWAY-IFS
DEVICE_STATE	Input	Current device status of the hybrid motor starter	ELR H5-IES-SC/500AC-3-IFS_1
CURRENT_MAX_AMP	Input	Current maximum current flow of the three phases of the connected electrical machine	ELR H5-IES-SC/500AC-3-IFS_1
CHN_STATE_LO	Input	Coding of the individual possible device messages and warnings	ELR H5-IES-SC/500AC-3-IFS_1
CONTROL_BUTTON	Output	Control word of the hybrid motor starter	ELR H5-IES-SC/500AC-3-IFS_1
DEVICE_STATE	Input	Current device status of the hybrid motor starter	ELR H5-IES-SC/500AC-3-IFS_2
CURRENT_MAX_AMP	Input	Current maximum current flow of the three phases of the connected electrical machine	ELR H5-IES-SC/500AC-3-IFS_2
CHN_STATE_LO	Input	Coding of the individual possible device messages and warnings	ELR H5-IES-SC/500AC-3-IFS_2
CONTROL_BUTTON	Output	Control word of the hybrid motor starter	ELR H5-IES-SC/500AC-3-IFS_2

Depending on the configuration, the web server automatically switches to the "Home" page.

The most important station data is listed on the "Home" page.

The message mentioned above no longer appears as the web server data matches the station configuration.

EM-PNET-GATEWAY-IFS and ELR H5-IES-SC/500AC-3-IFS

4.3.3 Process data

- The current process data values can be viewed via the "Process data" menu item.
- The process data is automatically assigned to Access 1 and Access 2.



Adjust the motor nominal current setting in the configuration part of the ELR H5-IES-SC/500AC-3-IFS devices of the hybrid motor starters. The procedure is described below.

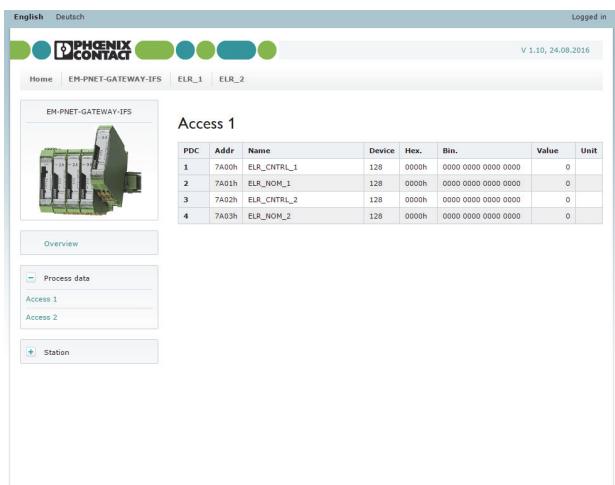

Figure 51 Process data in Access 1

4.3.4 Station

You can call the installation wizard again via the "Station" menu item.

If you would like to configure a new station, proceed as described in "Setting up the Interface system station" on page 20.

Process data mapping documents which process data can be called under which address.

The process data words are broken down into bits and identified.

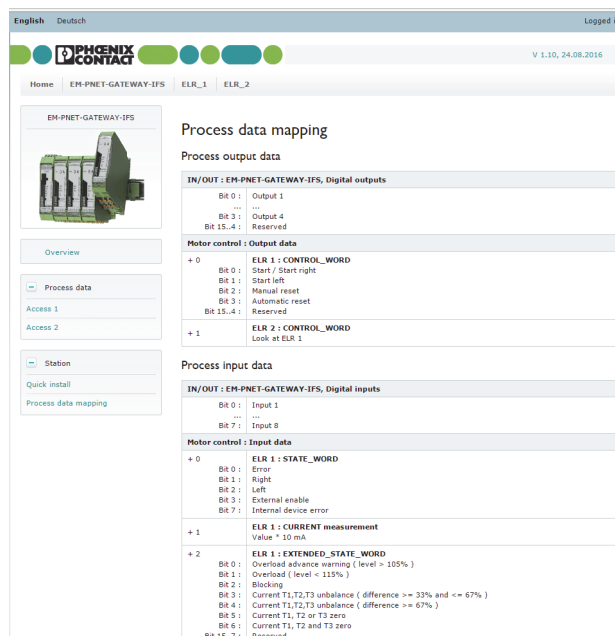

Figure 52 Process data mapping

EM-PNET-GATEWAY-IFS and ELR H5-IES-SC/500AC-3-IFS

Process data assignment

Process output data	
IN/OUT: EM-PNET-GATEWAY-IFS, Digital outputs	
Bit 0	Output 1
Bit 1	Output 2
Bit 2	Output 3
Bit 3	Output 4
Bit 4..15	Reserved
Output PDCs 1..15	
+ 0	ELR 1: CONTROL_WORD
Bit 0	Start left
Bit 1	Stop
Bit 2	Start/Start right
Bit 3	Automatic reset
Bit 4, 5	Reserved
Bit 6	Manual reset
Bit 7..15	Reserved
+ 1	ELR 2: CONTROL_WORD
Bit 0	Start left
Bit 1	Stop
Bit 2	Start/Start right
Bit 3	Automatic reset
Bit 4, 5	Reserved
Bit 6	Manual reset
Bit 7..15	Reserved

Process input data	
IN/OUT: EM-PNET-GATEWAY-IFS, Digital Inputs	
Bit 0	Input 1
Bit 1	Input 2
Bit 2	Input 3
Bit 3	Input 4
Bit 4	Input 5
Bit 5	Input 6
Bit 6	Input 7
Bit 7	Input 8
Input PDCs 33..48	
+ 0	ELR 1: STATE_WORD
Bit 0	Left
Bit 1	Stop
Bit 2	On / Right
Bit 3	115%
Bit 4	-
Bit 5	HHOP (hand-held operator panel)
Bit 6	Error
Bit 7	Message
+ 1	ELR 1: Current measurement
Bit 1..7	Value * 10 mA
+ 2	ELR 1: Extended State
Bit 0	Overload advanced warning (level \geq 105%)
Bit 1	Overload (level \geq 115%)
Bit 2	Blocking
Bit 3	Current T1, T2, T3 unbalance (difference \geq 33% and \leq 67%)
Bit 4	Current T1, T2, T3 unbalance (difference $>$ 67%)
Bit 5	Current T1, T2 or T3 zero
Bit 6	Current T1, T2 and T3 zero
Bit 7..15	Reserved
+3	ELR 2: STATE_WORD
Bit 0	Left
Bit 1	Stop
Bit 2	On / Right
Bit 3	115%
Bit 4	-
Bit 5	HHOP (hand-held operator panel)
Bit 6	Error
Bit 7	Message
+ 4	ELR 2: Current measurement

EM-PNET-GATEWAY-IFS and ELR H5-IES-SC/500AC-3-IFS

Process input data [...]	
Bit 1..7	Value * 10 mA
+ 5	ELR 2: Extended State
Bit 0	Overload advanced warning (level \geq 105%)
Bit 1	Overload (level \geq 115%)
Bit 2	Blocking
Bit 3	Current T1, T2, T3 unbalance (difference \geq 33% and \leq 67%)
Bit 4	Current T1, T2, T3 unbalance (difference $>$ 67%)
Bit 5	Current T1, T2 or T3 zero
Bit 6	Current T1, T2 and T3 zero
Bit 7..15	Reserved

4.3.5 Device views

Under the “Configuration” menu item on the web server, you can view device-specific states and modify properties.

EM-PNET-GATEWAY-IFS

Monitoring, Diagnose – Overview

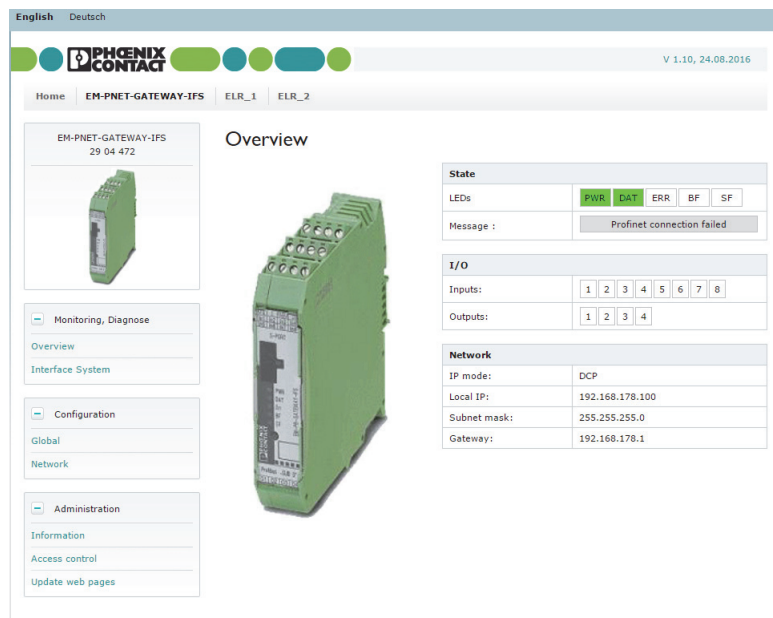

Figure 53 Overview

State	
LEDs	Display of status LEDs
Message	Display of messages and errors that are present
I/O	
Inputs	Displays the inputs at which a signal is present
Outputs	Displays the outputs that are active
Network	
IP mode	DCP
Local IP	Local IP address of the gateway
Subnet mask	Local subnet mask of the gateway
Gateway	Local IP address of the default gateway

Monitoring, Diagnose – Interface System

The screenshot shows the Phoenix Contact web interface for monitoring the Interface System. At the top, there are language options (English, Deutsch) and the Phoenix Contact logo. Below the logo, there are navigation links for Home, EM-PNET-GATEWAY-IFS, ELR_1, and ELR_2. The main content area is titled 'Interface System' and contains two main sections: 'IF system' and 'Devices'. The 'IF system' section displays a table with the following data:

IF system	
Update-Time:	65.0 ms
Bus cycles:	2788
Bit error(s):	0
Bus error(s):	0

The 'Devices' section displays a table with the following data:

Devices		
1	ELR_1 ELR H5-IES-SC/500AC-3-IFS	Firmware : 1.10 Hardware : 01
2	ELR_2 ELR H5-IES-SC/500AC-3-IFS	Firmware : 1.10 Hardware : 01

On the left side of the interface, there is a navigation menu with the following sections:

- Monitoring, Diagnose
 - Overview
 - Interface System
- Configuration
 - Global
 - Network
- Administration
 - Information
 - Access control
 - Update web pages

Figure 54 Interface System

Displays the state of the Interface system bus

IF system	
Update-Time	Cyclic update time of the Interface system bus
Bus cycles	Number of bus cycles that have been completed successfully
Bit error(s)	Number of bit errors that occurred during communication
Bus error(s)	Number of bus errors that occurred during communication

The status of the individual Interface system devices is displayed.

Devices		
1	ELR_1 ELR H5-IES-SC/500AC-3-IFS	Firmware : 1.10 Hardware : 01
2	ELR_2 ELR H5-IES-SC/500AC-3-IFS	Firmware : 1.10 Hardware : 01

Figure 55 Status of the individual Interface system devices

EM-PNET-GATEWAY-IFS and ELR H5-IES-SC/500AC-3-IFS

Configuration – Global

The screenshot displays the 'Global' configuration page for the EM-PNET-GATEWAY-IFS device. The interface includes a top navigation bar with 'English' and 'Deutsch' language options, and a breadcrumb trail: Home > EM-PNET-GATEWAY-IFS > ELR_1 > ELR_2. On the left, there is a sidebar menu with three main sections: 'Monitoring, Diagnose' (containing Overview and Interface System), 'Configuration' (containing Global and Network), and 'Administration' (containing Information, Access control, and Update web pages). The main content area features a product image of the EM-PNET-GATEWAY-IFS device (part number 29 04 472) and a 'Global' configuration form. The form has an 'Identification' section with the following fields: 'Application ID' (value: EM-PNET-GATEWAY-IFS), 'Profinet station name' (empty), 'Installation' (value: Kabinet name), 'Function Tag' (value: Name), and 'Date' (empty). Below the form are four buttons: 'Print', 'Factory Defaults', 'Upload', and 'Download'. The footer of the page contains the copyright notice: © 2012-2015 PHOENIX CONTACT Licenses and Legal Information.

Figure 56 Global

Parameter	Selection	Interval	Program side
Application ID	– Max. 32 characters	-	EM-PNET-GATEWAY-IFS
Profinet station name	–	-	-
Installation	– Max. 32 characters	-	Kabinet name
Function Tag	– Max. 32 characters	-	Name
Date	– Max. 32 characters	-	-

Configuration – Network

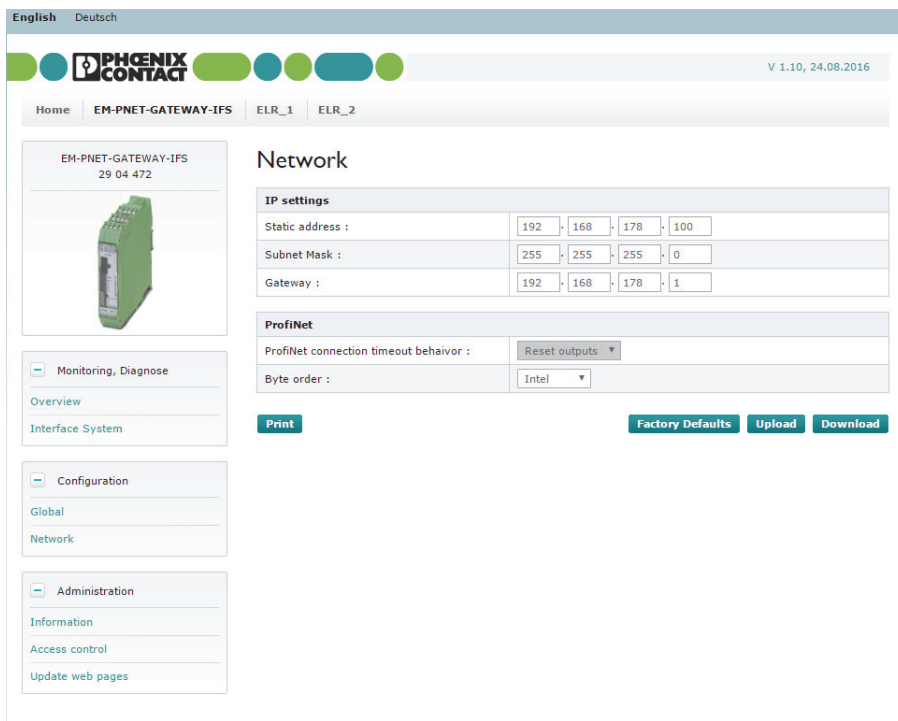

Figure 57 Network

Parameter	Selection	Interval	Program side
Static address	-	-	192.168.178.100
Subnet Mask	-	-	255.255.255.0
Gateway	-	-	192.168.178.1

Parameter	Selection	Interval	Program side
ProfiNet connection timeout behavior	- Reset outputs	-	Reset outputs
Byte order	- Intel	-	Intel
	- Motorola		

EM-PNET-GATEWAY-IFS and ELR H5-IES-SC/500AC-3-IFS

Administration – Information

English Deutsch

PHOENIX CONTACT V 1.10, 24.08.2016

Home EM-PNET-GATEWAY-IFS ELR_1 ELR_2

EM-PNET-GATEWAY-IFS
29 04 472



Monitoring, Diagnose

Overview

Interface System

Configuration

Global

Network

Administration

Information

Access control

Update web pages

Information

Vendor	
Vendor :	Phoenix Contact GmbH & Co. KG
Address :	Flachsmarktstr. 8, 32825 Blomberg, Germany
Home page :	phoenixcontact.com

Device data	
Name :	EM-PNET-GATEWAY-IFS
Order no. :	29 04 472
Serial no. :	1352197289
Firmware version :	1.11
Hardware version :	01
Configuration version :	0001
Web interface version :	V 1.10, 24.08.2016
MAC-Address :	00:A0:45:93:18:48

© 2012-2015 PHOENIX CONTACT Licenses and Legal Information

Figure 58 Information

Vendor	
Vendor	Phoenix Contact GmbH & Co. KG
Address	Flachsmarktstr. 8, 32825 Blomberg, Germany
Home page	phoenixcontact.com

Device data	
Name	EM-PNET-GATEWAY-IFS
Order no.	29 04 472
Serial no.	Device-specific
Firmware version	Device-specific
Hardware version	Device-specific
Configuration version	Device-specific
Web interface version	Device-specific
MAC-Address	Device-specific

Administration – Access control

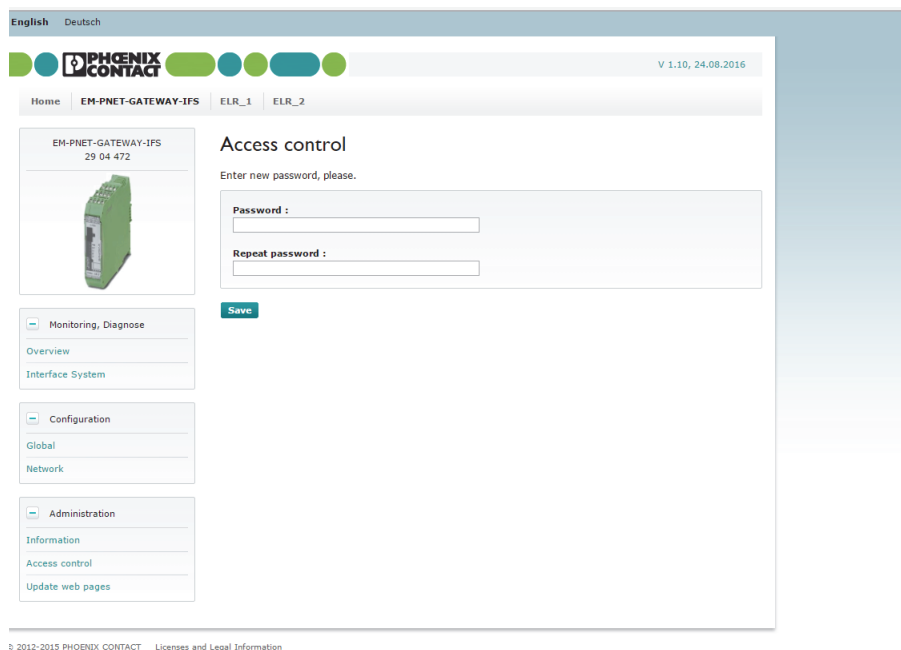

Figure 59 Access control

You can specify a new password under the “Access control” menu item.

Administration – Update web pages

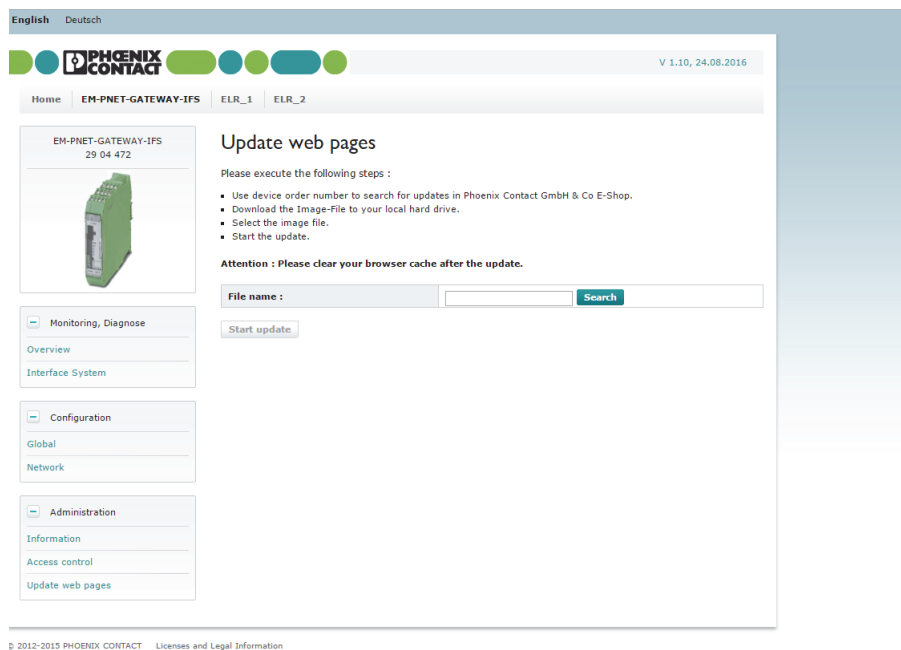

Figure 60 Update web pages

EM-PNET-GATEWAY-IFS and ELR H5-IES-SC/500AC-3-IFS

1. Select the new image file from your directory.
2. Start the update process.

**NOTE:**

Delete the browser cache following an update.

ELR H5-IES-SC/500AC-3-IFS**Monitoring, Diagnose – Overview**

English Deutsch

PHOENIX CONTACT V 1.10, 24.08.2016

Home EM-PNET-GATEWAY-IFS ELR_1 ELR_2

EM-PNET-GATEWAY-IFS
29 04 472



Monitoring, Diagnose

Overview
Interface System

Configuration

Global
Network

Administration

Information
Access control
Update web pages

Overview



State	
LEDs	PWR DAT ERR BF SF
Message :	Profinet connection failed

I/O	
Inputs:	1 2 3 4 5 6 7 8
Outputs:	1 2 3 4

Network	
IP mode:	DCP
Local IP:	192.168.178.100
Subnet mask:	255.255.255.0
Gateway:	192.168.178.1

© 2012-2015 PHOENIX CONTACT Licenses and Legal Information

Figure 61 Overview

EM-PNET-GATEWAY-IFS and ELR H5-IES-SC/500AC-3-IFS

State	
LEDs	Display of status LEDs
Motor	Display of motor status
Message	Display of messages and errors that are present

Manual control	
Manual	If you have started manual control via the "Manual" button, you can control the motor via the web interface. (Test mode)

Motor protection	
I [A]	Current consumption of the motor
Max. current [A]	Maximum current consumption of the motor
Nominal current [A]	Current nominal current setting
Energy [%]	Current thermal load
Motor protection events	Number of motor protection events

Counters	
Operating time	Controlled total time
Switching cycles	Number of switching cycles performed

Monitoring, Diagnose – Trend

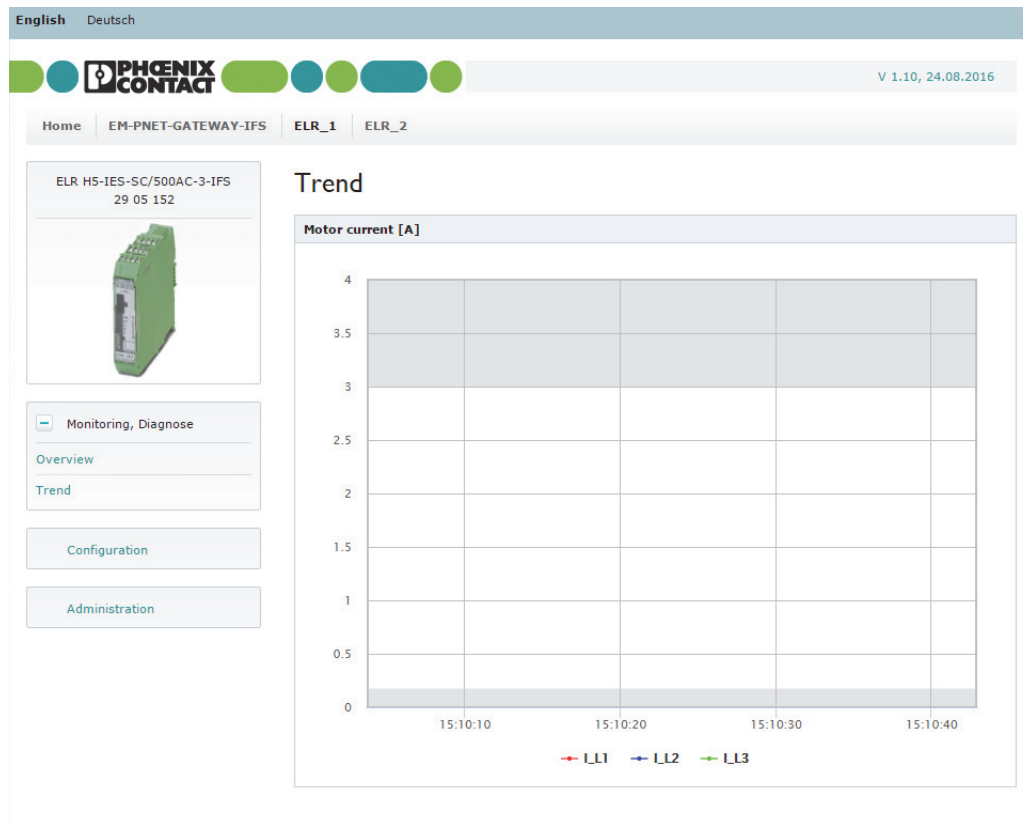

© 2012-2015 PHOENIX CONTACT Licenses and Legal Information

Figure 62 Trend

The current current consumption can be displayed graphically.

Configuration

English Deutsch

PHOENIX CONTACT V 1.10, 24.08.2016

Home EM-PNET-GATEWAY-IFS ELR_1 ELR_2

ELR H5-IES-SC/500AC-3-IFS
29 05 152

Configuration

Global

Application tag :

Fix current :

[Print](#) [Factory Defaults](#) [Upload](#) [Download](#)

Monitoring, Diagnose

Overview

Trend

Configuration

Administration

© 2012-2015 PHOENIX CONTACT Licenses and Legal Information

Figure 63 Configuration

The system ID (application tag) and current nominal current can be viewed and adjusted in the configuration view.

1. The "Upload" button can be used to read the current values from the device and display them.
2. Use the "Download" button to write the values to the device.

EM-PNET-GATEWAY-IFS and ELR H5-IES-SC/500AC-3-IFS

Global			
Parameter	Selection	Interval	Program side
Application tag	- Max. 32 characters	-	ELR
Fix current	0.6 A device - 0.075 A - 0.110 A - 0.145 A - 0.180 A - 0.215 A - 0.250 A - 0.285 A - 0.320 A - 0.355 A - 0.390 A - 0.425 A - 0.460 A - 0.495 A - 0.530 A - 0.565 A - 0.600 A 3 A device - 0.18 A - 0.30 A - 0.44 A - 0.60 A - 0.68 A - 0.88 A - 1.00 A - 1.10 A - 1.20 A - 1.50 A - 1.60 A - 1.90 A - 2.10 A - 2.40 A - 2.70 A - 3.00 A	-	Smallest setting

EM-PNET-GATEWAY-IFS and ELR H5-IES-SC/500AC-3-IFS

Global [...]			
Parameter	Selection	Interval	Program side
	9 A device		
	- 1.50 A		
	- 2.00 A		
	- 2.50 A		
	- 3.00 A		
	- 3.50 A		
	- 4.00 A		
	- 4.50 A		
	- 5.00 A		
	- 5.50 A		
	- 6.00 A		
	- 6.50 A		
	- 7.00 A		
	- 7.50 A		
	- 8.00 A		
	- 8.50 A		
	- 9.00 A		

EM-PNET-GATEWAY-IFS and ELR H5-IES-SC/500AC-3-IFS

Administration

© 2012-2015 PHOENIX CONTACT Licenses and Legal Information

Figure 64 Administration

Vendor	
Vendor	Phoenix Contact GmbH & Co. KG
Address	Flachmarktstr. 8, 32825 Blomberg, Germany
Home page	phoenixcontact.com

Device data	
Name	ELR H5-IES-SC/500AC-3-IFS
Order no.	29 05 152
Serial no.	Device-specific
Firmware version	Device-specific
Hardware version	Device-specific
Configuration version	Device-specific

4.3.6 Device replacement

The hybrid motor starters which are connected to the EM-PNET-GATEWAY-IFS and were configured via the web server can be replaced as follows.

1. Replace the relevant hybrid motor starter with an identical new hybrid motor starter.
2. Press the button on the EM-PNET-GATEWAY-IFS for at least twelve seconds to assign the Interface system address.
The module switches to “Interface system address assignment” mode.
3. Press the “Set” buttons on the hybrid motor starters in succession.
4. Once all the hybrid motor starters have been assigned an Interface system address, press the button on the EM-PNET-GATEWAY-IFS for six seconds.
Address assignment is complete.
The new module has automatically adopted the motor nominal current setting of the old device.
The Interface system station is operational again.

5 PC Worx

If you wish to map device descriptions, the Phoenix Contact automation environment uses FDCML files.

5.1 Inserting an FDCML in the folder structure

1. Place the FDCML files in a special folder: C:\Users\Public\Documents\FDCML10\PROFINet\Phoenix Contact.
This folder contains the main description files for installed devices and their mapping files.
2. The “Modules” subfolder contains the modules that you can connect to a configured device.
3. Place the EM-PNET-GATEWAY-IFS_v01_1.11.xml and em_pnet_gateway_ifs_device.ico files in directory C:\Users\Public\Documents\FDCML10\PROFINet\Phoenix Contact.
4. Place the remaining files in the “Modules” subfolder: C:\Users\Public\Documents\FDCML10\PROFINet\Phoenix Contact\Modules.

5.2 Integrating FDCMLs

1. Create a project.
2. Open the device catalog to import the device.
3. Select “Import Device” in the context menu.

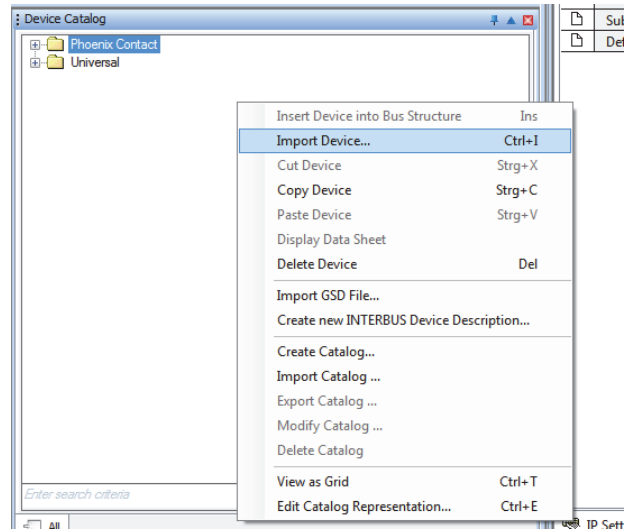

Figure 65 Import Device



Follow the instructions.

4. Select file C:\Users\Public\Documents\FDCML10\PROFINet\Phoenix Contact\EM-PNET-GATEWAY-IFS_v01_1.11.xml.
5. The FDCML file must be imported successfully.
6. Select the EM-PNET-GATEWAY-IFS device in the device catalog.
7. Insert the selected device in the project structure.

EM-PNET-GATEWAY-IFS and ELR H5-IES-SC/500AC-3-IFS

5.3 Selecting modules

1. Insert additional modules in the project structure and link the process data to the program variables.
2. Select the EM-PNET-GATEWAY-IFS in the project tree.

Choose the modules in the module catalog.

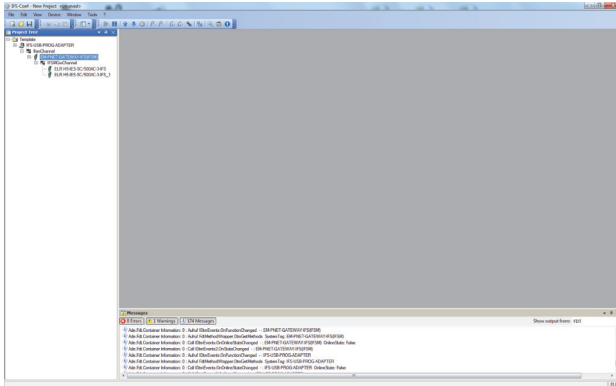

Figure 66 Project tree

Using the IFS-Conf software, assign the process data to the project.

- Module Input PDCs 1...16 contains the first 15 process data items.
- Input PDCs 17...32 contains the next 16 process data items.



For instructions on how to configure the process data using the IFS-Conf software, please refer to the relevant documentation, which can be downloaded via the product at phoenixcontact.net/products.

If you used the web server to carry out the configuration, the first process data item starts in Input PDCs 33..48 and follows the same sequence.

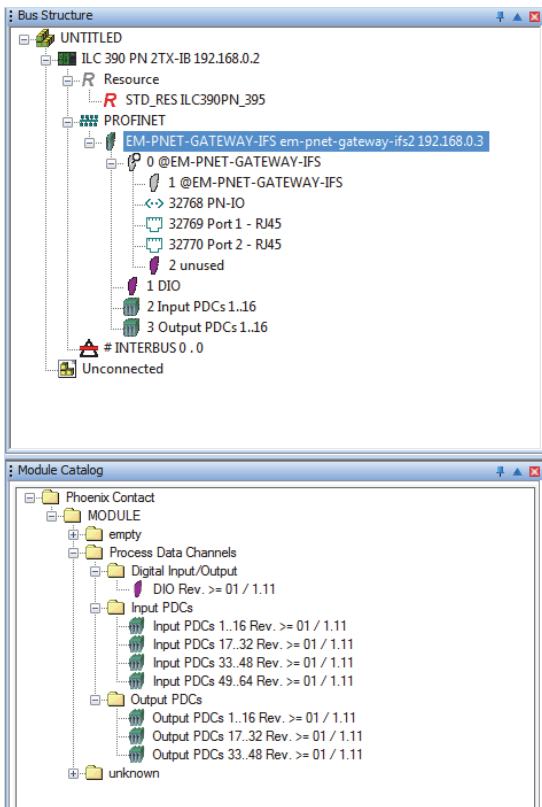

Figure 67 Module catalog

5.4 PROFINET settings

All the necessary device details, such as the DNS name (application ID), can be entered in the settings dialog.

Name	Value
Vendor	Phoenix Contact
VendorID	0x00B0
Designation	EM-PNET-GATEWAY-IFS
DeviceID	0x8000
Functional description	EM-PNET-GATEWAY-IFS
Device type	Gateway
Device family	IF-System
Order number	2904472
Revision	01 / 1.11
DNS Name	em-pnet-gateway-ifs
Station Name	
Device Name	
Module Equipment ID	
IP Address	192.168.0.3
Subnetmask	255.255.255.0
Default Gateway	
Reduction ratio input	8 ms
Reduction ratio output	8 ms
Faulty telegrams until connection is aborted	24
Monitoring Time Inputs (ms)	192
Monitoring Time Outputs (ms)	192
Operation in case of configuration differen...	No
Log connection state	Yes
Drive BF	Yes
Substitute value behavior of inputs	Set to zero
Connection establishment at startup	Yes
Node ID	22

Figure 68 Device details

5.5 Process data assignment

Assign the relevant program variables to the transferred EM-PNET-GATEWAY-IFS process data. The process data assignment workspace is used to do this.

The screenshot shows the 'Process Data Assignment' workspace. On the left, a tree view shows symbols/variables under 'STD_CNFG : ARM_L_40'. On the right, a device tree shows 'EM-PNET-GATEWAY-IFS em-pnet-gateway-ifs 192.168.0.3' with various inputs and outputs. Below these views are two tables:

Symbol/Variable	Data Type	Process Data Item
IN1	WORD	2 Input PDCs 1..16 \ IN 1
IN4	WORD	2 Input PDCs 1..16 \ IN 2
IN3	WORD	2 Input PDCs 1..16 \ IN 3
IN2	WORD	2 Input PDCs 1..16 \ IN 4

Device	Process Data Item	I/Q	Data Type	Byte.Bit	Address	Symbol/Variable
1 @E...	-PNIO_DATA_STATE	I	BYTE	0.0		
1 @E...	PNIO_IS_PRIMARY	I	BOOL	0.0		
1 @E...	PNIO_DATA_VALID	I	BOOL	0.2		
1 @E...	PNIO_APPL_RUN	I	BOOL	0.4		
1 @E...	PNIO_NO_DIAG	I	BOOL	0.5		
2 unu...	2 byte input	I	WORD	0.0		
2 unu...	DI 0.0	I	BOOL	0.0		
2 unu...	DI 0.1	I	BOOL	0.1		
2 unu...	DI 0.2	I	BOOL	0.2		
2 unu...	DI 0.3	I	BOOL	0.3		

Figure 69 Process data assignment

6 SIMATIC Manager

If you wish to map device descriptions, use GSDML files in the SIEMENS automation environment.

6.1 Integrating GSDMLs

1. Set up a project.
2. Integrate a GSDML in the hardware configuration.
3. Select the GSDML file in the “Options, Install GSD File” dialog box.

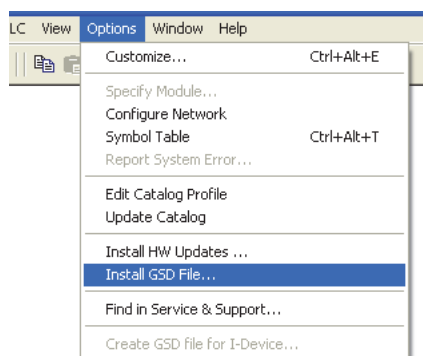

Figure 70 Install GSD File



Follow the instructions.

4. Select the EM-PNET-GATEWAY-IFS in the device catalog.
5. Insert the gateway in the project structure.

Specify the device details in the EM-PNET-GATEWAY-IFS properties dialog.

6.2 Selecting modules

1. In order to link the process data to the program variables, you must insert additional modules in the project structure.
2. Select the EM-PNET-GATEWAY-IFS in the project tree.
Choose from all the modules that are in the device catalog.

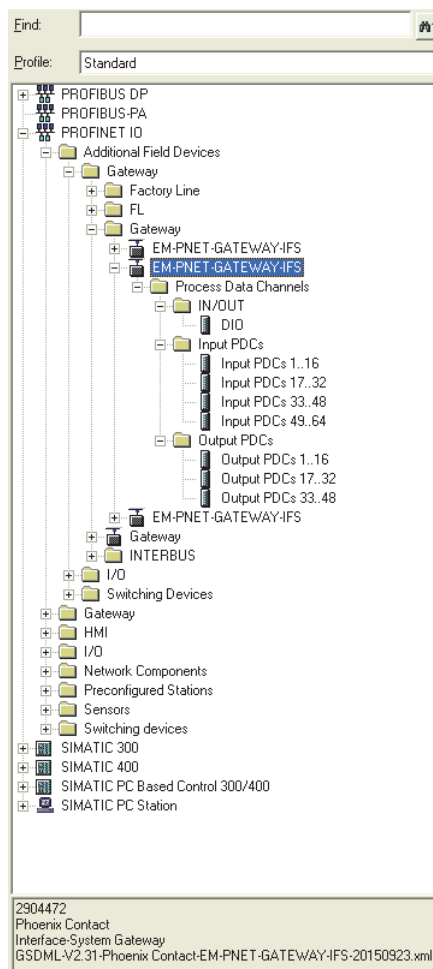

Figure 71 Project tree selection

Module Input PDCs 1...16 contains the first 15 process data items.

Input PDCs 17...32 contains the next 16 process data items.

Assign the process data for this project using the IFS-Conf software.



For instructions on how to configure the process data using the IFS-Conf software, please refer to the relevant documentation, which can be downloaded via the product at phoenixcontact.net/products.

If you used the web server to carry out the configuration, the first process data item starts in Input PDCs 33..48 and follows the same sequence.

6.3 Process data assignment

You can link the process data from the gateway to the relevant program variables via the address area of the modules.

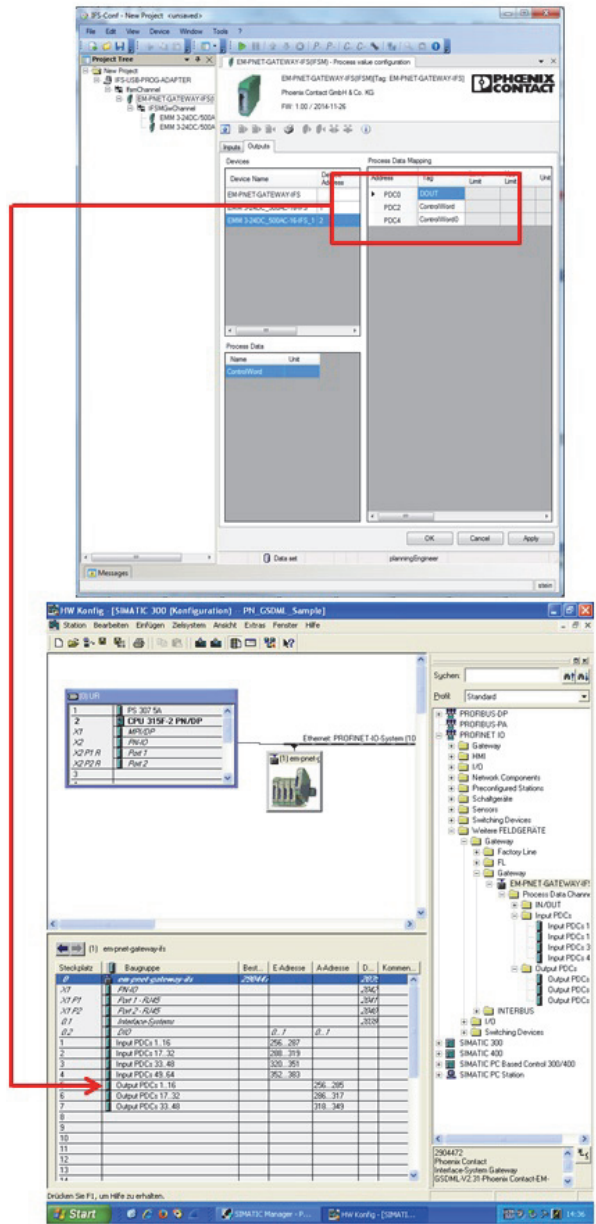
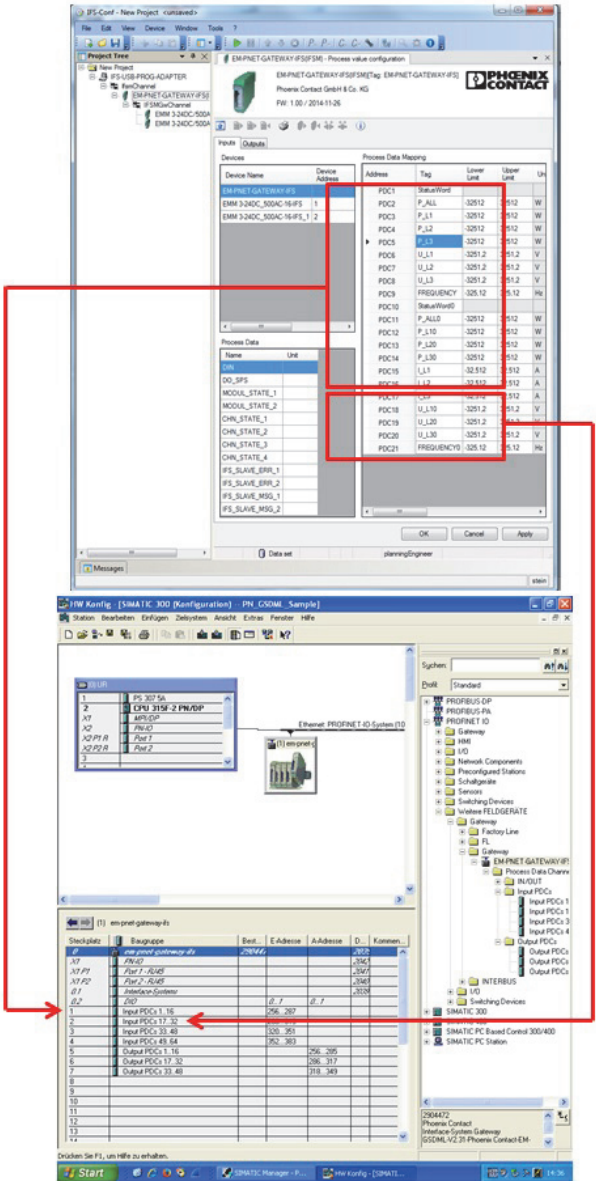

Figure 73 Linking program variables

Figure 72 Linking program variables



SCATTERGOOD & JOHNSON LTD

ELECTRICAL ENGINEERING & FLUID CONTROL DISTRIBUTORS

Est.1899

At Scattergood & Johnson Ltd, we pride ourselves on being a technical distributor to specialist industries.

Working with a range of quality product suppliers across a number of specialist markets, we are not your average 'box shifter' - we are your technical and supply chain partner.

We fully support every product we sell - for free! Our internal team and external sales engineers can answer any product or application question, no matter the complexity.

Backing up this technical ability is a range of 50,000+ products available from stock for nationwide next day delivery (same day if required!), or you can collect what you need from any of our trade counters around the UK.

Select your specialist interest below to learn more about how we can help.

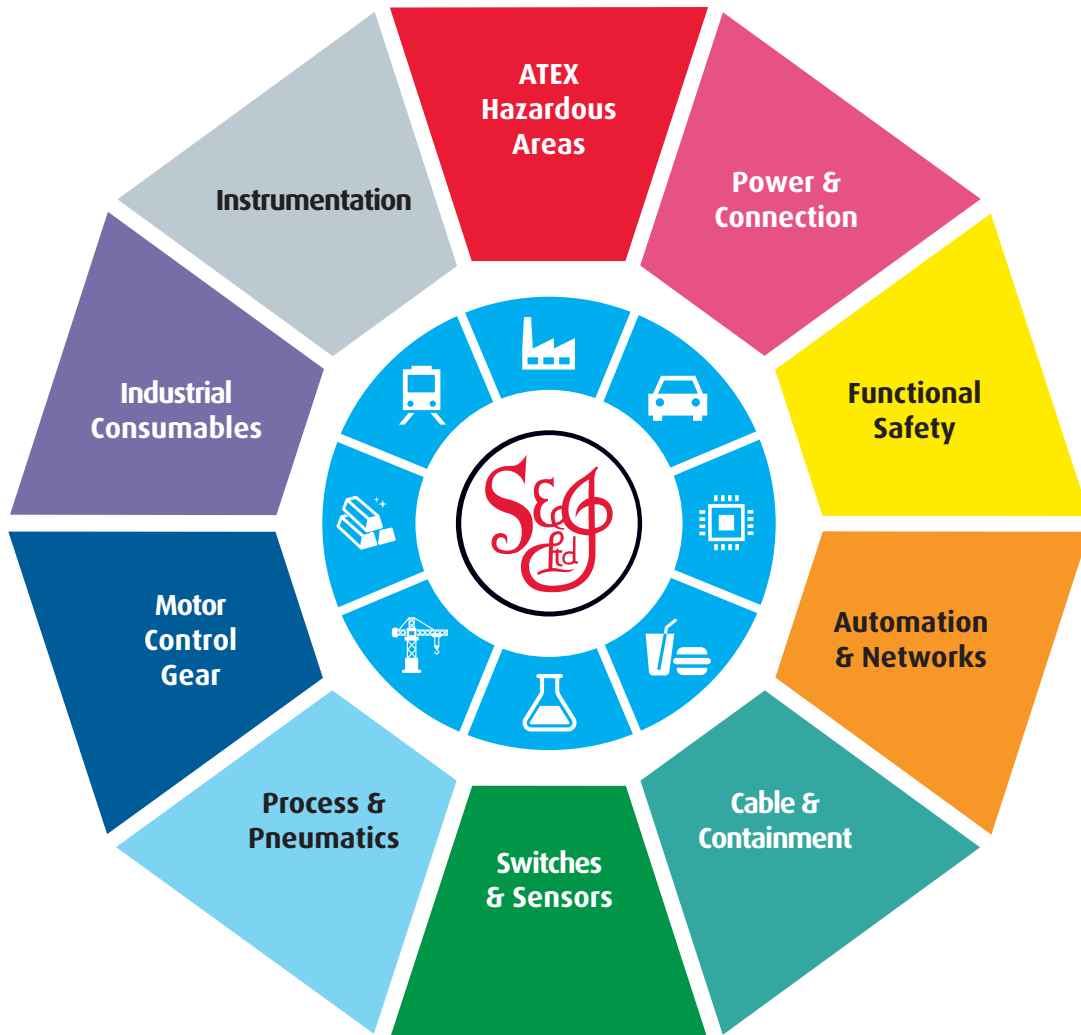

Online, In Branch and On the Road - Scattergood & Johnson Ltd, there when you need us.

www.scatts.co.uk