

PSR-PC50

SIL 3 coupling relay for safety-related switch on



Data sheet
105818_en_02

© PHOENIX CONTACT 2015-05-18

1 Description

The PSR-PC50 SIL coupling relay can be used for power adaptation and electrical isolation in Safe-State-ON applications up to SIL 3 according to IEC 61508 as well as IEC 61511.

The category 3 device is designed for installation in zone 2 potentially explosive areas.

By filtering the controller test pulses, premature failure of the safety relays is prevented.

The contact side is fully monitored for open circuit and short circuit as well as load and diagnostics supply voltage.

If an error occurs, the internal device input impedance is affected. As such, the test pulses sent from the controller are disrupted and the error is reported to the corresponding digital output without additional wiring effort.

Features

- SIL 3 coupling relays for safety-related switch on
- Applications: Energized-to-Safe / Class I Div II
- Complete monitoring of the load side for:
 - Open circuit
 - Short circuit
 - Presence of supply voltage for diagnostics and loads
- Error message output through interrupting test pulses of the higher-level controller
- Easy proof test
- Integrated DCS test pulse filter
- Low inrush current
- One undelayed enabling channel
- Option of screw or spring-cage terminal blocks for plug-in
- Special design for avoiding spurious trips
- Housing width 17.5 mm
- Compatible with EMERSON DeltaV SIS SLS1508 and CSL5 (further controller cards on request)



WARNING: Risk of electric shock

Observe the safety instructions in the corresponding section!



Make sure you always use the latest documentation.
It can be downloaded from the product at phoenixcontact.net/products.



This data sheet is valid for all products listed on the following pages.



2	Table of contents	
1	Description	1
2	Table of contents	2
3	Ordering data	3
4	Technical data	3
5	Safety notes.....	6
	5.1 Installation in the Ex area (zone 2).....	7
	5.2 Installation in areas with a danger of dust explosions	7
6	Basic circuit diagram	8
7	Derating.....	8
	7.1 Vertical mounting position	8
	7.2 Horizontal mounting position	8
8	Load curve.....	8
9	Operating and indication elements	9
	9.1 Connection versions	9
	9.2 Connection assignment.....	9
10	Mounting and connection	10
11	Startup.....	10
12	Proof test	11
	12.1 Testing of relay channels	11
	12.2 Testing diagnostics	11
13	Calculating the power dissipation	11
14	Application examples	12
	14.1 Application example 1 - SIL 3.....	13
15	Revision history	14

3 Ordering data

Description	Type	Order No.	Pcs./Pkt.
Coupling relay for SIL 3 low demand applications, couples digital output signals to the periphery, 1 enabling current path, module for F&G applications, test pulse filter, plug-in screw connection, 17.5 mm width	PSR-PC50-1NO-1DO-24DC-SC	2904664	1
Coupling relay for SIL 3 low-demand applications, couples digital output signals to the I/O, 1 enabling current path, module for F&G applications, test pulse filter, plug-in spring-cage terminal block, width: 17.5 mm	PSR-PC50-1NO-1DO-24DC-SP	2904665	1

4 Technical data

Hardware/firmware version	
HW/FW	≥ 00/-- (The technical data and safety characteristics are valid as of the specified HW/FW version.)
Input data	
Nominal input voltage U_N	24 V DC -15 %; +10 % (A1/A2 and 24V/A2)
Input voltage range (factor)	0.85 ... 1.1
Typical input current	65 mA (A1/A2) 15 mA (24V/A2; depending on load M1 +100 mA)
Typical inrush current	≤ 200 mA (A1/A2) 2.5 A (24V/A2; for 10 μs) 200 mA (Inputs TP1, TP2 and TP3)
Current consumption	typ. 20 mA (Input TP1) typ. 18 mA (Input TP2) typ. 35 mA (Input TP3)
Max. permissible overall conductor resistance (Input and reset circuit at U_N)	< 10 Ω (LO/LO' and NI/NI' and load resistance in the event of a short circuit)
Typical pick-up time	30 ms (when controlled via A1)
Typical release time	30 ms (when controlled via A1)
Recovery time	1 s
Maximum switching frequency	0.5 Hz
Operating voltage display	Yellow LED
Status display	Green LED
Indication	Red LED
Protective circuit	Overload protection Suppressor diode
Output data	
Contact type	1 enabling current path
Contact material	AgNi, gold-flashed
Minimum switching voltage	15 V AC/DC (without diagnostics) 20 V AC/DC (with diagnostics)
Maximum switching voltage	250 V AC 125 V DC
Limiting continuous current	5 A (N/O contact)
Diagnostic threshold	20 Ω / 18 kΩ (lower/upper)
Maximum inrush current	5 A
Inrush current, minimum	100 mA
Switching capacity min.	1.5 W
Mechanical service life	Approx. 5×10^7 cycles

Alarm outputs		
Number of outputs	1 (digital)	
Voltage	23 V DC	
Current	max. 100 mA	
Short-circuit protection	no	
General data		
Relay type	Electromechanically forcibly guided, dust-proof relay.	
Nominal operating mode	100% operating factor	
Degree of protection	IP20	
Min. degree of protection of inst. location	IP54	
Mounting position	vertical or horizontal	
Mounting type	DIN rail mounting	
Air clearances and creepage distances between the power circuits	DIN EN 50178	
Rated insulation voltage	250 V AC	
Rated surge voltage/insulation	6 kV/safe isolation (through protective impedance)	
Pollution degree	2	
Surge voltage category	III	
Dimensions	Screw connection	Spring-cage connection
W x H x D	17.5 x 112.2 x 114.5 mm	17.5 x 117.4 x 114.5 mm
Connection data	Screw connection	Spring-cage connection
Conductor cross section, solid	0.2 mm ² ... 2.5 mm ²	0.2 mm ² ... 1.5 mm ²
Conductor cross section, stranded	0.2 mm ² ... 2.5 mm ²	0.2 mm ² ... 1.5 mm ²
Conductor cross section AWG/kcmil	24 ... 12	24 ... 16
Stripping length	7 mm	8 mm
Ambient conditions		
Ambient temperature (operation)	-20 °C ... 55 °C	
Ambient temperature (storage/transport)	-40 °C ... 65 °C	
Max. permissible relative humidity (operation)	75 % (on average, 85% infrequently, non-condensing)	
Max. permissible humidity (storage/transport)	75 % (on average, 85% infrequently, non-condensing)	
Maximum altitude	≤ 2000 m (Above sea level)	
Shock	15g	
Vibration (operation)	2g	
Conformance / approvals		
Conformance	CE-compliant	
Approvals		
IECEX (IECEx ULD 14.0003X)	Ex nA nC IIC T4 Gc	
ATEX (DEMKO 14 ATEX 1284X)	 II 3 G Ex nA nC IIC T4 Gc	
UL, USA / Canada (E140324)	cULus	
UL, USA / Canada (E360692)	Class I, Zone 2, AEx nA nC IIC T4 / Ex nA nC IIC Gc T4 X	
Shipbuilding (11253-14 HH)	C, EMC2	
Functional Safety in accordance with IEC 61508	to SIL 3	

Safety parameters for IEC 61508 - Low demand

SIL	3 (15 % of total SIL)
PFD _{avg}	$1,49 \times 10^{-4}$
Proof test interval	120 Months
Duration of use	240 Months

Alternative illustration of the device as 1001 structure for process customers

Calculation basis	Application example 1 - SIL 3
Equipment type	Type A
HFT	0
SIL	3 (15 % of total SIL)
Safe Failure Fraction (SFF)	99.6 %
λ_{SD}	4.27 FIT
λ_{SU}	849 FIT
λ_{DD}	4.21 FIT
λ_{DU}	3.40 FIT
λ_{Total}	860.88 FIT
MTBF	110.5 Years
PFD _{avg}	$1,49 \times 10^{-5}$ (For T1 = 1 year)

5 Safety notes



WARNING: Risk of electric shock

During operation, parts of electrical switching devices carry hazardous voltages.

Before working on the switching device, disconnect the power.

Please observe the safety regulations of electrical engineering and industrial safety and liability associations!

Disregarding these safety regulations may result in death, serious personal injury or damage to equipment.

Startup, mounting, modifications, and upgrades should only be carried out by a skilled electrical engineer!



WARNING: Danger due to faulty devices!

The devices may be damaged following an error and correct operation can no longer be ensured.

In the event of an error, replace the device immediately.

Repairs to the device, especially if the housing must be opened, may only be carried out by the manufacturer or authorized persons. Otherwise the warranty is invalidated.



WARNING: risk of electric shock!

The safety relay may only be connected to devices which meet the requirements of EN 60950.

Suitable devices are available online at phoenixcontact.net/products.



WARNING: Loss of safety function

When an error is detected by the higher-level controller, it is assumed that the safety function can no longer be performed.

The error must be removed within 72 hours or within the process safety time if required by the application.



WARNING: Risk due to incorrect installation

For reliable operation, the safety relay must be installed in housing protected from dust and humidity (IP54).

Carry out wiring according to the application. Refer to the "Application examples" section for this.



NOTE: Risk of damage to equipment due to noise emissions

When operating relay modules the operator must meet the requirements for noise emission for electrical and electronic equipment (EN/ IEC 61000-6-4) on the contact side and, if required, take appropriate measures.



NOTE: Risk of damage to equipment due to noise emissions

This is a Class A product. In a domestic environment it may cause radion interference, in which case the user may be required to take adequate measures.



Only use power supply units with safe isolation and SELV / PELV in accordance with EN 50178/VDE 0160 (SELV / PELV).

5.1 Installation in the Ex area (zone 2)



WARNING: Explosion hazard

The category 3 device is suitable for installation in the zone 2 potentially explosive area. It fulfills the requirements of EN 60079-0:2012+A11:2013 (IEC 60079-0:2011 6th ED.) and EN 60079-15:2010 (IEC 60079-15:2010 4th ED.).



WARNING: Explosion hazard

The device should be installed in a housing (control or distributor box) that fulfills the requirements of EN 60079-15:2010 (IEC 60079-15:2010 4th ED.) and at least IP54 (EN/ IEC 60529) degree of protection.



WARNING: Explosion hazard

The device must be used in no more than a pollution degree 2 environment as defined by EN/ IEC 60664-1.



WARNING: Explosion hazard

When installing and connecting the supply and signal circuits observe the requirements of EN/ IEC 60079-14. Only devices suitable for operation in Ex zone 2 and the conditions at the application site may be connected to the circuits in zone 2.

In potentially explosive areas, only connect and disconnect cables when the power is disconnected.



WARNING: Explosion hazard

The device must be stopped and immediately removed from the Ex area if it is damaged or was subject to an impermissible load or stored incorrectly or if it malfunctions.



Only use category 3G devices (ATEX 94/9/EC).

Ambient temperature in hazardous areas (zone 2)

Observe the derating curves.

Observe the special temperature conditions according to the rating plate.

Relay Output	250 V AC / 24 V DC, 5 A Resistive B300, R300	250 V AC / 24 V DC, 0.5 A
Ambient Temperature	-20 °C to 40 °C	-20 °C to 60 °C

5.2 Installation in areas with a danger of dust explosions



WARNING: Explosion hazard

The device is not designed for use in atmospheres with a danger of dust explosions.

6 Basic circuit diagram

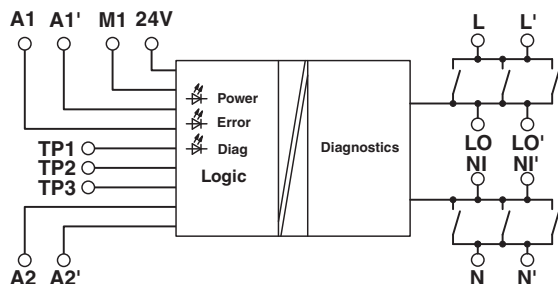

Figure 1 Block diagram

Key:

Designation	Explanation
A1/A2	Safety relay input voltage
A1'/A2'	Safety relay input voltage for optionally redundant wiring
M1	Digital alarm output
24 V	Supply voltage for connectable load monitoring
TP1/TP2/TP3	Test point for proof test
L/L'	On-load voltage input
N/N'	0 V
LO/LO'	Load input
NI/NI'	Load output



Contacts A1', A2', L', N', LO', NI' are **not** suitable for further wiring. These contacts may only be used for optional redundant wiring.

7 Derating

7.1 Vertical mounting position

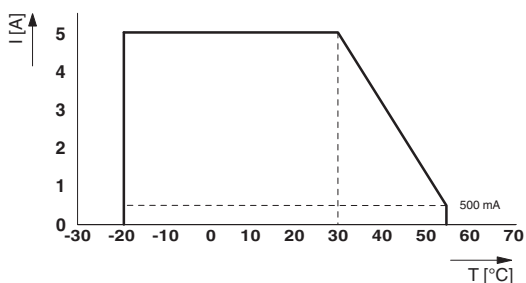

Figure 2 Vertical installation derating curve

7.2 Horizontal mounting position

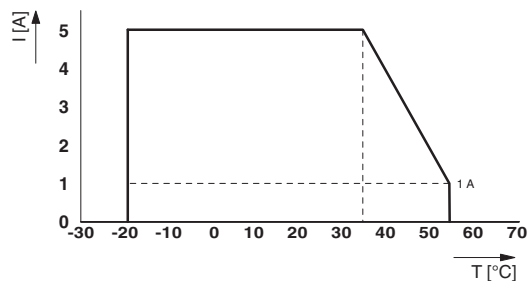

Figure 3 Horizontal installation derating curve

8 Load curve

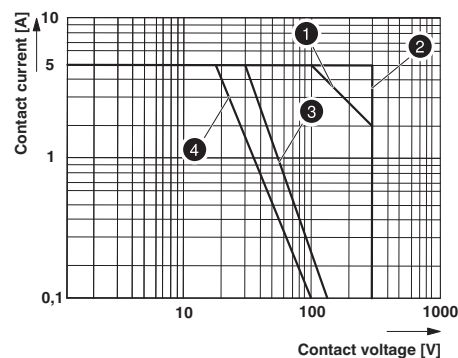

Figure 4 Relay load curve

Key:

No.	Explanation
1	AC inductive load $\cos \varphi = 0.4$
2	AC resistive load
3	DC resistive load
4	DC inductive load $L/R = 7 \text{ ms}$

9 Operating and indication elements

9.1 Connection versions

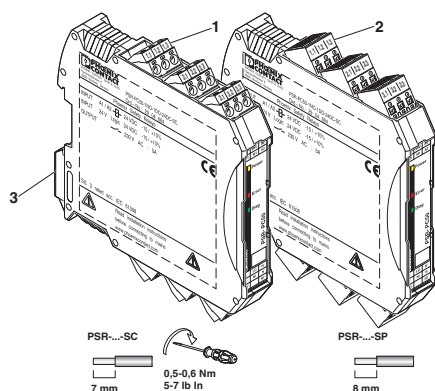

- 1 COMBICON plug-in screw terminal block
- 2 COMBICON plug-in spring-cage terminal block
- 3 Metal lock for fixing to DIN rail

Figure 5 Connection versions

9.2 Connection assignment

Figure	Designation	Explanation
	TP1/TP2/TP3	Test point for proof test
	A1/A2	Safety relay input voltage
	A1'/A2'	Safety relay input voltage for optionally redundant wiring
	24 V	Supply voltage for connectable load monitoring
	M1	Digital alarm output
	Power	LED status indicator, yellow - contacts on the load side are closed
	Error	LED status indicator, red - error
	Diag	LED status indicator, green - diagnostics are active
	L/L'	On-load voltage input
	N/N'	0 V
	LO/LO'	Load input
	NI/NI'	Load output



Contacts A1', A2', L', N', LO', NI' are **not** suitable for further wiring. These contacts may only be used for optional redundant wiring.

10 Mounting and connection

Mount the module on a 35 mm DIN rail according to EN 60715.

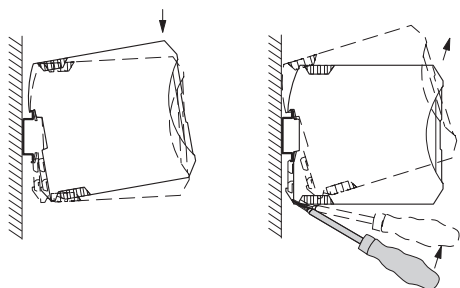

Figure 6 Mounting and removing

Connect the cables to the connection terminal blocks using a screwdriver.

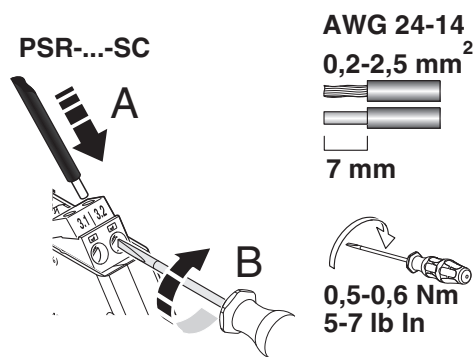

Figure 7 Connecting the cables for PSR-...-SC (screw terminal block)

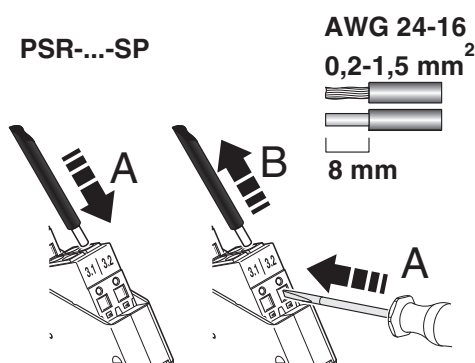

Figure 8 Connecting the cables for PSR-...-SC (spring-cage terminal block)



For compliance with UL approval, use copper wire that is approved up to 60°C/75°C.

11 Startup

Once the nominal input voltage of 24 V DC has been enabled at terminals **A1** and **A2** (as well as **A1'** and **A2'** for optionally redundant wiring), the Power LED lights up.

The contacts **L, L', LO, LO'** as well as **NI, NI'** and **N, N'** close.

The **24 V** connection should only be activated if the diagnostic function is to be used, and should be set to **A2**.

The minimum diagnostic threshold value is **20 Ω**, the maximum value is **18 kΩ**.

Diagnostics is performed for open circuit and short circuit of the load as well as for a loss of on-load voltage, load supply voltage and supply voltage for diagnostics.

The activation of diagnostic functions is indicated by the **Diag LED**.

If the diagnostics respond, the minimum current consumption is pushed and a **bad channel** is generated via **A1** (depending on the controller).

Additionally the **Error LED** illuminates and the semiconductor alarm output **M1** is active.

The load is not monitored when the contacts are closed on the output side.

The diagnostic function is not suitable for semiconductor loads.

- Perform a full function and diagnostic test during start-up.

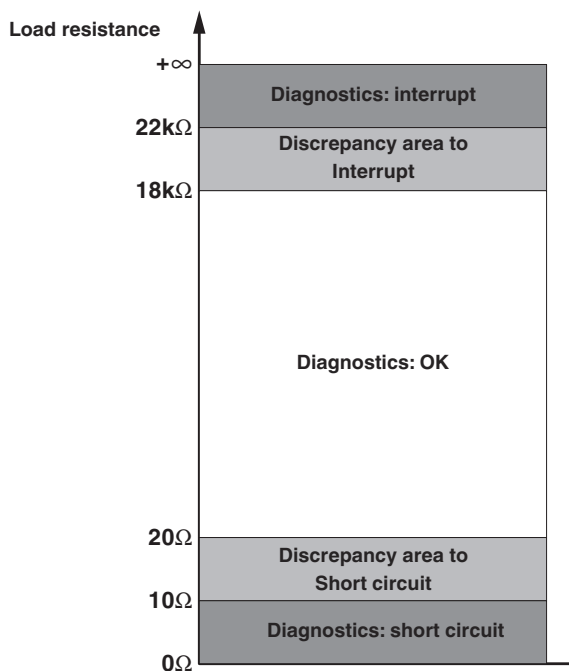

Figure 9 Diagnostic thresholds

12 Proof test

The Proof test checks the individual relay channels and device diagnostics to ensure proper functioning.



CAUTION: The enabling contacts are closed during the Proof test!

12.1 Testing of relay channels

1. Disconnection of A1/A1'
2. Apply 24 V DC to TP1 (set to A2/A2'). Check whether the load is activated/whether the contacts L to LO to N to NI have continuity. Then disconnect TP1 again.
3. Repeat step 2 for TP2 and TP3
4. Restore the original configuration so that the reference configuration and the physical configuration are the same again.
5. Check switchability by the controller!



CAUTION: If during step 2 or 3 the load is not activated or no continuity can be measured, the device is faulty. Replace the device!

12.2 Testing diagnostics

1. Interrupt the load path then close it again.
2. Interrupt the load path briefly then restore this to the operating state.
3. Interrupt the supply voltage of the load before connection L or after connection N. Then restore the supply voltage.



CAUTION: If during this diagnostics test no error (ERROR) is displayed, the device is faulty. Replace the device!

13 Calculating the power dissipation



The total power dissipation of the safety relay is based on the input power dissipation and the contact power dissipation for the same and for different load currents.

Input power dissipation

$$P_{\text{Input}} = U_B^2 / (U_S / I_S)$$

Contact power dissipation

With the same load currents:

$$P_{\text{Contact}} = n \cdot I_L^2 \cdot 50 \text{ m}\Omega$$

With different load currents:

$$P_{\text{Contact}} = (I_{L1}^2 + I_{L2}^2 + \dots + I_{Ln}^2) \cdot 50 \text{ m}\Omega$$

Total power dissipation

$$P_{\text{Total}} = P_{\text{Input}} + P_{\text{Contact}}$$

therefore

$$P_{\text{Total}} = U_B^2 / (U_S / I_S) + n \cdot I_L^2 \cdot 50 \text{ m}\Omega$$

or

$$P_{\text{Total}} = U_B^2 / (U_S / I_S) + (I_{L1}^2 + I_{L2}^2 + \dots + I_{Ln}^2) \cdot 50 \text{ m}\Omega$$

Key:

Designation	Explanation
P	Power dissipation in mW
U_B	Applied operating voltage
U_S	Rated control supply voltage
I_S	Rated control supply current
n	Number of enabling current paths used
I_L	Contact load current

14 Application examples

Key:

- SIS = Safety Instrumented System (safe control)
- DC = Diagnostic Coverage according to IEC 61508
(line/load diagnostics at DO)
- DI = Digital input
- DO = Digital output

Connection options:

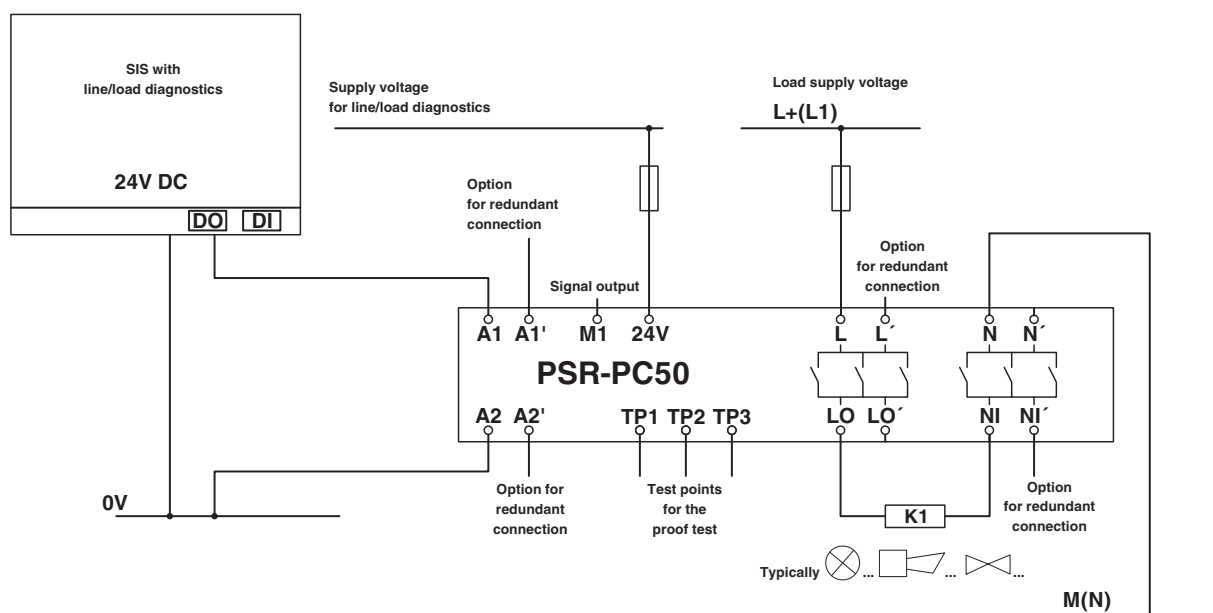

Figure 10 Connection options

14.1 Application example 1 - SIL 3

Assumptions, information, and marginal conditions

- The DC of the digital output is 90%.
- Diagnostics of PSR-PC50 are active.
- The test pulses of the controller are activated and evaluated.
- A potential error is indicated accordingly.



A fault e.g., open circuit or short circuit of the load is reported by detuning the test pulse of the safe controller.

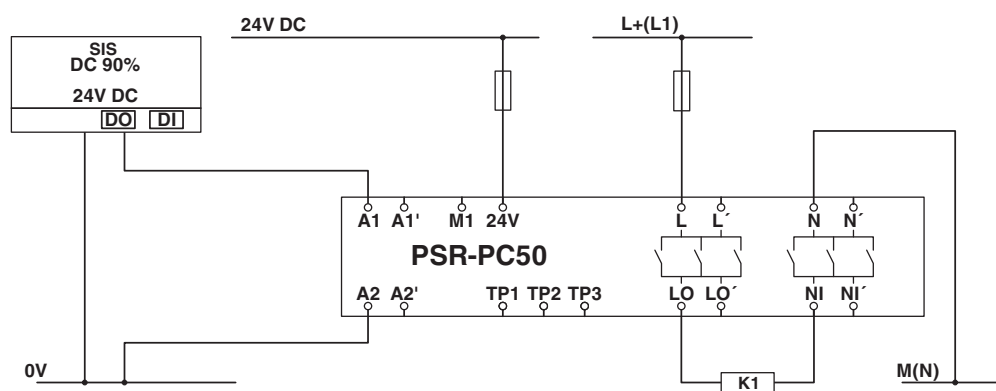

Figure 11 Application example 1 - SIL 3

15 Revision history

Version	Date	Contents
00	2014-05-23	First publication
01	2014-08-14	Data added regarding the compatible controllers; technical data updated; notes on contacts A1', A2', L', N', LO', NI' added; figure on diagnostic thresholds added; general conditions for application example extended
02	2014-04-08	HW/FW status added; safety notes revised; section added: mounting and connection, calculation of power dissipation, revision history; data added according to Ex approval



SCATTERGOOD & JOHNSON LTD

ELECTRICAL ENGINEERING & FLUID CONTROL DISTRIBUTORS

Est.1899

At Scattergood & Johnson Ltd, we pride ourselves on being a technical distributor to specialist industries.

Working with a range of quality product suppliers across a number of specialist markets, we are not your average 'box shifter' - we are your technical and supply chain partner.

We fully support every product we sell - for free! Our internal team and external sales engineers can answer any product or application question, no matter the complexity.

Backing up this technical ability is a range of 50,000+ products available from stock for nationwide next day delivery (same day if required!), or you can collect what you need from any of our trade counters around the UK.

Select your specialist interest below to learn more about how we can help.



Online, In Branch and On the Road - Scattergood & Johnson Ltd, there when you need us.

www.scatts.co.uk